

DIRECT POWER

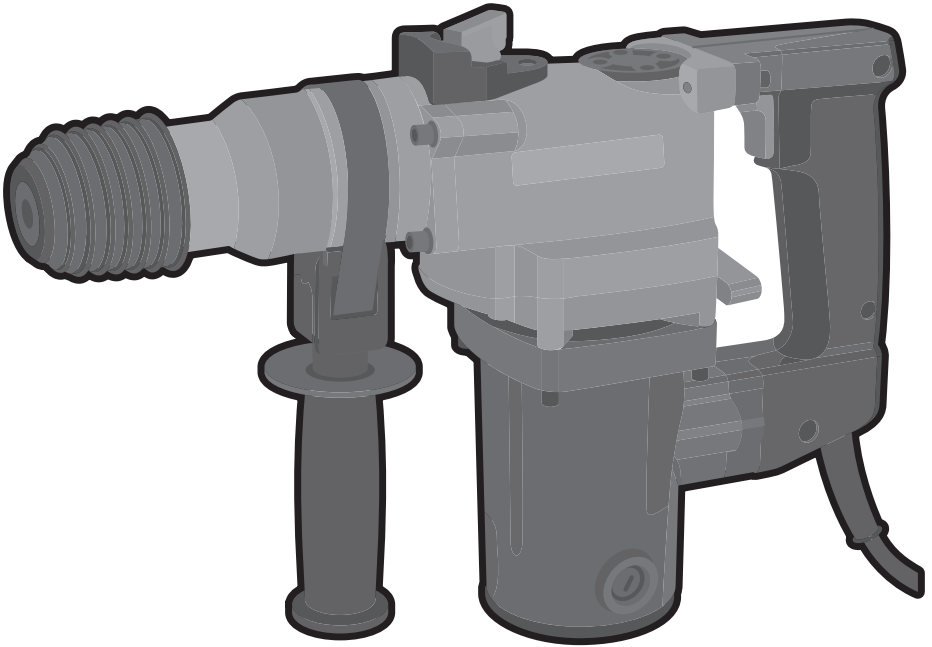

12 month
Full Manufacturer's
Warranty

SAFETY AND OPERATING MANUAL

5kg SDS Plus Rotary Hammer Drill BH26S3

DIRECTPOWER

Congratulations on your purchase of a DIRECTPOWER power tool from Screwfix Direct Ltd. We want you to continue getting the best performance from it so this handbook includes information on safety, handling and care. Please retain this handbook in case you need to refer to any of the information in the future.

Your DIRECTPOWER power tool comes with a 12-month guarantee,so should it develop a fault within this period contact Screwfix Direct Ltd on Freephone 0500 41 41 41.

GUARANTEE

This DIRECTPOWER product carries a Screwfix Direct Ltd guarantee of 12 months. If your product develops a fault within this period, you should,in the first instance contact Screwfix Direct Ltd on Freephone 0500 41 41 41. If the fault occurs within the first 12 months, you may return the goods for a full refund or we will repair or replace the goods if you prefer. When repair is not practical or identical goods are not available, alternative goods of similar specification and quality will usually be provided but, failing this, you will be offered a partial or full refund depending on the time period since purchase.

This guarantee specifically excludes losses caused due to:

- Fair wear and tear
- Misuse or abuse
- Lack of routine maintenance
- Failure of consumable items (such as batteries)
- Accidental damage
- Cosmetic damage
- Failure to follow manufacturer's guidelines
- Loss of use of the goods
- Repairs attempted by anyone, unless authorised by Screwfix Direct Ltd.

This guarantee does not affect your statutory rights.This guarantee is only valid in the UK.

For further technical advice, spare parts or repair service (outside of guarantee) please contact the customer helpline number on 0845 607 6380.

SAFETY INSTRUCTIONS



WARNING! Read all instructions. Failure to follow all instructions listed below may result in electric shock, fire and/or serious injury.

SAVE THESE INSTRUCTIONS

1. Work area.

a. Keep work area clean and well lit. Cluttered and dark areas invite accidents.

b. Do not operate power tools in explosive atmospheres, such as in the presence of flammable liquids, gases or dust. Power tools create sparks which may ignite the dust or fumes.

c. Keep children and bystanders away while operating a power tool. Distractions can cause you to lose control.

2. Electrical safety.

a. Power tool plugs must match the outlet. Never modify the plug in any way. Do not use any adapter plugs with earthed (grounded) power tools. Unmodified plugs and matching outlets will reduce risk of electric shock.

b. Avoid body contact with earthed or grounded surfaces such as pipes, radiators, ranges and refrigerators. There is an increased risk of electric shock if your body is earthed or grounded.

c. Do not expose power tools to rain or wet conditions. Water entering a power tool will increase the risk of electric shock.

d. Do not abuse the cord. Never use the cord for carrying, pulling or unplugging the power tool. Keep cord away from heat, oil, sharp edges or moving parts. Damaged or entangled cords increase the risk of electric shock.

e. When operating a power tool outdoors, use an extension cord suitable for outdoor use. Use of a cord suitable for outdoor use reduces the risk of electric shock.

f. Use a Residual Circuit Breaker on all 230V Power tools. This can help minimise the risk of an electrical shock if an earth fault or short circuits occurs.

g. If using a power cable extension ensure that the cable is fully unwound and that its length is less than 30m. Lengths over 30 m will effect the tools performance as a result of voltage drop.

3. Personal safety.

a. Stay alert, watch what you are doing and use common sense when operating a power tool. Do not use a power tool while you are tired or under the influence of drugs, alcohol or medication. A moment of inattention while operating power tools may result in serious personal injury.

b. Use safety equipment. Always wear eye protection. Safety equipment such as dust mask, non-skid safety shoes, hard hat, or hearing protection used for appropriate conditions will reduce personal injuries.

c. Avoid accidental starting. Ensure the switch is in the off-position before plugging in. Carrying power tools with your finger on the switch or plugging in power tools that have the switch on invites accidents.

d. Remove any adjusting key or wrench before turning the power tool

on. A wrench or a key left attached to a rotating part of the power tool may result in personal injury.

e. Do not overreach. Keep proper footing and balance at all times. This enables better control of the power tool in unexpected situations.

f. Dress properly. Do not wear loose clothing or jewellery. Keep your hair, clothing and gloves away from moving parts. Loose clothes, jewellery or long hair can be caught in moving parts.

g. If devices are provided for the connection of dust extraction and collection facilities, ensure these are connected and properly used. Use of these devices can reduce dust-related hazards.

4. Power tool use and care.

a. Do not force the power tool. Use the correct power tool for your application. The correct power tool will do the job better and safer at the rate for which it was designed.

b. Do not use the power tool if the switch does not turn it on and off. Any power tool that cannot be controlled with the switch is dangerous and must be repaired.

c. Disconnect the plug from the power source before making any adjustments, changing accessories, or storing power tools. Such preventive safety measures reduce the risk of starting the power tool accidentally.

d. Store idle power tools out of the reach of children and do not allow persons unfamiliar with the power tool or these instructions to operate the power tool. Power tools are dangerous in the hands of untrained users.

e. Maintain power tools. Check for misalignment or binding of moving parts, breakage of parts and any other condition that may affect the power tools operation. If damaged, have the power tool repaired before use. Poorly maintained power tools cause many accidents.

f. Keep cutting tools sharp and clean. Properly maintained cutting tools with sharp cutting edges are less likely to bind and are easier to control.

g. Use the power tool, accessories and tool bits etc., in accordance with these instructions and in the manner intended for the particular type of power tool, taking into account the working conditions and the work to be performed. Use of the power tool for operations different from intended could result in a hazardous situation.

5. Service.

a. Have your power tool serviced by a qualified repair person using only identical replacement parts. This will ensure that the safety of the power tool is maintained.

HEALTH ADVICE



WARNING! When drilling, sanding, sawing or grinding, dust particles will be produced. In some instances, depending on the materials you are working with, this dust can be particularly harmful to you (e.g. lead from old gloss paint).

You are advised to consider the risks associated with the materials you are working with and to reduce the risk of exposure. You should:

- Work in a well-ventilated area.

-Work with approved safety equipment, such as those dust masks that are specially designed to filter microscopic particles.

ADDITIONAL SAFETY RULES FOR YOUR HAMMER DRILL

This is a powerful hammer drill. Caution needs to be observed when operating.

- 1.If the supply cord is damaged have it replaced by a qualified person.
- 2.Always wear a dust mask.
- 3.Dress in suitable overalls.
- 4.Safety boots are recommended at all times especially when using the chisel action.
- 5.Proper safety gloves are also recommended.
- 6.When using chisel a dust mask is necessary because of the dust created by the action.
- 7.Wear ear protectors. Exposure to noise can cause hearing loss.
- 8.This heavy duty high torque machine should not be used, while standing on a ladder.
- 9.Watch out for the initial torque reaction of the drill, especially when drill bit is tight.
- 10.Do not use damaged or worn drills.
- 11.Do not run the machine with any part of the casing missing or damaged.
- 12.Check walls for hidden electric cable, gas and electric pipe before you start any drilling task.
- 13.Chisel bits and drill bits may be flung out of the machine accidentally and cause serious injury.
- 14.Before starting to work, always check that the chisel or drill bit is properly locked in the chuck.
- 15.Vibrations can injure the hand-arm system. Keep exposure to vibrations as short as possible.
- 16.When carrying out work, always hold the drill with both hands and ensure that you have a stable standing position.
17. Lubricating the gear box.The gear box must be lubricated after approximately 5 hours of use to ensure it works efficiently.A small container of grease is supplied with the drill.Go to section "Maintenance" for the details.
18. Always use the appropriate safety equipment that is required for the product. e.g. Goggles / Safety Spectacles, Ear defenders (essential with tools with a noise rating of over 85 dbA), Gloves and face masks. In all cases ensure that the safety equipment is in good condition.
19. Ensure that if a side handle or stabilising handle is provided with the power tool then these are adjusted into a comfortable position and that both handles are used to securely grip the power tool when in use.

Double insulation:

The tool is double insulated. This means that all the external metal parts are electrically insulated from the mains power supply. This is done by placing insulation barriers between the electrical and mechanical components making it unnecessary for the tool to be earthed.

5kg SDS Plus Rotary Hammer Drill BH26S3

Important note:

Remove the main plug from socket before carrying out any adjustment or servicing.
Ensure your mains supply voltage is the same as your tool rating plate voltage.



Always wear eye protection with this tool.



Always wear ear protection with this tool.



Always wear dust mask protection with this tool.

SYMBOLS



Read the manual



Warning



Wear gloves



Wear dust mask, eye & ear protection

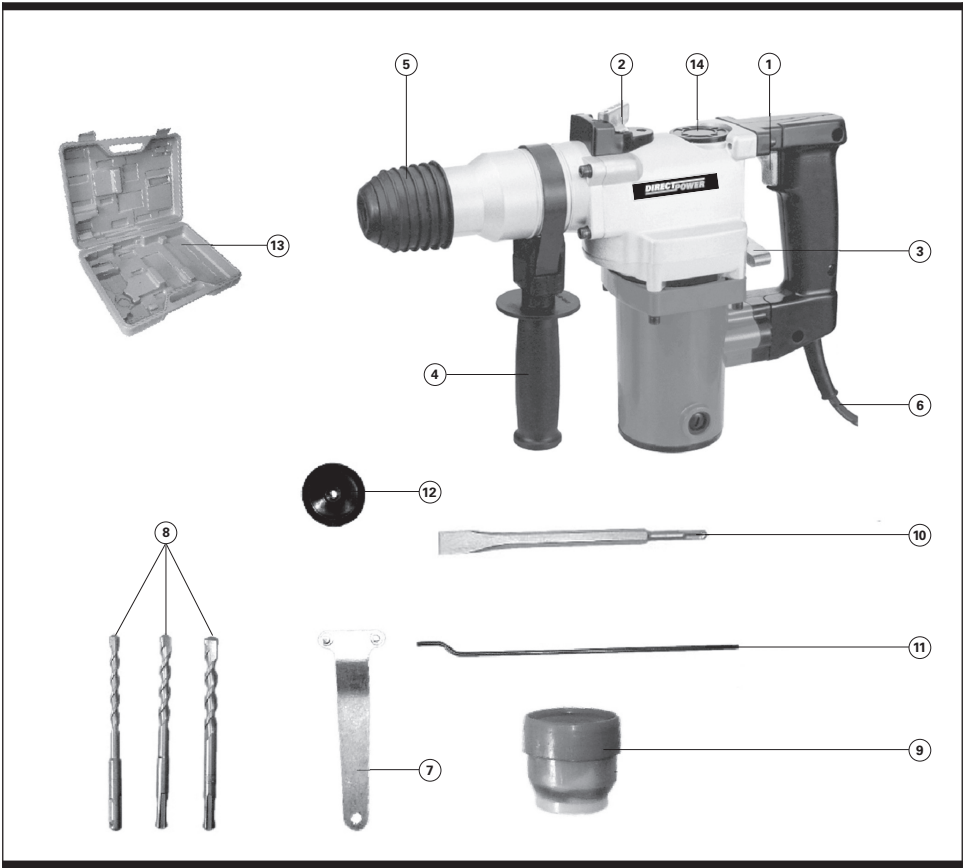

1. ON/OFF SWITCH

2. FUNCTION DIAL SELECTOR LOCK

3. FUNCTION SELECTOR

4. AUXILIARY HANDLE

5. FASTENING SLEEVE

6. MAINS POWER CABLE

7. GEAR BOX COVER SPANNER

8. SDS MASONRY DRILL BITS (8, 10, 12MM)

9. GREASE TUBE

10. CHISEL BIT

5kg SDS Plus Rotary Hammer Drill BH26S3

11. DEPTH GAUGE

12. DUST COVER

13. BLOW MOULD CASE

14. GEAR BOX COVER

TECHNICAL DATA

Voltage:	230V~50Hz
Wattage:	850W
No load speed:	750min ⁻¹
Hammer rate:	3150min ⁻¹
Double insulation:	<input type="checkbox"/>
Weight:	4.8kg

NOISE AND VIBRATION DATA

Sound pressure level:	92.7dB (A)
Sound power level:	105.7dB (A)
Vibration level:	6.795m/s ²

ACCESSORIES

Gear box cover spanner:	1pc
SDS drill bits:	3pcs
Grease tube:	1pc
Flat chisel bit:	1pc
Depth gauge:	1pc
Dust cover:	1pc
Auxiliary handle:	1pc

OPERATION INSTRUCTIONS

1. GENERAL DESCRIPTION

This ROTARY HAMMER DRILL can be used for drilling masonry, contained in the case is a selection of larger masonry bits and chisels. These fit directly into the rotary hammer. Using the hammer setting the supplied chisels can be used to break brick work. The machine uses a single phase alternating current 230V, 50Hz motor, its compact and robust format makes it versatile and efficient for uses described in specific safety instructions. It complies to current regulations and the optimum quality of materials used will ensure a long working life in complete safety.

2. OPERATING INSTRUCTION

Familiarize yourself with the rotary hammer drill before use.

Note: Make sure the hammer is isolated from the mains supply before fitting accessories. Before undertaking any maintenance or operations on the rotary hammer detach the plug from the mains socket.

3. FITTING THE AUXILIARY HANDLE

Attached the handle as shown in Fig 2 depending on being left handed or right handed.

4. FITTING SDS TOOLS

The drill is equipped with an SDS-plus attachment system. The SDS tools have slots in the shank. These locate with tabs in the rotary hammer. Hold the rotary hammer with one hand facing away from yourself. See Fig 3.

Grip and pull back the fastening sleeve and insert the SDS tool.

Push inwards until a resistance is felt. It may be necessary to spin the SDS tool until the shaft drops completely into place.

Once you are satisfied it has seated release the black fastening sleeve. This should lock the SDS tool into position.

5. REMOVE SDS TOOL

Pull back fastening sleeve, hold and remove tool. See Fig 3.

Note: The SDS tools will be gripped firmly by its shank and will not be able to be removed.

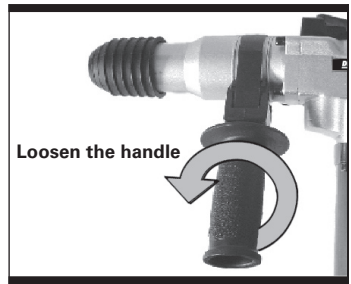

Fig 2

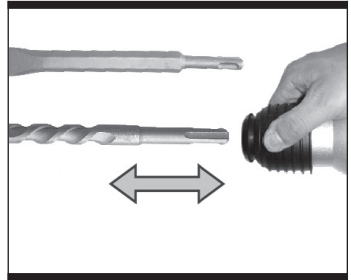

Fig 3

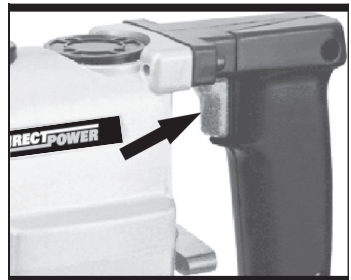

Fig 4



Fig 5

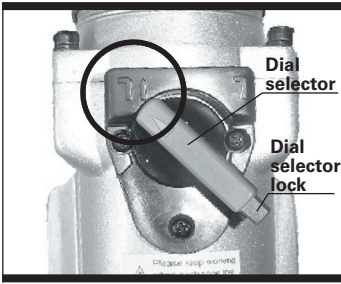

Fig 6



Fig 7

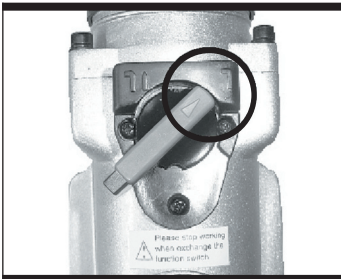

Fig 8



Fig 9

See Fig 3. If the SDS tool is not located repeat the installation operation again.

6. OPERATING THE ON/OFF SWITCH

Holding the Rotary Hammer with both hands and press the single speed on/off switch in for operation (see Fig 4), release switch to stop.



WARNING! If the hammer/drill selector can not go into position, turn the gearbox. Before operating, select required mode by aligning symbol on switch with arrow. And ensure selector is positioned. It could cause a hazard if the selector switch is not firmly locked.

Note: Press the dial selector lock before adjusting the dial selector anytime.

7. HAMMER DRILL FUNCTION

- 1 Adjust the lever selector to position "T" to provide the hammer action (see Fig 5)
- 2 Adjust the dial selector to position "T" to provide rotation of the chuck (see Fig 6)
- 3 you are now set up for drilling into masonry.

8. CHISEL FUNCTION

- 1 Adjust the lever selector to position "T" to provide the hammer action (see Fig 7)
- 2 Adjust the dial selector to position "T" to stop rotation of the chuck (see Fig 8)
- 3 you are now set up for chisel work using hammer action.

To fit a chisel bit, see **FITTING SDS TOOLS OR CHUCK** on page 9. The chisel will be gripped firmly by its shank.

9. DRILLING FUNCTION

- 1 Adjust the lever selector to position "T" to stop the hammer action (see Fig 9)
- 2 Adjust the dial selector to position "T" to provide rotation of the chuck (see Fig 10)
- 3 you are now set up for chisel work using hammer action.

10. USING THE DEPTH GAUGE:

1. Rotate the handle anti-clockwise, insert depth gauge into the handle (see Fig 11).
2. Adjust the depth gauge to desired depth.

3. Rotate the handle clockwise to tighten the depth gauge.

11. SAFETY WHEN USING THE ROTARY HAMMER

This is a powerful tool. Caution needs to be observed when operating. Dress in suitable overalls. Safety boots are recommended at all times especially when using the chisel actions. Proper safety gloves are also recommended. When using chisel mode, a dust mask is necessary because of the cement dust created by the action.

NOTE: DO NOT USE THE DRILL WHEN STANDING ON A LADDER.



CAUTION! Care should be taken if asbestos is suspected of being drilled or chiseled. This is highly dangerous to the user and people in the vicinity and professional help should be sought for its removal and disposal.

12. GEARBOX MAINTENANCE

Always check there is sufficient grease in the grease box before usage. Check every 5 hrs of usage. Open the grease box lid at the top of the drill using the pin spanner provided. Then top up the grease box (capacity 20gms max) using the grease provided with your tool. The grease specification is general purpose lithium based. Use the end open spanner open the Gearbox oil cap. See Fig 12.

13. CHANGING THE CARBON BRUSHES

When the carbon brushes need replacing call the help line.

14. CHISEL AND DRILL BITS

Inspect regularly chisel and drill bits for damage and sharpness. If in doubt obtain new chisels and bits from a qualified dealer.

MAINTENANCE

1. Your power tool requires no additional lubrication or maintenance.



Fig 10

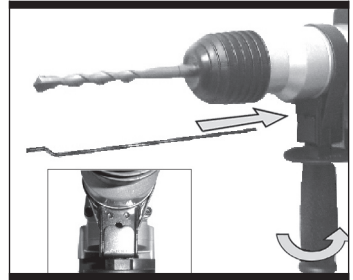

Fig 11

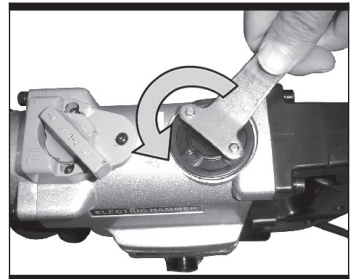

Fig 12

2. Never use water or chemical cleaners to clean your power tool. Wipe clean with a dry cloth.
3. Always store your power tool in a dry place.
4. Keep the motor ventilation slots clean.
5. If you see some sparks flashing in the ventilation slots, this is normal and will not damage your power tool.
6. If the supply cord becomes damaged etc.

HANDY HINTS

Always use sharp good quality drill bits and chisels. The performance of the drill is dependent on the quality of the bits used.

- Reduce the pressure on the drill bit when it is about to break through. This will prevent the drill from jamming.
- When drilling a large hole, first drill a pilot hole using a smaller drill bit.
- Always apply pressure to your drill bit in a straight line, and if possible at right angles to the workpiece.
- When drilling holes into walls, floors etc., always make sure that there are no live electrical wires, or pipe work in the path of the bit.
- Always operate your drill using both the handle and the front handle.
- Never change the operating mode whilst the drill is running.
- When using the product in the hammer only mode, or when chiseling masonry, make sure that you wear safety glasses and protective gloves.
- Do not apply excessive pressure to the tool when chiseling. Excessive force does not speed up the work.

ENVIRONMENTAL PROTECTION



Waste electrical products should not be disposed of with household waste. Please  recycle where facilities exist. Check with your Local Authority or retailer for recycling advice.

PLUG REPLACEMENT

The fuse in the main plug of your power tool should always be replaced with one of identical rating.

Check the voltage given on your power tool matches the supply voltage.

The power tool is supplied with a fitted plug, however if you should need to fit a new plug follows the instruction below.

IMPORTANT

The wire in the mains lead are coloured in accordance with the following code:

Blue ---Neutral

Brown ---Live

The wire that is coloured **blue** must be connected to the terminal that is marked with the letter **N**. The wire that is coloured **brown** must be connected to the terminal that is marked with the letter **L**.

A 13AMP (BS1363 or BS1363/A) plug must be used and a 13 AMP fuse must be fitted.

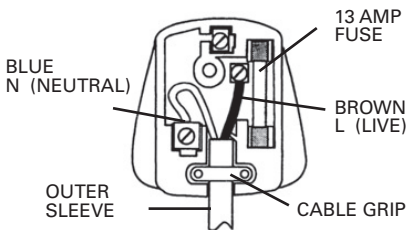



Declaration of Conformity

We, Importer

Screwfix Direct Ltd

Mead Avenue

Houndstone Business Park

Yeovil

BA 22 8RT

Declare that the product

ROTARY HAMMER

BH26S3

Complies with the essential health and safety requirements of the following directives:

89/336 EEC, 93/68 EEC. –EMC Directive.

73/23 EEC, 93/68 EEC. –Low Voltage Directive

98/37 EC. –Machinery Directive.

Standards and technical specifications referred to:

EN 60745-1:2003/A1:2003

EN 60745-2-6:2003

EN 55014-1/A2:2002

EN 55014-2/A1:2001

EN 61000-3-2:2000

EN 61000-3-3/A1:2001

Authorised Signatory

Date: 03/15/05

Signature: _____

Name: Peter Harries
Screwfix Direct Ltd
Quality Manager



2005

5kg SDS Plus Rotary Hammer Drill BH26S3

***DIRECT* POWER**