

TITAN®



12 month
Full
Manufacturer's
Warranty

SAFETY AND OPERATING MANUAL

5 SPEED BENCH PILLAR DRILL SF13N

TITAN®

Congratulations on your purchase of a TITAN power tool from Screwfix Direct Ltd. We want you to continue getting the best performance from it so this handbook includes information on safety, handling and care. Please retain this handbook in case you need to refer to any of the information in the future.

Your TITAN power tool comes with a 12-month guarantee, so should it develop a fault within this period contact Screwfix Direct Ltd on Freephone 0500 41 41 41.

GUARANTEE

This **TITAN** product carries a Screwfix Direct Ltd guarantee of 12 months. If your product develops a fault within this period, you should, in the first instance contact Screwfix Direct Ltd on Freephone 0500 41 41 41. If the fault occurs within the first 12 months, you may return the goods for a full refund or we will repair or replace the goods if you prefer. When repair is not practical or identical goods are not available, alternative goods of similar specification and quality will usually be provided but, failing this, you will be offered a partial or full refund depending on the time period since purchase.

This guarantee specifically excludes losses caused due to:

- Fair wear and tear
- Misuse or abuse
- Lack of routine maintenance
- Failure of consumable items (such as batteries)
- Accidental damage
- Cosmetic damage
- Failure to follow manufacturer's guidelines
- Loss of use of the goods
- Repairs attempted by anyone, unless authorized by Screwfix Direct Ltd.

This guarantee does not affect your statutory rights. This guarantee is only valid in the UK.

For further technical advice, spare parts or repair service (outside of guarantee) please contact the customer helpline number on 0845 607 6380.

SAFETY INSTRUCTIONS



WARNING! Read all instructions. Failure to follow all instructions listed below may result in electric shock, fire and/or serious injury.

SAVE THESE INSTRUCTIONS

1. Keep the work area clean.

Cluttered areas and benches invite injuries.

2. Consider work area environment.

Do not expose power tools to rain. Do not use power tools in damp or wet locations. Keep the work area well lit. Do not use tools in the presence of flammable liquids or gases.

3. Guard against electric shock.

Avoid body contact with earthed or grounded surfaces (e.g. pipes, radiators, ranges, refrigerators).

4. Keep persons away.

Do not let persons, especially children, not involved in the work touch the tool or the extension cord and keep them away from the work area.

5. Store idle tools.

When not in use, tools should be stored in a dry, locked up place, out of reach of children.

6. Do not force the tool.

It will do the job better and safer at the rate for which it was intended.

7. Use the right tool.

Do not force small tools to do the job of a heavy-duty tool. Do not use tools for purposes not intended, for example, do not use circular saws to cut tree limbs or logs.

8. Dress properly.

Do not wear loose clothing or jewellery, they can be caught in moving parts. Non-skid footwear are recommended when working outdoors. Wear protective hair covering to contain long hair.

9. Use protective equipment.

Use safety glasses. Use face or dust mask if working operations create dust.

10. Connect dust extraction equipment.

If the tool is provided for the connection of dust extraction and collecting equipment, ensure these are connected and properly used.

11. Do not abuse the cord.

Never yank the tool to disconnect it from the socket. Keep the cord away from heat, oil and sharp edges.

12. Secure work.

Where possible use clamps or a vice to hold the work. It is safer than using your hand.

13. Do not overreach.

Keep proper footing and balance at all times.

14. Maintain tool with care.

Keep cutting tools sharp and clean for better and safer performance. Follow instructions for lubrication and changing accessories. Inspect tool cord periodically and if damaged have them replaced by an authorised service facility. Inspect extension cords periodically and replace if damaged. Keep handles dry, clean and free of oil or grease.

15. Disconnect tools.

When not in use, before servicing and when changing accessories such as blades, bits and cutters, disconnect tools from the power supply.

16. Remove adjusting keys and wrenches.

From the habit of checking to see that keys and adjusting wrenches are removed from the tool before turning it on.

17. Avoid unintentional starting.

Ensure switch is in the "off" when plugging in.

18. Use outdoor extension leads.

When tool is used outdoors, use only extension cords intended for outdoor use and so marked.

19. Stay alert.

Watch what you are doing. Use common sense. And do not operate tool when you are tired.

20. Check damaged parts.

Before further use of the tool, it should be carefully checked to determine that it will operate properly and perform its intended function. Check for alignment of moving parts, binding of moving parts, breakage of parts, mounting and any other conditions that may affect its operation. A guard or other part that is damaged should be properly repaired or replaced by an authorised service centre unless otherwise indicated in this instruction manual. Have defective switches replaced by an authorised service centre. Do not use the tool if the switch does not turn it on and off.

21. Warning.

The using of any accessory or attachment other than those recommended in this instruction manual may present a risk of personal injury.

22. Have your tools repaired by qualified person.

This electrical tool complies with the relevant safety rules. Repairs should only be carried out by qualified persons using original spare parts, otherwise this may result in considerable danger to the user.

HEALTH ADVICE



WARNING! When drilling, sanding, sawing or grinding, dust particles will be produced. In some instances, depending on the materials you are working with, this dust can be particularly harmful to you (e.g. lead from old gloss paint).

You are advised to consider the risks associated with the materials you are working with and to reduce the risk of exposure. You should:

-- Work in a well-ventilated area.

-- Work with approved safety equipment, such as those dust masks that are specially designed to filter microscopic particles.

ADDITIONAL SAFETY INSTRUCTIONS FOR YOUR BENCH PILLAR DRILL

1. Only use lubricating oil on drill bits and not near to motor or electrical components. Never spray as a cooling agent. A fatal electric shock could occur.

2. Always use sharp drill bits.

3. Never use sub-standard or blunt drill bits.

4. Never use excessive force on drill handle.
5. Always secure the workpiece to be drilled.
6. Always ensure the machine is securely mounted to a solid workbench.
7. Never remove the guard.
8. Always wear suitable gloves when handling swarf.
9. Wear suitable clothing. Adjust all loose clothing and remove ties, neck chains rings and watches.
10. Tie long hair back or preferably wear a hair net.
11. Use correct speed for size of drill (see speed chart).
12. Care should be taken when drilling brass and copper as drill may jam and break if too much pressure is applied.

SYMBOLS



Read the manual



Warning



Wear gloves



Wear dust mask, eye & ear protection



Conforms to relevant safety standards

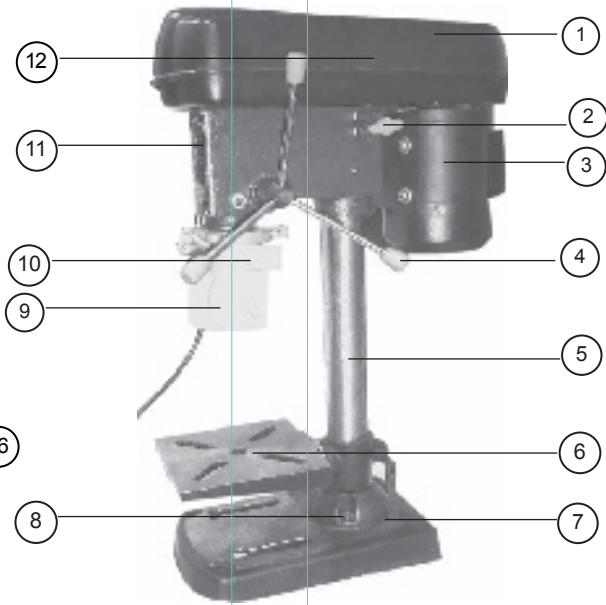
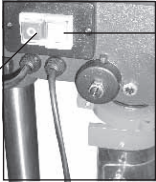
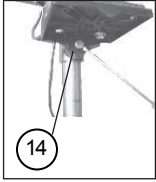
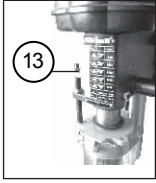

1. PULLEY COVER

2.TENSION ADJUSTOR SCREW

3. MOTOR ASSEMBLY

4. FEED HANDLE

5. SUPPORT COLUMN

6. ADJUSTABLE TILTING TABLE

7. BASE PLATE

8. BOLTS AND WASHERS

9.ADJUSTABLE GUARD

10.GUARD SECURING SCREWS

11. LOCKING NUT

5 SPEED BENCH PILLAR DRILL SF13N

12. PULLEY COVER LOCK SCREW

13. BOLT

14. DEPTH STOP LOCKING NUTS, POINTER AND SCALE

15. OFF SWITCH

16. ON SWITCH

TECHNICAL DATA

Voltage:	230V~50Hz
Power input :	350W (S2:15min)
No load speed:	580-2650min ⁻¹
Drilling depth:	50mm
Table size:	160x160mm
Chuck capacity:	Ø1.5-Ø13mm
Drilling capacity:	Ø13mm
Height:	580mm
Machine weight :	18.0kg

NOISE AND VIBRATION DATA

Sound pressure level:	61.5dB (A)
Sound power level:	74.5dB (A)
Vibration level:	1.6m/s ²

ACCESSORIES

Chuck key

Hexagon wrench

Bolt&washer

1pc

3pcs

1set

OPERATION INSTRUCTIONS



Warning: Before using your drill press, read the instruction manual carefully.

Assembly

Before the drill is started for the first time, it must be solidly and fully mounted on the work area of a stable workbench. Select suitable length bolts, washers and nuts (not supplied). Use four mounting holes in the base plate to do this. Ensure that the machine is freely accessible for operation, adjustment and maintenance.

Note: The fixing screws may only be tightened to a point where they do not distort or deform the base plate. Excessive tension can lead to fracture.

Take the protective paper off the column. Align with the three Threaded holes on the base plate (See Fig 2).

Secure with the three hex bolt sets supplied. Again do not use excessive torque. Slide the adjustable height worktable over the column. Secure midway with the clamping lever. (See Fig 3).

Unscrew the column locating hex keyed grub screws. Lower the headstock and motor assembly all the way onto the column (See Fig 4).

Position the headstock and motor assembly so the front align with the center of the base plate. Secure the two hex-keyed grub screws with the supplied key.

Retain for further adjustments.

Unscrew the guard securing screws.

Locate the telescopic guard and locate into the spring loaded guard holder.

Secure with small cross-headed screws. Attach the three handles into the feed shaft. (See Fig5)

Raise the adjustable work table and place on it a piece of scrap wood or paper.

Locate the chuck and lower the drive spindle. Put on the chuck.(See Fig 6)

Note: It has a tapered shaft and the chuck locates onto this. Bring the chuck into contact with the wood on the work table and gently apply pressure to lock the chuck onto the spindle.

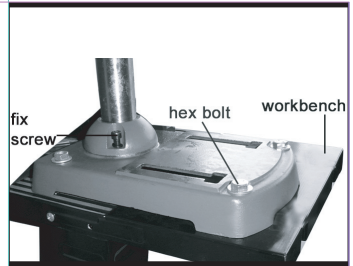

Fig 2

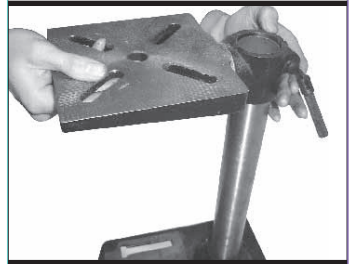

Fig 3

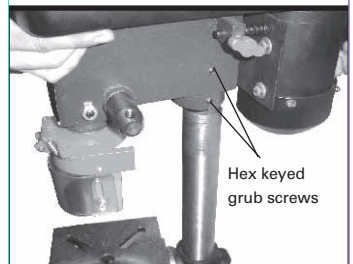

Fig 4

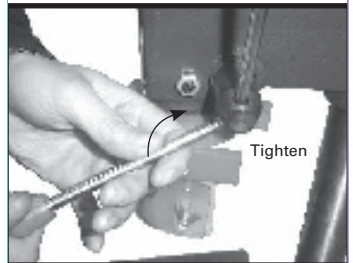

Fig 5



Fig 6

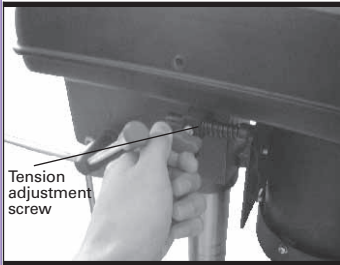

Fig 7

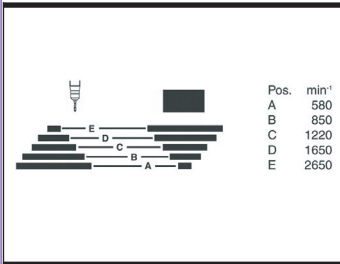

Fig 8

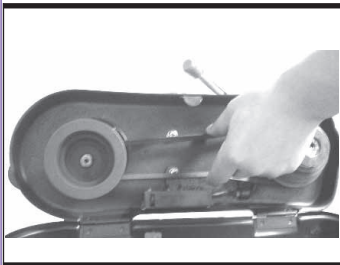

Fig 9

Adjustments to be checked before use

Note: Always disconnect the power supply before making any adjustments on the machine.

Belt tension

Loose the tension adjustment screw located on the side of the machine (See Fig 7). The motor is on a pivot and is locked in position by means of the motor securing bolts. Slacken the screw. Pull the motor towards the front of the machine to slacken the belts and away to tension. Only hand tension and lock the tension adjustment screw.

Operating the bench drill

Selecting the correct speed for different work Refer to speed chart and select the speed required for the job in hand. The machine has 5 speed settings: 580-2650min⁻¹.

Chose the speed setting nearest to the speed given in chart.

Changing the 5 speed setting

Remove the belt cover securing screw. The pulleys and belt are now visible. Slacken the tension and adjustor screw located on the side of the machine and loosen. Pull the motor towards the front of the machine to slacken the belt. Change the belt position according the guide chart inside the belt cover to get the desired speed (See Fig8).

Note: Do not cross the belt to give intermediate speed. Select the required speed and locate belt on pulleys.

Tension the belt

Pull the motor away from the front of the machine to tighten the belt. Only hand tension and lock the tension adjustor screw. Check the belt midway between the pulleys and ensure that there is a total movement of 15mm (See Fig9). If correct, tighten the tension and adjustor screw. Lower pulley guard and secure with the screw.

Work table adjustment

The worktable can rotate +45° to -45°. Slacken the lock nut and rotate the desired angle (See Fig10). Re-tighten lock nut. Slacken the locking lever to the rear of the table (See Fig11). Move up or down the column. When desired height is reached lock into position.

Note: Base can be used as a work table when a

higher work position is needed.

Depth stop adjustment

Bring the drill bit in contact with the work piece to be drilled. Take a measurement from the scale on front of machine (See Fig12). Move work piece and add the amount on to the previous measurement. Move lock nuts down to that required position and lock. This will give a consistent depth when drilling.

Starting and stopping the bench drill

Finally when all adjustment have been completed and you have thoroughly familiarized yourself with the operation, plug into a 13-amp outlet socket situated close to your bench drill.

The machine is fitted with a no volt switch assembly. This means in the event of a power failure when drilling. The motor will not start once the power is restored.

Assembly of the Chuck

Holding the chuck on the spindle, tap with a block of wood hammer or a soft tip hammer to set the chuck onto the spindle. (See Fig13)

Disassembly of the Chuck

Disconnect the bench drill from the power supply. Fit a suitable length bolt through the work table hole, do not tighten it (See Fig14).

Adjust the work table to a suitable height and lock the work table. Move down chuck and tighten the chuck onto the bolt (See Fig15 & 16). Turn handle, move up spindle. Chuck will be pulled off.

Maintenance

Always lubricate drill bits with suitable oil when drilling.

This will prolong the life of drill bits.

Caution: Do not use water-based coolant or any kind of continuous coolant pump.

Remove all swarf and dust after each operation. Spread oil onto unplated surfaces especially if the machine is not used for long periods.

Lubricate the Spindle drive with oil every six months.

Spindle guide screw should be checked periodically to finger tightness.

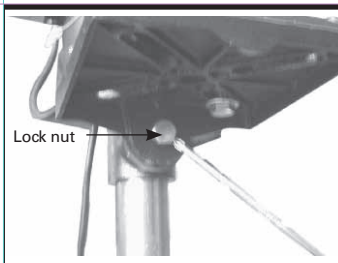

Fig 10

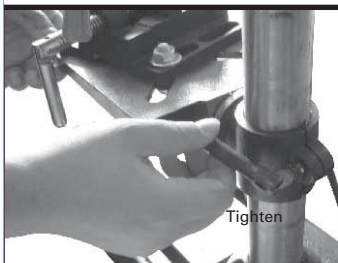

Fig 11



Fig 12



Fig 13



Fig 14

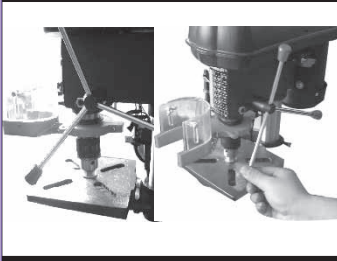



Fig 15&16

ENVIRONMENTAL PROTECTION

 Waste electrical products should not be disposed of with household waste. Please recycle where facilities exist. Check with your Local Authority or retailer for recycling advice.

PLUG REPLACEMENT

The fuse in the main plug of your power tool should always be replaced with one of identical rating.

Check the voltage given on your power tool matches the supply voltage.

The power tool is supplied with a fitted plug, however if you should need to fit a new plug follows the instruction below.

IMPORTANT

The wire in the mains lead are coloured in accordance with the following code:

Green & yellow ---Earth

Blue ---Neutral

Brown ---Live

The wire which is coloured green & yellow must be connected to the terminal which is marked with E or $\frac{\equiv}{\equiv}$.

The wire that is coloured blue must be connected to the terminal that is marked with the letter N.

The wire that is coloured brown must be connected to the terminal that is marked with the letter L.

A 13AMP (BS1363 or BS1363/A) plug must be used and a 5 AMP fuse must be fitted.

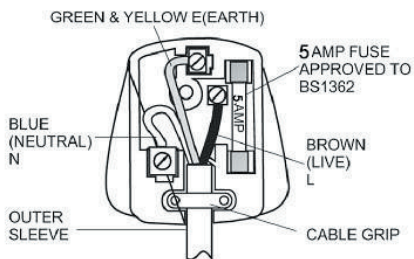



Declaration of Conformity

We, Importer

Screwfix Direct Ltd

Mead Avenue

Houndstone Business Park

Yeovil

BA 22 8RT

Declare that the product

**5 SPEED BENCH PILLAR DRILL
SF13N**

Complies with the essential health and safety requirements of the following directives:

89/336/EEC, 93/68/EEC–EMC Directive.

73/23/EEC, 93/68/EEC–Low Voltage Directive

98/37/EC–Machinery Directive.

Standards and technical specifications referred to:

EN 61029-1:2000

EN 55014-1 /A2:2002

EN 55014-2 /A1:2001

EN 61000-3-2:2000

EN 61000-3-3: /A1:2001

Authorised Signatory

Date: 09/15/05

Signature: P. C. Harries

Name: Peter Harries
Screwfix Direct Ltd
Quality Manager



TITAN®