



CABINET SPECIFICATION

Our cabinets are made up of 18mm panels for maximum durability and incorporate solid backs and soft-close mechanisms as standard for both doors and drawers. All wall cabinets are designed to take 12-inch dinner plates.

1. Easy to install

Concealed wall hanging brackets, with locking mechanism and metallic covers.

2. Soft close drawers

All drawers are double skinned, full extension, with integrated soft close as standard.

3. Soft close doors

All cabinets are supplied with hinges with soft closers included as standard.

4. Anti-tilt shelves

Discreet shelf brackets with anti tilt solution.

5. Rigid construction ready to fit

Cabinets are all glued and dowelled with stapled 4mm HDF backs for additional rigidity.

6. Deep wall units for large dinner plates

330mm deep.

7. Minimum drill holes

We have eliminated all unnecessary holes.

8. Sturdy carcass

Made from 18mm material.

9. Edges do not chip

Edged with hardwearing 1mm ABS edging.

10. Easy to level

With adjustable legs (-9mm to +25mm) for installation on uneven surfaces.

11. Service Void

Base units have a 60mm service void behind the back panels for pipes.

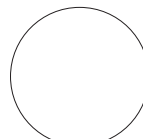

white



oak

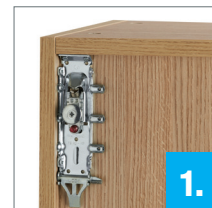

1.

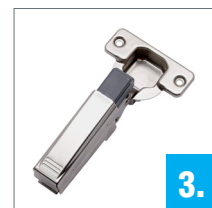

3.



4.



5.

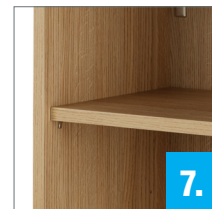

7.



8.



10.



RIGID KITCHENS

GENERAL FITTING INSTRUCTIONS

(A) BASE CORNER

Once the units have been put into position, levelled and fixed to the wall (fig 1), drill through the corner blank panel from inside the unit with a 3mm drill bit and fix the corner post with screws as shown.

The doors on the corner unit should be hinged from the munlin. The hinges on the adjacent unit should be fixed next to the corner post.

Secure the corner post to the adjacent unit using the brackets and screws provided (fig 3)

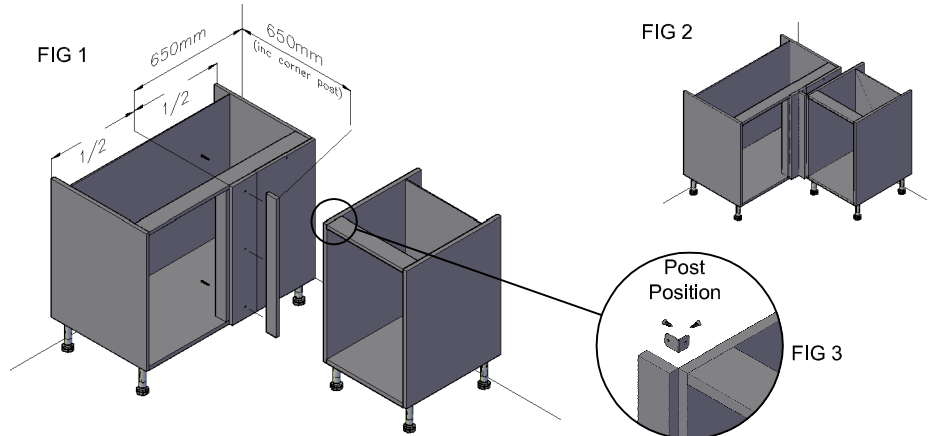

(B) WALL / WALL CORNER

Please refer to the appliance manufacturer's instructions regarding the minimum distance allowed between the appliance and wall units.

Attach the hanging brackets using the pre-drilled holes in the back edge of the unit and lock into position using the bottom locking mechanism (see fig 5).

Hanging plate measurement is to the bottom of the plate. Attach the plate to the wall using suitable fixing, not supplied (see fig 4).

Hang the unit onto the plates and adjust (see fig 5a). Once in position use the bottom (red) screw to lock the bracket into position. On open wall units direct screw through back panel. Secure base of unit using brackets provided (2=single, 3=double).

The doors on the corner unit should be hinged from the corner post. The hinges on the adjacent unit should be fixed next to the corner post.

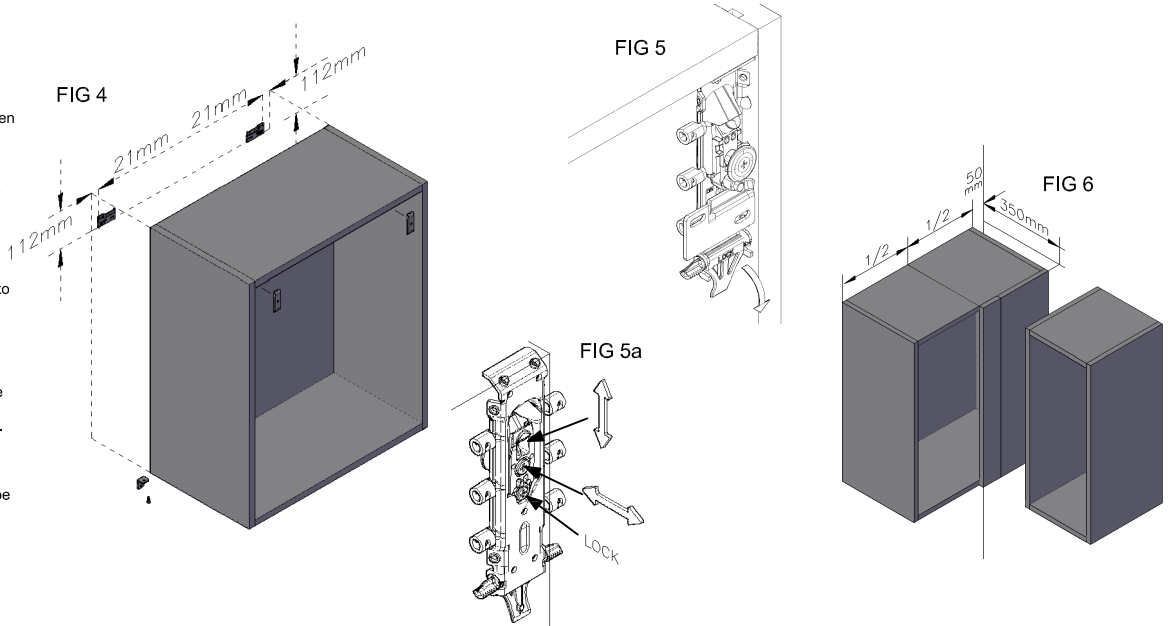

(C) FEET ADJUSTING / LEVELING

Fit adjustable legs to base cabinet by pushing into pre attached leg bosses (see fig 7). Rotate the legs to adjust the desired level of the unit. Once level, the unit should be secured to the wall using the bracket attached to the cabinet. (use appropriate fitting for wall type). Units can be joined together by screw fixing through adjacent end panels.

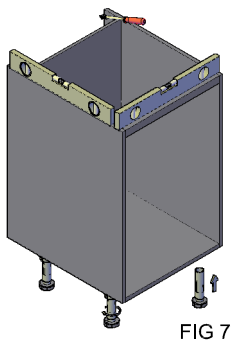

(E) CLIP HINGE FIXING

To attach door (see fig 9,10), connect hinge lugs to plate first then push back of hinge onto plate until it clicks into position.

Due to multiple hinge plate drillings, align door with hinge plate attached to correct hinge plate marks on unit (as shown) and fix into position (see fig 11).

To remove door (see fig 9, 10), push back clip and ease the hinge off the front lugs (always remove the bottom hinge first).

To remove the soft close mechanism lift off the back first then remove via the front lugs.

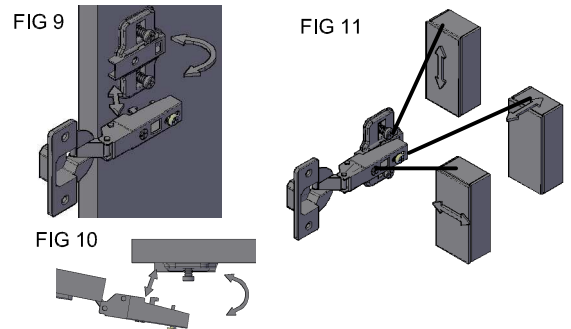

(D) PLINTH FITTING

Cut the plinth to the required length, lay the plinth on the floor in front of the units/legs, mark off the leg position and screw fix the support clips to the back of the plinth, push the plinth onto the legs so that the clips locate over the leg (see fig 8).

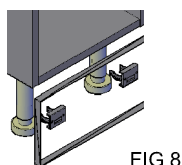

(F) HANDLE DRILLING

Drill a 1mm pilot hole through from the rear face, then turn over the door and drill a 5mm hole through the face, it is advisable to drill into a spare piece of wood to prevent break through. Fix the handle with the screws provided.

(G) DRAWER ADJUSTMENT

Fig 12 shows how to adjust the drawer front.

To fit drawer into carcass tilt drawer upwards then locate onto runner and push into place. To remove, reverse procedure.

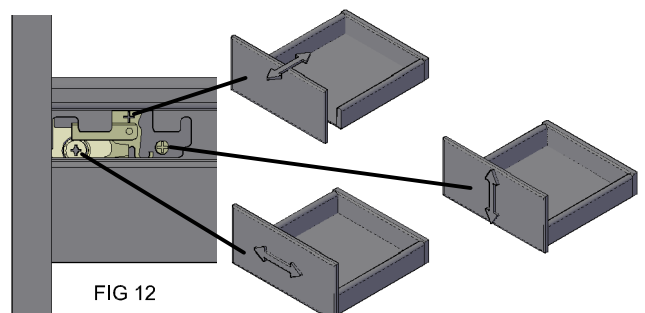

(H) Multi Drawer

Drawer box runners to be secured into pre drilled holes (3drw & 4drw) in end panel (see fig 13).

For drw box assembly refer to instruction sheet in drw box kit.

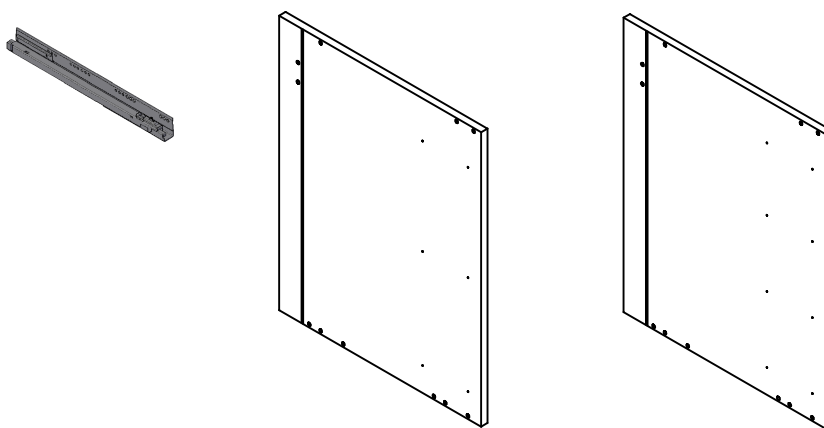

(I) SHELF BEARERS/RETAINER

Fit shelves into position using metal bearers provided once into position retain using clear stick on retainers.

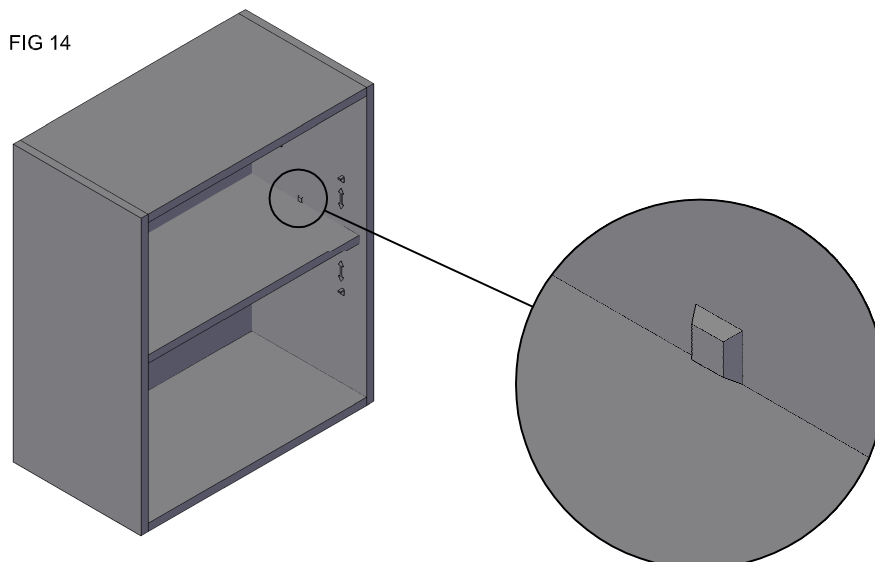

CARE OF UNITS

Units.

Screw fittings should be checked regularly to ensure that they are secure to prevent excess strain on the furniture. Do not place heavy weights on partially open doors or drawers.

Avoid using strong chemicals or abrasive cleaners. Use warm water with a mild detergent and a damp cloth. Once cleaned, remove any excess moisture with a clean dry cloth.

On wooden doors use a furniture polish. With natural timber you may notice some colour and grain variation, this will diminish over time as the wood is exposed to natural light.

Frontages.

All frontages should be treated with care to maintain their good looks and performance.

Never use abrasive cleaners or strong chemicals. Melamine or laminates are best cleaned with a damp cloth, warm water and a mild detergent.

Do not allow water to stand on surface always wipe dry immediately with a soft, clean cloth. Clean and protect with furniture polish. Prevent marking or scratching by eliminating the risk of contact from sharp or heavy objects.

Worktops.

For routine cleaning, use a damp cloth or sponge and a mild soap or detergent. On more stubborn stains apply a mild non-abrasive household cleaner/detergent with a soft bristled brush.

Always use a cutting board - sharp knives can damage any laminate surface. Never place hot pans, dishes directly on worktops.