

Assembly guide

Cupboard Pull out Basket:

Component parts

Tools required (Not Supplied)

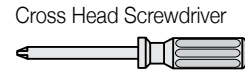
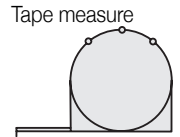
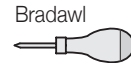
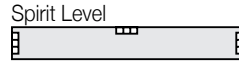
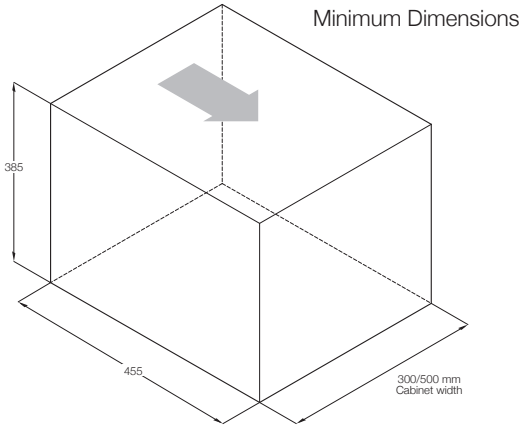

Did you know Häfele also supply tools to the trade and industry?
See www.hafele.co.uk for more information.

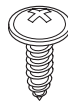

4.5 x 15 mm
Panhead Screw
(C) x 16 pieces



2 mm Spacer
(D) x 8 pieces



4 x basket fixing
clamps (E)



4 x dome nuts (F)

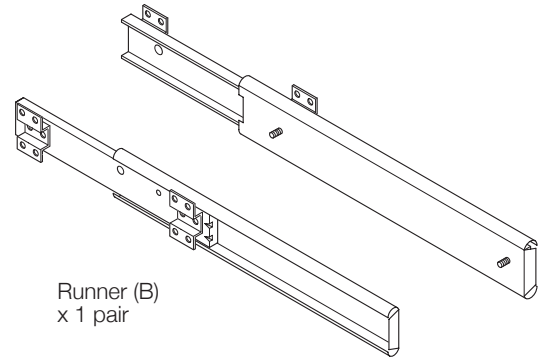

4 x washers
used with 19/20 mm
carcase

- 1** Using the runner drilling pattern shown in diagram 1, fix the runner (B) using 16 x 4.5 x 15 mm panhead screws (C) to the internal side of the carcase with the bottom runner fixing point a minimum of 55 mm up from the floor level of the cabinet. Then add the required no. of spacers for the carcase thickness being used to the threads on each runner.

Board thickness	Total no. of spacers to be used on each side of the cabinet
15 mm	2
16 mm	2
18 mm	1
19 mm	1/0

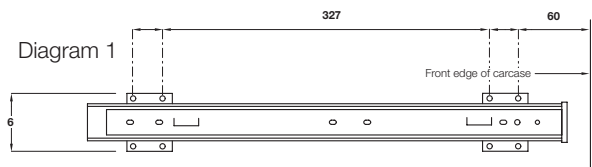

- 2** To fit the basket extend the runners to their full extension. Then using the bottom wire, fix the basket (A) to each side of runner (B), as shown in diagram 3 using the basket clamps (E) and the dome nuts (F).
Please note:
A washer should be used under each dome nut only when fixing to a 19/20 mm carcase.

