

PREPARATION MAGNUM WALL TABLE

F20609Z

Magnum wall tables will align with the Magnum range of catering sinks. Magnum wall tables are manufactured from 1.2 thick austenitic grade stainless steel polished to a satin finish. Stainless steel underframes complete with shelf are supplied with each table, in a flat pack form with easy to read assembly instructions. Each leg is fitted with an adjustable foot (-20, +10mm) with a working height of 900mm. Magnum Wall Table with Flatpack Underframe

ARTICLE NUMBER

F20609Z

EAN 7612979002911

TECHNICAL DATA

Material	stainless steel
Material code	1.4301 Chrome Nickel steel V2A
Material thickness	1.2 mm
Surface finish	satin finished
Gross weight	20 kg
Type of mounting	floor mounting
Overall width	1200 mm
Overall height	900 mm
Overall depth	700 mm
Rear upstand	yes

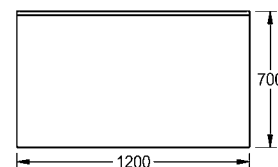
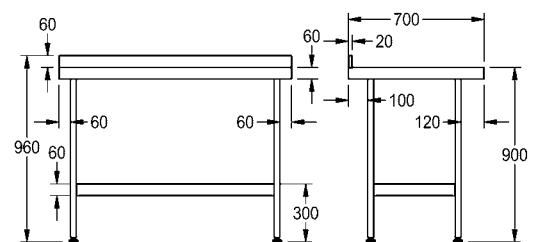

Franke Washroom Systems
ws-info.uk@franke.com
www.franke.com

2012-09-04, Franke WS

FRANKE

Franke Sissons Ltd., Carrwood Road, Sheepbridge, Chesterfield, S41 9QB
Telephone: 01246 450255 Fax: 01246 451276 E-mail: ws-info.uk@franke.com

Assembly instructions for underframes supplied with Franke Sissons catering sinks and preparation tables

Contents of stand pack

Item	Description	(without centre leg) QTY	(with centre leg) QTY	Models fitted with centre leg
A	Legs	4 (2 LH & 2 RH)	6 (2 LH, 2 RH & 2 centre)	E20617D E20618D E20619D
B	Plastic leg inserts	4	6	E20620D
C	Plastic screw feet	4	6	E20627D
D	Shelf	1	2	E20628D
E	10mm Stainless steel Hexagon nuts	4	8	E20635L/R
F	10mm Stainless steel washers	4	8	E20636L/R
G	8mm fixing screws	4	6	E20637L/R
H	8 mm stainless steel washers	4	6	E20638D
I	Shelf clamping cleats	4	8	E20639D E20640D

NB A mallet will be required for the plastic feet assembly and 12mm and 17mm box spanners for tightening the fixings.

In pursuance of our policy of continued development we reserve the right to alter designs and specifications without prior notification©2006

NOTE: CHECK PARTS AGAINST THE CONTENTS TABLE

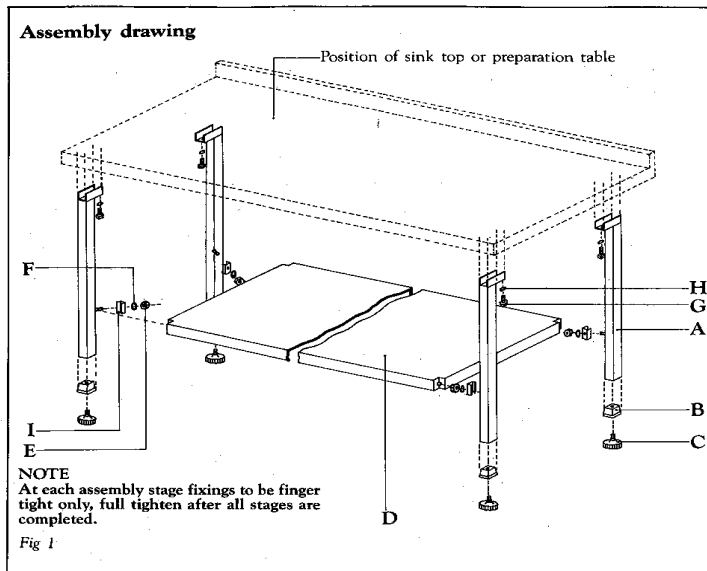

NOTE

The above sketch shows the general exploded view in order to assist with the assembly of the underframe. However for the fixing of the undershelf to the leg support please follow the instructions in figure 4 - This relates specifically to the positioning and fixing of parts E, F and I, which are to fit on the inside of the undershelf, and not in the position as shown on the exploded view.

NOTE

The above sketch shows the general exploded view in order to assist with the assembly of the underframe. However for the fixing of the undershelf to the leg support please follow the instructions in figure 4 - this relates specifically to the positioning and fixing of parts E, F and I, which are to fit on the inside of the undershelf, and not in the position as shown on the exploded view.

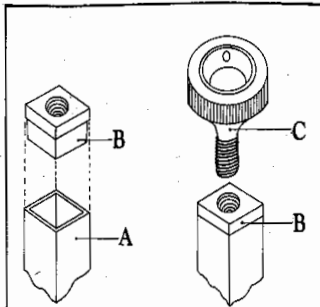

Fig 2

Gently tap the plastic feet inserts (B) into the bottom of the legs (A) using a mallet to ensure a full location. Repeat procedure on all legs.

Screw in plastic feet (C) into leg inserts (B). Repeat procedure on all legs.

Centre leg details

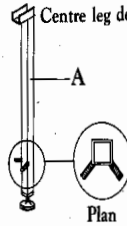
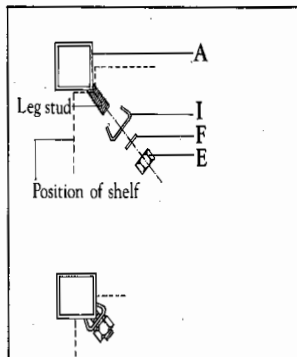

Fig 3

Locate the shelf (D) on to the leg studs ensuring that the channel at the top of the legs (A) face each other, i.e. point inwards. Make sure that the shelf is the correct way up. SEE FIG. 1.

NB. For stands with centre legs (studs on two opposite sides as shown in sketch above) locate the shelves (D) on to the centre legs first. The leg channels are located to the top with screws which are tightened by means of a screwdriver.



Plan showing completed fixing

Fig 4

Ensure that the corner of the shelf (D) fits around the studs and legs (A) correctly. Place a self clamping cleat (I) over the leg stud and fix in position with a 10mm washer (F) and 10mm hexagon nut (E). Repeat procedure on all legs.

Assembly of stand to sink top or preparation table

1. Lay the sink or preparation table face down ensuring that the polished surface is protected from the floor.
2. Turn the stand assembly upside down and locate the leg channels on to the struts on the underside of the sink or preparation table ensuring that the holes in each line up.
3. Screw the legs to the sink or preparation table using the 8mm screws (C) and 8mm washers (H).
4. Fully tighten all the screws and nuts.
5. Remove the protective plastic coating from the shelf (D) and the sink or preparation table.
6. Adjust the plastic feet (C) to ensure that the completed unit stands level.