

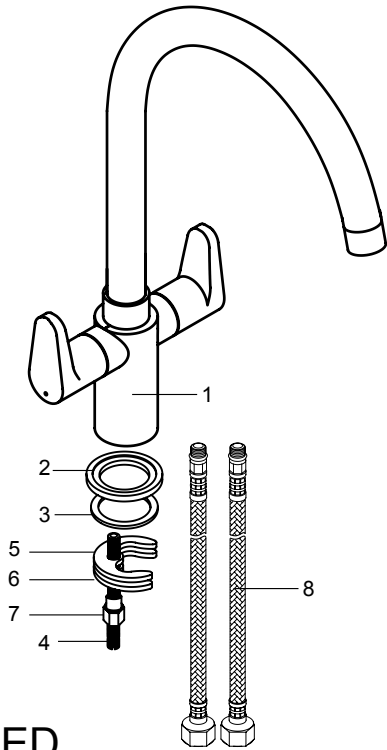

# Fitting Instructions

## Mono Sink Mixer



### PARTS SUPPLIED

ITEM	DESCRIPTION	QTY
1	Tap Body	1
2	Flange (If Supplied)	1
3	Anti-Rotational Washer	1
4	Fixing Studs	1
5	Rubber Horseshoe Washer	1
6	Metal Horseshoe Washer	1
7	Fixing Nut	1
8	Braided Connectors	2

### BEFORE YOU START

This tap is suitable for use at water supply pressures of 0.1 bar (min.) to 7bar (max.).

If the tap is installed into a low pressure (tank fed) system, the minimum height from the outlet of the nozzle to the underside of the water tank should be at least 2 metres to ensure adequate performance.

This product must be connected to water supply in accordance with the Water Supply (Water Fittings) Regulations 1999, and also to comply with UK Building Regulations. If you are in any doubt about these requirements, contact a qualified plumber, your local Water Company or the Water Regulations Advisory Service(WRAS).

- Identify all components and check pack contents.
- TURN OFF WATER MAINS SUPPLY.** The mains stopcock is usually situated where the supply enters the building.
- It is also recommended that the water heating arrangements are turned off.
- Isolate the hot and cold water supply.

### INSTALLATION

- Fit Fixing Studs (4) to the Tap Body (1).
- Make sure that Anti-Rotational Washer (3) has been fitted to Flange (2).
- Assemble Flange (2) to tap body and Screw 2 x Braided Connectors (8) into Mixer Tap Body (1) . Locate the tap assembly down through the hole in the basin.
- Fit Rubber Horseshoe Washer (5) onto Fixing Studs(4). Fit Metal Horseshoe Washer (6) and fit Fixing Nut (7) onto Fixing Studs (4). **DO NOT OVERTIGHTEN.**
- Bend the Braided Connectors (8) as necessary and connect to the water supply using suitable plumbing joints.
- Turn on the water supply and re-fill the system. Check immediately for leaks. It is always advisable at this stage to flush out the system. To do this, open both valves fully and allow water to flow for approximately 1 minute. This will remove any foreign matter within the Tap Body.
- Finally turn on all the water heating arrangements.

### AFTER CARE

To maintain the appearance of this fitting, ensure it is cleaned only using a clean soft damp cloth.

A solution of warm water and mild liquid detergent may be used where necessary and then rinsed thoroughly. Abrasive cleaners or acidic cleaners **MUST NOT BE USED** under any circumstances. Avoid contact with solvents.