



Victoriana

Fitting Instructions



THERMOSTATIC VALVE

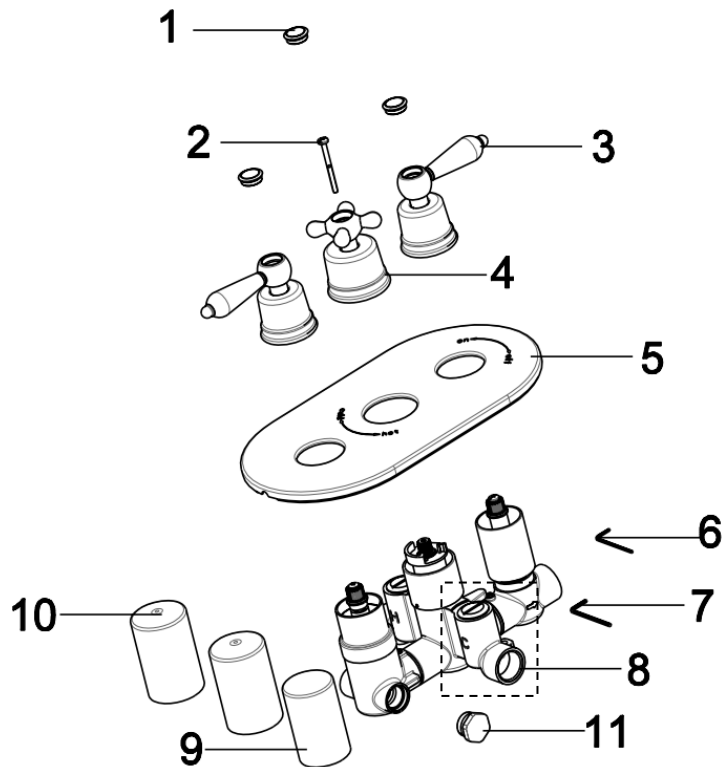

Check Valve Inside to
Prevent Water Backflow

PARTS SUPPLIED

Item No.	Description	Quantity
1	Index Card	3
2	Screw	1
3	Ceramics Handle Set	2
4	Cross Handle Set	1
5	Wall Panel	1
6	Allen Key H2.0	1
7	Allen Key H2.5	1
8	Body	1
9	Protect Cover	1
10	Protect Cover	1
11	Brass End Stop	1

Remark : **Brass end stop must be used if shower jets are not installed.**

DIMENSION (mm)

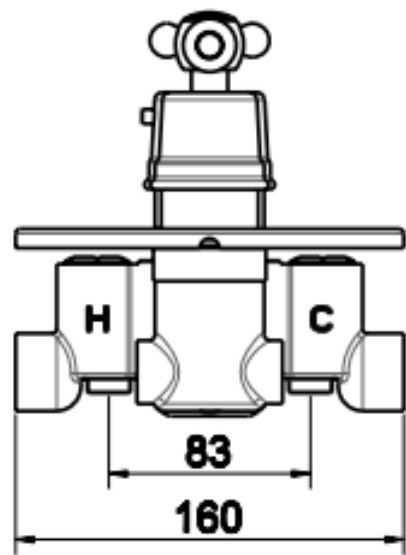
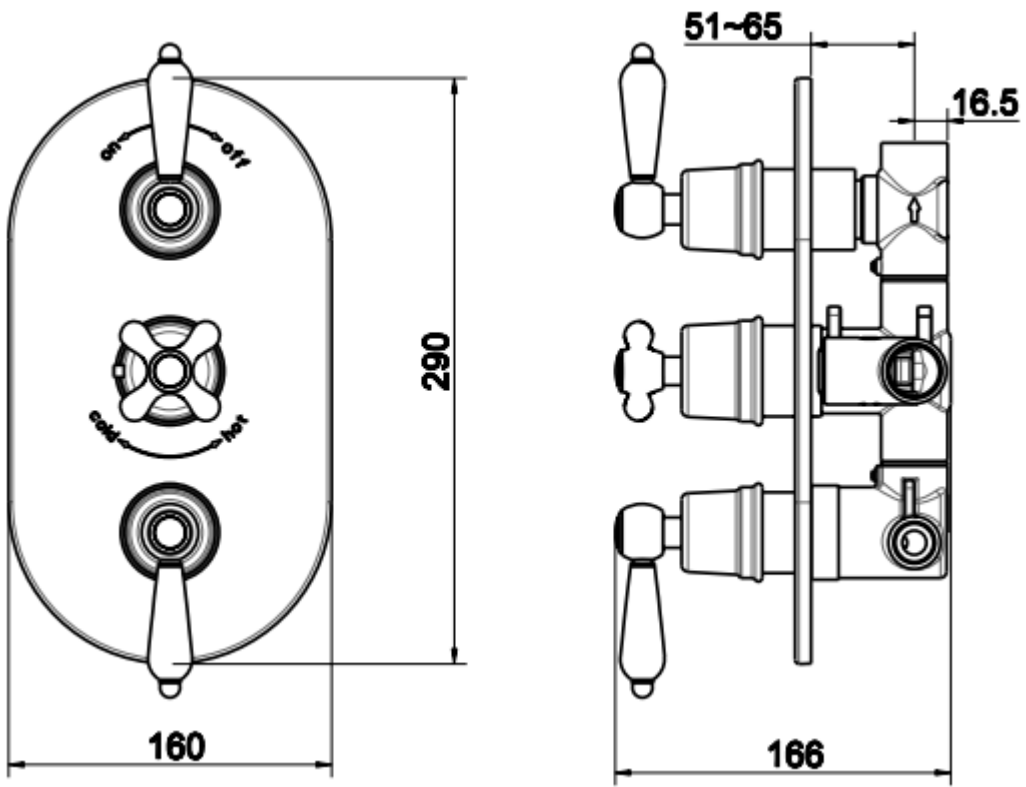

SPECIFICATION

Operating Temperatures

Maximum hot water supply temperature: 70°C

Recommended hot water supply temperature: 60-65°C

Maximum temperature is factory-set to 46°C

Always maintain a 10°C difference between hot system temperature and maximum hot setting of valve.

The difference between the hot and cold water pressures should be no more than 2 bar. If the difference is greater than this, pressure reducing valves (not supplied) should be fitted to the water supplies.

Operating pressures on hot and cold water feeds should be kept as even as possible in order to ensure the maximum efficiency of the mixer.

When water pressure is higher than 5 bar, pressure reducing valves (not supplied) must be fitted before the mixer.

Flow restrictors (not supplied) can be fitted into the wall unions to reduce water consumption on a high pressure system.

Operating Pressures

Min 0.5 bar - Max 5.0 bar

BEFORE YOU START

This product must be connected to a water supply in accordance with the Water Supply (Water Fittings) Regulations 1999, and also to comply with UK Building Regulations. If you are in any doubt about these requirements, contact a qualified plumber, your local Water Company or the Water Regulations Advisory Service (WRAS).

Caution: care should be taken when drilling walls to avoid any sunken wires or pipes

- a. Identify all components and check pack contents.
- b. Turn off the water supply.
- c. It is also recommended that the water heating is turned off.
- d. Isolate the hot and cold supply pipes and drain both water systems. It is recommended to ensure complete drainage, that all taps are open. There is no need to drain the heating system.
- e. Shower valve shown in diagrams are for illustration purposes only.

INSTALLATION

1. An independent water supply (both hot and cold) is required for the shower system.
2. Hot water supply **MUST** always be on the **LEFT** inlet.
3. The inlet pipes should be 130mm apart and 18mm from the back wall.
4. The upper outlet pipe should be 98mm above the centreline of the inlet pipes.
5. The lower outlet pipe should be 32mm apart and 18mm from the back wall.
6. The supply pipes should be inserted approx 10mm into the valve.
7. Each shower valve is supplied with integral check valves in the hot and cold inlet to prevent cross flow and cross contamination of water supplies.

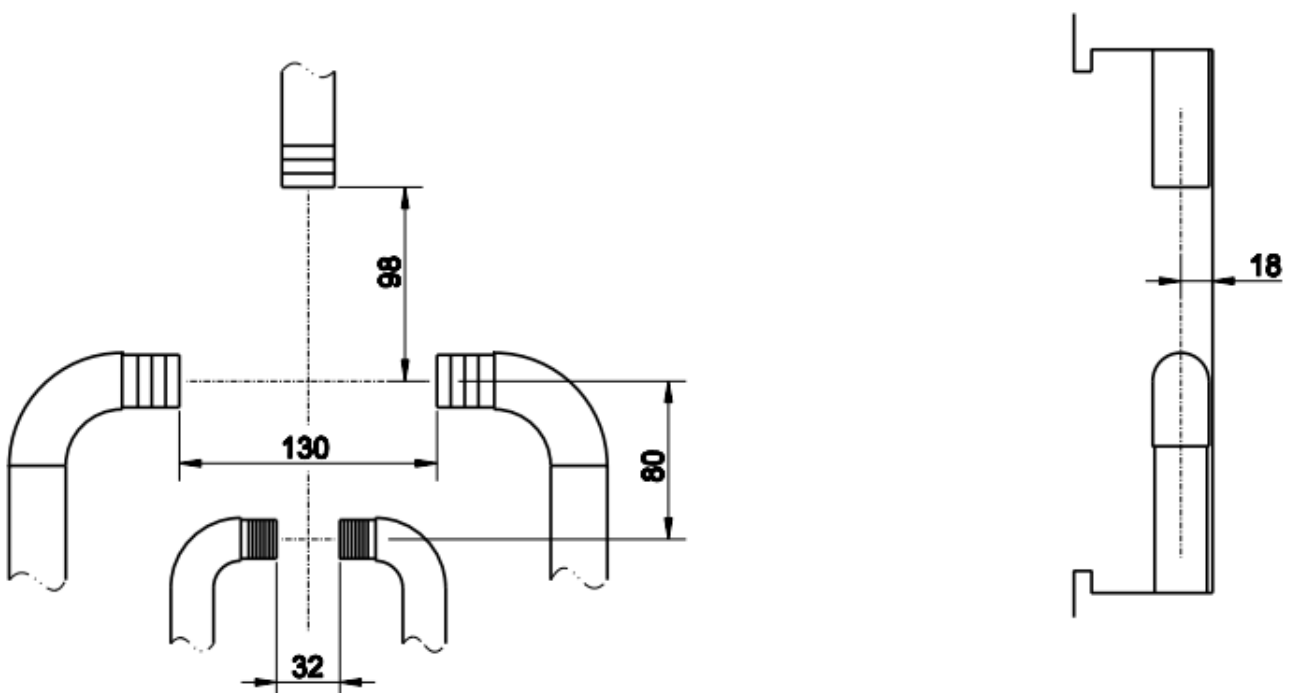

VALVE INSTALLATION

1. Pipework should be flushed and installed before commencing installation.
2. Prepare a cavity in the wall, ensuring the size of the hole does not exceed the size of the Wall Panel (5).
3. Using a pencil or marker pen, make two marks on the wall in a suitable position for the Body (8). Drill the holes using a suitable drill bit. Push the Wall-Plugs flush into the wall.
Fig 1

NOTE: Wall plugs are not supplied. Ensure correct wall plugs for wall type are used; if in doubt seek professional advice.

4. Ensure inlet pipes and outlet pipes are in the correct position. Adjust if required.
5. Offer the valve to the wall and hold in place with the screws. Attach the inlet pipes and the outlet pipe to the valve body. Fig 2

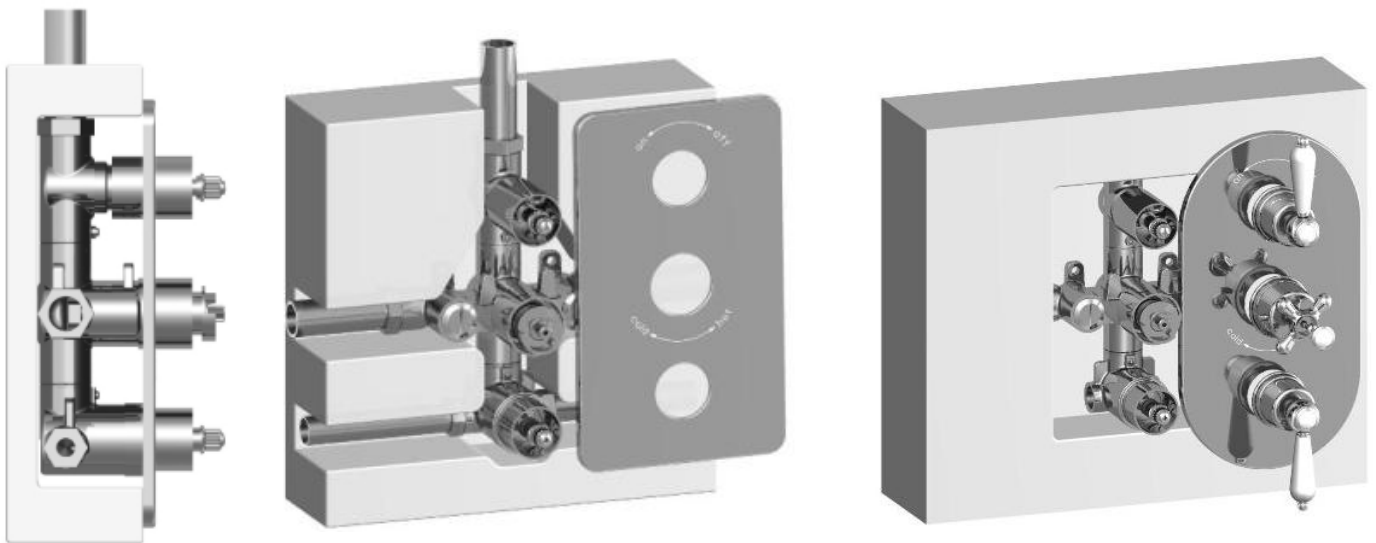

Shower valve shown in diagrams are for illustration purposes only.

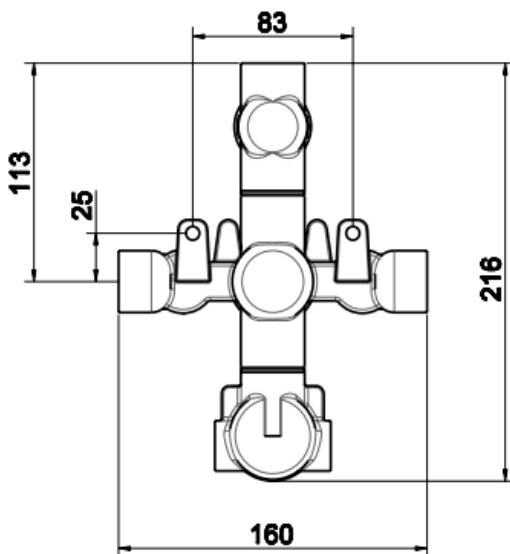

Fig.1

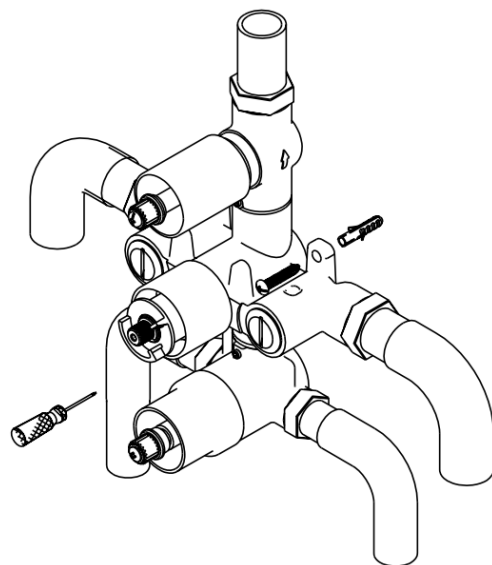
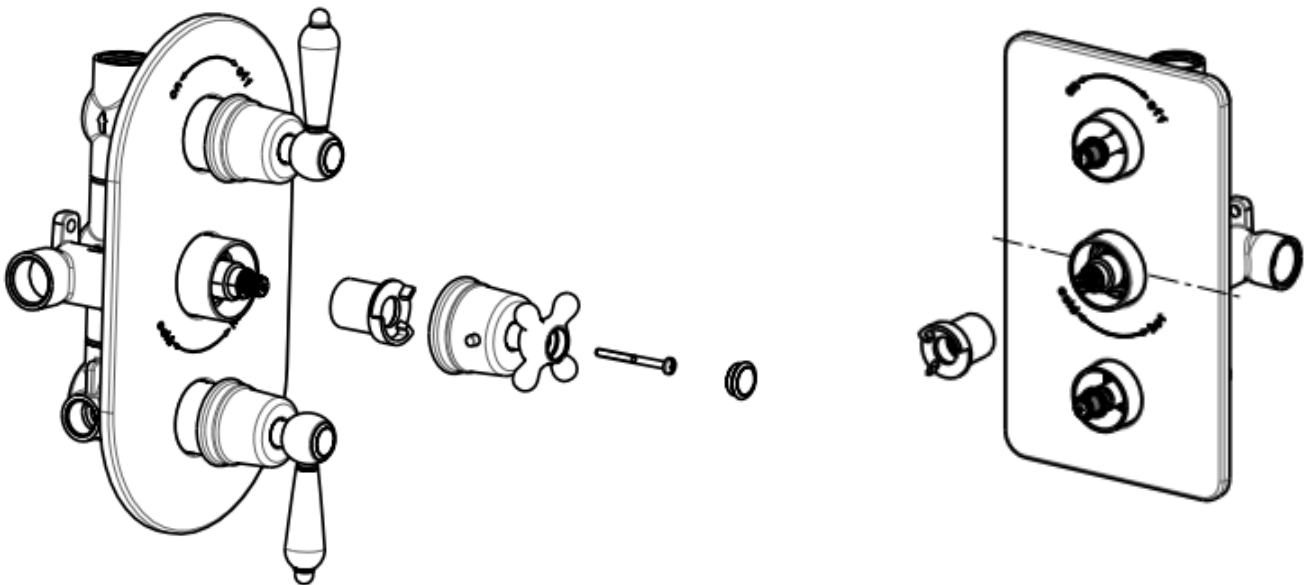

Fig.2

6. Take off the two Covers (9 & 10).
7. Carefully push the Wall Panel (5) over the valve.
8. Re-fit the handles. Follow the steps below to install the flow handle, the thermostatic handle and diverter handle.
 - Turn the stem of the Cartridge (flow rate) clockwise until it stops.
 - Put the Handle (flow rate) over the stem ensuring it is straight, and fit the cap (1) onto handle.
 - Make sure the tail point of **Temperature setting guide** is horizontal (when seen from the operating position).
 - Fit Cross Handle(4) over **Temperature setting guide** with Screw(2), and fit the cap (1) onto handle.
 - Push the Safety Button over the stem, ensuring the shape of lever is “X”.
 - Ensure the stem of the Cartridge (diverter) is right in the middle.
 - Put the Handle (diverter) over the stem ensuring it is straight, and fit the cap (1) onto handle.
 - After fitting the three handles, check the Safety Button function.



Calibration of Water Temperature

The thermostatic mixing valve is factory preset at a mixed temperature of 38°C. Site conditions and personal preference may dictate that the maximum temperature needs to be reset and we suggest the maximum set temperature is 41°C. Care should be taken when altering the setting as **INCORRECT CALIBRATION CAN CAUSE INJURY.**

ADJUST THE MAXIMUM TEMPERATURE

1. Isolate the water supply
2. Take off the cap (4) of temperature control handle (4).
3. Remove the temperature control handle (4) by loosening the screw (2). Pull out the **Temperature setting guide** along the stem.
4. To increase the set maximum temperature, rotate the stem in an anticlockwise direction. To decrease the set maximum temperature, rotate the stem in a clockwise direction.
5. Put the **Temperature setting guide** back over the stem. Make sure the tail point of **Temperature setting guide** is horizontal.
6. Push the Safety Button and refit the temperature control Handle (4). Ensure the lever of handle shape is "X".

Warning:

1. When rotating the **Temperature setting guide** to increase the set maximum temperature, turn 10~15° each time to avoid scalding. After adjustment, check the outlet temperature using a thermometer. Note that the maximum temperature should not be more than 46°C.
2. This product is not suitable for instantaneous electrical or gas water heaters.

CLEANING

Through years of use impurities can restrict the flow of water through the filters of the mixer. If the mixers performance deteriorates, the filter net may need to be cleaned or replaced. The following procedure explains how to replace the filter net.

1. Shut down water supplies to mixer.
2. Take off the Thermostatic Handle (4), pull off the Flow Rate Handle (3) and Diverter Handle from the mixer.
3. Take off the Wall Panel (5).
4. Unscrew the Adjusting Base using slotted-head screwdriver then pull it off the mixer.
5. Wash the Filter which assembling with the Adjusting Base under running water.
6. Before refitting the Adjusting Base, clean the mixer housing and grease the O-Rings.
7. Refit the Adjusting Base, the Wall Panel and handles.

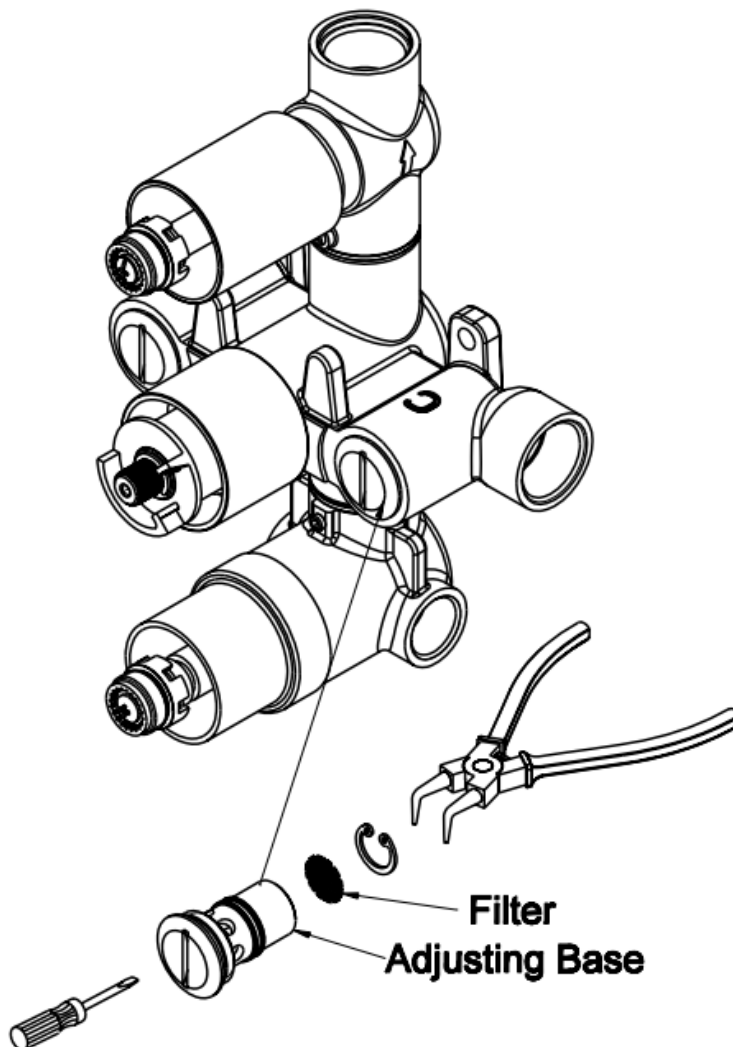

AFTER CARE

Clean using a soft, damp cloth or warm, soapy water only. Do not use scourers, abrasives or chemical cleaners.

PLEASE RETAIN THESE INSTRUCTIONS FOR FUTURE USE.