

Item	Description	Qty
1	Tap Body	1
2	Pop-up rod	1
3	Washer (Anti-Rotational)	1
4	Rubber Horseshoe Washer	1
5	Horseshoe Washer (metal)	1
6	Fixing Studs	1
7	Fixing Nuts	1
8	Pop-up fixing link	1
9	Pop-up waste	1
10	Braided connector	2

Before you start

This mixer is suitable for use at water supply pressures of 0.1 bar (min.) to 7 bar (max.).

If the tap is installed into a low pressure (tank fed) system, the minimum height from the outlet of the nozzle to the underside of the water tank should be at least 2 meters to ensure adequate performance.

This product must be connected to the water supply in accordance with the Water Supply (Water Fittings) Regulations 1999, and also to comply with the UK Building Regulations. If you are in any doubt contact a qualified plumber.

- (a) Identify all components and check pack contents.
- (b) **Turn off mains water supply.**
- (c) It is also recommended that the water heating arrangements are turned off.
- (d) Drain the cold and hot water system. It is recommended to ensure complete drainage.

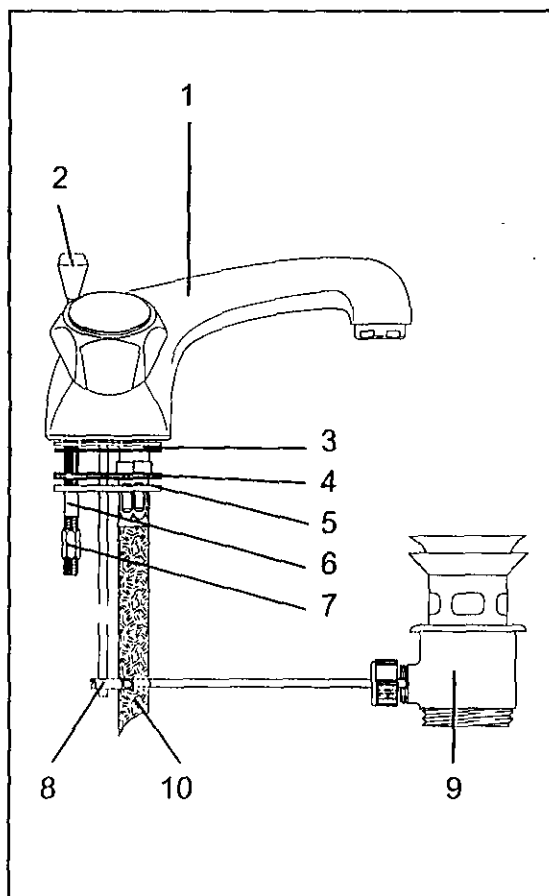

Fitting Instructions

Contract Mono Basin Mixer

Installation

- 1 Screw 2x braided connectors (10) to tap body.
- 2 Fit fixing studs (6) to tap body.
- 3 Fit anti-rotational washer (3) to tap body.
- 4 Locate the tap assembly down through the hole in the basin.
- 5 Fit rubber horse shoe washer (4) onto threaded studs (6). Fit metal horse shoe washer (5) and fit fixing nuts (7) onto fixing studs (6). Do not over tighten.
- 6 Fit braided connectors (10) to the water supply using suitable plumbing joints.
- 7 Fit pop-up waste assembly (9) to the basin.
- 8 Push pop-up rod (2) through tap and connect to pop-up waste (9) rod using pop-up fixing link (8).
- 10 Turn on the mains supply and re-fill the system. Check immediately for leaks. It is always advisable at this stage to flush out the system. To do this open both valves fully and allow water to flow for approx 1 minute. This will remove any foreign matter within installation.
- 11 Finally turn on all water heating arrangements.

After Care

To maintain the appearance of this fitting, ensure it is cleaned only using a clean soft damp cloth. A solution of warm water and mild liquid detergent may be used where necessary and then rinsed thoroughly. Abrasive cleaners or acidic cleaners **MUST NOT BE USED** under any circumstances. Avoid contact with solvents.