



Nothing but **HEAVY DUTY.**[®]



M18 FMCS

Original instructions

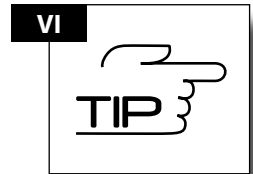
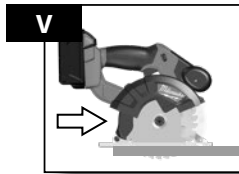
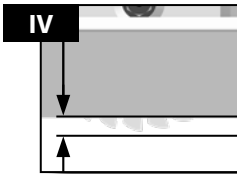
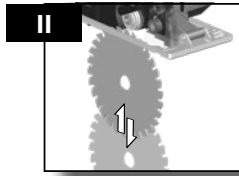
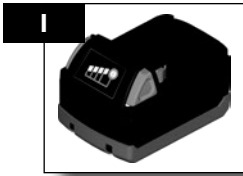
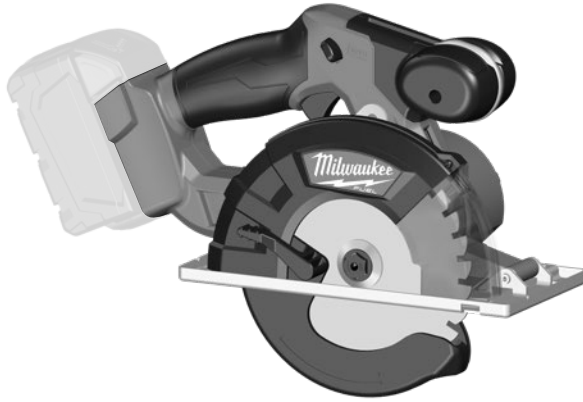

VII Technical Data, Safety Instructions, Specified Conditions of Use, Declaration of Conformity, Batteries, Maintenance, Symbols
Please read and save these instructions!



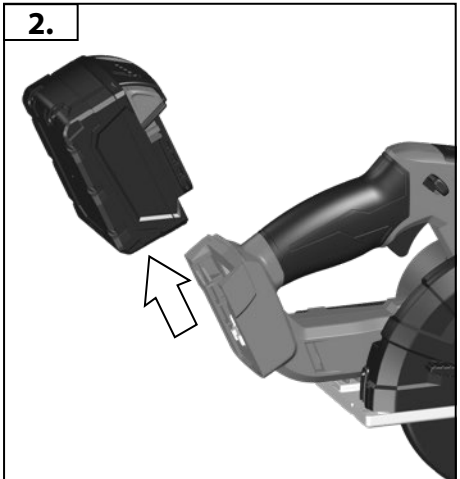
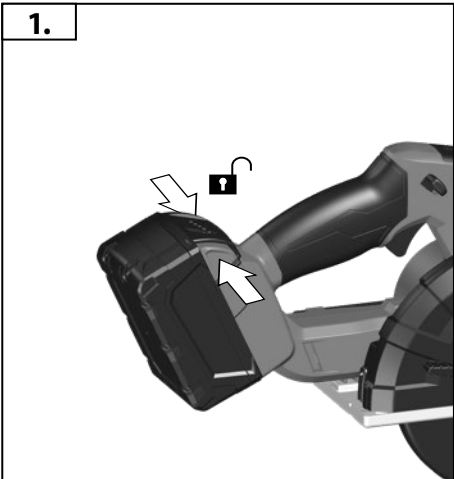
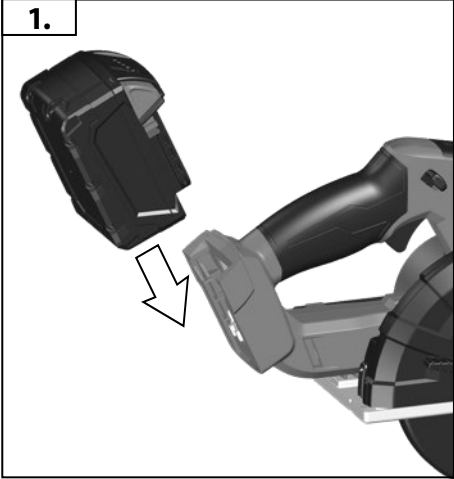

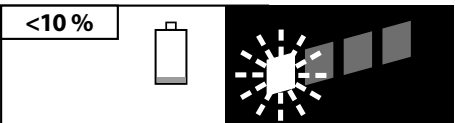
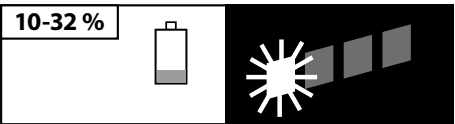
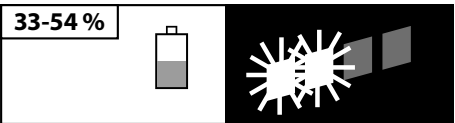
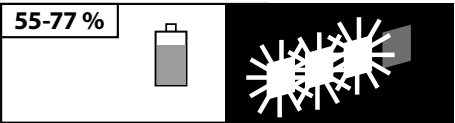
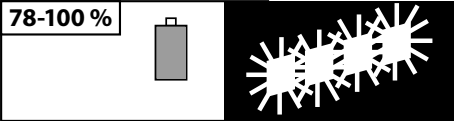
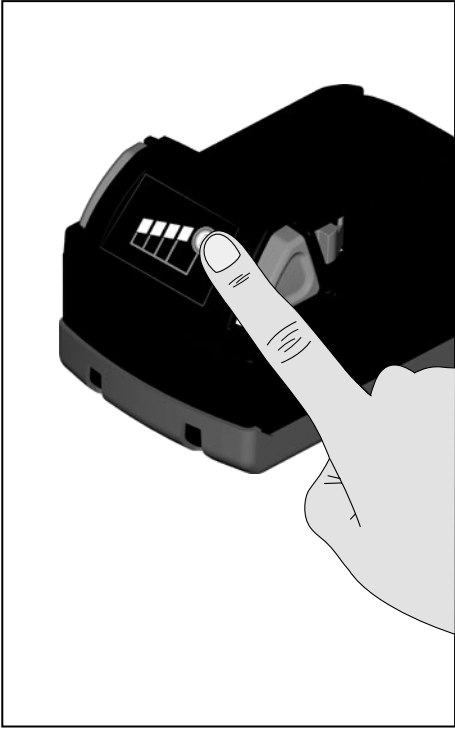

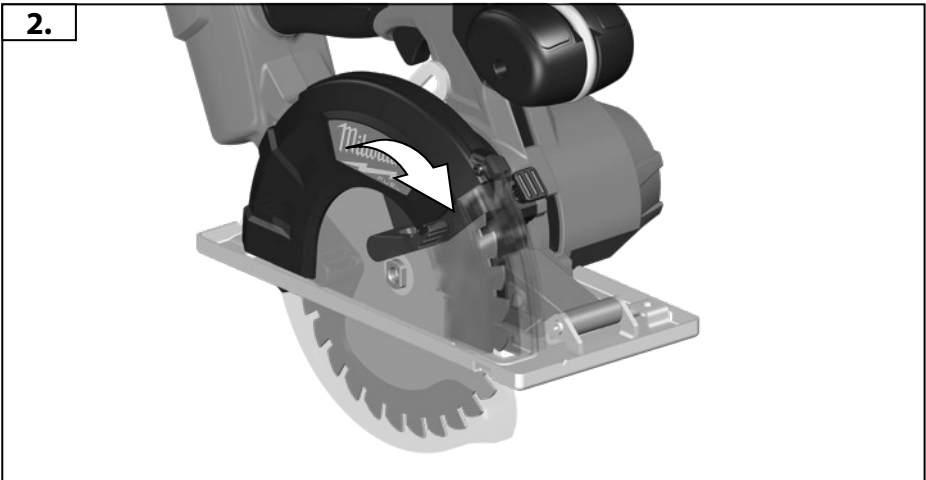
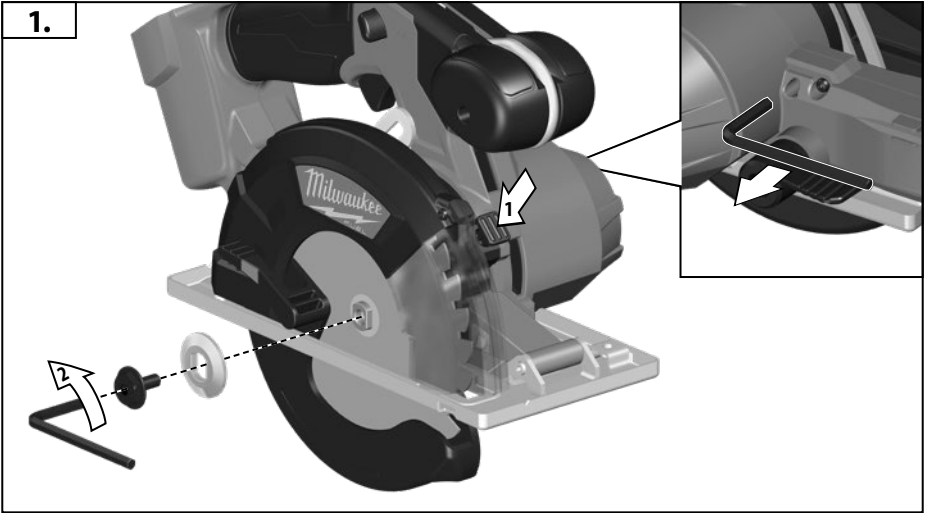
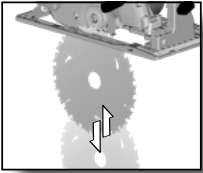

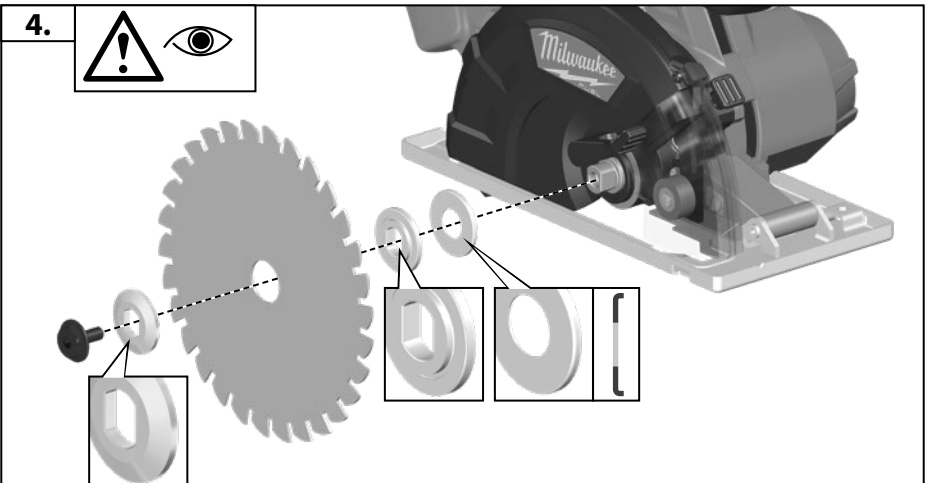
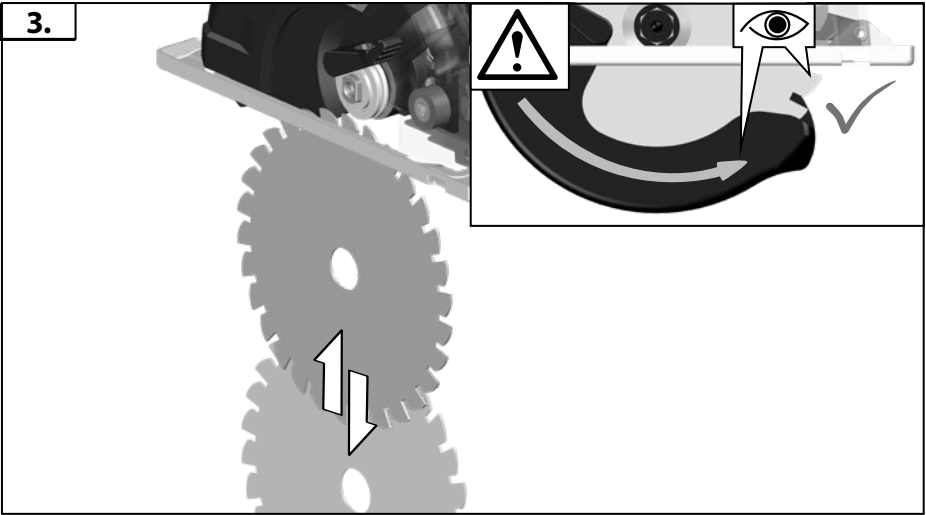
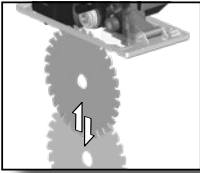

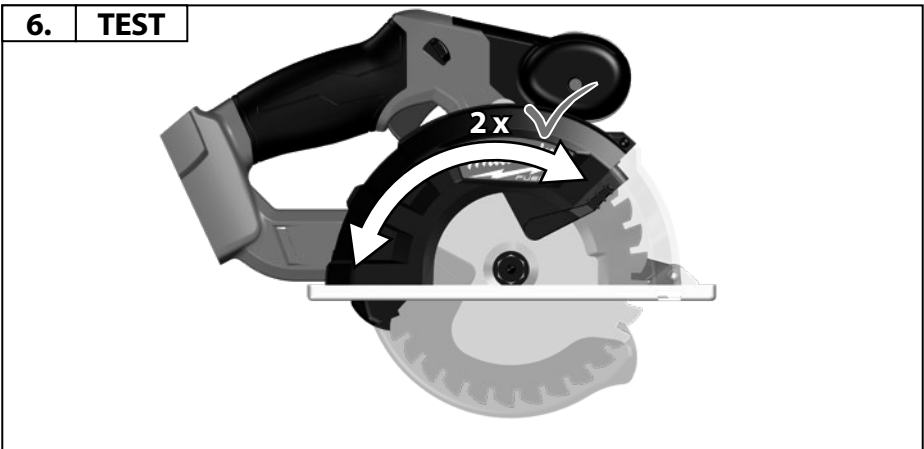
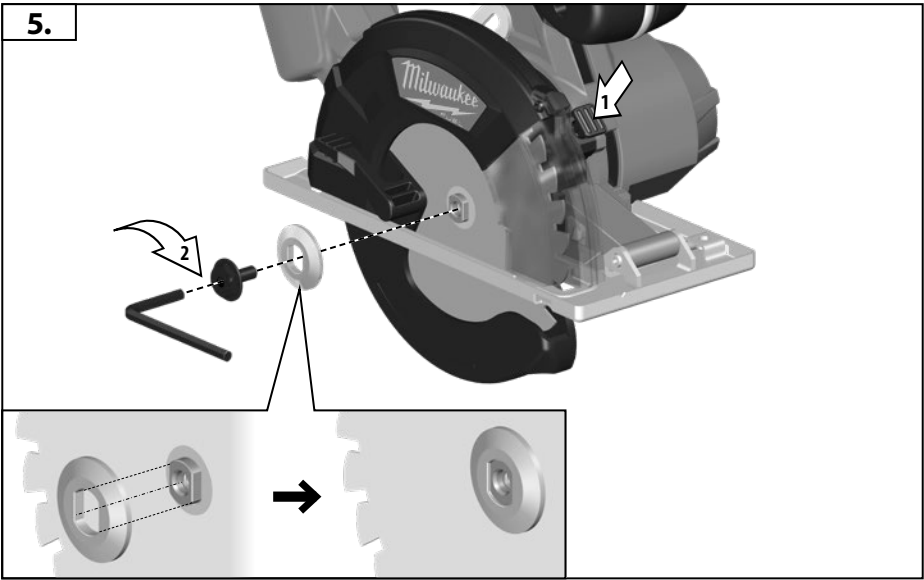
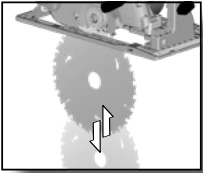

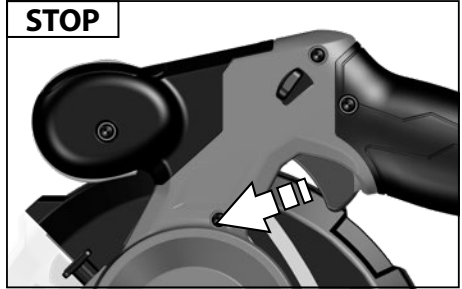
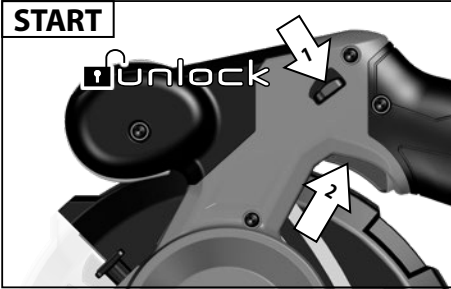

For safety reasons this power tool is fitted with a switch lock and the On-/Off switch cannot be locked in the „On“ position



START
STOP
≡

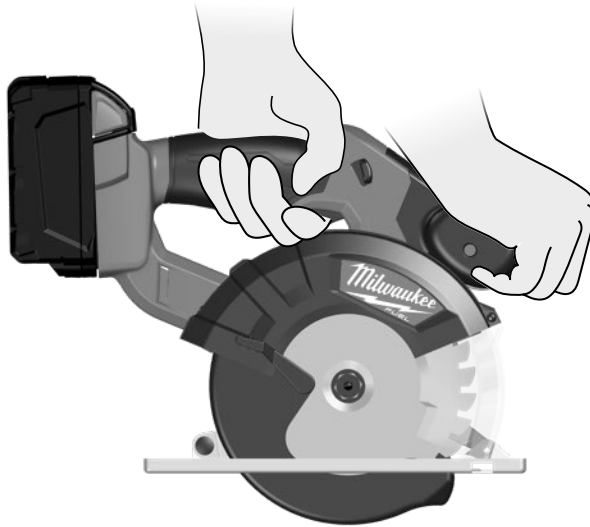

Insulated gripping surface

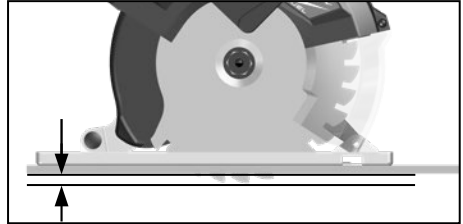
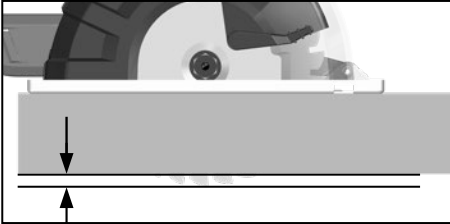
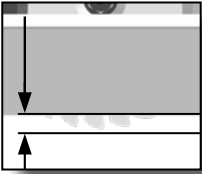

Adjust the cutting depth to the thickness of the workpiece. Less than a full tooth of the blade teeth should be visible below the workpiece.

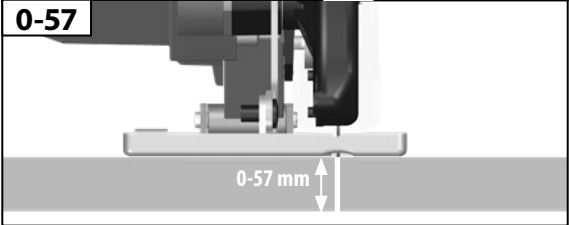
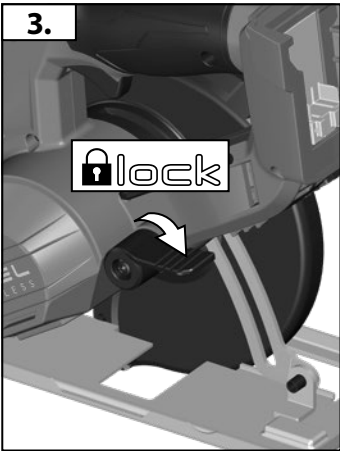
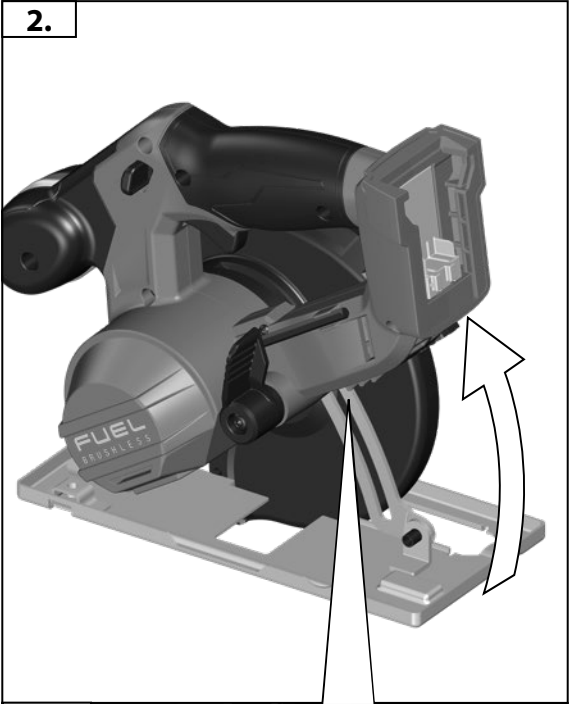
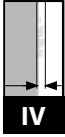
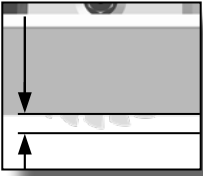

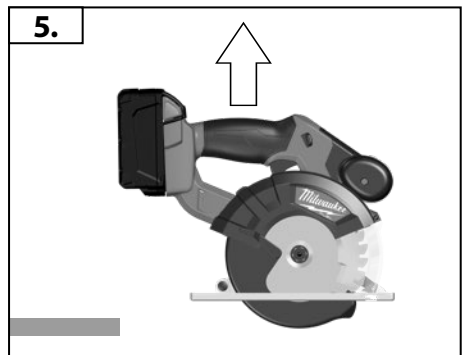
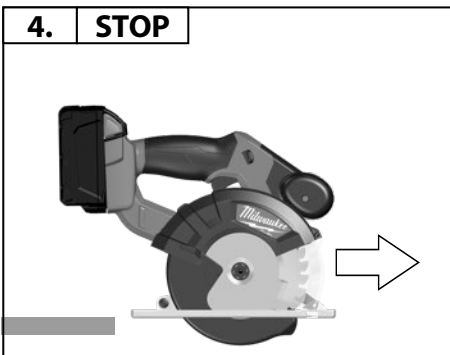
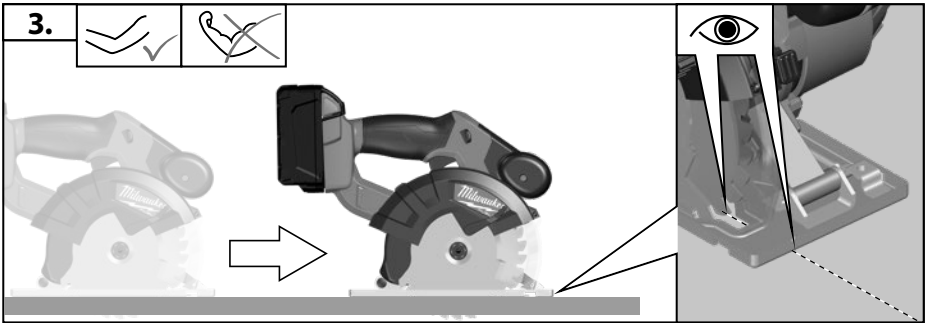
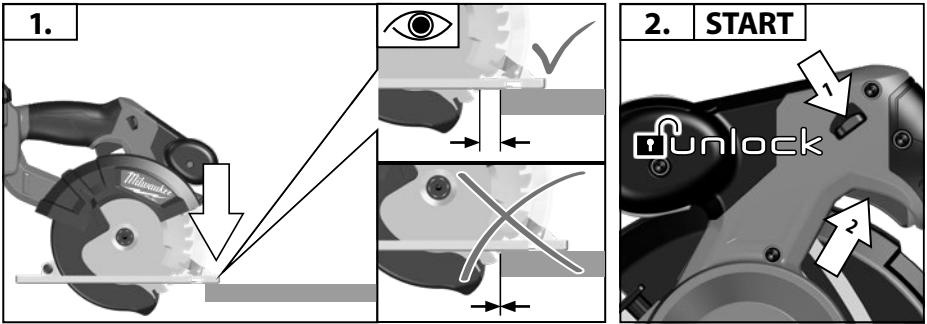
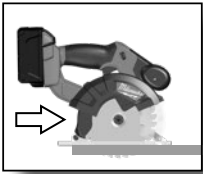

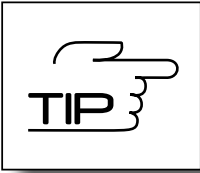

TIP
VI

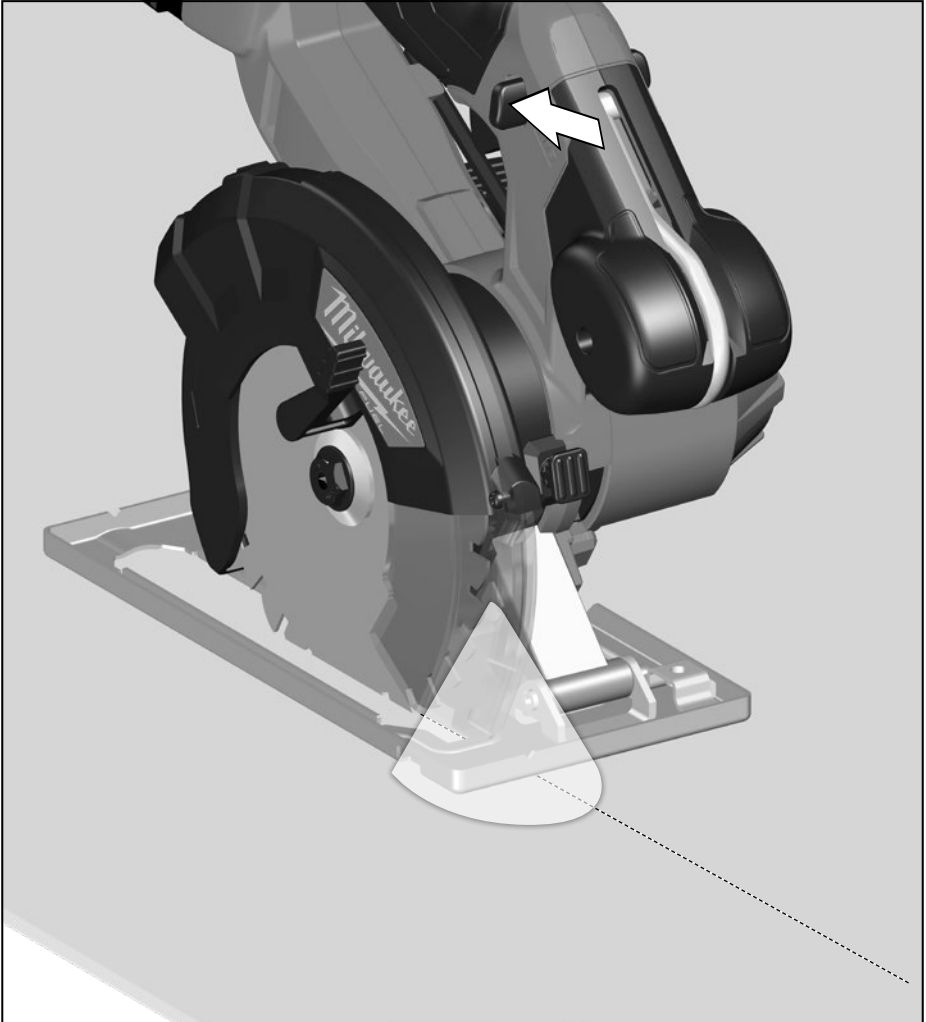

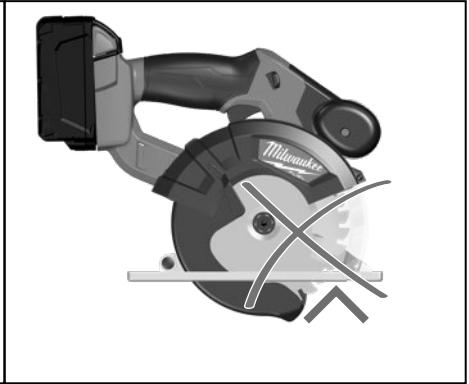
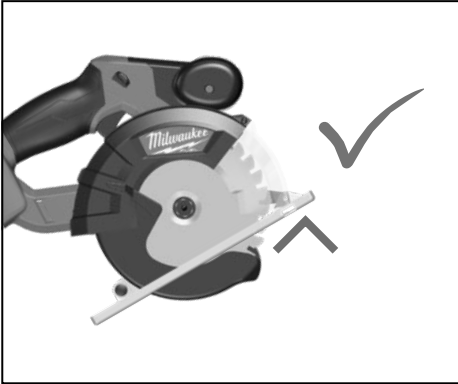
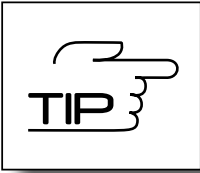

VI

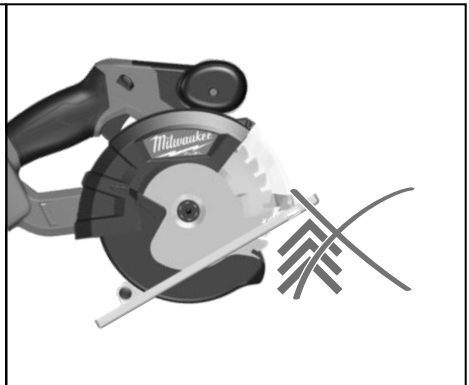
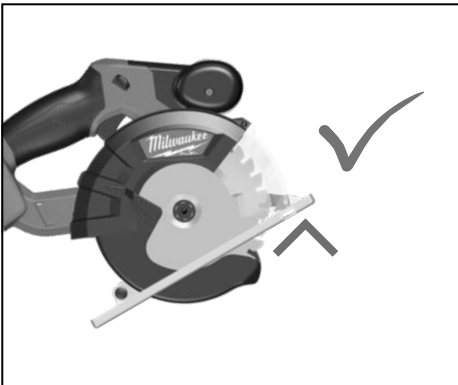

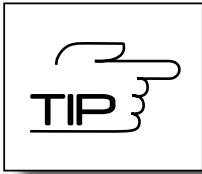

TIP
VI

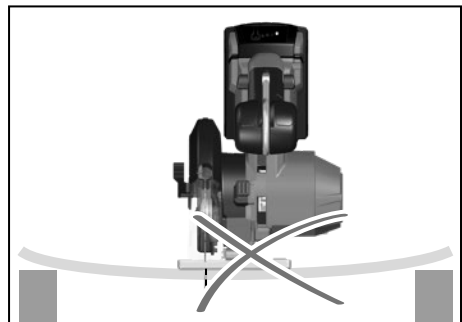
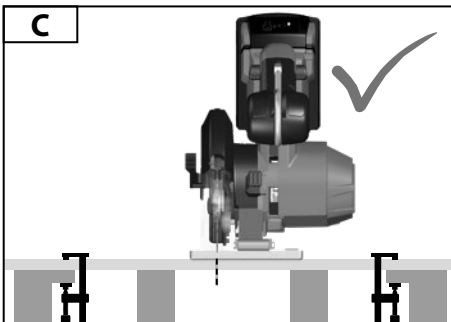
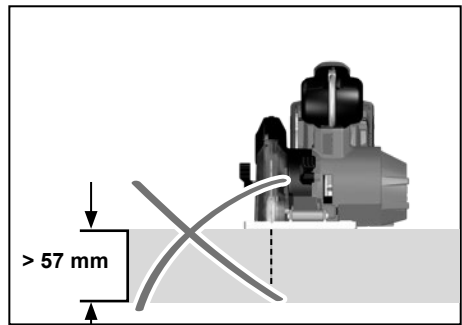
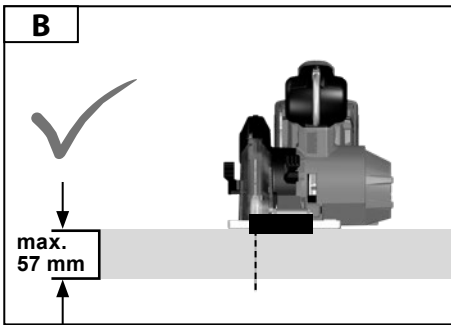
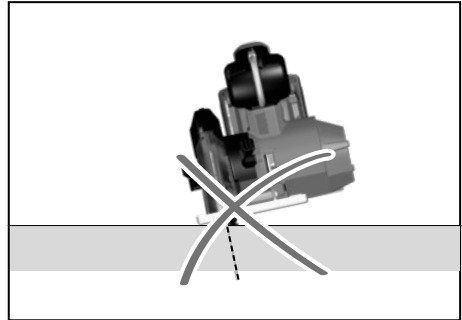
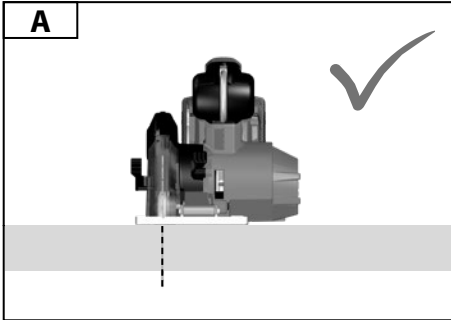

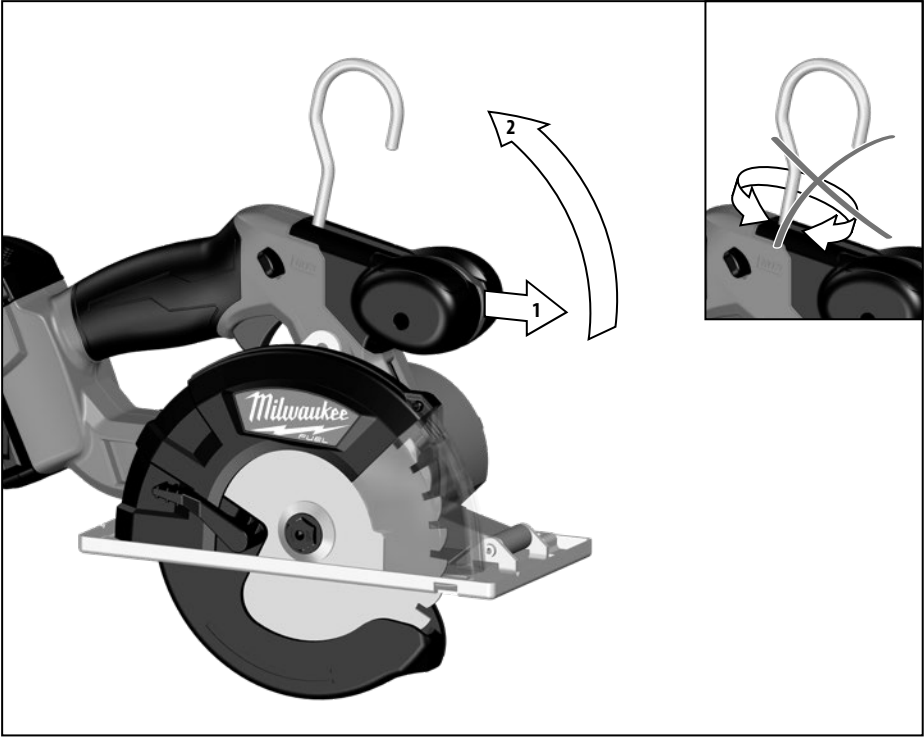
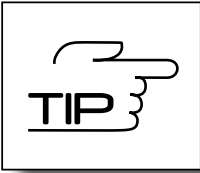

VI

TECHNICAL DATA	M18 FMCS
Metal saw	
Production code	4696 13 03 000001-999999
Battery voltage	18 V
No-load speed	3900 min ⁻¹
Saw blade dia. x hole dia	150 mm x 20 mm (5-7/8")
Saw blade thickness	1,3 mm
Blade teeth	34
Max. cutting capacity	
Steel	6,5 mm
Metal pipe Ø	57 mm
Sections max.	57 mm
Weight according EPTA-Procedure 01/2014 (Li-Ion 2,0 Ah ... 9,0 Ah)	2,5 ... 3,2 kg
Recommended Ambient Operating Temperature	-18°C ... +50°C
Recommended battery types	M18B...
Recommended charger	M12-18..., M1418 C6
Noise information	
Measured values determined according to EN 62841. Typically, the A-weighted noise levels of the tool are:	
Sound pressure level (Uncertainty K=3dB(A))	98,1 dB(A)
Sound power level (Uncertainty K=3dB(A))	109,1 dB(A)
Wear ear protectors!	
Vibration information	
Vibration total values (triaxial vector sum) determined according to EN 62841	
Cutting metal	
Vibration emission value a _{h,M}	2,37 m/s ²
Uncertainty K=	1,5 m/s ²



WARNING!

The vibration emission level given in this information sheet has been measured in accordance with a standardised test given in EN 62841 and may be used to compare one tool with another. It may be used for a preliminary assessment of exposure.

The declared vibration emission level represents the main applications of the tool. However if the tool is used for different applications, with different accessories or poorly maintained, the vibration emission may differ. This may significantly increase the exposure level over the total working period.

An estimation of the level of exposure to vibration should also take into account the times when the tool is switched off or when it is running but not actually doing the job. This may significantly reduce the exposure level over the total working period.

Identify additional safety measures to protect the operator from the effects of vibration such as: maintain the tool and the accessories, keep the hands warm, organisation of work patterns.

WARNING Read all safety warnings, instructions, illustrations and specifications provided with this power tool.

Failure to follow all instructions listed below may result in electric shock, fire and/or serious injury.

Save all warnings and instructions for future reference.

CIRCULAR SAW SAFETY WARNINGS

Cutting procedures

a)  **DANGER: Keep hands away from cutting area and the blade. Keep your second hand on auxiliary handle, or motor housing.** If both hands are holding the saw, they cannot be cut by the blade.

b) **Do not reach underneath the workpiece.** The guard cannot protect you from the blade below the workpiece.

c) **Adjust the cutting depth to the thickness of the workpiece.** Less than a full tooth of the blade teeth should be visible below the workpiece.

d) **Never hold the workpiece in your hands or across your leg while cutting. Secure the workpiece to a stable platform.** It is important to support the work properly to minimise body exposure, blade binding, or loss of control.

e) **Hold the power tool by insulated gripping surfaces only, when performing an operation where the cutting tool may contact hidden wiring or its own cord.** Contact with a "live" wire will also make exposed metal parts of the power tool "live" and could give the operator an electric shock.

f) **When ripping, always use a rip fence or straight edge guide.** This improves the accuracy of cut and reduces the chance of blade binding.

g) **Always use blades with correct size and shape (diamond versus round) of arbour holes.** Blades that do not match the mounting hardware of the saw will run off-centre, causing loss of control.

h) **Never use damaged or incorrect blade washers or bolt.** The blade washers and bolt were specially designed for your saw, for optimum performance and safety of operation.

Kickback causes and related warnings

– kickback is a sudden reaction to a pinched, jammed or misaligned saw blade, causing an uncontrolled saw to lift up and out of the workpiece toward the operator;

– when the blade is pinched or jammed tightly by the kerf closing down, the blade stalls and the motor reaction drives the unit rapidly back toward the operator;

– if the blade becomes twisted or misaligned in the cut, the teeth at the back edge of the blade can dig into the top surface of the wood causing the blade to climb out of the kerf and jump back toward the operator.

Kickback is the result of saw misuse and/or incorrect operating procedures or conditions and can be avoided by taking proper precautions as given below.

a) Maintain a firm grip with both hands on the saw and position your arms to resist kickback forces. Position your body to either side of the blade, but not in line with the blade. Kickback could cause the saw to jump backwards, but kickback forces can be controlled by the operator, if proper precautions are taken.

b) When blade is binding, or when interrupting a cut for any reason, release the trigger and hold the saw motionless in the material until the blade comes to a complete stop. Never attempt to remove the saw from the work or pull the saw backward while the blade is in motion or kickback may occur. Investigate and take corrective actions to eliminate the cause of blade binding.

c) When restarting a saw in the workpiece, centre the saw blade in the kerf so that the saw teeth are not engaged into the material. If a saw blade binds, it may walk up or kickback from the workpiece as the saw is restarted.

d) Support large panels to minimise the risk of blade pinching and kickback. Large panels tend to sag under their own weight. Supports must be placed under the panel on both sides, near the line of cut and near the edge of the panel.

e) Do not use dull or damaged blades. Unsharpened or improperly set blades produce narrow kerf causing excessive friction, blade binding and kickback.

f) Blade depth and bevel adjusting locking levers must be tight and secure before making the cut. If blade adjustment shifts while cutting, it may cause binding and kickback.

g) Use extra caution when sawing into existing walls or other blind areas. The protruding blade may cut objects that can cause kickback.

Lower guard function

a) Check the lower guard for proper closing before each use. Do not operate the saw if the lower guard does not move freely and close instantly. Never damp or tie the lower guard into the open position. If the saw is accidentally dropped, the lower guard may be bent. Raise the lower guard with the retracting handle and make sure it moves freely and does not touch the blade or any other part, in all angles and depths of cut.

b) Check the operation of the lower guard spring. If the guard and the spring are not operating properly, they must be serviced before use. Lower guard may operate sluggishly due to damaged parts, gummy deposits, or a build-up of debris.

c) The lower guard may be retracted manually only for special cuts such as "plunge cuts" and "compound cuts". Raise the lower guard by the retracting handle and as soon as the blade enters the material, the lower guard must be released. For all other sawing, the lower guard should operate automatically. NOTE Alternate wording for "retracting handle" is possible.

d) Always observe that the lower guard is covering the blade before placing the saw down on bench or floor. An unprotected, coasting blade will cause the saw to walk backwards, cutting whatever is in its path. Be aware of the time it takes for the blade to stop after switch is released.

Additional Safety and Working Instructions

Wear ear protectors. Exposure to noise can cause hearing loss.

Use protective equipment. Always wear safety glasses when working with the machine. The use of protective clothing is recommended, such as dust mask, protective gloves, sturdy non-slip footwear, helmet and ear defenders.

The dust produced when using this tool may be harmful to health. Do not inhale the dust. Wear a suitable dust protection mask.

Do not use saw blades not corresponding to the key data given in these instructions for use.

It is necessary to select a saw blade which is suitable for the material being cut.

The rated speed of the accessory must be at least equal to the maximum speed marked on the power tool.

Do not use abrasion disks in this machine!

Do not fix the on/off switch in the "on" position when using the saw hand-held.

Adapt the feed speed to avoid overheating the blade tips.

Use only System M18 chargers for charging System M18 battery packs. Do not use battery packs from other systems.

Never break open battery packs and chargers and store only in dry rooms. Keep dry at all times.

WARNING! To reduce the risk of fire, personal injury, and product damage due to a short circuit, never immerse your tool, battery pack or charger in fluid or allow a fluid to flow inside them. Corrosive or conductive fluids, such as seawater, certain industrial chemicals, and bleach or bleach containing products, etc., Can cause a short circuit.

ELECTRIC BRAKE

The electric brake engages when the trigger is released, causing the blade to stop and allowing you to proceed with your work. Generally, the saw blade stops within 3 seconds.

However, there may be a delay between the time you release the trigger and when the brake engages. At a power interruption and still switched on machine, the braking function is not available.

You must always wait for the blade to stop completely before removing the saw from the workpiece.

SPECIFIED CONDITIONS OF USE

The Metal Saw may be used to cut lengthways and mitre a variety of metals, such as metal profiles (UniStrut), pipes, metal studs, channels, aluminium profiles, metal sheets, etc.



BATTERIES

Battery packs which have not been used for some time should be recharged before use.

Temperatures in excess of 50°C (122°F) reduce the performance of the battery pack. Avoid extended exposure to heat or sunshine (risk of overheating).

The contacts of chargers and battery packs must be kept clean.

For an optimum life-time, the battery packs have to be fully charged, after use. Battery packs which have not been used for some time should be recharged before use.

To obtain the longest possible battery life remove the battery pack from the charger once it is fully charged.

For battery pack storage longer than 30 days: Store the battery pack where the temperature is below 27°C and away from moisture. Store the battery packs in a 30% - 50% charged condition. Every six months of storage, charge the pack as normal.

Do not dispose of used battery packs in the household refuse or by burning them. Milwaukee Distributors offer to retrieve old batteries to protect our environment.

Do not store the battery pack together with metal objects (short circuit risk).

Never break open battery packs and chargers and store only in dry rooms. Keep dry at all times.

Battery acid may leak from damaged batteries under extreme load or extreme temperatures. In case of contact with battery acid wash it off immediately with soap and water. In case of eye contact rinse thoroughly for at least 10 minutes and immediately seek medical attention.

No metal parts must be allowed to enter the battery section of the charger (short circuit risk).

TRANSPORTING LITHIUM BATTERIES

Lithium-ion batteries are subject to the Dangerous Goods Legislation requirements.

Transportation of those batteries has to be done in accordance with local, national and international provisions and regulations.

The user can transport the batteries by road without further requirements.

Commercial transport of Lithium-Ion batteries by third parties is subject to Dangerous Goods regulations. Transport preparation and transport are exclusively to be carried out by appropriately trained persons and the process has to be accompanied by corresponding experts.

When transporting batteries:

Ensure that battery contact terminals are protected and insulated to prevent short circuit. Ensure that battery pack is secured against movement within packaging. Do not transport batteries that are cracked or leak. Check with forwarding company for further advice

MAINTENANCE

Remove the battery pack before starting any work on the appliance.

Be sure to disconnect the tool from the power supply before attaching or removing the saw blade.

Clean tool and guarding system with dry cloth. Certain cleaning agents and solvents are harmful to plastics and other insulated parts.

The ventilation slots of the machine must be kept clear at all times.

Remove dust regularly. Remove the sawdust which has accumulated inside the saw in order to avoid the risk of fire.

Keep the apparatus handle clean, dry and free of spilt oil or grease.

Check the function of guards.

Regular maintenance and cleaning provide for a long service life and safe handling.

If the supply cord of this power tool is damaged, it must be replaced by a specially prepared cord available through the service organization.

Use only Milwaukee accessories and Milwaukee spare parts. Should components need to be replaced which have not been described, please contact one of our Milwaukee service agents (see our list of guarantee/service addresses).

If needed, an exploded view of the tool can be ordered. Please state the Article No. as well as the machine type printed on the label and order the drawing at your local service agents or directly at: Techtronic Industries GmbH, Max-Eyth-Straße 10, 71364 Winnenden, Germany.

EC-DECLARATION OF CONFORMITY

We declare under our sole responsibility that the product described under "Technical Data" fulfills all the relevant provisions of the directives

2011/65/EU (RoHS)

2006/42/EC

2014/30/EU

and the following harmonized standards have been used.

EN 62841-1:2015

EN 62841-2-5:2014

EN 55014-1:2017+A11:2020

EN 55014-2:2015

EN IEC 63000:2018



Winnenden, 2020-11-11

Alexander Krug / Managing Director
Authorized to compile the technical file

Techtronic Industries GmbH
Max-Eyth-Straße 10, 71364 Winnenden, Germany

GB-DECLARATION OF CONFORMITY

We declare as the manufacturer under our sole responsibility that the product described under „Technical Data“ fulfills all the relevant provisions of the following Regulations
S.I. 2012/3032 (as amended), S.I. 2008/1597 (as amended),
S.I. 2016/1091 (as amended) and that the following designated standards have been used:

BS EN 62841-1:2015
BS EN 62841-2-5:2014
BS EN 55014-1:2017+A11:2020
BS EN 55014-2:2015
BS EN IEC 63000:2018

Winnenden, 2020-11-11



Alexander Krug / Managing Director
Authorized to compile the technical file

Techtronic Industries GmbH
Max-Eyth-Straße 10, 71364 Winnenden, Germany



SYMBOLS



CAUTION! WARNING! DANGER!



Please read the instructions carefully before starting the machine.



Always wear goggles when using the machine.



Remove the battery pack before starting any work on the appliance.



Accessory - Not included in standard equipment, available as an accessory.



Do not dispose electric tools, batteries/rechargeable batteries together with household waste material. Electric tools and batteries that have reached the end of their life must be collected separately and returned to an environmentally compatible recycling facility. Check with your local authority or retailer for recycling advice and collection point.

n₀ No-load speed

V Volts

 Direct Current

 European Conformity Mark

 British Conformity Mark

 Ukraine Conformity Mark

 EurAsian Conformity Mark

Copyright 2020
Techtronic Industries GmbH
Max-Eyth-Straße 10
71364 Winnenden
Germany
+49 (0) 7195-12-0
www.milwaukeeetool.eu

Techtronic Industries (UK) Ltd
Fieldhouse Lane
Marlow Bucks SL7 1HZ
UK



**EAC UK
CA**

(11.20)

4100 4252 32