

# TITAN

## Wet/Dry Vacuum Cleaner 1500 W

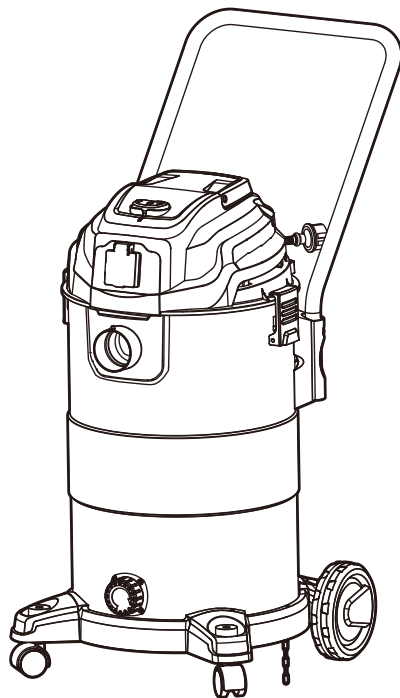

### TTB777VAC

EAN: 5059340106229

WARNING: Read the instructions before using the product!



# TITAN

**Congratulations on your purchase of a TITAN power tool from Kingfisher International Products B.V.. We want you to continue getting the best performance from it so this handbook includes information on safety, handling and care. Please retain this handbook in case you need to refer to any of the information in the future. Your TITAN power tool comes with a 2 year guarantee, so should it develop a fault within this period contact your retailer.**



## GUARANTEE

This TITAN product carries a 2 year guarantee. If your product develops a fault within this period, you should, in the first instance contact the retailer where the item was purchased. This guarantee specifically excludes losses caused due to:

- Fair wear and tear
- Misuse or abuse
- Lack of routine maintenance
- Failure of consumable items (such as batteries)
- Accidental damage
- Cosmetic damage
- Failure to follow manufacturer's guidelines
- Loss of use of the goods

This guarantee does not affect your statutory rights. This guarantee is only valid in the UK.

# Let's get started...

These instructions are for your safety. Please read through them thoroughly before use and retain them for future reference.



## Getting **started**...

03

Safety information

04

**Your product**

14

Technical specifications

15

**Before you start**

16



## **In more detail**

26

**Product functions**

27

Operation

30

**Care and maintenance**

34

Troubleshooting

38

**Recycling and disposal**

39

## Safety warnings

---

### **IMPORTANT SAFETY INSTRUCTIONS READ CAREFULLY AND KEEP FOR FUTURE REFERENCE!**

- > This appliance can be used by children aged from 8 years and above and persons with reduced physical, sensory or mental capabilities or lack of experience and knowledge if they have been given supervision or instruction concerning use of the appliance in a safe way and understand the hazards involved. Children shall not play with the appliance. Cleaning and user maintenance shall not be made by children without supervision.
- > If the supply cord is damaged, it must be replaced by the manufacturer, its service agent or similarly qualified persons in order to avoid a hazard.
- > Before vacuuming, remove any large, sharp or sharpedged objects to avoid damage to the dust bag, filters and / or product.
- > Do not vacuum any hot or incandescent objects, liquids, chemicals or flammable materials.
- > Do not use the product without fitting a filter and / or dust bag first.
- > Carry, pull and push the product only by the handle, not by the hose or power cord.
- > Lay out the cord in such a way that no unintentional pulling or tripping over is possible.
- > Do not attempt to modify the product in any way.
- > Only use attachments and accessories recommended by the manufacturer.
- > Never use the product to vacuum up flammable or

- combustible liquids, such as gasoline, photocopier powder or volatile substances; and do not use the product in areas where these liquids are present. Do not vacuum up acids.
- > Do not vacuum up any objects which are toxic, cancer causing, combustible, or any other dangerous materials, such as asbestos, asbestos dust, arsenic, barium, beryllium, lead, pesticides, or any other substances hazardous to health.
  - > DANGER OF FIRE! Never vacuum up any objects which are burning or smoldering, such as cigarettes, cigarette butts, matches, or hot ashes.
  - > WARNING! Operators shall be adequately instructed on the use of this product!
  - > WARNING! The product is not suitable for picking up hazardous dust!
  - > CAUTION! This product is for indoor use only!
  - > CAUTION! This product shall be stored indoors only!
  - > WARNING! Switch the product off and disconnect it from power supply by pulling the plug before cleaning, maintaining, replacing attachments / accessories or converting to another function!
  - > The plug must be removed from the socket-outlet before cleaning or maintaining the appliance.

## **Blower safety warnings**

### Training

- > Read the instructions carefully. Be familiar with the controls and the proper use of the product.
- > Never allow people unfamiliar with these instructions to use the product. Local regulations may restrict the age

of the operator.

- > The operator or user is responsible for accidents or hazards occurring to other people or their property.

## Preparation

- > Obtain ear protection and safety glasses. Wear them at all times while operating the product.
- > While operating the product always wear substantial footwear and long trousers. Do not operate the product when barefoot or wearing open sandals. Avoid wearing clothing that is loose fitting or that has hanging cords or ties.
- > Do not wear loose clothing or jewellery that can be drawn into the air inlet. Keep long hair away from the air inlets.
- > Operate the product in a recommended position and only on a firm, level surface.
- > Do not operate the product on a paved or gravel surface where blown material could cause injury.
- > Before using, always visually inspect to see that the bolts and other fasteners are secure and the housing is undamaged. Replace worn or damaged components in sets to preserve balance. Replace damaged or unreadable labels.
- > Never operate the product while people, especially children or pets are nearby.
- > To prevent dust irritation the wearing of a face mask is recommended.

## Operation

- > Keep proper balance and footing at all times. Do not overreach.

- > If the product should start making any unusual noise or vibration, immediately shut off the power source and allow the product to stop. Disconnect the product from the supply and take the following steps before restarting and operating the product:
  - inspect for damage;
  - replace or repair any damaged parts;
  - check for and tighten any loose parts.
- > Keep the power source clean of debris and other accumulations to prevent damage to the power source or possible fire.
- > Do not transport this product while the power source is running.
- > Stop the product, shut off the power source and disconnect the product from the supply. Make sure that all moving parts have come to a complete stop
  - whenever you leave the product,
  - before clearing blockages or unclogging chute,
  - before checking, cleaning or working on the product,
- > Do not tilt the product while the power source is running.
- > Walk, never run.
- > Operate the product only in daylight or in good artificial light.
- > Do not blow hard objects such as nails, bolts, or rocks.
- > Apply extra care when cleaning debris from stairs or other tight areas.

**Follow below recommendations when using the product:**

- > Use rakes and brooms to loosen debris before blowing/vacuuming.

- > Slightly dampen surfaces in dust conditions or use mister attachment.

## Electrical safety

- > Ensure the rated voltage shown on the rating label corresponds with the voltage of the power supply.
- > Do not operate any product with a damaged power cord or plug, when the product malfunctions or has been damaged in any manner.
- > Protect the power cord against damage. Do not let it hang over sharp edges; do not squeeze or bend it. Keep the power cord away from hot surfaces and ensure that nobody can trip over it.
- > Do not insert fingers or foreign objects in any opening of the product and do not obstruct the air vents.
- > Protect the product against heat. Do not place close to heat sources such as stoves or heating appliances.

## Emergency

**Familiarise yourself with the use of this product by means of this instruction manual. Memorise the safety warnings and follow them to the letter. This will help to prevent risks and hazards.**

- > Always be alert when using this product, so that you can recognise and handle risks early. Fast intervention can prevent serious injury and damage to property.
- > Switch off and disconnect from the power supply if there are malfunctions. Have the product checked by a qualified professional and repaired, if necessary, before you operate it again.



## Residual risks

**Even if you are operating this product in accordance with all the safety requirements, potential risks of injury and damage remain. The following dangers can arise in connection with the structure and design of this product:**

- > Health defects resulting from vibration emission if the product is being used over long periods of time or not adequately managed and properly maintained.
- > Injuries and damage to property due to broken accessories or the sudden impact of hidden objects during use.
- > Danger of injury and property damage caused by flying objects.

The following information applies to professional users only but is good practice for all users:

### Additional safety warnings for construction dust

The updated Control of Substances Hazardous to Health Regulations 1st October 2012 now also targets to reduce the risks associated with silica, wood and gypsum dusts.

Construction workers are one of the at-risk groups within this because of the dust that they breathe: silica dust is not just a nuisance; it is a real risk to your lungs!

Silica is a natural mineral present in large amounts in things like sand, sandstone and granite. It is also commonly found in many construction materials such as concrete and mortar. The silica is broken into very fine dust (also known as Respirable Crystalline Silica or RCS) during many common tasks such as cutting, drilling and

grinding Breathing in very fine particles of crystalline silica can lead to the development of:

Lung cancer Silicosis Chronic Obstructive Pulmonary Disorder (Chronic obstructive pulmonary disease (COPD)) And breathing in fine particles of wood dust can lead to the development of Asthma The risk of lung disease is linked to people who regularly breathe construction dust over a period of time, not on the odd occasion.

To protect the lung, the COSHH Regulations sets a limit on the amount of these dusts that you can breathe (called a Workplace Exposure Limit or WEL) when averaged over a normal working day. These limits are not a large amount of dust: when compared to a penny it is tiny – like a small pinch of salt:

This limit is the legal maximum; the most you can breathe after the right controls have been used.

How to reduce the amount of dust?

- > Reduce the amount of cutting by using the best sizes of building products.
- > Use a less powerful tool e.g. a block cutter instead of angle grinder.
- > Using a different method of work altogether – e. g. using a nail gun to direct fasten cable trays instead of drilling holes first.

Please always work with approved safety equipment, such as those dust masks that specially designed to filter out microscopic particles and use the dust extraction facility at all time.

For more information, please see the HSE website:

<http://www.hse.gov.uk/construction> or <http://www.hse.gov.uk/pubns/cis69.pdf>



**WARNING!** Some dust created by power sanding, sawing, grinding, drilling and other construction activities contains chemicals known to cause cancer, birth defects or other reproductive harm.

Some examples of these chemicals are:

- Lead from lead-based paint
- Crystalline silica from bricks and cement and other masonry products
- Arsenic and chromium from chemically treated timber

Your risk from these exposures varies, depending upon how often you do this type of work. To reduce your exposure to these chemicals:

- Work in a well-ventilated area.
- Work with approved protective equipment, such as those dust masks that are specially designed to filter microscopic particles.

## Symbols

On the product, the rating label and within these instructions you will find among others the following symbols and abbreviations. Familiarise yourself with them to reduce hazards like personal injuries and damage to property.

V~	Volt (alternating voltage)	kg	Kilogram
Hz	Hertz	kPa	Kilopascal
W	Watt	dB(A)	Decibel (A-rated)
mm	Millimetre	m/s <sup>2</sup>	Metres per second squared
L	Litre		

IPX4 Protection against penetration of dust, protection against vertical water drips.



Lock / to tighten or secure.



Unlock / to loosen.



Note / Remark.



Caution / Warning.



Read the instruction manual.



Wear eye protection



Wear a dust mask.



Wear hearing protection.



Wear protective gloves.



Wear face protection.



Wear tight-fitted protective clothes.



Beware of electric voltage!



Only use in dry indoor rooms.

yyWxx

Manufacturing date code; year of manufacturing (20yy) and week of manufacturing (Wxx).



Switch the product off and disconnect it from the power supply before assembly, cleaning, adjustments, maintenance, storage and transportation.



Dry



Wet or damp



Blowing



Keep bystanders away!



Objects thrown by the product could hit the user or other bystanders. Always ensure that other people and pets remain at a safe distance from the product when it is in operation. In general, children must not come near the area where the product is.



The product complies with the applicable European directives and an evaluation method of conformity for these directives was done.



WEEE symbol. Waste electrical products should not be disposed of with household waste. Please recycle where facilities exist. Check with your Local Authority or local store for recycling advice.

## RATING LABEL EXPLANATION

**TTB777VAC**

**TT** = TITAN

**B** = 240V AC

**777** = Model Number

**VAC** = Vacuum Cleaner

## Your product

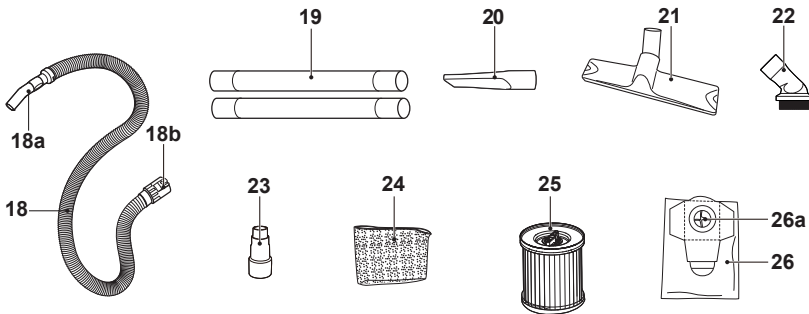
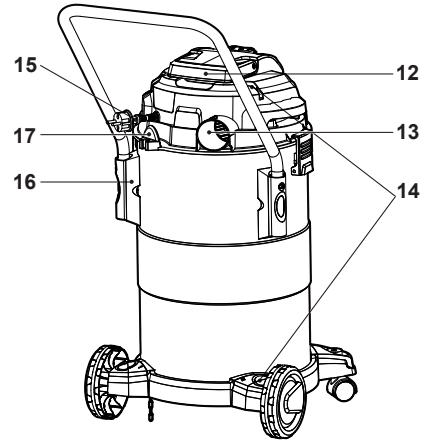
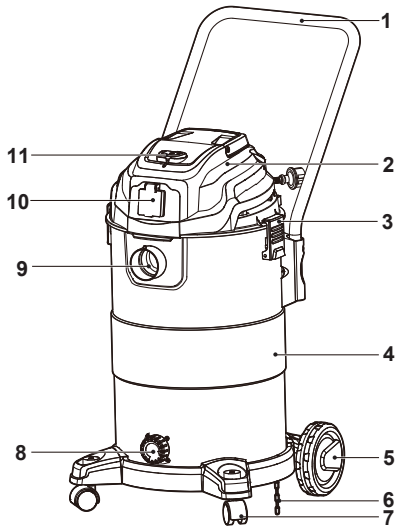

1. Push/Pull handle
2. Motor unit
  - a. Safety valve\*
3. Plastic clasp (x 2)
4. Tank
5. Rear wheel (x 2)
  - a. Screw\* (x 2)
6. Anti-static chain
7. Castor (x 2)
  - a. Screw\* (x 2)
8. Drainage port
  - a. Drain cap
9. Air inlet
10. Synchro socket
11. On / Off switch
12. Transportation handle
13. Air outlet
14. Attachment storage
15. Power cord
16. Handle sockets (x 2)
  - a. PVC washer\* (x 2)
  - b. Rubber washer\* (x 4)
  - c. Washer\* (x 4)
  - d. Screw\* (x 4)
17. Hook (for cord storage)
18. Hose
  - a. Hose handle\*
  - b. Hose connector\*
19. Extension tube (x2)
20. Crevice nozzle
21. Brush with rubber/bristle blade
22. Round dust brush
23. Power tool hose adaptor
24. Foam sleeve
25. Cartridge filter
26. Dust bag
  - a. Opening\*



**NOTE:** Parts marked with \* are not shown in this overview. Please refer to the respective section in the instruction manual.

## Technical specifications

> Rated voltage, frequency	: 220 - 240 V~, 50/60 Hz
> Rated power input	: 1500 W
> Maximum wattage from synchro socket	: 1620 W
> Vacuum pressure	: Max 20kPa
> Tank volume	: 40 L
> Degree of protection	: IPX4
> Protection class	: Class I
> Net weight	: 9.16 kg
> Dimensions	: 36 x 35 x 88.6 cm

## Unpacking

Unpack all parts and lay them on a flat, stable surface.

- > Remove all packing materials and shipping devices, if applicable.
- > Make sure the delivery contents are complete and free of any damage. If you find that parts are missing or show damage do not use the product but contact your dealer. Using an incomplete or damaged product represents a hazard to people and property.
- > Ensure that you have all the accessories and tools needed for assembly and operation. This also includes suitable personal protective equipment.



**WARNING!** The product and the packaging are not children's toys! Children must not play with plastic bags, sheets and small parts! There is a danger of choking and suffocation!

## You will need

### (items not supplied)

Suitable personal protective equipment  
Suitable crosshead screwdriver

### (items supplied)

Hose (18)  
Extension tube (x 2) (19)  
Crevice nozzle (20)  
Brush with rubber/bristle blade (21)  
Round dust brush (22)  
Power Tool Hose Adaptor (23)  
Foam sleeve (24)  
Cartridge filter (25)  
Dust bag (26)

## Accessories

A choice of accessories and attachments are supplied with this product. These are stored inside the product and need to be removed before assembly.

- > Unlock the clasps (3) and disassemble the motor unit (2) and tank (4) (Fig. 1).
- > Take the accessories / attachments out of the tank.
- > Check all components for damage and wear before assembly and operation.

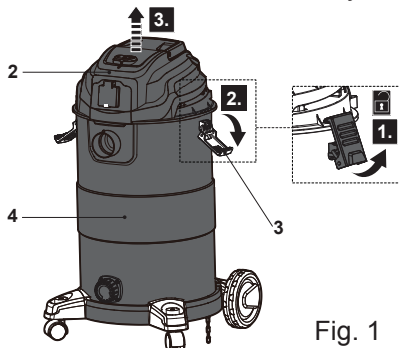



















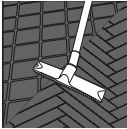











Fig. 1



Illustration	Description	Possible application
	Push/Pull handle (1)	/
	Rear Wheel (5)	/
	Castor (7)	/
	Hose (18)  	Connect the hose (18) to the air inlet / outlet (9, 13).
	Hose handle (18a)  	Connect attachments / accessories onto the hose handle (18a).
	Extension tube (19)  	Connect onto the hose handle (18a) with other attachments / accessories.
	Crevice nozzle (20)  	Crevices, corners, cracks and other places hard to reach. 
	Brush with rubber/bristle blade (21) 	Rugs, carpets, car seats and floors. 
	Brush with rubber/bristle blade (21) 	Tiles, wooden floors, linoleum. 
	Round dust brush (22) 	Furniture.
	Power tool hose adaptor (23)	Connect onto the hose handle (18a) with tool during synchro socket operation.
	Foam sleeve (24) 	Prevent liquid mist entering the motor.

	Cartridge filter (25) 	Filter finer particles to protect the motor (2).
	Dust bag (26) 	Collect debris and large dust particles.

## Assembly



**WARNING!** The product must be fully assembled before operation! Do not use a product that is only partly assembled or assembled with damaged parts!



Follow the assembly instructions step-by-step and use the pictures provided as a visual guide to easily assemble the product! Do not connect the product to power supply before it is completely assembled!



**NOTE:** Take care of small parts that are removed during assembly or when making adjustments. Keep them secure to avoid loss.

### Tank

- > Place the tank (4) upside down on a flat, stable surface.
- > Align and slide the castors (7) onto the wheel supports. Secure the connection with the screws (7a), using a suitable crosshead screwdriver (Fig. 2).

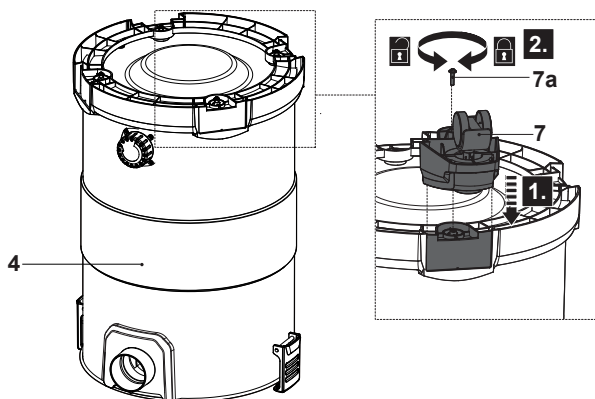

Fig. 2

- > Align and slide the rear wheels (5) onto the supports. The rear wheels and the vacuum base are marked with the numbers 1 and 2. Insert wheel 1 into slot 1 on the back of the vacuum; insert wheel 2 into slot 2 on the back of the vacuum. Secure the connection with the screws (5a), using a suitable crosshead screwdriver (Fig. 3 & 4).
- > Turn the assembled main body with the castors (7) and rear wheels (5) right way up and place it on a flat, stable surface. Ensure that castors rotate smoothly.

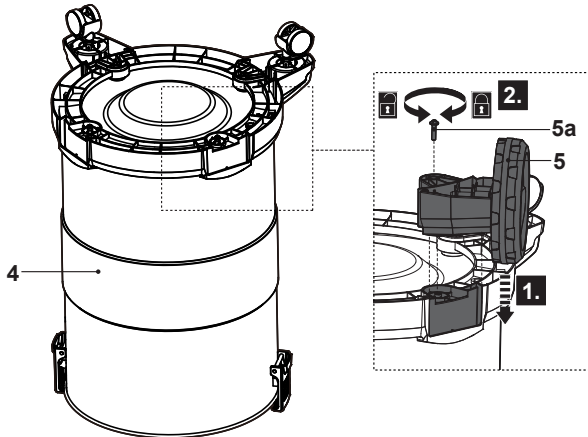

Fig. 3

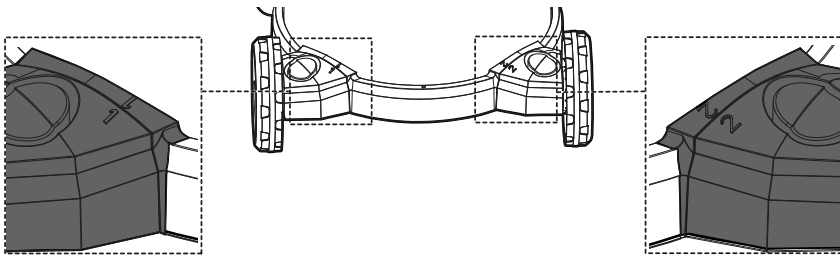

Fig. 4

### Push/Pull handle

- > Align the screw holes on the handle sockets (16), PVC washers (16a), rubber washers (16b) and washers (16c) with the screw holes on the tank (4). Secure the connection with the screws (16d) clockwise (Fig. 5).

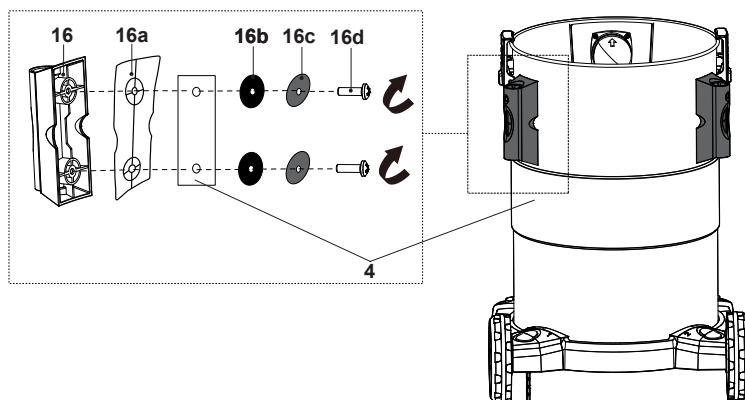

Fig. 5

- > Insert the push/pull handle (1) into the handle sockets (2) mounted on either side of the collection tank. Push down until the lock pins click in place (Fig. 6).

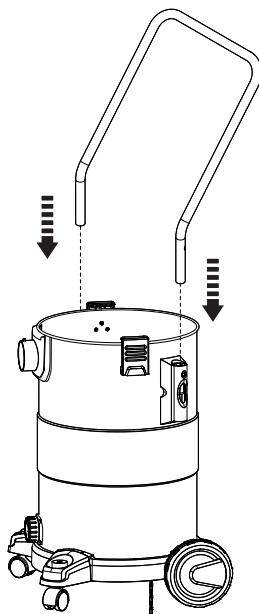

Fig. 6



## Product configurations

This product is designed for dry and wet vacuuming as well as blowing. Assemble the accessories and attachments according to the desired operation.



**NOTE:** Always use the product:

- with cartridge filter (25) and dust bag (26) assembled for dry vacuuming and blowing (Fig. 7)
- with foam sleeve (24) for wet vacuuming (Fig. 8).

Operation	Dry vacuuming 	Blowing 	Wet vacuuming 
<b>Parts</b>			
Motor unit (2)	•	•	•
Tank (4)	•	•	•
Hose (18)	•	•	•
Foam sleeve (24)			•
Dust filter (25)	•	•	
Dust bag (26)	•	•	

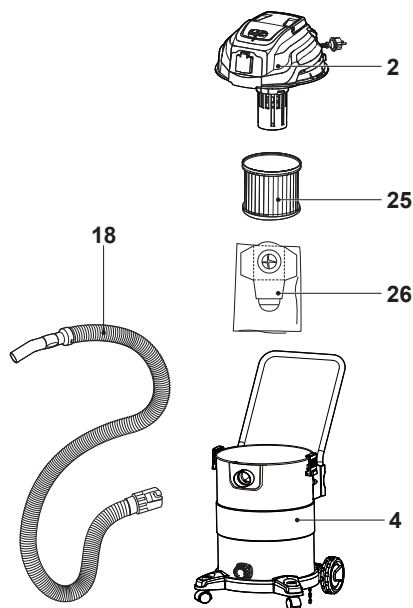

Fig. 7 Dry vacuuming and blowing

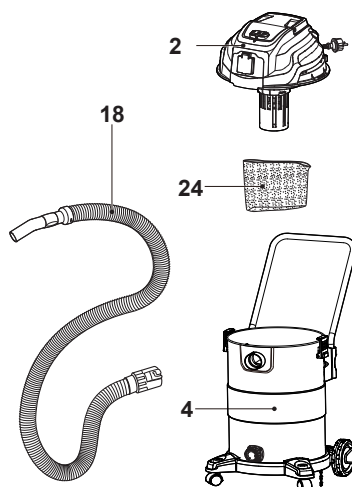

Fig. 8 Wet vacuuming

### Dust collection and blowing

- > Place the dust bag (26) into the tank (4). Ensure the dust bag opening (26a) is located on top.
- > Hold the side flaps of the dust bag opening (26a) and slide the dust bag opening (26a) onto the inner opening of the air inlet (9) (Fig. 9). Ensure the connection is properly sealed.
- > Assemble the dust filter (25) onto the motor unit (2) (Fig. 10). Ensure the filter sits properly in position. Refer to Fig. 20.

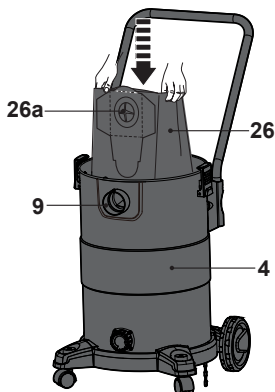

Fig. 9

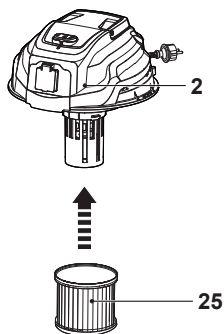

Fig. 10

- > Place the motor unit (2) with cartridge filter (25) onto the tank (4) and secure it with the clasps (3) (Fig. 11). Ensure the motor unit sits properly on the tank and the connection is properly sealed.

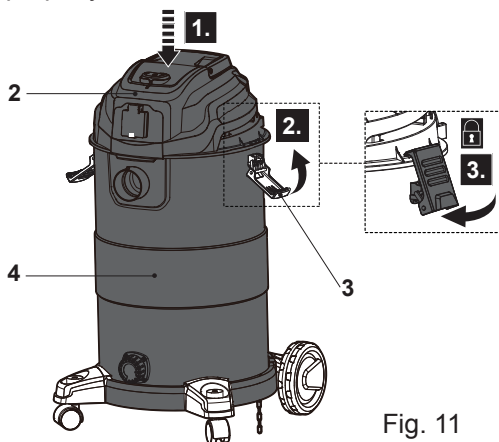

Fig. 11

## Liquid collection



**NOTE:** Always ensure the cartridge filter (25) and dust bag (26) are NOT used for wet vacuuming.

- > Slide the foam sleeve (24) onto the motor unit (2) (Fig. 12). Ensure it sits properly in position. Refer to Fig. 21.
- > Place the motor unit (2) with foam sleeve (24) onto the tank (4) and secure it with the clasps (3) (Fig. 13). Ensure the motor unit sits properly on the tank and the connection is properly sealed.

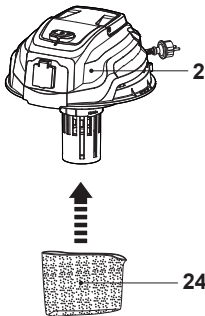

Fig. 12

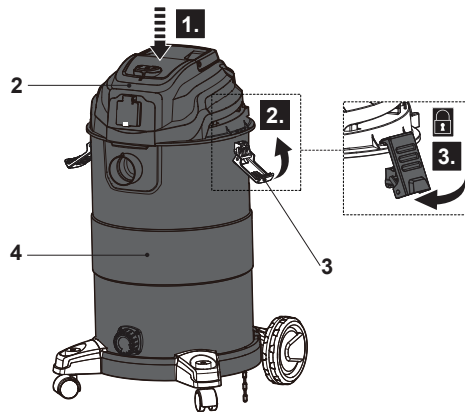

Fig. 13

## Hose (vacuuming)

- > Align the arrow on the hose connector (18b) with the tab on the outer opening of the air inlet (9) and slide the hose connector into the outer opening of the air inlet (Fig. 14, step 1).
- > Rotate the hose connector (18b) clockwise and ensure the connection is properly secured (Fig. 14, step 2).
- > Rotate the hose connector (18b) anticlockwise and pull it from the air inlet (9) to disconnect the hose (18) after use (Fig. 15).

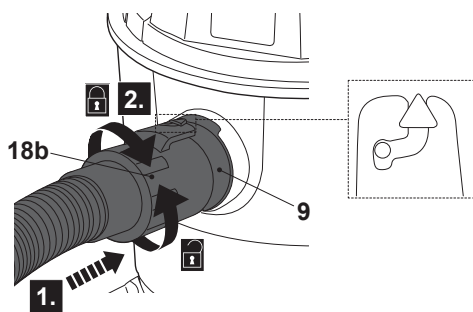

Fig. 14

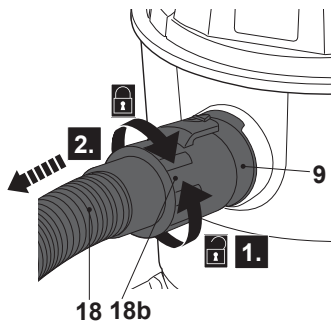

Fig. 15

### Hose (blowing)

- > Align the arrow on the hose connector (18b) with the tab on the outer opening of the air outlet (13) and slide the hose connector onto the air outlet (Fig. 16, step 1).
- > Rotate the hose connector (18b) clockwise and ensure the connection is properly secured (Fig. 16, step 2).

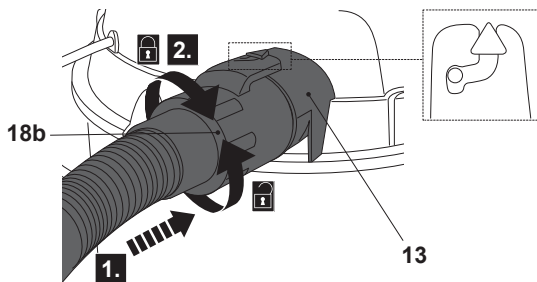

Fig. 16

- > Rotate the hose connector (18b) anticlockwise and pull it from the air outlet (13) to disconnect the hose (18) after use (Fig. 17).

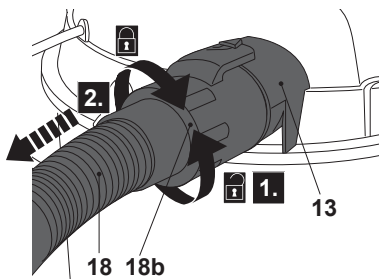

Fig. 17



## Accessories

- > Connect the extension tube(s) (19) and / or accessory (20, 21, 23) onto the hose handle (18a) if required (Fig. 18).

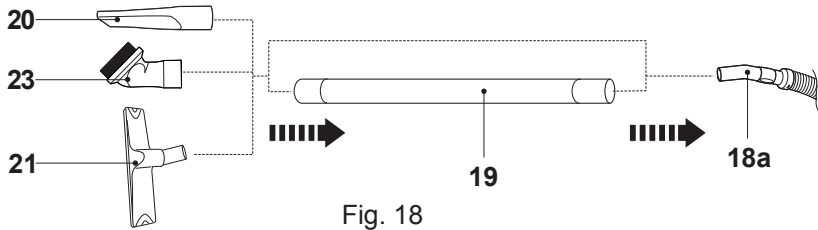

Fig. 18

- > Remove the respective attachment (20, 21, 23) and / or extension tube(s) (19) from the hose handle (18a) if necessary.

## Connection to power supply

- > Make sure the on / off switch (11) is in the off position O (Fig. 19).

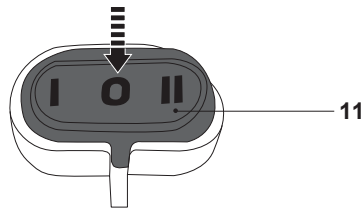

Fig. 19



**WARNING!** Check the voltage! The voltage must comply with the information on the rating label!

- > Unwind the power cord (9) and connect the plug with a suitable socket.
- > Your product is now ready to be used.



## In more detail...

<b>Product functions</b>	<b>27</b>
Operation	30
<b>Care and maintenance</b>	<b>34</b>
Troubleshooting	38
<b>Recycling and disposal</b>	<b>39</b>

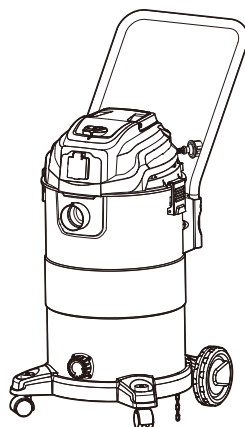

## Intended use

---

> This vacuum cleaner TTB777VAC is designated with a rated input of 1500 Watts. This product is intended for wet and dry vacuuming operations with respective attachments only. This product can also be used as an occasional blower.

As a vacuum cleaner:

- This product must not be used to vacuum up liquid other than water, especially flammable or combustible liquids, such as petrol, photocopier powder or volatile substances; and it is not suitable for operation in areas where these liquids are present. It is also not intended for vacuuming up acids.

As a blower:

- The product is intended for blowing dry leaves for piling up or removing material of hard to reach places.
- The product must not be used in areas where there is health damaging dust or as a wet blowing device.
- The product may only be used with the hose correctly installed. Avoid wet materials such as leaves and dirt, twigs, branches, pine needles, grass, earth, sand, mulch, cuttings etc. Do not use on wet lawns, grassy areas or fields.

For safety reasons it is essential to read the entire instruction manual before first operation and to observe all the instructions therein.

## Dust bag

---

Use the dust bag (26) to collect large dust particles and small debris.

Always assemble the dust bag (26) onto the tank (4) for dry vacuuming operations. Operating the product without the dust bag can create strong dust formation and/or damage the product.

- > Inspect the dust bag (26) regularly. Do not use it if you detect any damage.
- > Remove the dust bag (26) once full. We recommend replacing it when the product does not reach a sufficient suction power.



**NOTE:** A full dust bag reduces the performance of the product.

- > Fold the cardboard sides towards the centre of the opening (26a) to seal up the dust bag (26) and prevent dust and debris from spilling out.

## Cartridge filter (dry vacuuming and blowing)

Use the cartridge filter (25) to collect particles that are not already caught by the dust bag (26). Always assemble the cartridge filter (25) onto the motor unit (2) for dry vacuuming operations (Fig. 20). Operating the product without the cartridge filter (25) can damage the motor unit.

- > Inspect the cartridge filter (25) regularly. Replace it with a new one if necessary.
- > Wash the cartridge filter (25) frequently, with clear water and let it dry in air. Do not wait until the filter is completely dirty. We recommend inspecting the filter when the product does not reach a sufficient suction power.

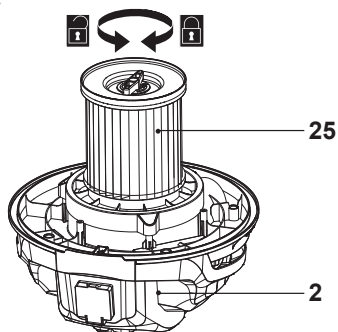

Fig. 20



**NOTE:** Do not use chemical, alkaline, abrasive or other aggressive detergents or disinfectants to clean the dust bag as they might be harmful to its surfaces/material.

## Foam sleeve (wet vacuuming)

Use the foam sleeve (24) during wet vacuuming operations (Fig. 21). Operating the product without the foam sleeve (24) can damage the motor unit.



**NOTE:** Do not use chemical, alkaline, abrasive or other aggressive detergents or disinfectants to clean the foam sleeve as they might be harmful to its surfaces/material.

- > Inspect the foam sleeve (24) regularly. Replace it with a new one if necessary.
- > Wash the foam sleeve (24) frequently, with clear water. Do not wait until the sleeve is completely dirty. We recommend inspecting the sleeve when the product does not reach a sufficient suction power.

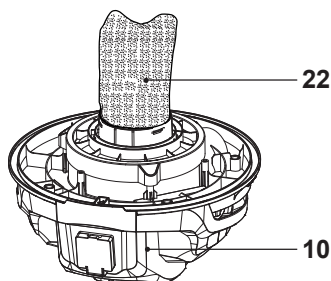

Fig. 21

## Safety valve

- > The product is designed with a safety valve (2a) to prevent water from entering into the motor unit (2) during wet vacuuming operations (Fig. 22). Before using, check that the safety valve moves freely within the cage.

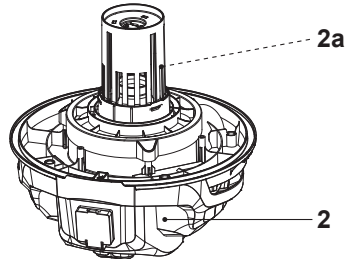

Fig. 22



**WARNING!** Always operate the product in an upright position to ensure the safety valve (2a) can prevent water from entering into the motor unit (2).



**WARNING!** Never attempt to remove the safety valve (2a) from the motor unit (2)! Using the product without the safety valve (2a) assembly can lead to malfunction or damage to the product as well as risk of injuries.

## Switching on / off

- > Press the on / off switch (11) to position I to switch the product on (Fig. 23).  
 > Press the on / off switch (11) to position O to switch the product off (Fig. 24).

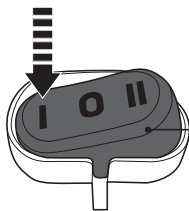

Fig. 23

11

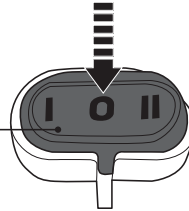

Fig. 24

## General operation

- > Check the product, its power cord and plug as well as accessories and attachments for damage before each use. Do not use the product if it is damaged or shows wear.
- > Double check that the accessories and attachments are properly fixed.
- > Ensure that the air vents / air outlet (13) are always unobstructed and clear. Clean them if necessary with a soft brush. Blocked air vents / air outlet may lead to overheating and damage the product.
- > Switch the product off immediately if you are disturbed while working by other people entering the working area.
- > Do not overwork yourself. Take regular breaks to ensure you can concentrate on the work and have full control over the product.



**NOTE:** Switch the product off and disconnect it from the power supply if it stops suddenly during operation and does not produce any suction. Refer to the instructions below about removing blockages and the chapter "Troubleshooting".

## Vacuating

This product is designed for dry and wet vacuuming. Each operation requires different accessories and attachments. Consult the section Product configurations for details.

- > Assemble the product according to the desired operation.
- > Attach the extension tube(s) (19) onto the hose handle (18a) if required.
- > Attach the desired attachment onto the hose handle / extension tube.
- > Switch the product on and hold the hose handle firmly.
- > Keep the attachment on the working surface in front of you.
- > Move in slight overlapping rows. The most effective pattern is straight lines along one of the sides. This will keep the rows even and ensures that the entire working surface is cleaned up without missing any spots (Fig. 25).

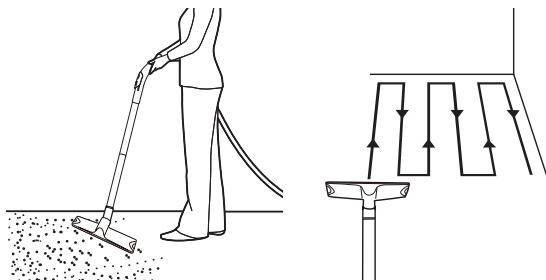

Fig. 25

## Wet vacuuming

- > During wet vacuuming, check the water level in the tank regularly. The water level should be below the air inlet (9) (Fig. 26). Empty the tank (4) regularly if large quantities of water are to be vacuumed.

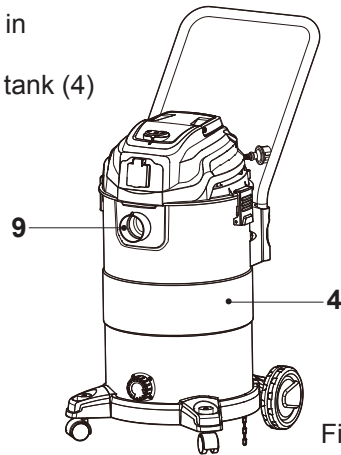

Fig. 26



**NOTE:** After wet vacuuming, turn the machine off and remove plug from power supply; remove the drain cap (8a) and drain the liquid into a suitable receptacle or drain (Fig. 27). Remember to refit the tank with the drain cap. Make sure the filters and tank are dry and clean before dry vacuuming.

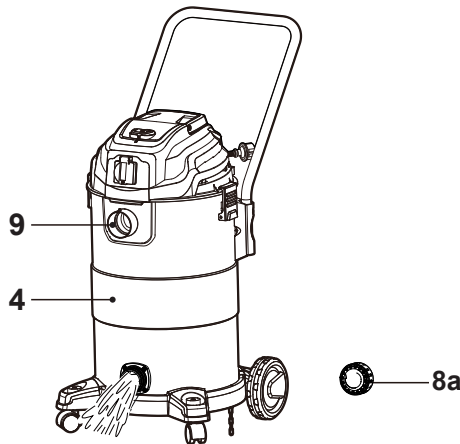

Fig. 27



**WARNING!** Do not overfill the tank (4) (max 30 litres)!

Do not fill with any other liquids than water as they might be harmful to the product attachments and surfaces.

## Blowing

This product is designed for light blowing. This operation requires some accessories and attachments. Consult the section Product configurations for details.

- > Before operation, loosen leaves that are stuck to the ground using a broom or rake.
- > Assemble the product according to the desired operation.
- > Attach the extension tube(s) (19) onto the hose handle (18a) if required.
- > Attach the desired attachment onto the hose handle / extension tube.
- > Switch the product on and hold the hose handle firmly.
- > Hold the hose approximately 10 cm above the ground and walk slowly forward using a sweeping motion from side to side (Fig. 28).
- > While working, ensure that the product does not strike hard objects, as this can cause damage.



Fig. 28

## Synchro socket operation

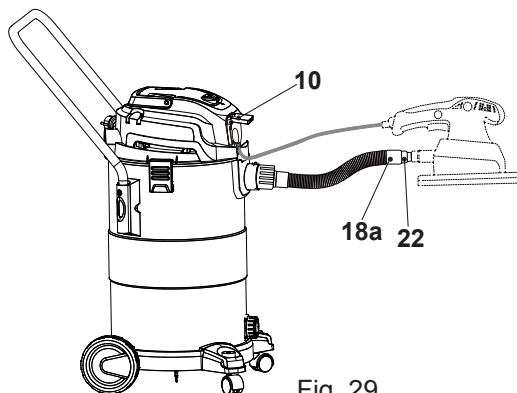

Fig. 29

Voltage	220-240 Volt 50/60Hz
Max Wattage from Motor	1500 W
Max Wattage from synchro socket	1620 W

This vacuum cleaner is equipped with a synchro socket (10) which allows a power tool (circular saw, drill, sanding machine, etc...) to be plugged directly into the vacuum synchro socket, and uses an automatic tool triggering feature for a clean work environment. For synchro socket operation, connect the power tool hose adaptor (22) onto the hose handle (18a) with other power tool (Fig. 29).





**WARNING! Do not plug any tool or appliance rated over the maximum wattage for the receptacle as noted in the chart above into the electrical socket on the vacuum cleaner.**

**Check nameplate of the tool for the wattage rating. To reduce the risk of injury, additional power tool must be turned (O) OFF before placing on/off switch (11) in the (II) AUTO position. (NEVER LEAVE THE UNIT RUNNING OR PLUGGED IN UNATTENDED).**

The power switch is used to select the automatic tool triggering feature built into the vacuum. With the (I) ON position selected, the vacuum will simply run continuously. When the (II) AUTO position is selected (Fig. 30), the vacuum will automatically turn on and off when the power tool is turned on and off.

For the auto tool triggering feature to work, the power tool must draw a minimum of 60 Watts.

The maximum wattage rating for the electrical socket is rated in the chart above. Lift cover upward on the receptacle to access the socket (Fig. 31). If the plug you are inserting does not match the socket construction, do not attempt any modifications as this could cause a hazard and will void any warranty.

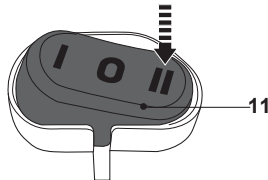

Fig. 30

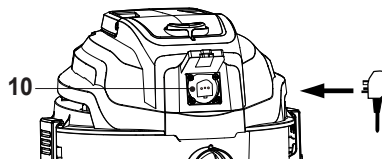

Fig. 31

## After use

- > Switch the product off and disconnect it from the power supply.
- > Disconnect the respective attachment, extension tube(s) (19) and hose (18) if necessary.
- > Let the product cool down.
- > Check, clean and store the product as described below.

## The golden rules for care



**WARNING!** Always switch the product off, disconnect the product from the power supply and let the product cool down before performing inspection, maintenance and cleaning work!



- > Keep the product clean. Remove debris from it after each use and before storage.
- > Regular and proper cleaning will help ensure safe use and prolong the life of the product.
- > Inspect the product before each use for worn and damaged parts. Do not operate it if you find broken and worn parts.



**WARNING!** Only perform repairs and maintenance work according to these instructions! All further works must be performed by a qualified specialist!

## General cleaning

- > Clean the product with a dry cloth. Use a brush for areas that are hard to reach.
- > In particular clean the air vents / air outlet (13) after every use with a cloth and brush.
- > Remove stubborn dirt with high pressure air (max. 3 bar).



**NOTE:** Do not use chemical, alkaline, abrasive or other aggressive detergents or disinfectants to clean this product as they might be harmful to its surfaces.

- > Check for worn or damaged parts. Replace worn parts as necessary or contact an authorised service centre for repair before using the product again.

## Maintenance

Before and after each use, check the product and accessories (or attachments) for wear and damage. If required, exchange them for new ones as described in this instruction manual. Observe the technical requirements.

### Removing blockage



**WARNING!** Always switch the product off, disconnect the product from the power supply and let the product cool down before removing blockages!



Use proper tools to remove debris! Never use your bare hands!

- > Press the on / off switch (11) to position O to switch the product off.
- > Remove the attachment fitted onto the hose handle (18a) / extension tube (19).
- > Disassemble the tank (4) in reverse order of assembly and disconnect the hose (18) / extension tube(s) (19), according to the product configuration.
- > Replace the dust bag (26) with a new one, if necessary.
- > Check and tap the hose (18) / extension tube(s) (19) to remove dust and / or debris.
- > Re-fit the suitable accessories and attachments before resuming operation.
- > Press the on / off switch (11) to position I to switch the product on and let it run idle for 15 seconds to ensure blockage has been removed.

### Dust bag

- > Switch the product off and disconnect it from the power supply.
- > Remove the motor unit (2) in reverse order of assembly, disconnect the dust bag (26) from the inner opening of the air inlet (9) and remove it carefully from the tank (4).
- > Assemble a new dust bag onto the air inlet of the tank. Ensure the connection is properly sealed.
- > Refit the motor unit (2) and secure the connection with the tank (4) before resuming operation.

### Cartridge filter

- > Unlock the clasps (3) and remove the motor unit (2) from the tank (4).
- > Turn the motor unit (2) upside down and remove the cartridge filter (25) from the motor unit (2).
- > Tap the cartridge filter (25) on a solid surface to remove dust. Replace it with new one if worn or after heavy use if necessary.
- > Wash the cartridge filter. Once completely dry, refit the cartridge filter onto the motor unit.



**NOTE:** Do not use chemical, alkaline, abrasive or other aggressive detergents or disinfectants to clean the dust bag as they might be harmful to its surfaces/material.

## Spare parts / Replacement parts

The following parts of this product may be replaced by the consumer. Spare parts are available at an authorised dealer or through our customer service.

Description	Model no. or Specification
Foam sleeve (14)	TTU786ACC
Cartridge filter (15)	TTU790ACC
Dust bag (16)	TTU791ACC / TTU788ACC

## Repair

This product does not contain any parts that can be repaired by the consumer. Contact an authorised service centre or a similarly qualified person to have it checked and repaired.

## UK plug

If you need to replace the fitted plug, then follow the instructions below.

**IMPORTANT:** The wires in the mains lead are coloured in accordance with the following code:

Blue – Neutral Brown – Live

As the colours of the wire in the mains lead of this product may not correspond with the coloured marking identifying the terminals in your plug, proceed as follows. The wire, which is coloured blue, must be connected to the terminal, which is marked with N or coloured black. The wire, which is coloured brown, must be connected to the terminal, which is marked L or coloured red.



**WARNING!** Never connect live or neutral wires to the earth terminal of the plug, which is marked with E.

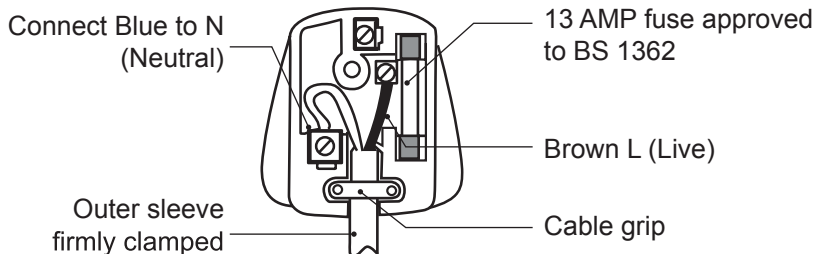

Only fit an approved BS 1363 or BS 1363/A plug and correctly rated BS 1362 13 Amp fuse. If in doubt, consult a qualified electrician.



**NOTE:** If a moulded plug is fitted and has to be removed take great care in disposing of the plug and severed cable, it must be destroyed to prevent engaging into a socket.

## Storage

- > Switch the product off and disconnect it from the power supply.
- > Disconnect the respective attachment (20, 21, 23), hose (18) and extension tube(s) (19) if necessary.
- > Clean and empty the product as described above.
- > To wash out the tank, use clean water instead of detergent. Do not immerse the tank (4) in water.
- > Once dry, we recommend putting the attachments onto the attachment storage (14) and storing the power cord (15) on the hook (17) of the motor unit (2) (Fig. 32).
- > Store the product and its accessories in a dark, dry, frost-free, well-ventilated place.
- > Always store the product in a place that is inaccessible to children. The ideal storage temperature is between 10 °C and 30 °C.
- > We recommend using the original package for storage or covering the product
- > with a suitable cloth or enclosure to protect it against dust.

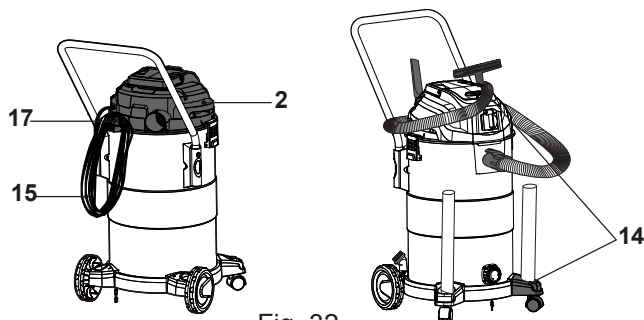

Fig. 32

## Transportation

- > Switch the product off and disconnect it from the power supply before transporting it anywhere.
- > Attach transportation guards, if applicable.
- > We recommend putting the attachments onto the attachment storage (14) and storing the power cord (15) on the hook (17) of the motor unit (2) (Fig. 32).
- > Protect the product from any heavy impact or strong vibrations which may occur during transportation in vehicles.
- > Secure the product to prevent it from slipping or falling over.

## Troubleshooting

Suspected malfunctions are often due to causes that the users can fix themselves. Therefore check the product using this section. In most cases the problem can be solved quickly.



**WARNING!** Only perform the steps described within these instructions! All further inspection, maintenance and repair work must be performed by an authorised service centre or a similarly qualified specialist if you cannot solve the problem yourself!

Problem	Possible Cause	Solution
1. Product does not start	1.1. Not connected to power supply	1.1. Connect to power supply
	1.2. Power cord or plug is defective	1.2. Check by a specialist electrician
	1.3. Other electrical defect to the product	1.3. Check by a specialist electrician
2. Product does not reach full power	2.1. Extension cord not suitable for operation with this product	2.1. Use a proper extension cord
	2.2. Power source (e. g. generator) has too low voltage	2.2. Connect to another power source
	2.3. Air vents / air inlet / air outlet are blocked	2.3. Clean the air vents / air inlet / air outlet
	2.4. Activated safety valve / too much water in the tank	2.4. Drain excess of water from the tank
3. The vacuum will stop picking up dust/water	3.1. Activated safety valve / too much water in the tank	3.1. Let the product cool down and then drain excess of water from the tank

Problem	Possible Cause	Solution
4. Unsatisfactory result	4.1. Attachment not suitable for working surface	4.1. Use proper attachment
	4.2. Dust bag is full	4.2. Replace with a new dust bag
	4.3. Dust bag is damaged	4.3. Replace with a new dust bag
	4.4. Cartridge filter damaged	4.4. Replace with a new Cartridge filter
	4.5. Attachment / extension tube(s) / hose not properly connected	4.5. Check and reconnect the involved part(s)
	4.6. Attachment / extension tube(s) / hose / handle / air inlet blocked	4.6. Remove the blockage(s) (see section Removing blockage)
	4.7. Attachment / extension tube(s) / hose / handle / air inlet defective	4.7. Replace involved part with a new one
5. Dust not being retained in the vacuum (dry vacuuming configuration)	5.1. Worn dust bag / dust filter	5.1. Replace with a new suitable part
	5.2. Dust bag / Cartridge filter not properly attached	5.2. Check and re-attach properly
	5.3. Defective attachment / extension tube / hose / handle / air inlet	5.3. Replace involved part with a new suitable one
6. Excessive vibration or noise	6.1. Attachment / extension tube(s) / hose not properly connected	6.1. Check and re-connect
	6.2. Loose screws/bolts/nuts on handle or wheels	6.2. Tighten screws/bolts/nuts

## Recycling and disposal



WEEE symbol. Waste electrical products should not be disposed of with household waste. Please recycle where facilities exist. Check with your Local Authority or local store for recycling advice.

The product comes in a package that protects it against damage during shipping. Keep the package until you are sure that all parts have been delivered and the product is working properly. Recycle the package afterwards.

# TITAN

**Manufacturer, Fabricant, Producent,  
Producător, Fabricante:**

**UK Manufacturer:**

Kingfisher International Products Limited  
3 Sheldon Square  
London  
W2 6PX  
United Kingdom

**EU Manufacturer:**

Kingfisher International Products B.V.  
Rapenburgerstraat 175E  
1011 VM Amsterdam  
The Netherlands



[www.diy.com](http://www.diy.com)

[www.screwfix.com](http://www.screwfix.com), [www.screwfix.ie](http://www.screwfix.ie)

To view instruction manuals online,  
visit [www.kingfisher.com/products](http://www.kingfisher.com/products)

---