



# Wall Mounted Microwave Sensor ZN29188

## LED Compatible



## Instruction

### Welcome to use ST752 Microwave Sensor!

The product is a new saving-energy switch; it adopts microwave sensor with high-frequency electro-magnetic wave (5.8GHz) and integrated circuit. It gathers automatism, convenience, safety, saving-energy and practical functions. The wide detection field depends on detectors. It works by receiving human motion. When one enters the detection field, it can start the load at once and identify automatically day and night. Its installation is very convenient and its using is very wide. Detection is possible to go through doors, panes of glass or thin walls.

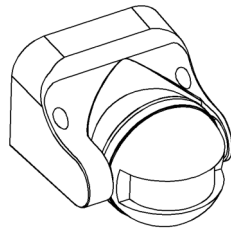

### SPECIFICATION:



Power Sourcing: 220 -240V/AC

Power Frequency: 50/60Hz

Ambient Light: <3-2000LUX (adjustable)

Time Delay: Min. 10sec±3sec

Max. 12min±1min

Rated Load: 1200W-  
300W 

Detection Range: 360°/180°

Detection Distance: 5-15m (adjustable)

HF System: 5.8GHz CW radar, ISM band

Transmission Power: <0.2mW

Installing Height: 1.5-3.5m

Power Consumption: approx 0.9W

Detection Motion Speed: 0.6-1.5m/s

### FUNCTION:

- Can identify day and night: It can work in the daytime and at night when it is adjusted on the "sun" position (max). It can work in the ambient light less than 3LUX when it is adjusted on the "3" position (min). As for the adjustment pattern, please refer to the testing pattern.
- SENS adjustable: It can be adjusted according to using location. The detection distance of low sensitivity could be only 5m and high sensitivity could be 15m which fits for large room.
- Time-Delay is added continually: When it receives the second induction signals within the first induction, it will restart to time from the moment.
- Time-Delay is adjustable. It can be set according to the consumer's desire. The minimum time is 10sec±3sec. The maximum is 12min±1min.

**NOTE: the high-frequency output of the HF sensor is <0.2mW- that is just one 5000<sup>th</sup> of the transmission power of a mobile phone or the output of a microwave oven, the baby can't touch it**

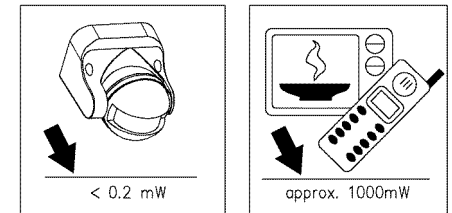

### INSTALLATION: (see the diagram)

- Shut off power.
- Loosen the screw on the bottom lid, open the wiring hole, pass the wire of power and load through the bottom lid.
- Fix the bottom lid with inflated screw on the selected position.
- Connect the power and load wire into connection-wire column according to the connecting figure.
- Put the sensor on the bottom lid, twist the screw tightly then electrify it and test it.

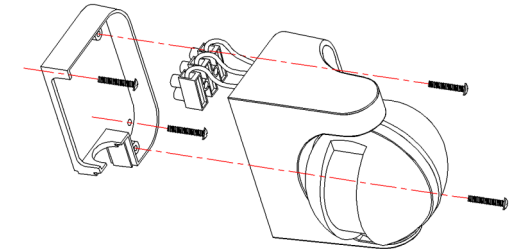

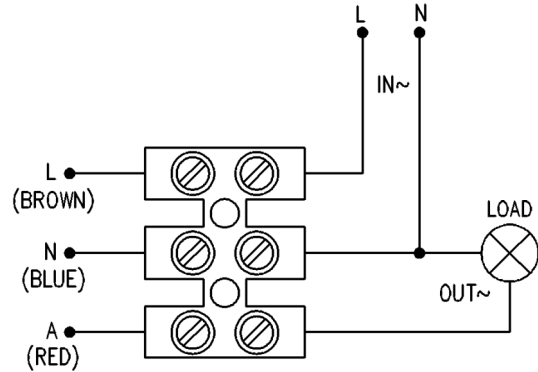

### CONNECTION-WIRE DIAGRAM:

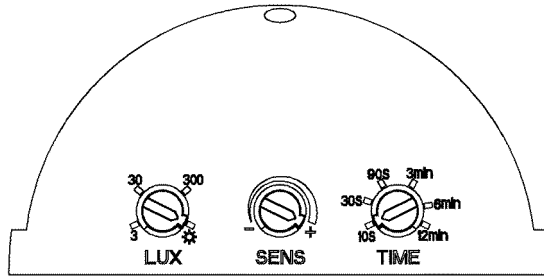

### TEST:

- Turn the LUX knob clockwise on the maximum (sun). Turn the SENS knob clockwise on the maximum (+). Turn the TIME knob anti-clockwise on the minimum (10s).
- When you switch on the power, the light will be on at once. And 10sec±3sec later the light will be off automatically. Then if the sensor receives induction signal again, it can work normally.
- When the sensor receives the second induction signals within the first induction, it will restart to time from the moment.
- Turn LUX knob anti-clockwise on the minimum (3). If the ambient light is less than 3LUX (darkness), the inductor load could work when it receives induction signal.



**Note:** when testing in daylight, please turn LUX knob  (SUN) position, otherwise the sensor lamp could not work!

### NOTES:

- Electrician or experienced human can install it.
- Can not be installed on the uneven and shaky surface
- In front of the sensor there shouldn't be obstructive object affecting detection.
- Avoid installing it near the metal and glass which may affect the sensor.
- For your safety, please don't open the case if you find hitch after installation.
- In order to avoid the unexpected damage of product, please add a safe device of current 6A

when installing microwave sensor, for example, fuse, safe tube etc.

### SOME PROBLEM AND SOLVED WAY

- The load don't work:
  - a. Check the power and the load.
  - b. Whether the indicator light is turned on after sensing? If yes, please check load.
  - c. If the indicator light is not on after sensing, please check if the working light corresponds to the ambient light.
  - d. Please check if the working voltage corresponds to the power source.
- The sensitivity is poor:
  - a. Please check if in front of the sensor there shouldn't be obstructive object that affect to receive the signals.
  - b. Please check if the signal source is in the detection fields.
  - c. Please check the installation height.
- The sensor can't shut automatically the load:
  - a. If there are continual signals in the detection fields.
  - b. If the time delay is set to the longest.
  - c. If the power corresponds to the instruction.

### Helpline

If you receive this item with parts broken or missing, please telephone:

**0333 005 0077**

Please have ready your name, address, tel. no., product reference, where purchased and parts required. An answering service is in operation outside office hours and during busy periods.

**We regret that we are unable to give advice on internal house wiring.**

Cascade Holdings Ltd, Gorse Mill, Gorse Street, Chadderton, Oldham. OL9 9RJ