



INSTRUCTION MANUAL

40" (102cm) TOWED STEEL PLUG AERATOR

MODEL NO: THTPA40 -- PRODUCT NO: 1938213001

EN - ORIGINAL INSTRUCTIONS

ASSEMBLY REQUIRED - MINIMUM TWO PERSONS

SAVE THESE INSTRUCTIONS

SPARES & SUPPORT: 01793 333212



FOR YOUR SAFETY

Please read & understand this manual, paying attention to the safety instructions, before use.

Incorrect use of the product could put the operator or machine in danger.

Whilst every effort has been made to ensure the accuracy of information contained in this manual, our policy of continuous improvement determines the right to make modifications without prior warning.

Images used are for illustration purposes only

Copyright Notice

Copyright © Handy Distribution

Permission is granted to reproduce this publication for personal & educational use only.

Commercial copying, redistribution, hiring or lending is prohibited.

No part of this publication may be stored in a retrieval system or transmitted in any other form or means without written permission from Handy Distribution.

In all cases this copyright notice must remain intact.

CONTENTS

SPECIFICATIONS

IMPORTANT INFORMATION

GENERAL SAFETY INSTRUCTIONS

KNOW YOUR MACHINE

COMPONENTS

ASSEMBLY

OPERATION

MAINTENANCE

STORAGE

PARTS DIAGRAM & LIST

WARRANTY

CE DECLARATION OF CONFORMITY

ASSEMBLY IS REQUIRED - MINIMUM TWO PERSONS

This product requires assembly before use. See "Assembly" section for instructions. Because of the weight and/or size of the aerator, it is recommended that another adult be present to assist with the assembly.

INSPECT ALL COMPONENTS closely upon receipt to make sure no components are missing or damaged.

TOOLS REQUIRED

- Rubber or Wooden Hammer
- 7 /16", 1/2" & 3 /4" Wrenches
- Adjustable Wrench
- Pliers

If you require assistance with regards to the contents or operation of the machine, please contact us:

TEL: 01793 333212

EMAIL: customerservice@handydistribution.co.uk

(MON – FRI 8.00AM TO 5.30PM EXCL. BANK HOLIDAYS)

SPECIFICATIONS

The manufacturer reserves the right to change the product specification and livery according to continued product improvements.

Model	THTPA40
Product Number	1938213001
Weight	N.W 35kg
Working Width	40" (102cm)
Tray Load Capacity	45kg (100lb)
Box & Frame	Steel
Overall Dimensions	L143.5 x W108 x H88.6cm
Plug Spikes (Total)	24
Max Aeration Depth	3" (7.6cm)
Plug Spike Diameter	5/8"
Tyre	Pneumatic - 10.5x4" (26.6x10cm)
Recommended Tyre Pressure	25 PSI
Hitch Type	Pin
Weight	35kg

IMPORTANT INFORMATION

INTENDED USE

The towed aerator is designed for use in private gardens and primarily used around **GRASS OR LAWN AREAS**, but not in public facilities, parks or sports grounds and not for agricultural or forestry use. Never exceed the rated load capacity of 45kg (100lb).

This is a garden aerator, therefore extended use over abrasive surfaces (e.g. concrete, tarmac etc.) could cause premature wear on the tyres. Commercial or industrial environments are not recommended.

When operating with a tractor, do not exceed 5mph.

Generally acknowledged accident prevention regulations and enclosed safety instructions must be observed.

Only perform work described in these instructions for use, any other use is incorrect. The manufacturer will not assume responsibility for damage resulting from such use.



WARNING

Read this instruction manual carefully before operating this machine. Make sure that you are familiar with the controls and properly operate the machine. Following these instructions can reduce the risk of personal injury.

IF NOT USED PROPERLY THIS MACHINE CAN BE DANGEROUS!

This machine can cause serious injury to the operator and others, the warning and safety instructions must be followed to ensure reasonable safety and efficiency in using this product. The operator is responsible for following the warning and safety instructions in this manual and on the machine. Never use the product unless the components are correctly positioned and operational.

TRAINING

Read the instructions carefully: Be familiar with the controls and the proper use of the equipment.

Never allow children or people unfamiliar with these instructions to use the product.







Local regulations can restrict the age of the operator.

Keep in mind that the operator or user is responsible for accidents or hazards involving the machine that occur to other people or their property.

GENERAL SAFETY INSTRUCTIONS

It is important that you read and understand the owner's manual and labels affixed to the machine. Learn its application and limitations as well as the specific potential hazards. Retain these instructions for future reference. The operator is responsible for following the warnings & instructions in this manual and on the product.

SAFETY SYMBOLS

	Read & understand the operator's manual for the aerator and the ride on product used to pull the aerator before using the machine. Failure to follow instructions could result in death or serious injury.		Risk of Slicing. Keep hands out of the way of all moving parts.
	Wear gloves to protect your hands. Wear foot protection at all times.		Safety alert symbol. Used to alert you to potential personal injury hazards. Obey all safety messages that follow this symbol to avoid possible injury.
 DANGER	Indicates an imminently hazardous situation which, if not avoided, will result in serious injury.	 WARNING	Indicates a potentially hazardous situation which, if not avoided, could result in serious injury.
 CAUTION	Indicates a potentially hazardous situation which, if not avoided, may result in minor or moderate injury.	CAUTION	Used without the safety alert symbol indicates a potentially hazardous situation which, if not avoided, may result in property damage.

IMPORTANT SAFETY WARNINGS

TO REDUCE RISK OF INJURY: Before any use be sure everyone using this product reads and understands all safety instructions and other information contained in this manual.

GENERAL SAFETY

STAY ALERT

Do not operate the machine while under the influence of drugs, alcohol, or any medication that could affect your ability to use it properly. Do not use this machine when you are tired or distracted from the job at hand. Be aware of what you are doing at all times. Use common sense.

USERS

Do not at any time carry passengers sit or stand on the aerator. Do not allow children to play on, stand upon or climb on the aerator. Never allow children or people unfamiliar with these instructions to use the machine. Local regulations can restrict the age of the operator.

AVOID DANGEROUS CONDITIONS

Work in daylight or in good artificial light; always be sure of your footing on slopes; walk, never run with the machine; exercise extreme caution when changing direction on slopes; do not work on excessively steep slopes; use extreme caution when reversing or pulling the machine towards you; do not put hands or feet near or under rotating or moving parts.

KEEP BYSTANDERS AND CHILDREN AWAY

Keep unauthorised persons a safe distance away from the machine. If approached, stop the machine immediately. Do not allow children to handle, climb on or use the machine. Keep in mind the operator or user is responsible for accidents or hazards occurring to other people or their property.

INSPECT YOUR MACHINE

Check all bolts, nuts, and screws for tightness before each use, especially those securing guards and drive mechanisms. Vibration during use, may cause these to loosen.

Form a habit of checking to see that all other tools/equipment are removed from the working area before turning it on. Replace damaged, missing or failed parts before using it. Warning labels carry important information. Replace any missing or damaged warning labels.

DRESS PROPERLY

Do not wear loose clothing, gloves, scarfs, neckties or jewellery (rings, wrist watches), which can be caught in moving parts. Always wear long trousers. Always wear substantial non slip, substantial or heavy-duty safety footwear are highly recommended when working. Never operate barefoot or when wearing sandals. Wear a face or dust mask if the operation is dusty. Always wear safety glasses/goggles and/or face shields. Everyday eyeglasses have only impact resistant lenses; they are not safety glasses/goggles. Wear protective hair covering to contain long hair, preventing it from getting caught in machinery.

DO NOT OVERREACH

Always keep proper footing and balance when using the machine. Use on slopes with great care. Never stand on the machine. Serious injury could occur if the machine is tipped or if the moving parts are unintentionally contacted. Do not store anything above or near the machine, where anyone might stand on the machine to reach them.

AVOID INJURY FROM UNEXPECTED ACCIDENT

Keep hands & feet out of the way of all moving parts. Do not place any part of your body or any tool e.g. in the machine during operation.

DO NOT FORCE TOOL

Do not exceed equipment maximum load capacity of 45kg (100lb). Avoid large holes and ditches when transporting loads. Always work within the rated capacity. Do not use machine for a purpose for which it was not intended. Be careful when operating on steep grades (hill) the aerator may tip over. Always operate at reduce speed in rough terrain, along creeks, ditches and on hillsides. Do not operate close to creeks, ditches and public highways. To avoid personal injury and/or equipment damage **DO NOT EXCEED 5 MPH**. Always use caution when loading and unloading the aerator. Only tow with recommended vehicles (Lawn/Garden Tractors and ATVs). Always secure and lock aerator to the vehicle hitch before operating.

TYRE INFLATION

Only use HAND or FOOT manual operated tyre inflation machines, not mechanical and do not exceed recommended PSI.

NEVER LEAVE MACHINE RUNNING UNATTENDED

Do not leave the machine unattended until it has come to a complete stop.

INSPECT

Before using, always visually inspect to see that the tools are not worn or damaged. Replace worn or damaged elements and bolts in sets, to preserve balance.

MAINTAIN YOUR MACHINE WITH CARE

Clean the machine immediately after use. Keep the machine clean to ensure it operates to it's full and safest performance. When maintaining this machine, only the manufacturer's original replacement parts should be used. The use of non-original manufacturer parts may invalidate your warranty.

PROTECT THE ENVIRONMENT

Take left over materials to an authorised collection point or follow the stipulations in the country where the machine is used. Do not discharge into drains, soil or water.

STORE IDLE EQUIPMENT

When not in use, the machine should be stored in a dry location. Keep the machine away from children and others not qualified to use it. Keep away from direct sunlight.



WARNING

The warnings, cautions, and instructions outlined in this instruction manual cannot cover all possible conditions or situations that may occur. It must be understood by the operator that common sense and caution are factors which cannot be built into this product and must be supplied by the operator.

KNOW YOUR MACHINE

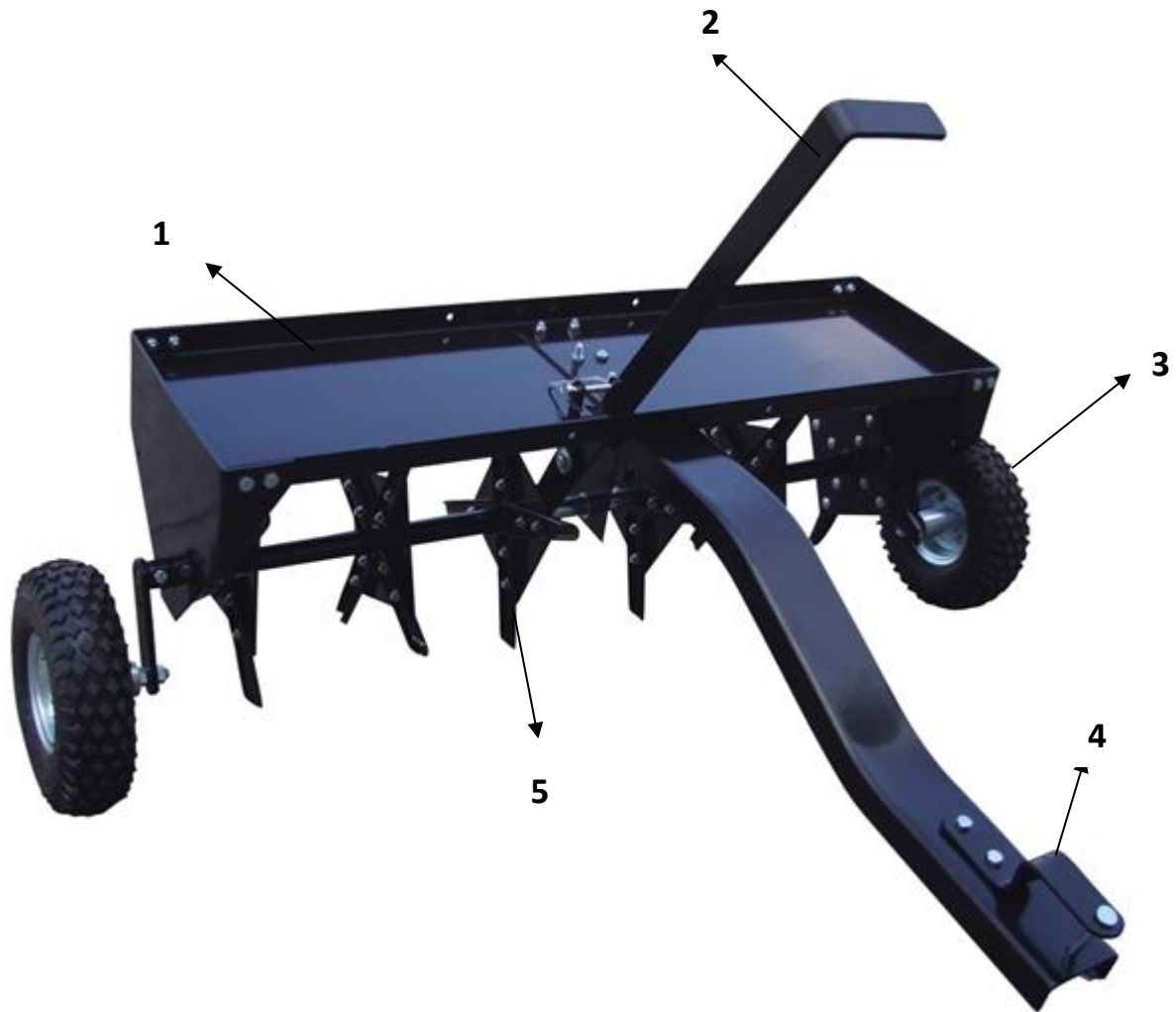

1.	Steel Load Bay Do not exceed 45kg (100lb)
2.	Lift Handle Positions plug spikes up or down.
3.	Wheel & Tyre Assembly Do not exceed recommended 25 PSI pressure
4.	Hitch Pin-type design for use with only approved ride on machinery
5.	Plug Spikes Pulls small soil plugs from ground.

COMPONENTS

This product must be assembled correctly before use. Carefully remove the product and any accessories from the carton. Inspect the product carefully to make sure there are no breakages or damage occurred during shipping. Do not discard the packing material and carton until you have carefully inspected and satisfactorily operated the product.

Take all parts out of the carton and inspect components to ensure there are no missing pieces before starting to assemble the aerator.

TOOLS REQUIRED

- Rubber or Wooden Hammer
- 7 /16", 1/2" & 3 /4" Wrenches
- Adjustable Wrench
- Pliers

If you require assistance with regards to the contents or operation of the machine, please contact us:

TEL: 01793 333212

EMAIL: customerservice@handydistribution.co.uk

(MON – FRI 8.00AM TO 5.30PM EXCL. BANK HOLIDAYS)



WARNING

If any parts are damaged or missing do not operate this product until the parts are replaced. Failure to heed this warning could result in serious personal injury.

Do not attempt to modify this product or create accessories not recommended for use with this product. Any such alteration or modification is misuse and could result in a hazardous condition leading to possible serious personal injury.

Read and follow all instructions for assembly and operation. Failure to properly assemble this equipment could result in serious injury to the user or bystanders, or cause equipment damage.

ITEM	DESCRIPTION	QTY	ITEM	DESCRIPTION	QTY
A	1/2" x 4-7/16" Hex Bolt	2	M	Ø8 Flat Washer	12
B	1/4" x 1-9/16" Hex Bolt	3	N	Washer Ø32x4	4
C	5/16" x 1-3/16" Hex Bolt	6	P	Ø20 Flat Washer	4
D	5/16" x 7/8" Hex Bolt	8	Q	1/4" Spacer	8
E	5/16" x 1" Hex Bolt	8	R	1.61" Spacer	1
F	Lock Pin	1	S	0.79" Spacer	1
G	R Pin	1	T	1/4" Lock Nut	3
H	Hitch Pin	1	U	2.36" Long Spacer	1
I	1/2" Hex Nut	2	V	Shoulder Spacer	1
J	1/2" Lock Nut	2	W	2.76" Long Spacer	1
K	5/16" Lock Nut	22			
ITEM	DESCRIPTION	QTY	ITEM	DESCRIPTION	QTY
1	Tray	1	7	Hitch Bracket	1
2	Middle Brace	1	8	Pneumatic Wheel	2
3	End Plate	2	9	Wheel Bracket	3
4	Lift Handle	1	10	Double Plug Spool	2
5	Tongue	1	26	Single Plug Spool (Left)	1
6	Axle Shaft	1	37	Single Plug Spool (Right)	1

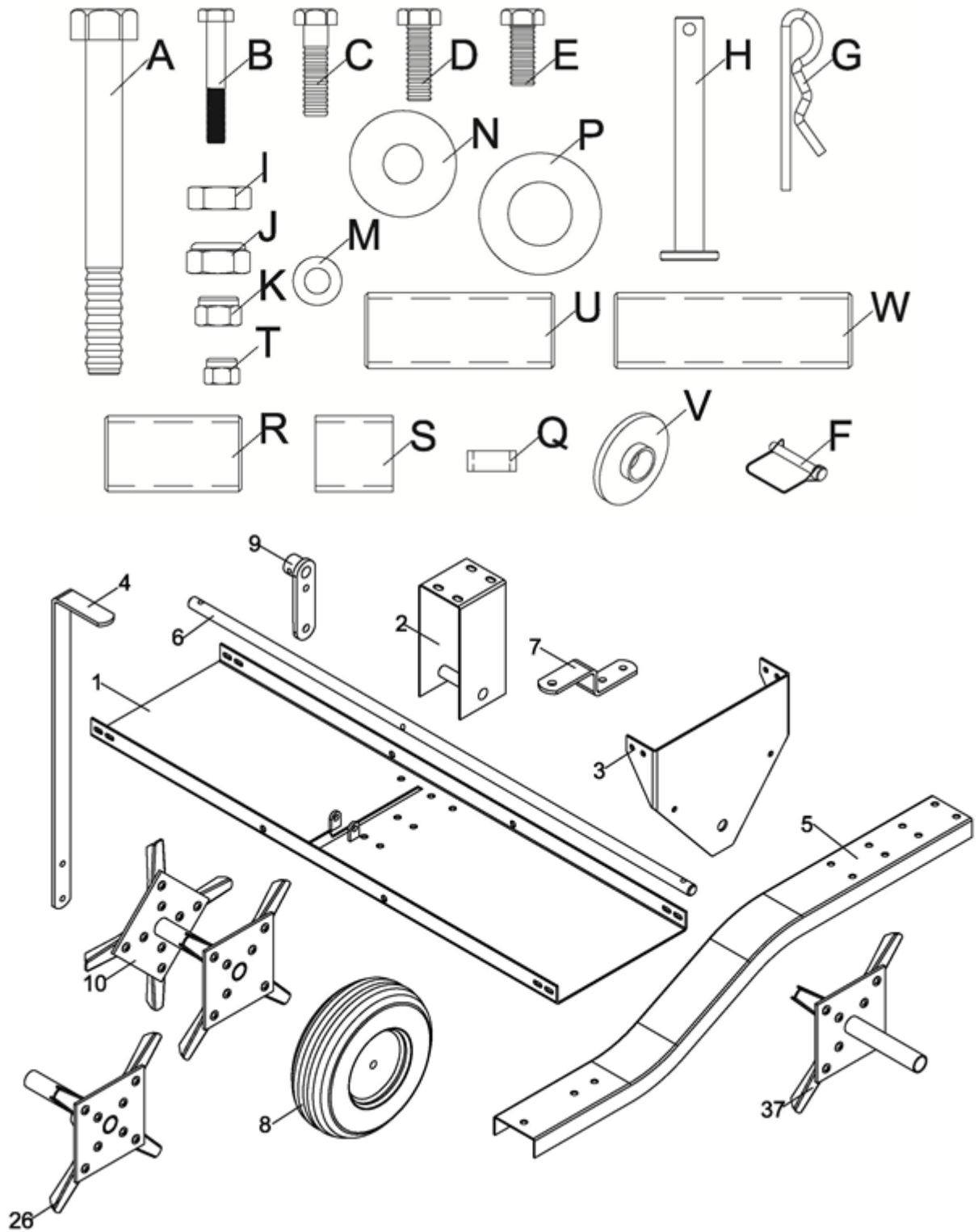

Note: you may have extra nuts & bolts when completed.

ASSEMBLY

All numbers mentioned in the below steps are listed in the parts list and diagram, located at the rear of this instruction manual.

STEP 1 - ATTACH WHEEL BRACKET TO THE AXLE SHAFT

1. Slide the wheel bracket (9) over the axle shaft (6) and position over the center axle hole using $1/4"$ x $1-9/16"$ hex bolt (B) and loosely tighten the $1/4"$ lock nut (T).
2. On the short side of the axle shaft insert $5/16"$ x $1-3/16"$ hex bolt (C) into the bottom hole on the wheel bracket (9) and loosely tighten the $5/16"$ lock nut (K).

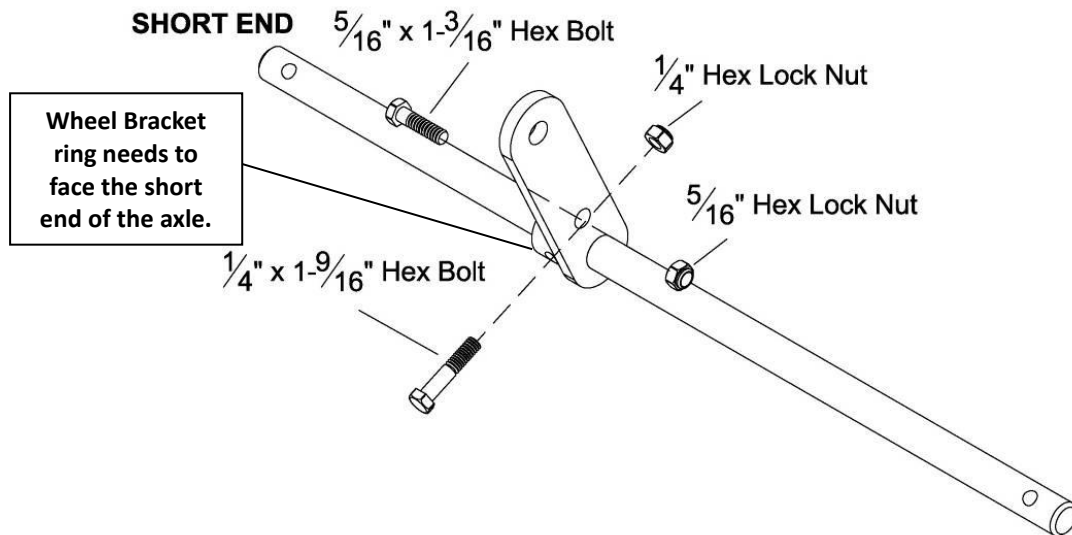

STEP 2 - SHORT SIDE AXLE SHAFT ASSEMBLY

Assemble all of the items below onto the short side of the axle shaft in the following order.

- Double Plug Spool (10),
- Single Plug Spool (Right) (37),
- 2.36" Spacer (U),
- $\varnothing 20$ Flat Washer (P).

Make sure the plug spikes face outward.

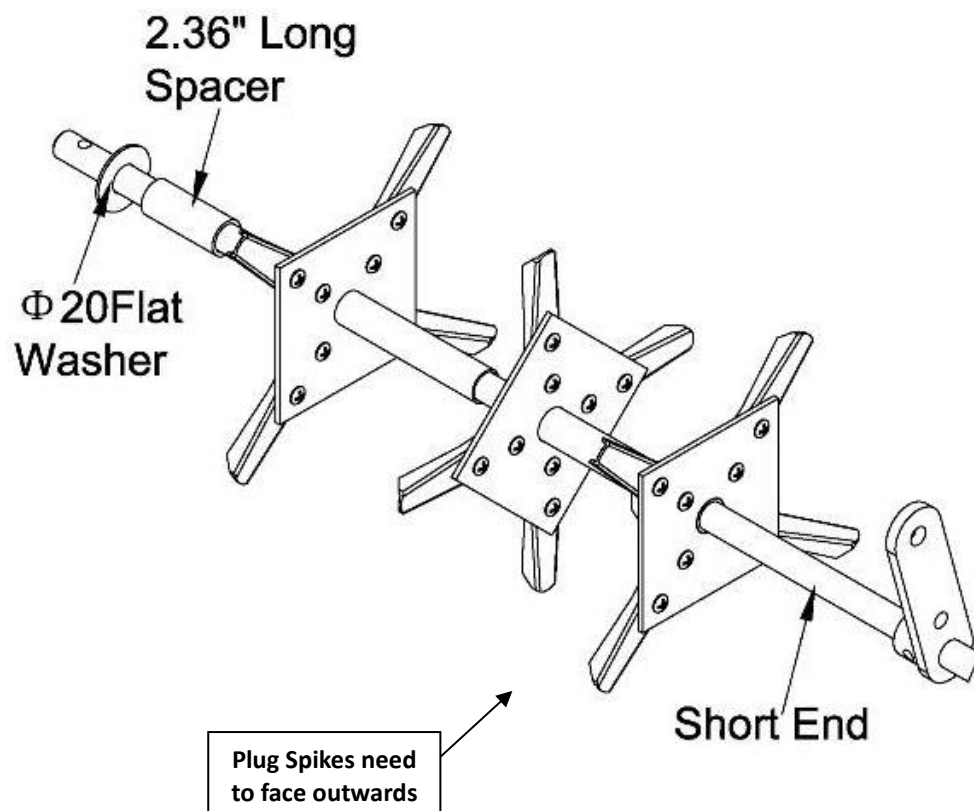



CAUTION

Before assembling the long side of the axle shaft, refer to the drawing below for the correct placement and direction of the middle brace bracket and plug spikes. Failure to follow these instructions will result in improper assembly

STEP 3 - LONG SIDE AXLE SHAFT ASSEMBLY

Assemble on the long side of the axle the items listed below in the following order.

- 0.79" Spacer (S),
- Ø20 Flat Washer (P),
- Middle Brace (2),
- Ø20 Flat Washer (P),
- 1.61" Spacer (R),
- Double Plug Spool (10),
- Single Plug Spool (Left) (26),
- 2.76" Spacer (W),
- Ø20 Flat Washer (P)

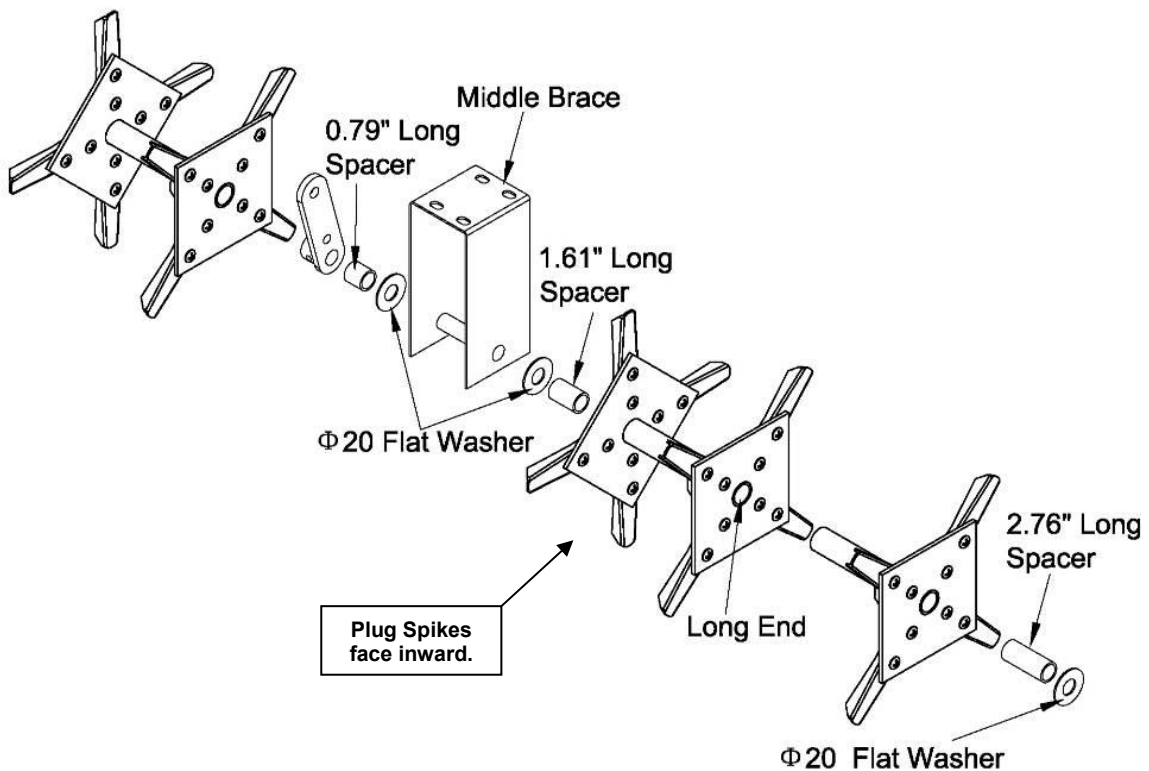

STEP 4 - ATTACH END PLATES & WHEEL BRACKETS

1. Attach end plate (3) using $\varnothing 20$ flat washer (P) and wheel bracket (9).
2. Rotate the wheel bracket (9) on the axle so it is pointing upward.
3. Fasten wheel bracket (9) to axle shaft using $1/4"$ x $1-9/16"$ hex bolt (B) and $1/4"$ lock nut (T) and tighten all hardware.
4. Repeat steps 1-3 for the other side and tighten all hardware.

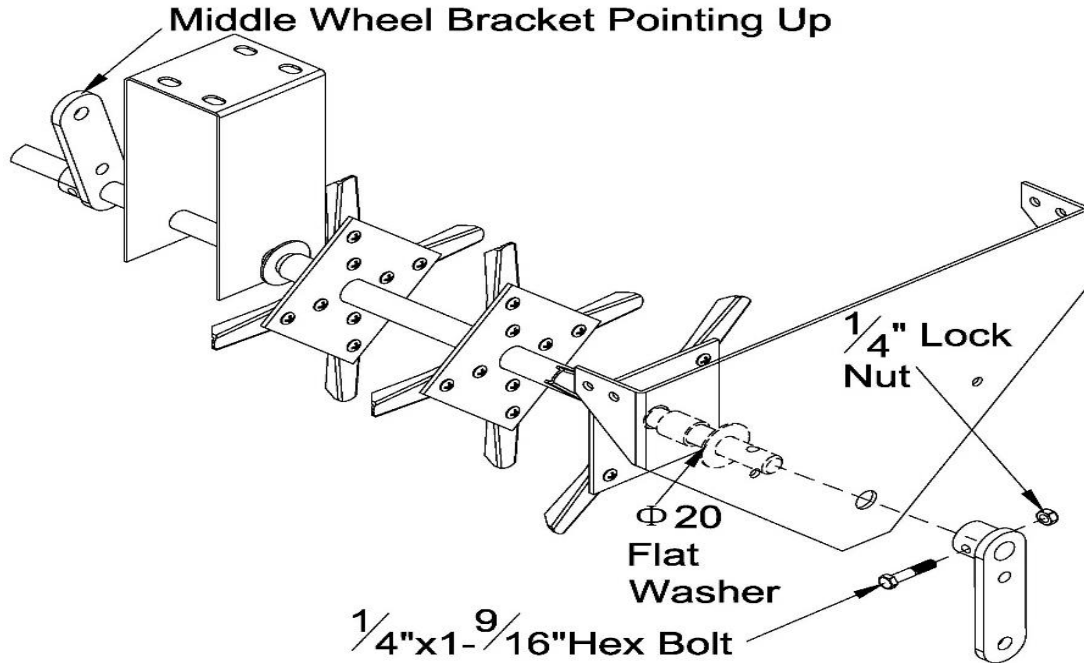

STEP 5 - WHEEL ASSEMBLY

1. Insert $1/2"$ x $4-7/16"$ hex bolt (A) through a $\varnothing 32$ x4 (N) washer and the wheel (8).
2. Put $\varnothing 32$ x4 (N) washer onto the $1/2"$ x $4-7/16"$ hex bolt (A) but on the inner side of wheel and the $1/2"$ hex nut (I) on the end and tighten, then loosen the hex nut (I) a $1/2$ turn.
3. Slide assembly through wheel bracket (9) and fasten with $1/2"$ lock nut (J).
4. Repeat steps 1-3 for the other side and tighten all hardware.

NOTE: Make sure the both wheels spin freely after assembly.

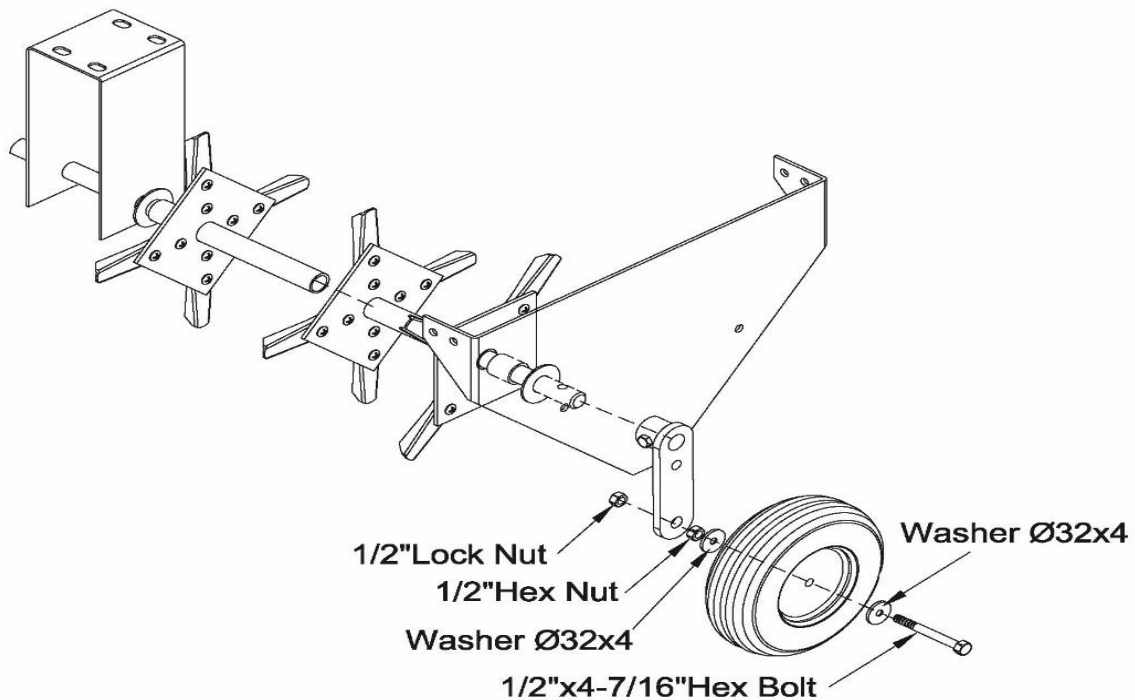

STEP 6 - ATTACH HITCH BRACKET & HITCH PIN

1. Attach hitch bracket (7) to the tongue (5) using 5/16" x 1" hex bolt (E) and 5/16" lock nut (K).
2. Insert hitch pin (H) through hitch bracket (7) and secure tongue (5) with R Pin (G) and fully tighten all hardware.

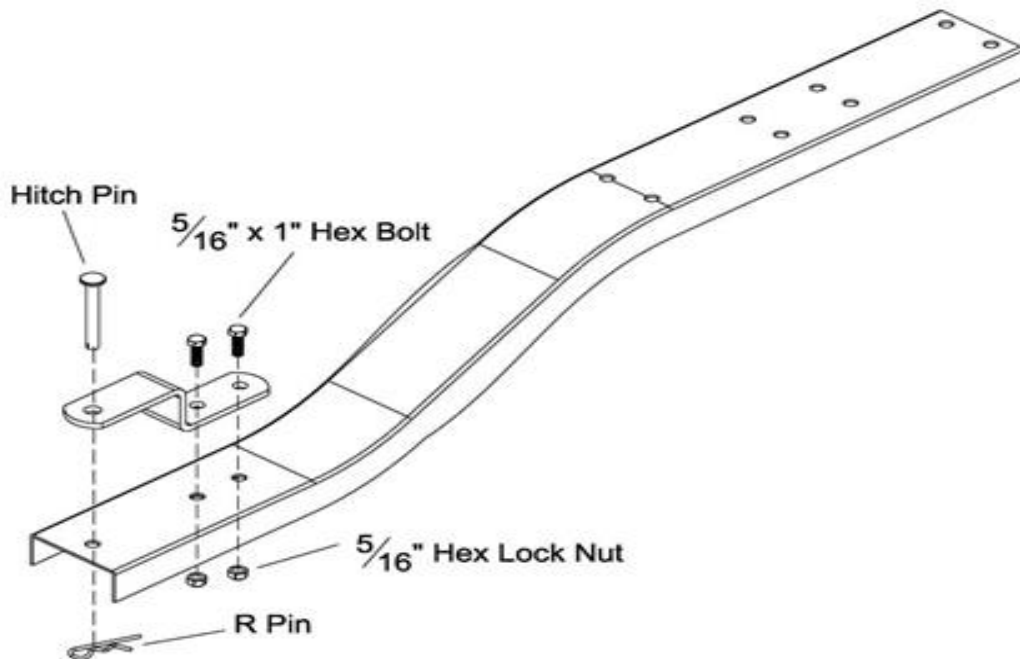

STEP 7 - ATTACH TONGUE ASSEMBLY TO TOP TRAY

1. Attach the tongue assembly to the top tray (1) with the open slot facing forward.
2. Attach the right side of tongue (5) using 5/16" x 1-3/16" hex bolt (C), two 1/4" Spacers (Q) per hex bolt (C) and tighten with 5/16" lock nut (K).
3. Attach front centre hole using 5/16" x 1" hex bolt (E) and secure with 5/16" lock nut (K). **DO NOT USE SPACERS ON CENTER HOLE.**
4. Attach outer left side of tongue (5) using 5/16" x 1-3/16" hex bolt (C), two 1/4" spacers (Q) per bolt, and tighten with 5/16" lock nut (K).
5. Tighten all hardware.

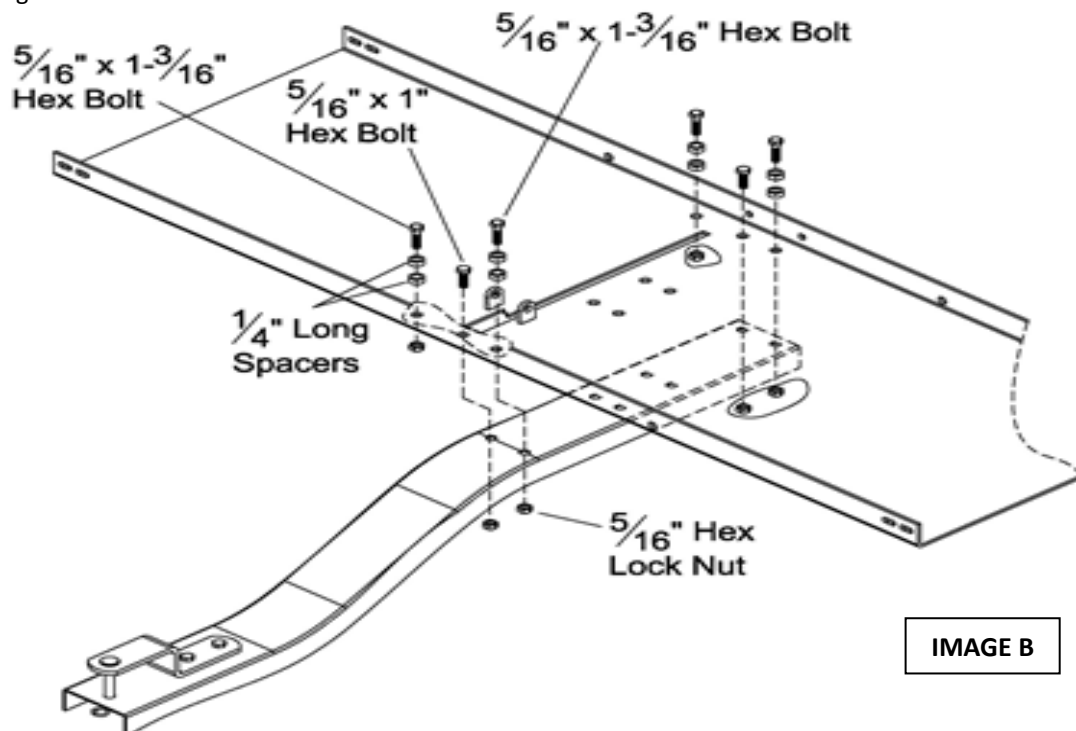
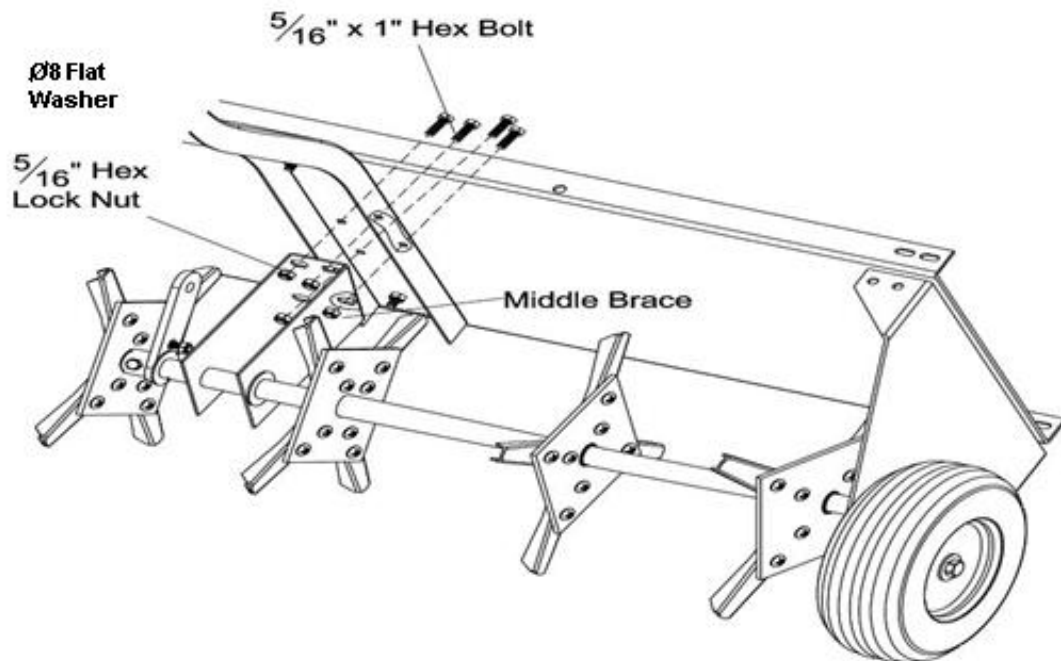
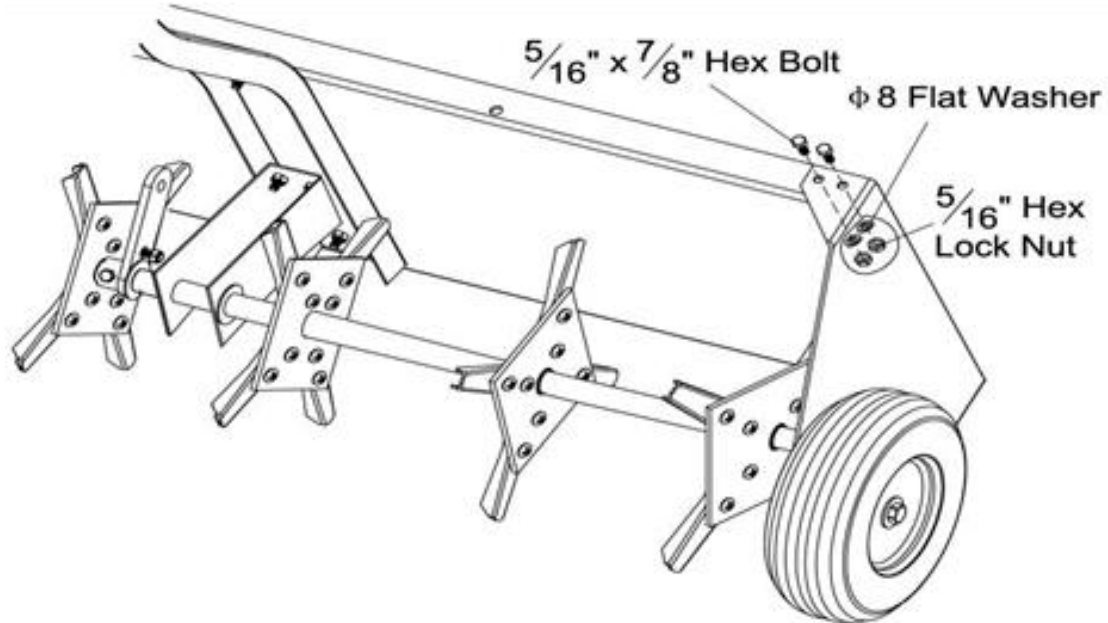

IMAGE B

STEP 8 - ATTACH MIDDLE BRACE

1. Position the tray (1) between both end plates (3), by leaning the top tray into the end plates.
2. Attach both end plates (3) to the tray (1) using $5/16"$ x $7/8"$ hex bolt (D), $\phi 8"$ flat washer (M) and secure with $5/16"$ lock nut (K) each corner. Each corner has two connections.
3. Repeat the steps for each corner.
4. Swing the middle brace bracket (2) into position and fasten to the top tray using $5/16"$ x $1"$ hex bolts (E), $\phi 8"$ flat washer (M) and loosely secure with $5/16"$ lock nut (K).



STEP 9 - ATTACH LIFT HANDLE

1. Place lift handle (4) through large tray slot and attach handle to the wheel bracket (9), bottom small hole using the 5/16" x 1-3/16" hex bolt (C) and 5/16" lock nut (K). Previously assembled in Step 2.
2. In the upper large hole attach the lift handle (4) using the 5/16" x 1-3/16" hex bolt (C), shoulder spacer (V) and secure with 5/16" lock nut (K).

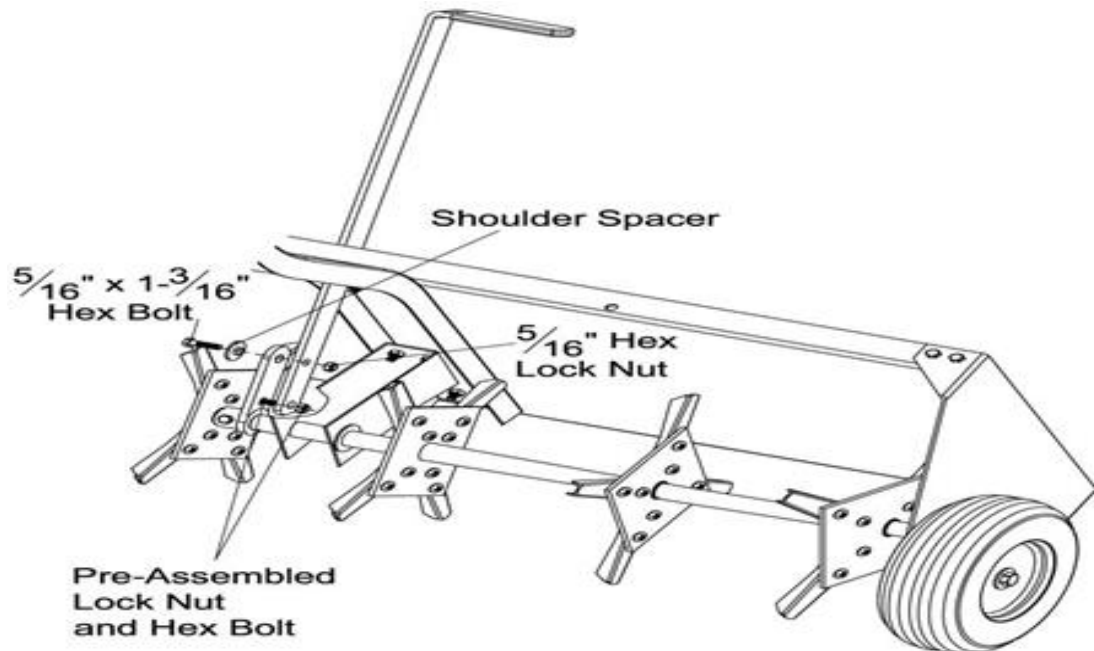

STEP 10 - ADJUST LIFT HANDLE & TIGHTEN CONNECTIONS

1. Place the aerator right side up, lock the lift handle (4) in the offset position at the front of the tray slot.
2. Perform the following to correct lift handle (4) alignment with the tray slot opening.
 - Adjust the tray (1) from side to side until the lift handle (4) rests against the front right side (viewed from rear) of the tray slot (offset).
 - Straighten the end plates (3) and then tighten the eight bolts on each corner of the tray, making sure the lift handle (4) still rests against the right side of the tray slot (offset).
 - Straighten the middle brace (2) and tighten the two bolts which fasten it to the tongue.
3. You will need some force to position the lift handle (4) into position when lowering the aerator.
4. Make sure all hardware is tight before operating the aerator.

NOTE: BEHIND THE LIFT ARM on the top tray is a place for a locking pin. Slide the locking pin through the holes with the aerator in the upright position. The safety lock keeps the aerator from dropping down while it is being towing and not in use. This will prevent damage to plug spikes.

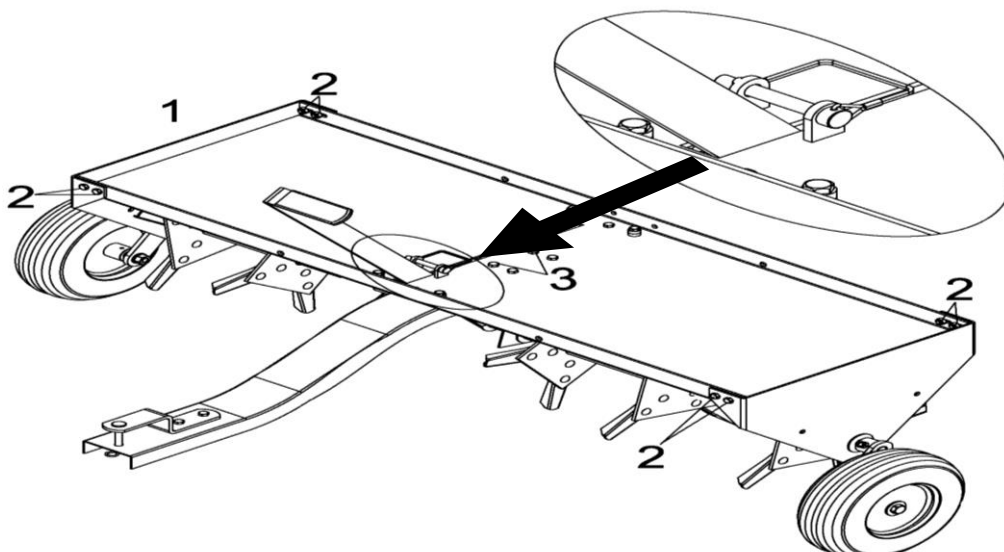

OPERATION



WARNING

Before using the aerator, review the instructions below and safety information. Failure to follow these instructions may result in property damage or injury to the operator or bystanders.

IMPORTANT:

Aerating is pulling small soil plugs up to three inches in length from the soil to create small reservoirs that will bring oxygen, fertilizer and water down to the roots. For best aerating results, follow the soil/lawn preparation and operating aerator procedures.

SOIL AND LAWN PREPARATION

1. Remove all debris from the work area.
2. If the ground is hard and dry, it is recommended the ground is watered for one or two hours prior to aerating.
3. If the ground is wet or muddy, **DO NOT** attempt to aerate.
4. Mow lawn and remove loose clippings before aerating.

USING YOUR AERATOR

1. **DO NOT** exceed rated load capacity of 45kg (100lb).
2. **ALWAYS** secure and lock the aerator to the ride on machinery hitch before operating.
3. **ONLY** use approved vehicles when towing the aerator (Lawn/Garden Tractors and ATVs).
4. **DO NOT** at any time carry passengers on the aerator.
5. Start vehicle engine with the controls in neutral position, put throttle at the slowest engine speed. Put transmission in low gear first and lower the aerator, allowing plug spikes to enter the ground. Increase the speed as work conditions permit.
6. Vehicle braking and stability may be affected with the attachment of this equipment.
7. **NEVER EXCEED 5MPH** when towing the aerator.
8. Aerate in the straightest line as possible, making overlapping passes to increase the plug spike point pattern.
9. **DO NOT** make sharp turns that may cause the vehicles tyres to rub against the aerator.
10. Avoid extremely sharp turns with plug spikes engaged to prevent damage to lawn.
11. **DO NOT** cross over paths or driveways, without raising the aerator to the transport position.
12. On sloped lawns, always aerate in an up and down direction. **DO NOT** attempt to aerate across the slope, always go in an up and down direction.
13. Always use caution when backing the aerator to avoid "jack-knifing". Always back up in a straight line.
14. To increase the depth of plug spike penetration, extra weight may be added to the tray (Max. 100lb). Use either bags of sand or concrete blocks. Always secure the weight to the tray with ties or straps fastened to the front and rear of the tray. The ties or straps cannot become entangled on rotating parts.

ATTACHING THE AERATOR TO THE TOW VEHICLE

- Park the tow vehicle and aerator on level ground.
- Set the height adjustment handle to middle of its adjustment.
- Insert the hitch pin through the hitch brackets and towing eye of the tow vehicle and secure with the cotter pin.



CAUTION

To avoid and prevent injury always dismount from approved vehicle to raise or lower aerator when extra weight has been added to the tray.

MAINTENANCE



WARNING

Improper maintenance and storage of the aerator may void your warranty.

- Rinse/dry inside and outside of the aerator after each use.
- Before operating make sure the tyres have the recommended 25 PSI tyre pressure (**DO NOT EXCEED**).
- Regularly grease the axle and the wheel bearing area or when needed.
- Periodically check all fasteners for tightness.
- Annually clean and lightly lubricate parts.
- Use a glossy enamel spray paint to touch up scratched or worn painted metal surfaces.
- Plug spikes periodically need to be sharpened with a small grinder to maintain good penetration. Spools should be removed to sharpen the points. Always follow the original angle and contour of the points when grinding. Ideally, this should be undertaken by an approved service dealer of your local garden machinery specialist.
- Never exceed load capacity rating of 45kg (100lb).

IMPORTANT:

If a part needs replacement, only use parts that meet the manufacturer's specifications. Replacement parts that do not meet specifications may result in a safety hazard or poor operation. Please contact our Parts Team for availability, who can be contacted Tel: 01793 333212, option 1 for assistance.

STORAGE

- Never allow material to remain on the aerator for extended periods of time.
- Before storing, make sure the aerator is clean and dry for years of trouble-free service.
- Store indoors or in a protected area during severe weather and winter months.
- When storing outside, always keep the tongue a little higher than the back of the aerator to allow the moisture to easily run out the back and will not accumulate on the aerator.

PARTS DIAGRAM – THTPA40 (1938213001)

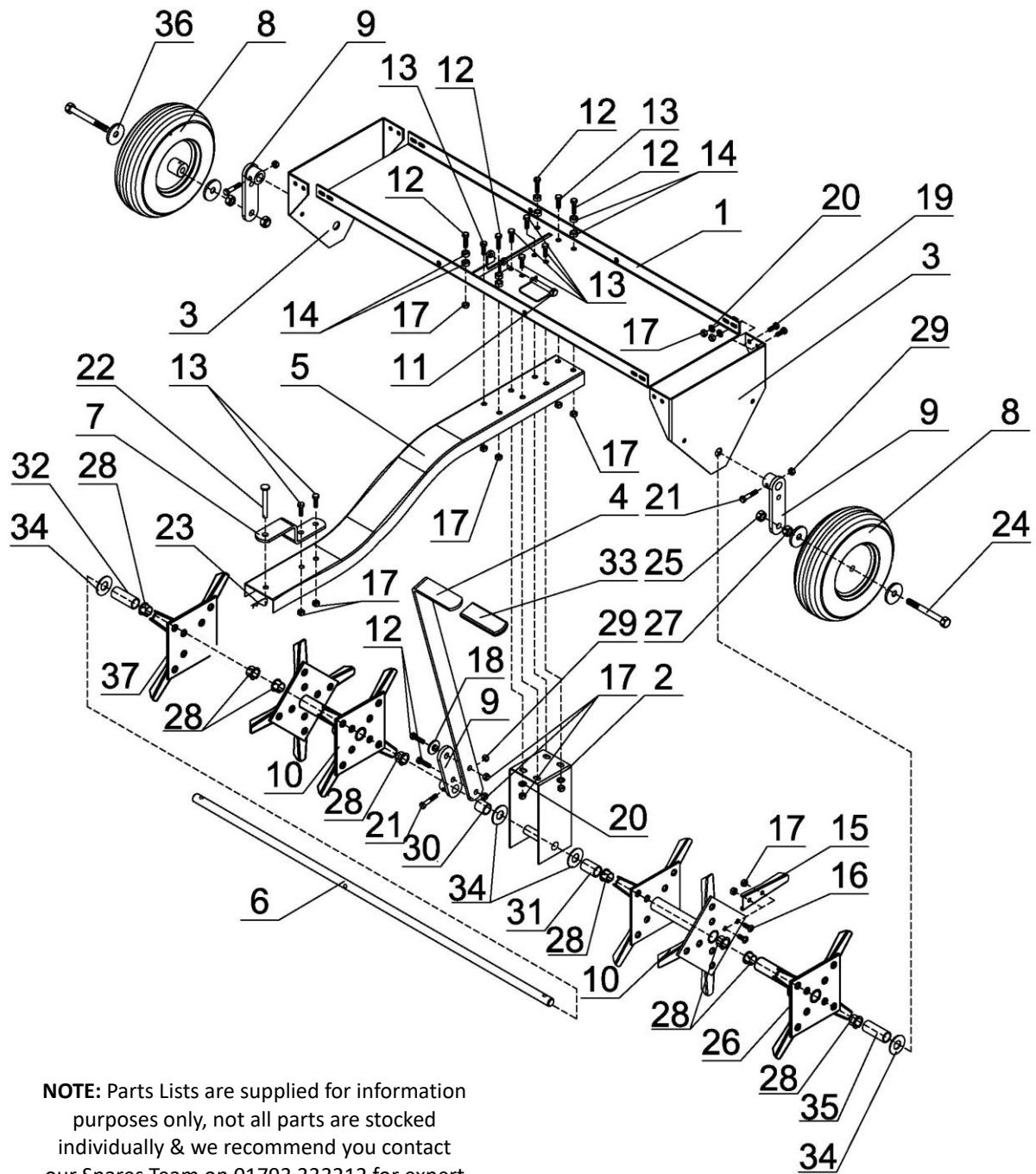

NOTE: Parts Lists are supplied for information purposes only, not all parts are stocked individually & we recommend you contact our Spares Team on 01793 333212 for expert advice.

PARTS LIST – THTPA40 (1938213001)

ITEM NO.	HANDY PART NO.	DESCRIPTION	QTY
1	TH255-1	Tray	1
2	TH255-2	Middle Brace	1
3	TH255-3	End Plate	2
4	TH255-4	Lift Handle	1
5	TH255-5	Hitch Tongue	1
6	TH255-6	Axle Shaft	1
7	TH255-7	Hitch Bracket	1
8	TH255-8	Wheel & Tyre Assembly	2
9	TH255-9	Wheel Bracket	3
10	TH255-10	Double Plug Spool	2
11	TH255-11	Lock Pin	1
12	TH255-12	Hex Bolt 5/16" x 1-3/16"	6
13	TH255-13	Hex Bolt 5/16" x 1"	8
14	TH255-14	1/4" Spacer	8
15	TH255-15	Knife Tool	24
16	TH255-16	Carriage Bolt 5/16" x 7/8"	48
17	TH255-17	Lock Nut 5/16"	70
18	TH255-18	Shoulder Spacer	1
19	TH255-19	Hex Bolt 5/16" x 7/8"	8
20	TH255-20	Flat Washer Ø8	12
21	TH255-21	Hex Bolt 1/4" x 1-9/16"	3
22	TH255-22	Hitch Pin	1
23	TH255-23	R Pin	1
24	TH255-24	Hex Bolt 1/2" x 4-7/16"	2
25	TH255-25	Lock Nut 1/2"	2
26	TH255-26	Single Plug Spool (Left)	1
27	TH255-27	Hex Nut 1/2"	2
28	TH255-28	Split Plastic Bearing	8
29	TH255-29	Lock Nut 1/4"	3
30	TH255-30	0.79" Spacer	1
31	TH255-31	1.61" Spacer	1
32	TH255-32	2.36" Spacer	1
33	TH255-33	Handle Grip	1
34	TH255-34	Flat Washer Ø20	4
35	TH255-35	2.76" Spacer	1
36	TH255-36	Washer Ø32x4	4
37	TH255-37	Single Plug Spool (Right)	1

GJ HANDY & CO LTD USER WARRANTY POLICY

Users Statement of Warranty

Each new machine is warranted against defective material or assembly of material under normal usage. The warranty applies to the original purchaser and covers faulty parts and the labour involved in replacing and repairing those parts, which are of original manufacture.

Period of Warranty

Webb (excludes Electric Handheld, Dynamic, Heritage, Legacy), Webb Pro, Sanli Engine

- a) 2 years from the original date of sale to the first domestic user.
- b) 90 days from the original date of sale to the professional/commercial user.
- c) 90 days from the original date of sale when used for hire.
- d) A reduced warranty period of 90 days applies to those items which are subject to normal wear and tear (e.g. but not limited to wheels, tyres, cutter bars, cylinders, cutting blades, blade boss, belts, cables, nylon line & spool, collection bags, spark plugs).
- e) Engines are supplied with a separate warranty to the machine. The engine manufacturers warranty statement which will be supplied within the engine instruction manual. All enquiries and warranty repairs should be discussed with the engine manufacturer or approved warranty repair dealer.
- f) 90 days from the original date of purchase for Replacement Spare Parts (unless normal wear & tear component, which are covered for 30 days).
- g) All machines' must be serviced within the first 12 months from the original date of purchase to comply with the warranty, failure to do so will invalidate the 2nd year of the warranty.

Webb Electric Handheld, Webb Dynamic, Heritage & Legacy, Handy, Mowerland, Q-Garden

- a) 1 year from the original date of sale to the first domestic user.
- b) 90 days from the original date of sale to the professional/commercial user.
- c) 90 days from the original date of sale when used for hire.
- d) A reduced warranty period of 90 days applies to those items which are subject to normal wear and tear (e.g. but not limited to wheels, tyres, cutter bars, cylinders, cutting blades, blade boss, belts, cables, nylon line & spool, collection bags, spark plugs).
- e) Engines are supplied with a separate warranty to the machine. The engine manufacturers warranty statement which will be supplied within the engine instruction manual. All enquiries and warranty repairs should be discussed with the engine manufacturer or approved warranty repair dealer.
- f) 90 days from the original date of purchase for Replacement Spare Parts (unless normal wear & tear component, which are covered for 30 days).

All warranty repairs must be undertaken by an authorised service dealer. These dealers have been accredited by GJ Handy & Co Ltd and agree to only use genuine parts and follow our repair procedures.

Not covered by this warranty

- a) The warranty policy does not cover any depreciation or damages caused by ordinary wear, rusting or corrosion, lack of correct maintenance or operation, misuse, abuse, lack of transportation or accident.
- b) The warranty policy does not cover any costs necessary for the standard periodic maintenance services instructed by the operator's manual, or service parts replacement which would include oil, filters, tyres, belts, brake linings, fuses, blades, seals and other service parts unless it can be proven that the item has evidence of faulty manufacture.
- c) The warranty policy will not cover failure or damage caused as a result of parts or accessories being modified without the written approval of GJ Handy & Co Ltd.
- d) The warranty policy will not cover the unit if non-genuine parts have been fitted and as a result damage has occurred to the unit.
- e) The warranty policy is non-transferable and is only applicable to the original purchaser.

Disclaimer

- a) This warranty is only a remedy for defect of products. GJ Handy & Co Ltd will never warranty in terms of the merchantability or the fitness for a particular purpose.
- b) No person is authorised to make any warranties, representations or promises, expressed or implied, on behalf of GJ Handy & Co Ltd, or to modify the terms conditions or limitation of this warranty policy in any way.
- c) Neither GJ Handy & Co Ltd nor any company affiliated with GJ Handy & Co Ltd shall be liable in any event or manner whatsoever for incidental or consequential damages or injuries, including, but not limited to, loss of crops, loss of profit, out of pocket expenses or profits, rental of substitute equipment or other commercial losses.

General

- a) Most warrantable failures show up within the first few weeks of use. These failures are usually straightforward and warranty assessment is relatively easy.
- b) Failures relating to cutter decks and belts need careful investigation, as the cause may not always be straightforward. Look for damage to blades and pulleys especially when the cutter belt or blade boss have snapped or cracked as this could be due to impact damage.
- c) Customers should always refer to the operator/instruction manual when any disputed problem arises, you will find most areas covered within the manual.



EC DECLARATION OF CONFORMITY

We Handy Distribution Ltd - SN3 5HY (Importer) declare that the product:

Designation: 40" (102cm) Towed Steel Garden Aerator

Model(s): THTPA40

Product Number: 1938213001

Type/Serial No: As per rating label on machine

Max Load Capacity: 45kg (100lb)

Complies with the following directives:

2006/42/EC – Machinery Directive

The conformity assessment procedure followed was in accordance with

EN ISO 12100:2010,

EN 349:1993+A1:2008,

EN ISO 1420:2015,

EN ISO 13857:2008

Notified Bodies:

ENTE CERTIFICAZIONE MACCHINE

Address(es):

Via Ca' Bella, 243 - Loc. Castello id Serravalle - 40053 Valsamoggia (BO) - ITALY

Authorised signatory & technical file holder

Date:

23/05/2019

Signature:

Name:

Mr. Simon Belcher

Position:

Chairman

Company:

Handy Distribution Ltd

Address:

Murdock Rd, Dorcan, Swindon, Wiltshire, SN3 5HY.

**For spares or support of your handy product,
please contact us:**

Tel: 01793 333212

**Email: customerservice@handydistribution.co.uk
(Mon – Fri 8.00am to 5.30pm excl. Bank Holidays)**

To see our range of garden machinery & equipment visit:

www.thehandy.co.uk

Making gardening easier & affordable since 1938

Distributed by Handy Distribution, Murdock Road, Dorcan, Swindon, SN3 5HY