



INSTRUCTION MANUAL

42" (107cm) TOWED LAWN SWEEPER

MODEL NO: THTLS42 -- PRODUCT NO: 1938210001

EN - ORIGINAL INSTRUCTIONS

ASSEMBLY REQUIRED - MINIMUM TWO PERSONS

SAVE THESE INSTRUCTIONS

SPARES & SUPPORT: 01793 333212



FOR YOUR SAFETY

Please read & understand this manual, paying attention to the safety instructions, before use.

Incorrect use of the product could put the operator or machine in danger.

Whilst every effort has been made to ensure the accuracy of information contained in this manual, our policy of continuous improvement determines the right to make modifications without prior warning.

Images used are for illustration purposes only

Copyright Notice

Copyright © Handy Distribution

Permission is granted to reproduce this publication for personal & educational use only.

Commercial copying, redistribution, hiring or lending is prohibited.

No part of this publication may be stored in a retrieval system or transmitted in any other form or means without written permission from Handy Distribution.

In all cases this copyright notice must remain intact.

CONTENTS

SPECIFICATIONS

IMPORTANT INFORMATION

GENERAL SAFETY INSTRUCTIONS

ABOUT YOUR LAWN SWEEPER

COMPONENTS

ASSEMBLY

OPERATION

MAINTENANCE

STORAGE

PARTS DIAGRAM & LIST

WARRANTY

CE DECLARATION OF CONFORMITY

ASSEMBLY IS REQUIRED - MINIMUM TWO PERSONS

This product requires assembly before use. See "Assembly" section for instructions. Because of the weight and/or size of the trailer, it is recommended that another adult be present to assist with the assembly. **INSPECT ALL COMPONENTS** closely upon receipt to make sure no components are missing or damaged.

If you require assistance with regards to the contents or operation of the machine, please contact us:

TEL: 01793 333212

EMAIL: customerservice@handydistribution.co.uk

(MON – FRI 8.00AM TO 5.30PM EXCL. BANK HOLIDAYS)

SPECIFICATIONS

The manufacturer reserves the right to change the product specification and livery according to continued product improvements.

Model	THTLS42
Product Number	1938210001
Weight	N.W 33kg
Working Width	42" (107cm)
Load Capacity	0.4m ²
Frame	Steel
Wheel Size	10.5" (27cm)
Hitch Type	Pin

IMPORTANT INFORMATION







INTENDED USE

The product is intended for domestic gardens. This product is not intended for commercial use. Generally acknowledged accident prevention regulations and enclosed safety instructions must be observed. Only perform work described in these instructions for use, any other use is incorrect. The manufacturer will not assume responsibility for damage resulting from such use.

GENERAL SAFETY INSTRUCTIONS

It is important that you read and understand the owner's manual and labels affixed to the machine. Learn its application and limitations as well as the specific potential hazards. Retain these instructions for future reference. The operator is responsible for following the warnings & instructions in this manual and on the product.

SAFETY SYMBOLS

	Read & understand the operator's manual for the trailer and the ride on product used to pull the trailer before using the machine. Failure to follow instructions could result in death or serious injury.		Risk of Slicing. Keep hands out of the way of all moving parts.
	Wear gloves to protect your hands. Wear foot protection at all times. Wear eye protection to protect against flying objects.		Safety alert symbol. Used to alert you to potential personal injury hazards. Obey all safety messages that follow this symbol to avoid possible injury.
 DANGER	Indicates an imminently hazardous situation which, if not avoided, will result in serious injury.	 WARNING	Indicates a potentially hazardous situation which, if not avoided, could result in serious injury.
 CAUTION	Indicates a potentially hazardous situation which, if not avoided, may result in minor or moderate injury.	CAUTION	Used without the safety alert symbol indicates a potentially hazardous situation which, if not avoided, may result in property damage.

IMPORTANT SAFETY WARNINGS



TO REDUCE RISK OF INJURY: Before any use be sure everyone using this product reads and understands all safety instructions and other information contained in this manual.

GENERAL SAFETY

STAY ALERT

Do not operate the machine while under the influence of drugs, alcohol, or any medication that could affect your ability to use it properly. Do not use this machine when you are tired or distracted from the job at hand. Be aware of what you are doing at all times. Use common sense.

USERS

Do not at any time carry passengers sit or stand on the machine. Do not allow children to play on, stand upon or climb in the machine. Never allow children or people unfamiliar with these instructions to use the machine. Local regulations can restrict the age of the operator.

AVOID DANGEROUS CONDITIONS

Work in daylight or in good artificial light; always be sure of your footing on slopes; walk, never run with the machine; exercise extreme caution when changing direction on slopes; do not work on excessively steep slopes; use extreme caution when reversing or pulling the machine towards you; do not put hands or feet near or under rotating or moving parts.

KEEP BYSTANDERS AND CHILDREN AWAY

Keep unauthorised persons a safe distance away from the machine. If approached, stop the machine immediately. Do not allow children to handle, climb on or use the machine. Keep in mind the operator or user is responsible for accidents or hazards occurring to other people or their property.

INSPECT YOUR MACHINE

Check all bolts, nuts, and screws for tightness before each use, especially those securing guards and drive mechanisms. Vibration during use, may cause these to loosen.

Form a habit of checking to see that all other tools/equipment are removed from the working area before turning it on. Replace damaged, missing or failed parts before using it. Warning labels carry important information. Replace any missing or damaged warning labels.

DRESS PROPERLY

Do not wear loose clothing, gloves, scarfs, neckties or jewellery (rings, wrist watches), which can be caught in moving parts. Always wear long trousers. Always wear substantial non slip, substantial or heavy-duty safety footwear are highly recommended when working. Never operate barefoot or when wearing sandals. Wear a face or dust mask if the operation is dusty. Always wear safety glasses/goggles and/or face shields. Everyday eyeglasses have only impact resistant lenses; they are not safety glasses/goggles. Wear protective hair covering to contain long hair, preventing it from getting caught in machinery.

DO NOT OVERREACH

Keep proper footing and balance at all times when using the machine. Use on slopes with great care. Never stand on the machine. Serious injury could occur if the machine is tipped or if the moving parts are unintentionally contacted. Do not store anything above or near the machine, where anyone might stand on the machine to reach them.

AVOID INJURY FROM UNEXPECTED ACCIDENT

Keep hands & feet out of the way of all moving parts. Do not place any part of your body or any tool e.g. in the machine during operation.

DO NOT FORCE TOOL

Always work within the rated capacity. Do not use machine for a purpose for which it was not intended. Be careful when operating on steep grades (hill) the machine may tip over. Always operate at reduce speed in rough terrain, along creeks, ditches and on hillsides. Do not operate close to creeks, ditches and public highways. To avoid personal injury and/or equipment damage DO NOT EXCEED 10 MPH. Always use caution when loading and unloading the machine. Only tow with recommended vehicles (Lawn/Garden Tractors and ATVs). Always secure and lock dump machine to the vehicle hitch before operating.

NEVER LEAVE MACHINE RUNNING UNATTENDED

Do not leave the machine unattended until it has come to a complete stop.

INSPECT

Before using, always visually inspect to see that the tools are not worn or damaged. Replace worn or damaged elements and bolts in sets, to preserve balance.

MAINTAIN YOUR MACHINE WITH CARE

Clean the machine immediately after use. Keep the machine clean to ensure it operates to it's full and safest performance. When maintaining this machine, only the manufacturer's original replacement parts should be used. The use of non-original manufacturer parts may invalidate your warranty.

PROTECT THE ENVIRONMENT

Take left over materials to an authorised collection point or follow the stipulations in the country where the machine is used. Do not discharge into drains, soil or water.

STORE IDLE EQUIPMENT

When not in use, the machine should be stored in a dry location. Keep the machine away from children and others not qualified to use it. Keep away from direct sunlight.



WARNING

The warnings, cautions, and instructions outlined in this instruction manual cannot cover all possible conditions or situations that may occur. It must be understood by the operator that common sense and caution are factors which cannot be built into this product and must be supplied by the operator.

ABOUT YOUR LAWN SWEEPER

This heavy-duty tow-behind lawn sweeper makes work a breeze. The steel and nylon construction are durable and lightweight, making it wear and rust-resistant, easy to tow, and easy to clean. The extra-large sweeping span makes jobs easy and saves time when cleaning different types of debris, from grass clippings, twigs, and leaves, to paper and much more. The tow-behind sweeper features a one-handed lever to adjust the brush height. It can be stored in a shed or garage with minimal space. The large hopper makes loading and unloading fast and convenient.

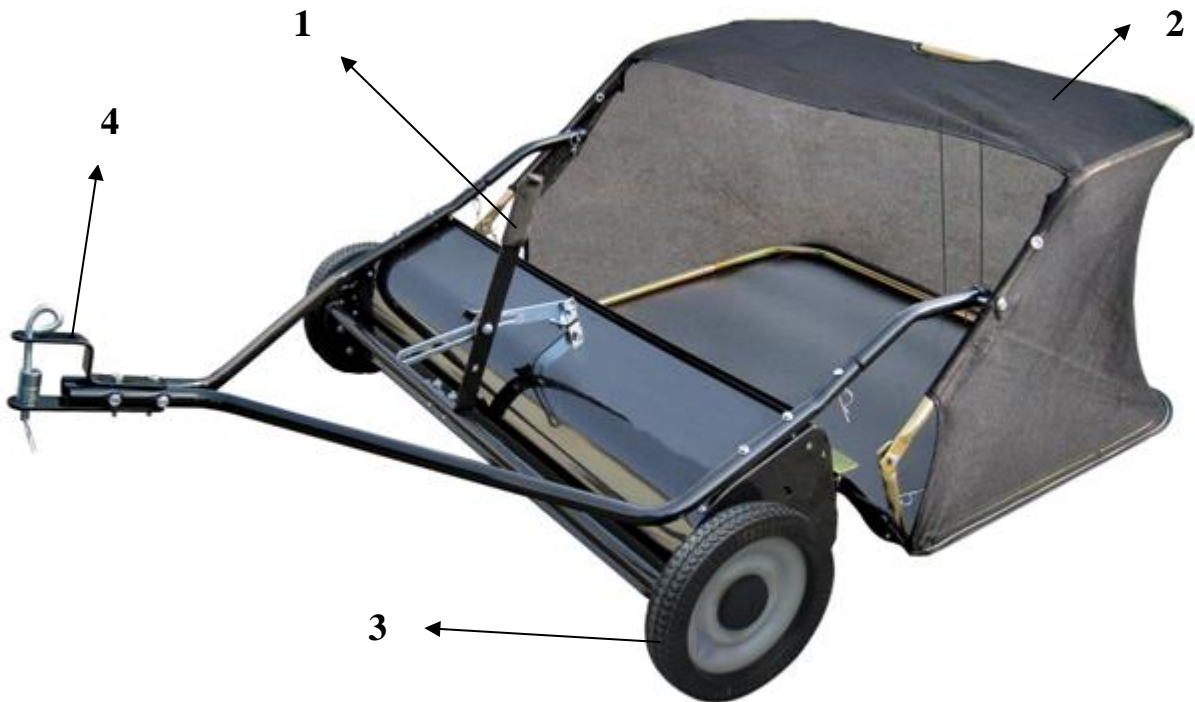

1.	Hand Lever Adjust the brush height	3.	Tyres Semi-pneumatic all-terrain tyres
2.	Nylon Hopper/Collector Holds debris	4.	Hitch Pin style; use only with approved vehicles.

COMPONENTS

This product must be assembled correctly before use. Carefully remove the product and any accessories from the carton. Inspect the product carefully to make sure there are no breakages or damage occurred during shipping. Do not discard the packing material and carton until you have carefully inspected and satisfactorily operated the product.

Take all parts out of the shipping crate and inspect components to ensure there are no missing pieces before starting to assemble the lawn sweeper.

TOOLS REQUIRED

10mm, 13mm & 14mm Wrenches

1x Pliers

If you require assistance with regards to the contents or operation of the machine, please contact us:

TEL: 01793 333212

EMAIL: customerservice@handydistribution.co.uk

(MON – FRI 8.00AM TO 5.30PM EXCL. BANK HOLIDAYS)



WARNING

If any parts are damaged or missing do not operate this product until the parts are replaced. Failure to heed this warning could result in serious personal injury.

Do not attempt to modify this product or create accessories not recommended for use with this product. Any such alteration or modification is misuse and could result in a hazardous condition leading to possible serious personal injury.

Read and follow all instructions for assembly and operation. Failure to properly assemble this equipment could result in serious injury to the user or bystanders, or cause equipment damage.

ITEM	DESCRIPTION	QTY	ITEM	DESCRIPTION	QTY
A	Hex Bolt M8x65	2	K	Angle Bracket	1
B	Hex Bolt M8x50	2	L	Adjustable Pole Spacer	1
C	Hex Bolt M8x40	2	M	Hitch Spacer	2
D	Hex Bolt M6x40	4	N	R Pin Ø3	5
E	Hex Bolt M8x20	1	O	R Pin Ø2	4
F	Hex Bolt M8x16	1	P	Clevis Pin Ø9.5x25	2
G	Nylon Lock Nut M8	8	Q	Clevis Pin Ø6x37	4
H	Nylon Lock Nut M6	6	R	Clevis Pin Ø8x59.5	2
I	Hex Bolt M6x12	2	Y	Hitch Pin	1
J	Big Flat Washer Ø8	1	Z	Plastic Plug	4

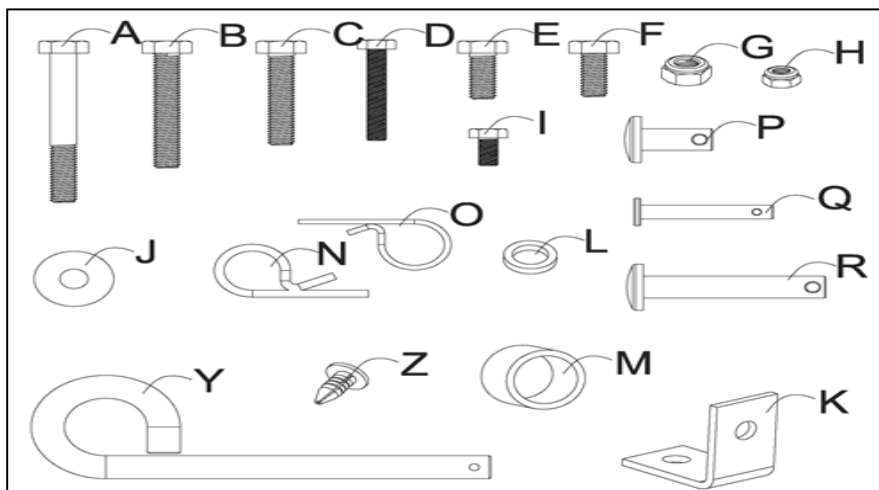

ITEM	DESCRIPTION	QTY	ITEM	DESCRIPTION	QTY
1	Hitch Tube (RH)	1	9	Bag Arm Tube	1
2	Hitch Tube (LH)	1	10	Bag Frame Strap	1
3	Handle Assembly	1	11	Hopper Support Rod	2
4	Hitch Bracket (Straight)	1	12	Lower Hopper Side Tube	2
5	Hitch Bracket	1	13	Rear Hopper Tube	2
6	Hopper Bag	1	14	Upper Hopper Side Tube	2
7	Connecting Rod	1	15	Rope	1
8	Sweeper Housing Assembly	2			

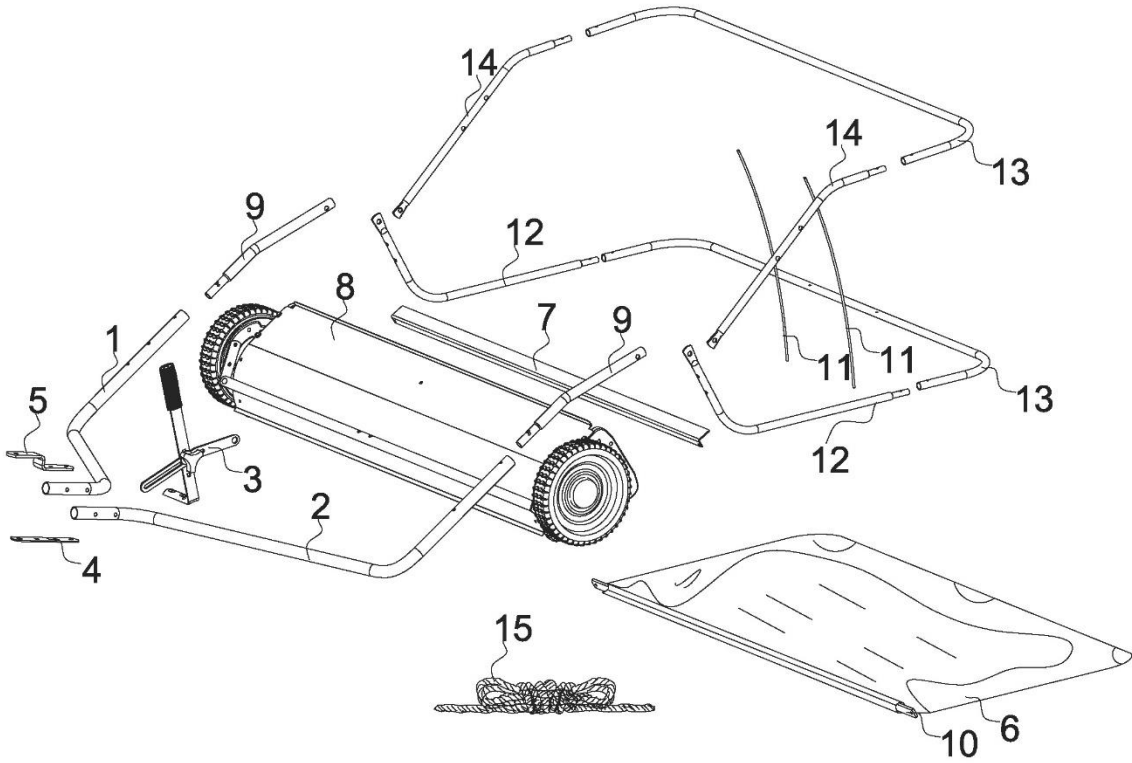

ASSEMBLY

Before assembling the lawn sweeper, lay out all of the parts and hardware as shown on the previous pages.

STEP 1 - MOUNT ANGLE BRACKET

Remove the three splints from the brushes.

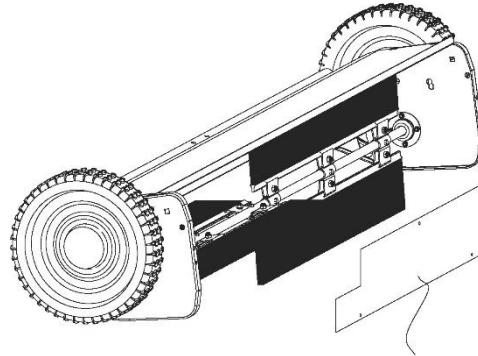

THREE SPLINTS, USED TO PROTECT BRUSHES IN TRANSPORT

Attach the Angle Bracket (K) to the sweeper housing by using the Hex Bolt M8x16 (F) and the Nylon Lock Nut M8 (G). **Tighten securely.**

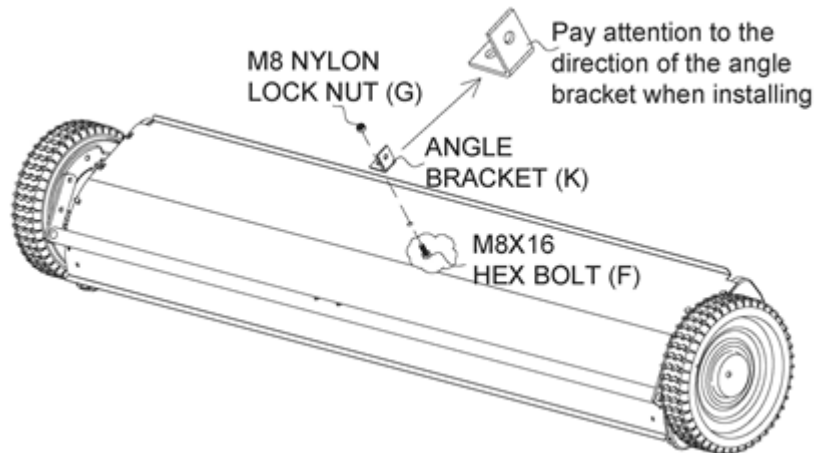

NOTE: Right Hand (RH) and Left Hand (LH) refer to the drivers' orientation when operating the vehicle.

STEP 2 - ATTACH HITCH TUBES

Attach the right-hand (RH) and left-hand (LH) hitch tubes (parts 1 and 2) to the sweeper housing assembly (part 6) using Hex Bolts M6x40 (D) and Nylon Lock Nuts M6 (H). **Tighten loosely.**

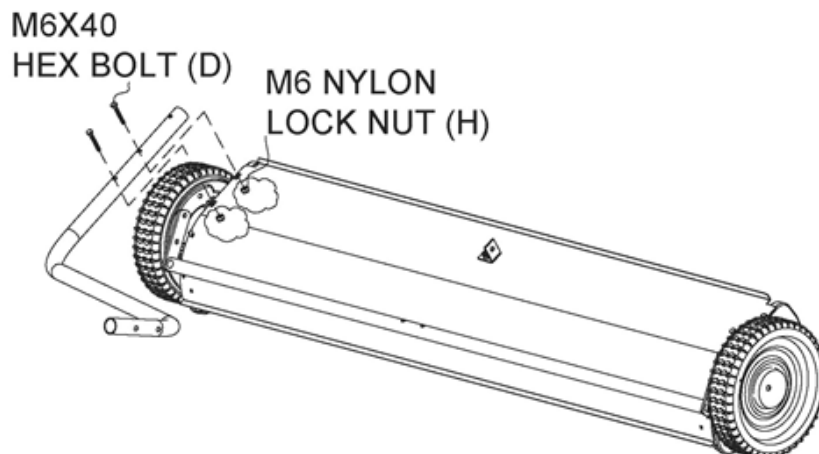

STEP 3 - SECURE HITCH TUBES TOGETHER

Once the Hitch tubes are attached, pass two Hex Bolts M8x75 (A) through the hitch-end (away from the sweeper body) of the tubes to connect them together using two Nylon Lock Nuts M8 (G). **Tighten loosely.**

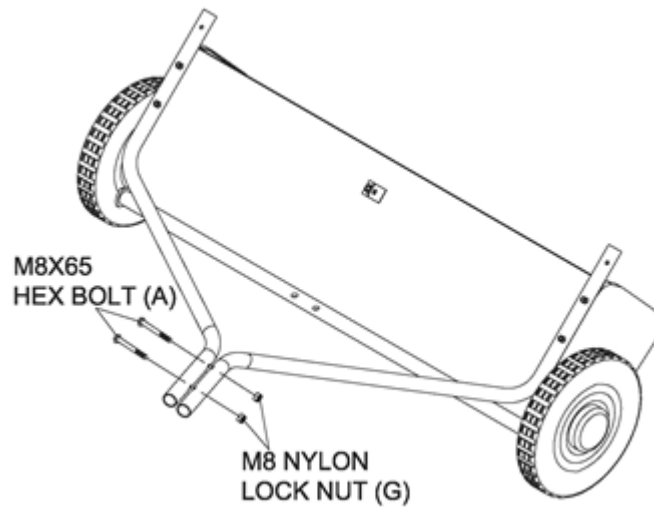

STEP 4 - MOUNT HITCH ASSEMBLY TO HITCH TUBES

NOTE: If your vehicle's tow hitch is between 8" and 10", mount the angled hitch bracket on the bottom of the hitch tubes for best performance (See Figure B). For vehicles 11" and higher, see Figure A.

Attach the Hitch assembly in the following order: (see figure A)

- Mount the angled hitch bracket on top of the hitch tubes, with the straight hitch bracket on the bottom.
- Pass two hex bolts M8x50 (B) through the angled hitch bracket, premade notches in the hitch tubes, straight hitch bracket, and tighten loosely with two nuts M8 (G).
- Finally, pass the Hitch Pin (Y) through angled hitch bracket, Hitch Spacer (M), and straight hitch bracket, and fasten with R Pin Ø3 (N).

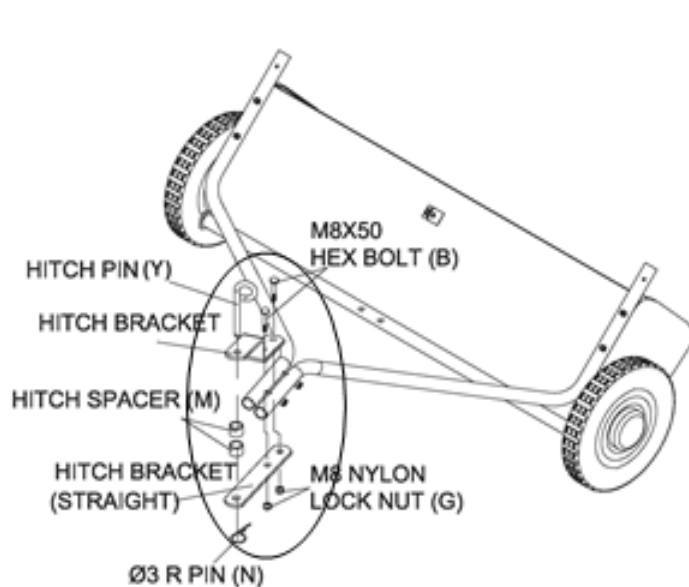

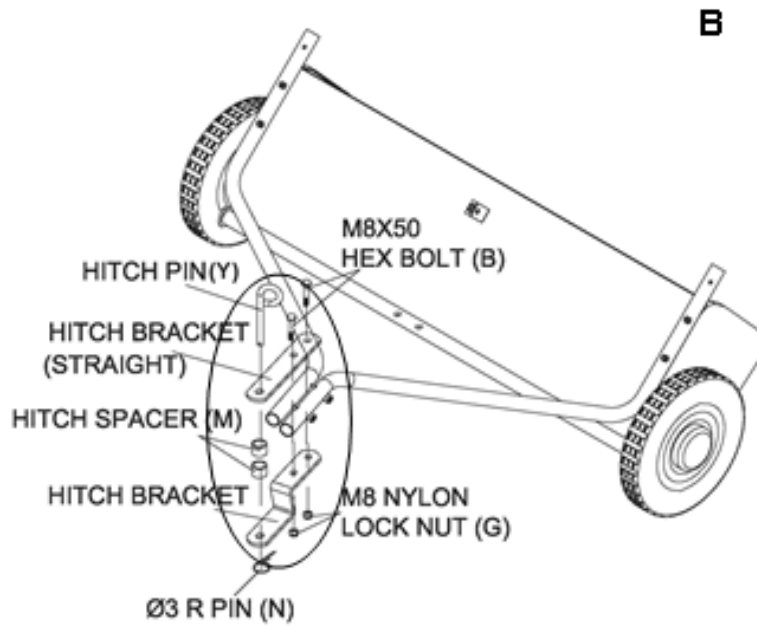

STEP 5 - SECURE

Tighten all nuts and bolts from Steps 2 through 4.

STEP 6 - ATTACH HEIGHT ADJUSTMENT HANDLE

- Mount the height adjustment handle onto the height adjustment bar. (The height adjustment bar is located outside of the sweeper housing assembly, spanning the wheels.) Use two Hex Bolts M8x40 (C) and Nylon Lock Nuts M8 (G) to firmly attach the handle assembly to the bar.
- Attach the height adjustment strap to the angle bracket (mounted in Step 1). Align the round hole in the height adjustment strap with the angle bracket. In the following order, pass Hex Bolt M8x20 (E) through the angle bracket, the adjustable pole spacer (spacer bushing), the height adjustment strap, and the Big Flat Washer Ø8 (J). Tighten securely with Nylon Lock Nut M8 (G).

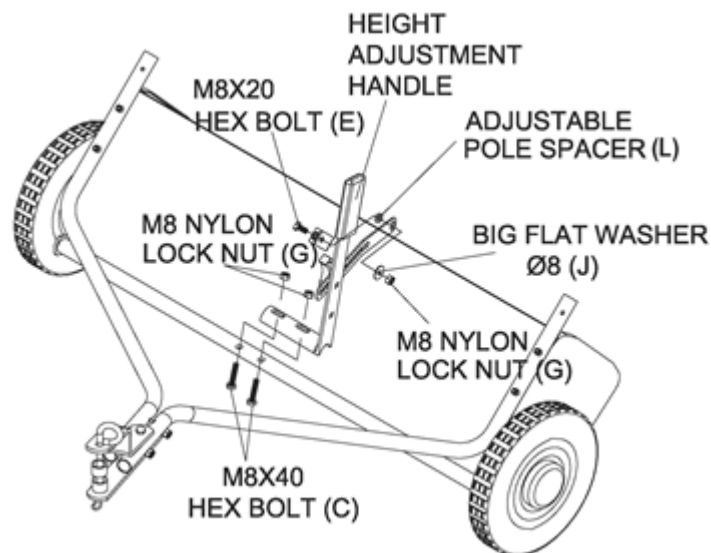

STEP 7 - MOUNT THE CONNECTING ROD TO THE SWEEPER HOUSING

Mount the connecting rod using two Hex Bolts M6x12 (I) and Nylon Lock Nut M6 (H) to the upper most mounting holes of the sweeper housing. **Tighten securely.**

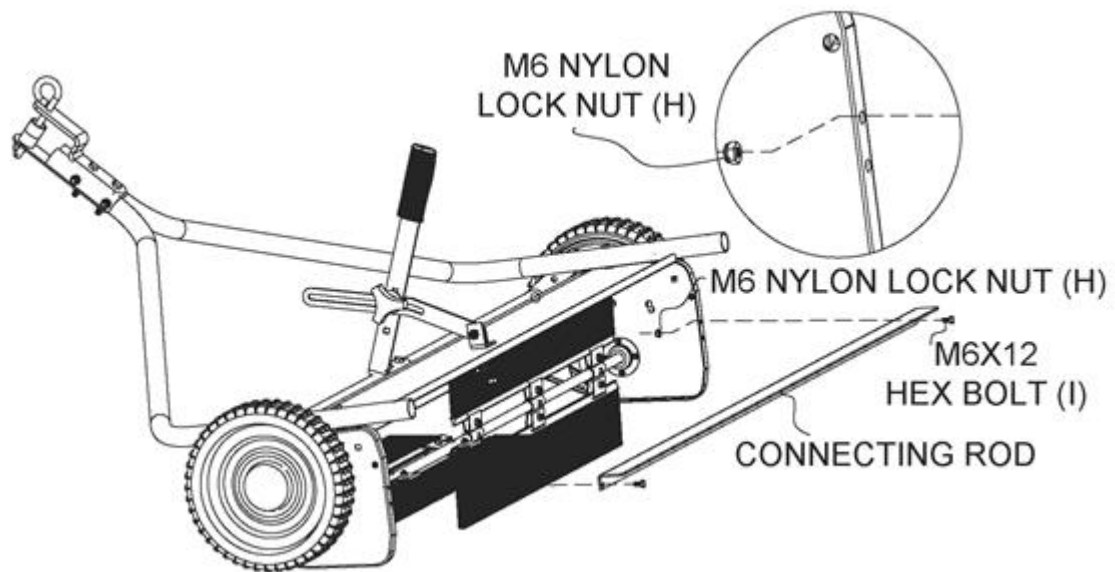

STEP 8 - ASSEMBLE HOPPER BAG

- Unroll the hopper bag and place on the ground with the nylon fabric facing up and the heavy-duty nylon floor facing the ground.
- Inspect the first rear hopper tube (part 15) and locate the brace holes. Pass the tube through the six sewn-in bag loops at the top of the inside of the hopper bag with the brace holes facing downward.
-

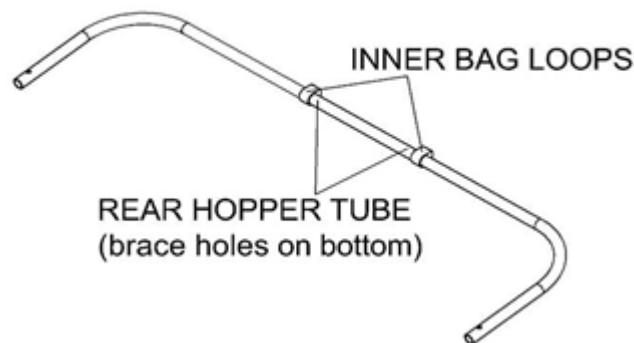

- Pass the upper hopper side tubes through the stitched sleeves on either side of the nylon fabric. On each side, insert the upper hopper side tube into the rear hopper tube, oriented downwards, and fasten plastic plugs (Z).

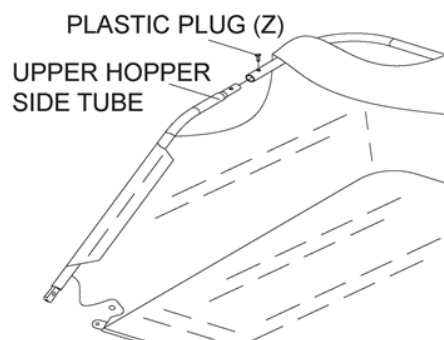

- Place the second rear hopper tube on the heavy-duty nylon floor of the hopper, with the brace holes facing upward.
- On each side, insert the lower hopper side tubes, oriented upwards, into the (lower) rear hopper tube, and fasten with plastic plugs (Z).

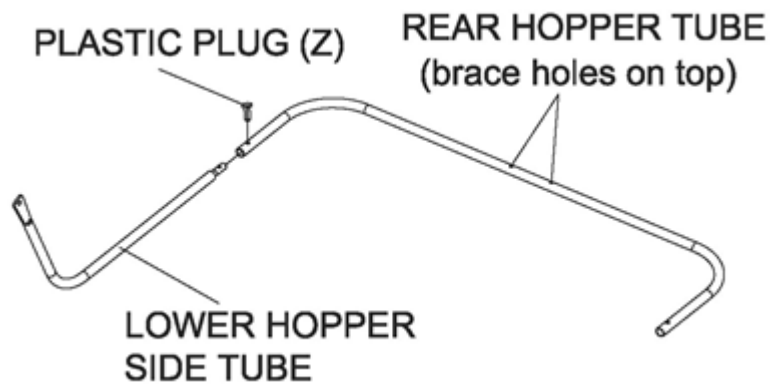

- On either side, align the ends of the upper and lower hopper side tubes and fasten these together with Clevis Pin $\varnothing 9.5 \times 25$ (P). Secure with R Pin $\varnothing 3$ (N).

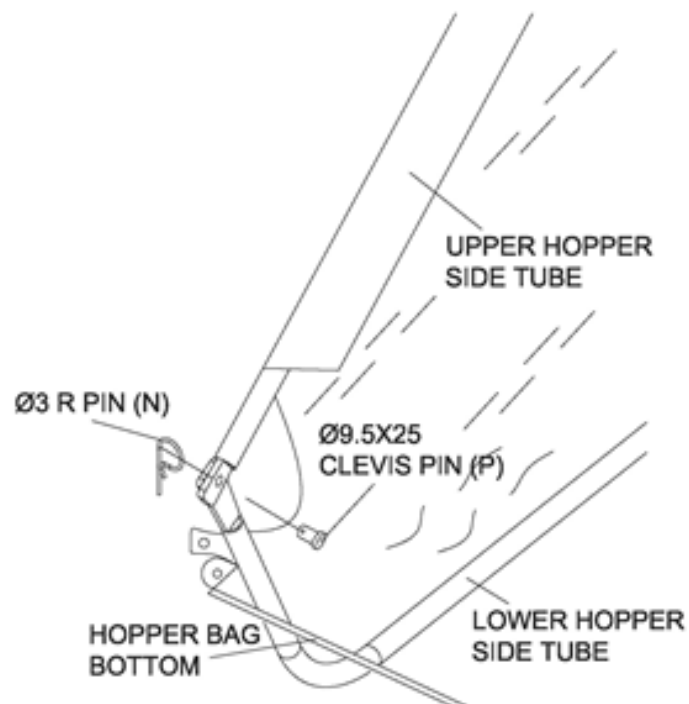

- Locate the stitched sleeve at the front edge of the bag floor. Insert the bag frame strap into the sleeve. (In some models, the bag frame strap is already inserted into the sleeve.)

- Once inserted, mount the bag frame strap onto the lower hopper side tubes using Clevis Pins $\varnothing 6 \times 37$ (Q). Secure with R Pin $\varnothing 2$ (O).

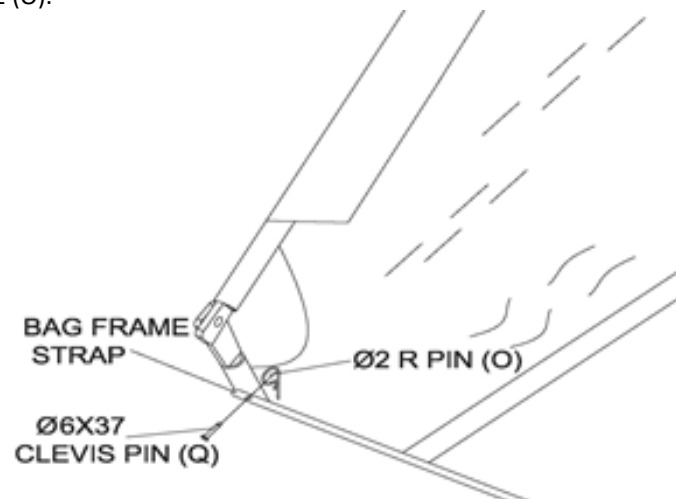

- Locate the snap buttons on the nylon fabric. Snap them into the rivets on the heavy-duty nylon floor of the hopper.

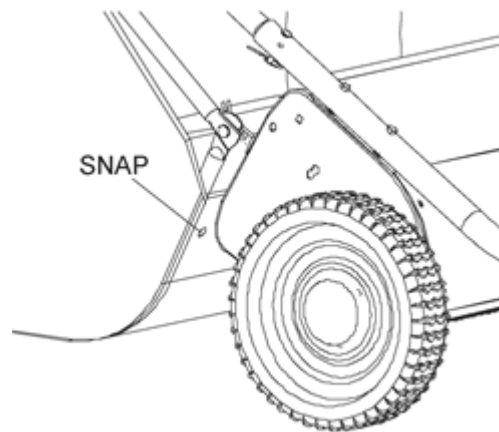

CAUTION

Do not over-stress (bend) the support rods while installing. Over stressing causes the rods to bend and lose supporting tension.

- Insert the two hopper support rods into the brace holes in the upper and lower rear hopper tubes (part 15). The hopper assembly is now complete.

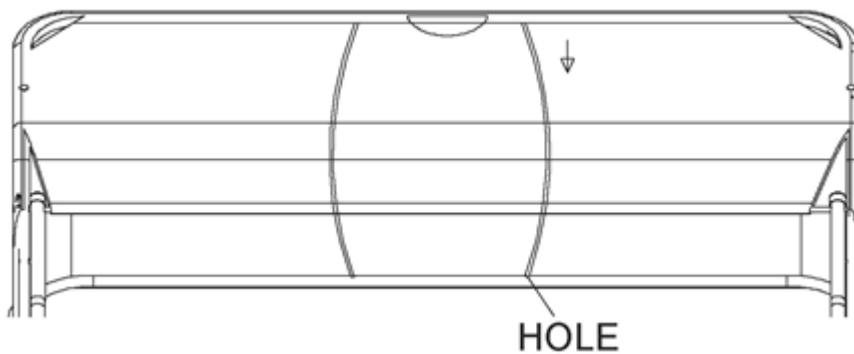

STEP 9 - ATTACH HOPPER BAG TO SWEEPER

- There are two holes in the bar of each of the upper hopper side tubes. Locate the lower hole and pierce the nylon fabric at the location of the lower hole. **Note: some models have rivets in the fabric and do not require piercing the fabric.**

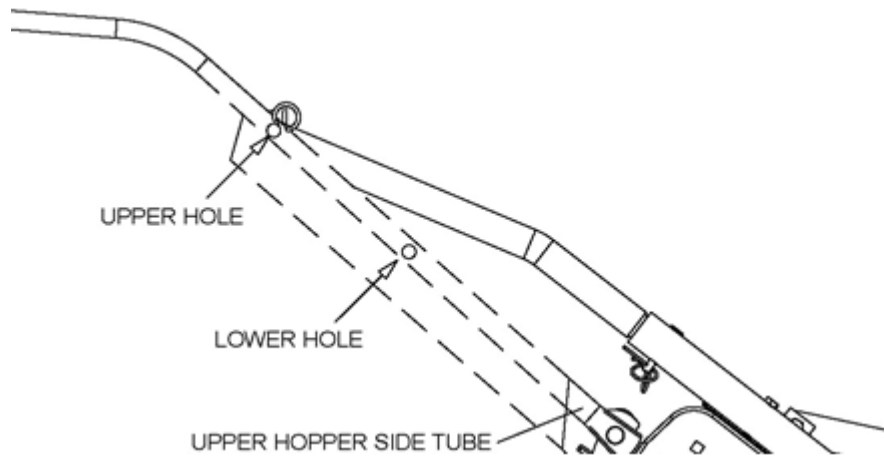

- On each side, mount a bag arm tube onto the upper hopper side tube using clevis pin $\varnothing 8 \times 59.5$ (R). Secure with R Pin $\varnothing 3$ (N). Note the orientation of the bag arm tube: cap upward, male end facing down.

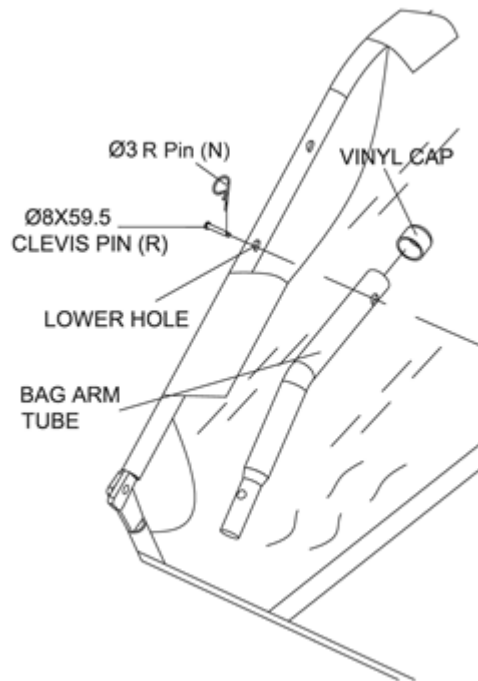

- Tie the rope to the upper hopper tube at the center of the bag frame.

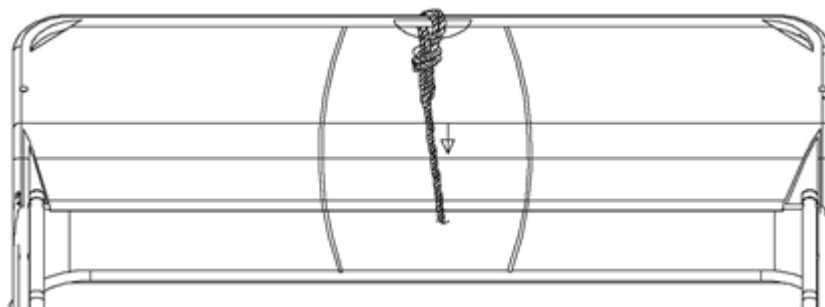

- Insert the male ends of the bag arm tubes into the hitch tubes at the back of the sweeper housing assembly (away from the hitch). Secure using Clevis Pins $\text{\O}6\text{X}37$ (Q) and R Pin $\text{\O}2$ (O).

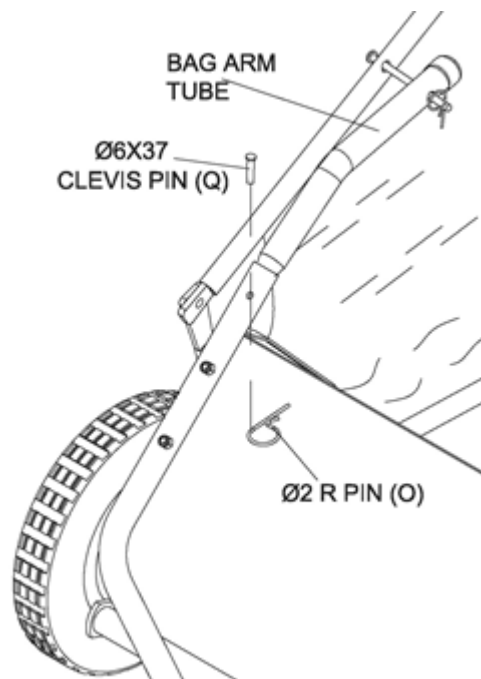

- Remove brush protection boards from inside of sweeper housing assembly.
- Check to see that all bolts are tightened adequately, and all pins are mounted securely. If all the components are securely in place, the sweeper is completely assembled and ready for use.

OPERATION



WARNING

Before using the lawn sweeper, review the instructions below and safety information. Failure to follow these instructions may result in property damage or injury to the operator or bystanders.

USING YOUR LAWN SWEEPER

Exercise caution at all times when using power equipment.

- Read this owner's manual carefully for operating and service instructions before attempting to assemble or operate this equipment. Be thoroughly familiar with the proper use of this equipment.
- Read the vehicle owner's manual and vehicle safety rules, and know how to operate the vehicle before using this equipment.
- Never allow children to operate the tractor or lawn sweeper attachment, and do not allow adults to operate without proper instructions.
- Always handle with care (wear gloves) and wear substantial footwear when operating this lawn sweeper.
- Do not allow anyone to ride or sit on lawn sweeper attachment frame or on towing vehicle.
- Keep the area of operation clear of all persons, particularly small children and also pets.
- Always begin with the transmission in first (low) gear and engine at low speed, and gradually increase speed as conditions permit.
- The vehicle braking and stability may be affected with the attachment of this equipment. Be aware of changing conditions on slopes. Refer to safety rules in the vehicle owner's manual concerning safe operation on slopes. **STAY OFF OF STEEP SLOPES.**
- **Do not exceed 5MPH**
- Always operate up and down a slope, never across the face of a slope.
- Always use caution when loading and unloading the hopper.
- Only tow with recommended vehicles (Lawn/Garden Tractors and ATVs).

- Always refer to the vehicle owner's manual for proper towing.
- Sweeper is not designed to be used with zero-turn mowers.
- Always secure and lock sweeper to the vehicle hitch before operating.
- This equipment should be operated at reduced speed on rough terrain, along creeks and ditches and on hillsides, to prevent tipping and loss of control. Do not drive too close to a creek or a ditch.
- Do not tow this equipment on a highway or any other public thoroughfare.
- Follow the maintenance instructions as outlined in this owner's manual.

ATTACH THE SWEEPER TO THE TOWING VEHICLE

On a level surface, line up the towing vehicle with the sweeper. Use the hitch pin and spacers to adjust the height of the tow hitch, as shown in the diagram. Once adjusted, insert the R Pin $\varnothing 3$ to secure the hitch pin. For best results, the hopper should be level with the ground at a minimum clearance of 5". Secure the rope to the tow vehicle.

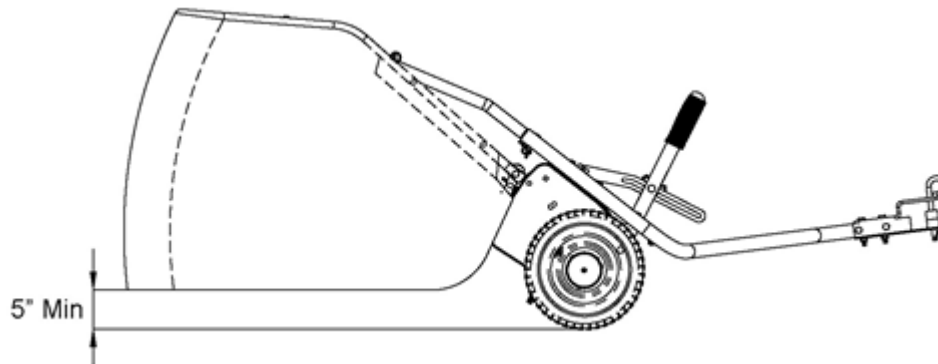
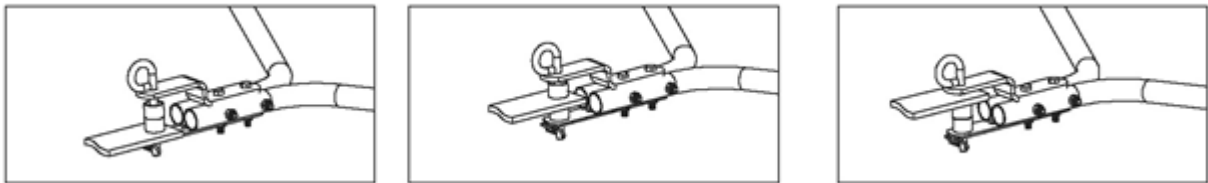

ADJUST THE HEIGHT OF THE BRUSHES

Use the height adjustment handle to set the height of the brushes. For optimal results, the brush height should be $\frac{1}{2}$ " below the tips of the grass. For sweeping other materials, you may need to adjust the height of the brushes.

TOWING THE SWEEPER

Your sweeper is designed to work at speeds of 5mph and lower. You may damage the device or experience sub-optimal results if exceeding 5mph. Your sweeper will work best on flat, smooth surfaces. If operating on a slope, always tow the sweeper up or down the surface of the hill, not sideways along the slope.

DUMPING THE HOPPER

When dumping the hopper, use the rope to pull the basket forward. Dump the hopper regularly for best performance.



CAUTION

**Always keep body parts clear from and clothing detached from the sweeper and rope.
Keep sweeper away from fire or excessive heat will cause damage to the brushes and bag.**

MAINTENANCE



WARNING

Improper maintenance and storage of the trailer may void your warranty.

- After each use clean material out of hopper.
- Rinse/dry inside and outside of the sweeper after each use.
- Periodically check all fasteners for tightness and replace any damaged fasteners.
- Check brushes for debris and keep brushes and brush shaft clean for optimal performance.
- Twice a year apply a few drops of light multipurpose oil to the brush shaft bearings.
- Annually clean and lightly lubricate all moving parts.
- Every two years remove and clean gears and apply an even coat of light synthetic grease.
- Use a glossy enamel spray paint to touch up scratched or worn painted metal surfaces.
- Never exceed the hopper load capacity rating it will damage the bag.
- Regularly grease axle and wheel bearing area or when needed.

IMPORTANT:

If a part needs replacement, only use parts that meet the manufacturer's specifications. Replacement parts that do not meet specifications may result in a safety hazard or poor operation.

LUBRICATION

The bearings in the sweeper have been pre-lubricated at the factory; however, it is recommended that a few drops of light multipurpose oil should be added to the brush shaft bearings twice a year. Also, every two years the wheels should be removed to clean the gears. After cleaning the gears, apply an even coat of light synthetic grease.

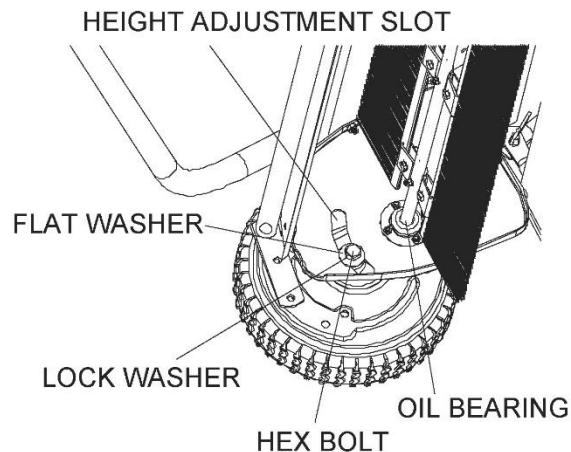

WHEEL GEARS/PAWL SERVICE

NOTE: To remove wheel, use a screwdriver to pop off hub cap, remove the lock nut and washer.

DO NOT remove both wheels at the same time. Remove one wheel at a time to prevent mixing parts or using the wrong parts as the left and right wheels and parts are different. When removing gears, carefully note the position of all washers and other parts.

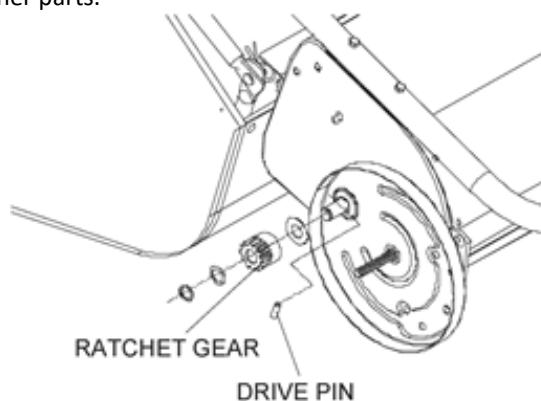

BRUSH REPLACEMENT

- Remove the hopper bag from lawn sweeper.
- Only replace one brush at a time.
- Tip the sweeper forward on housing. Do not remove the hex bolts from double brush retainers.
- Loosen hex bolts and hex lock nuts from single brush retainers. Slide brush out of retainers, making note of over-lap bristles position.
- Install new brush, make sure the over-lap bristles are in the same position as before replacement.

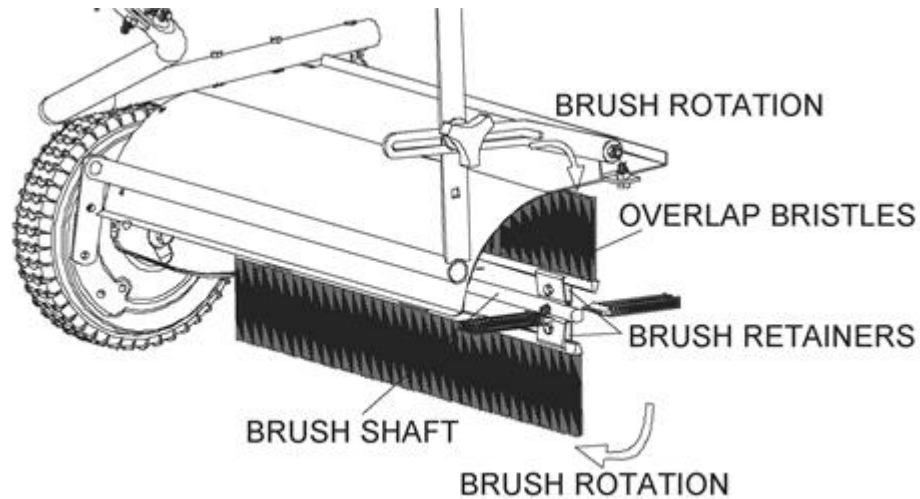

STORAGE

- Be sure to completely empty, clean and dry the sweeper hopper bag before storage.
- Failure to properly clean the sweeper and hopper may cause deterioration such as rust or mold.
- Lightly lubricate all sweeper surfaces and moving parts to protect components and prevent rust.
- Store indoors or in a protected area during severe weather and winter months.
- Sweeper can be stored compactly:
 - Pull the two bag arm tubes (#9) out of hitch tubes (#1 & #2).
 - Remove the two hopper support rods (#11).
 - Don't allow the brushes to contact the ground during storage to prevent damage.

PARTS DIAGRAM – THTLS42 (1938210001)

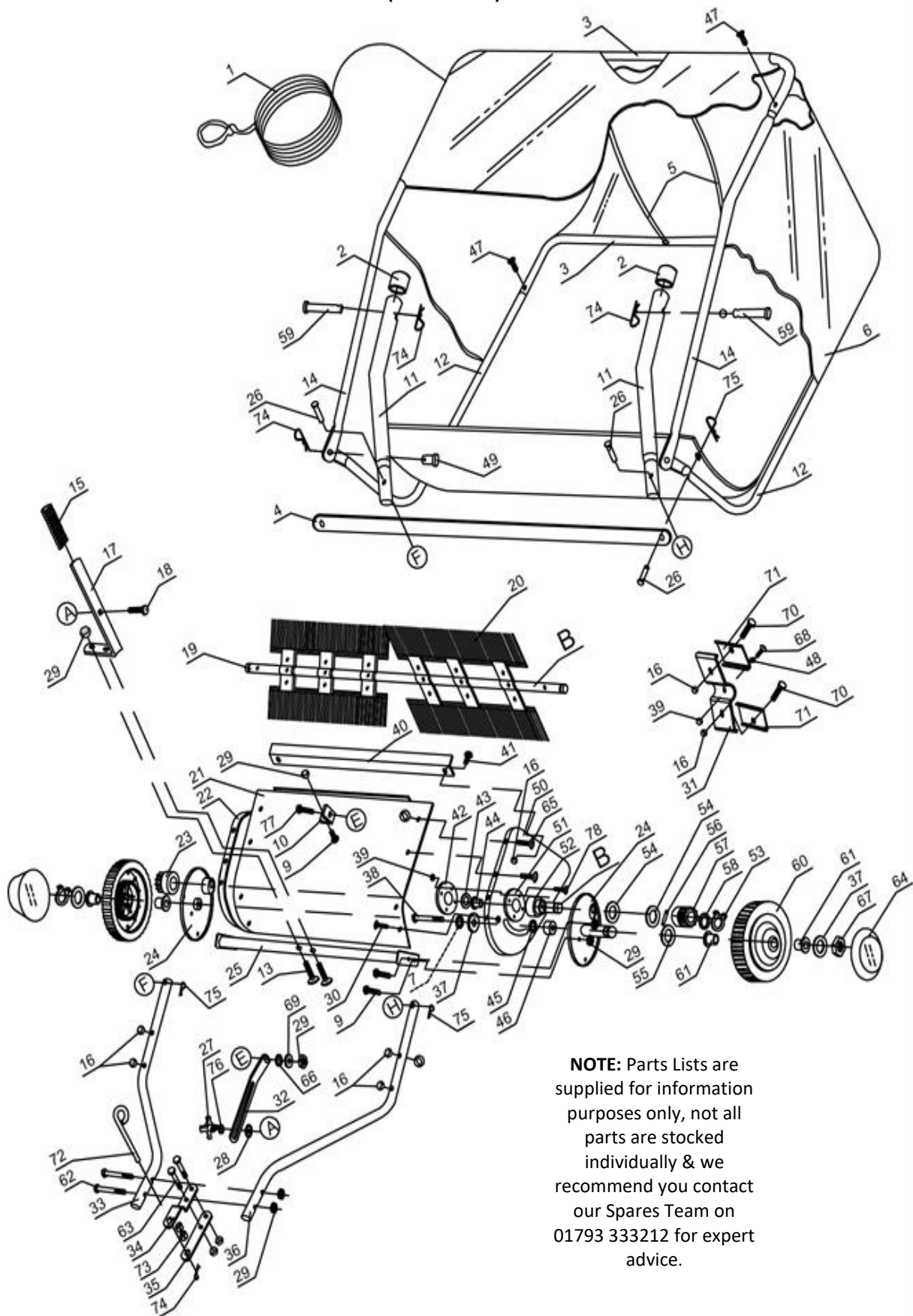

NOTE: Parts Lists are supplied for information purposes only, not all parts are stocked individually & we recommend you contact our Spares Team on 01793 333212 for expert advice.

PARTS LIST – THTD48 (1938212001) PART 1

ITEM	HANDY PART NO.	DESCRIPTION	QTY
1	TH181-1	Hopper Rope	1
2	TH181-2	Vinyl Cap	2
3	TH252-	Hopper Frame Tube (Rear)	2
4	TH252-N28000015	Bag Frame Strap	1
5	TH181-5	Hopper Support Rod	2
6	TH252-N28000039	Hopper Bag	1
7	TH252-GB93/10/DX	Lock Washer Ø10	2
9	TH181-9	Hex Bolt M8x16	5
10	TH181-10	Angle Bracket	1
11	TH181-11	Bag Arm Tube	2
12	TH252-28000006CD	Lower Hopper Frame Tube	2
13	TH181-13	Hex Bolt M8x40	2
14	TH252-	Upper Hopper Frame Tube	2
15	TH181-15	Height Adjust Grip	1
16	TH181-16	Nylon Lock Nut M6	18
17	TH181-17	Height Adjustment Handle	1
18	TH181-18	Carriage Bolt M8x30	1
19	TH252-	Brush Shaft	1
20	TH252-N28031000	Brush	4
21	TH252-N28000013	Wrapper	1
22	TH181-22	End Plate (R.H.)	1
23	TH181-23	Pinion Gear (R.H.)	1
24	TH181-24	Dust Cover Assembly	2
25	TH252-N28040000	Height Adjustment Assy	1
26	TH181-26	Clevis Pin Ø6x37	4
27	TH181-27	Wing Knob	1
28	TH121-28	External teeth Washer	1
29	TH181-29	Nylon Lock Nut M8	12
30	TH181-30	Slotted Pan Head Screw	6
31	TH181-31	Retainer Brush	6
32	TH181-32	Height Adjustment Strap	1
33	TH252-N280-00023	Hitch Tube (R.H.)	1
34	TH181-34GM	Hitch Bracket	1
35	TH181-35GM	Hitch Bracket (Straight)	1
36	TH252-N28000022	Hitch Tube (L.H.)	1
37	TH181-37	Big Flat Washer Ø10	4
38	TH181-38	Hex Bolt M10x85	2
39	TH181-39	Nylon Lock Nut M5	20

PARTS LIST – THTD48 (1938212001) PART 2

ITEM	HANDY PART NO.	DESCRIPTION	QTY
40	TH252-	Connecting Rod	1
41	TH181-41	Hex Bolt M6x12	2
42	TH181-42	Dust Cover Retainer	2
43	TH181-43	Inside Star Washer	2
44	TH181-44	Brush Shaft Bushing	2
45	TH181-45	Spacer Bushing	2
46	TH181-46	Spacer for Axle	2
47	TH181-47	Plastic Bolt	4
48	TH181-48	Star Washer Ø5	6
49	TH181-49	Clevis Pin C	2
50	TH181-50	End Plate (L.H.)	1
51	TH181-51	Special Washer	2
52	TH181-52	Bushing	2
53	TH181-53	Retaining Ring Ø15	2
54	TH181-54	Adj. Washer A	4
55	TH181-55	Adj. Washer C	2
56	TH252-940106020	Dowel Pin (Drive)	2
57	TH181-57	Pinion Gear (L.H.)	1
58	TH181-58	Adj. Washer B	2
59	TH181-59	Clevis Pin D	2
60	TH252-N28020000	Wheel & Tire Assembly	2
61	TH181-61	Wheel Bushing	4
62	TH181-62	Hex Bolt M8x65	2
63	TH181-63	Hex Bolt M8x50	2
64	TH181-64	Hub Cap	2
65	TH181-65	Hex Bolt M6x40	4
66	TH181-66	Heigh Adj. Strap Sapcer	1
67	TH181-67	Nylon Lock Nut M10	2
68	TH181-68	Hex Bolt M5x25	6
69	TH181-69	Big Flat Washer Ø8	1
70	TH181-70	Hex Bolt M6x20	12
71	TH181-71	Retainer Brush	12
72	TH181-72	Hitch Pin	1
73	TH181-73	Cotter Bushing	2
74	TH181-74	R Pin Ø3	5
75	TH181-75	R Pin Ø2	4
76	TH181-76	Big Flat Washer	1
77	TH181-77	Hex Bolt M8x20	1
78	TH252-M5X16	Slotted Pan Head Screw	8

GJ HANDY & CO LTD USER WARRANTY POLICY

Users Statement of Warranty

Each new machine is warranted against defective material or assembly of material under normal usage. The warranty applies to the original purchaser and covers faulty parts and the labour involved in replacing and repairing those parts, which are of original manufacture.

Period of Warranty

Webb (excludes Electric Handheld, Dynamic, Heritage, Legacy), Webb Pro, Sanli Engine

- a) 2 years from the original date of sale to the first domestic user.
- b) 90 days from the original date of sale to the professional/commercial user.
- c) 90 days from the original date of sale when used for hire.
- d) A reduced warranty period of 90 days applies to those items which are subject to normal wear and tear (e.g. but not limited to wheels, tyres, cutter bars, cylinders, cutting blades, blade boss, belts, cables, nylon line & spool, collection bags, spark plugs).
- e) Engines are supplied with a separate warranty to the machine. The engine manufacturers warranty statement which will be supplied within the engine instruction manual. All enquiries and warranty repairs should be discussed with the engine manufacturer or approved warranty repair dealer.
- f) 90 days from the original date of purchase for Replacement Spare Parts (unless normal wear & tear component, which are covered for 30 days).
- g) All machines' must be serviced within the first 12 months from the original date of purchase to comply with the warranty, failure to do so will invalidate the 2nd year of the warranty.

Webb Electric Handheld, Webb Dynamic, Heritage & Legacy, Handy, Mowerland, Q-Garden

- a) 1 year from the original date of sale to the first domestic user.
- b) 90 days from the original date of sale to the professional/commercial user.
- c) 90 days from the original date of sale when used for hire.
- d) A reduced warranty period of 90 days applies to those items which are subject to normal wear and tear (e.g. but not limited to wheels, tyres, cutter bars, cylinders, cutting blades, blade boss, belts, cables, nylon line & spool, collection bags, spark plugs).
- e) Engines are supplied with a separate warranty to the machine. The engine manufacturers warranty statement which will be supplied within the engine instruction manual. All enquiries and warranty repairs should be discussed with the engine manufacturer or approved warranty repair dealer.
- f) 90 days from the original date of purchase for Replacement Spare Parts (unless normal wear & tear component, which are covered for 30 days).

All warranty repairs must be undertaken by an authorised service dealer. These dealers have been accredited by GJ Handy & Co Ltd and agree to only use genuine parts and follow our repair procedures.

Not covered by this warranty

- a) The warranty policy does not cover any depreciation or damages caused by ordinary wear, rusting or corrosion, lack of correct maintenance or operation, misuse, abuse, lack of transportation or accident.
- b) The warranty policy does not cover any costs necessary for the standard periodic maintenance services instructed by the operator's manual, or service parts replacement which would include oil, filters, tyres, belts, brake linings, fuses, blades, seals and other service parts unless it can be proven that the item has evidence of faulty manufacture.
- c) The warranty policy will not cover failure or damage caused as a result of parts or accessories being modified without the written approval of GJ Handy & Co Ltd.
- d) The warranty policy will not cover the unit if non-genuine parts have been fitted and as a result damage has occurred to the unit.
- e) The warranty policy is non-transferable and is only applicable to the original purchaser.

Disclaimer

- a) This warranty is only a remedy for defect of products. GJ Handy & Co Ltd will never warranty in terms of the merchantability or the fitness for a particular purpose.
- b) No person is authorised to make any warranties, representations or promises, expressed or implied, on behalf of GJ Handy & Co Ltd, or to modify the terms conditions or limitation of this warranty policy in any way.
- c) Neither GJ Handy & Co Ltd nor any company affiliated with GJ Handy & Co Ltd shall be liable in any event or manner whatsoever for incidental or consequential damages or injuries, including, but not limited to, loss of crops, loss of profit, out of pocket expenses or profits, rental of substitute equipment or other commercial losses.

General

- a) Most warrantable failures show up within the first few weeks of use. These failures are usually straightforward and warranty assessment is relatively easy.
- b) Failures relating to cutter decks and belts need careful investigation, as the cause may not always be straightforward. Look for damage to blades and pulleys especially when the cutter belt or blade boss have snapped or cracked as this could be due to impact damage.
- c) Customers should always refer to the operator/instruction manual when any disputed problem arises, you will find most areas covered within the manual.



EC DECLARATION OF CONFORMITY

We Handy Distribution Ltd - SN3 5HY (Importer) declare that the product:

Designation: 42" (107cm) Towed Lawn Sweeper

Model(s): THTLS42

Product Number: 1938210001

Type/Serial No: As per rating label on machine

Working Width: 42" (107cm)

Complies with the following directives:

2006/42/EC – Machinery Directive

The conformity assessment procedure followed was in accordance with

EN ISO 12100:2010,

EN 349:1993+A1:2008,

EN 93:1997+A1:2009,

EN ISO 13857:2008

Notified Bodies:

ENTE CERTIFICAZIONE MACCHINE

Address(es):

Via Ca' Bella, 243 - Loc. Castello id Serravalle - 40053 Valsamoggia (BO) - ITALY

Authorised signatory & technical file holder

Date:

21/05/2019

Signature:

Name:

Mr. Simon Belcher

Position:

Chairman

Company:

Handy Distribution Ltd

Address:

Murdock Rd, Dorcan, Swindon, Wiltshire, SN3 5HY.

NOTES

**For spares or support of your handy product,
please contact us:**

Tel: 01793 333212

**Email: customerservice@handydistribution.co.uk
(Mon – Fri 8.00am to 5.30pm excl. Bank Holidays)**

To see our range of garden machinery & equipment visit:

www.thehandy.co.uk

Making gardening easier & affordable since 1938

Distributed by Handy Distribution, Murdock Road, Dorcan, Swindon, SN3 5HY