

# AQUALISA

# SIERRA™

CONCEALED/EXPOSED CONCENTRIC  
VALVE WITH ADJUSTABLE KIT

---

INSTALLATION AND USER GUIDE

---

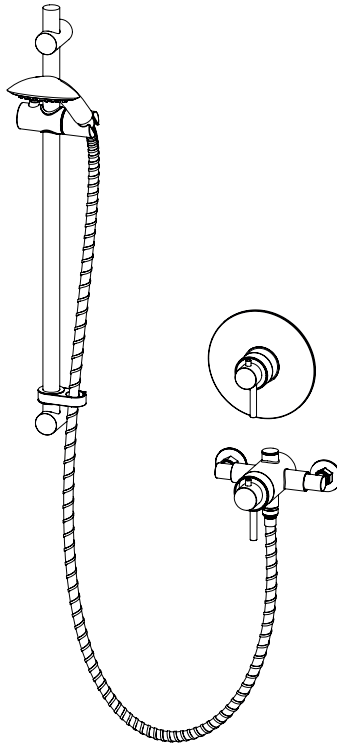

# CONTENTS

---

General Information	2
Tools Required (Tools not supplied)	2
Warranty	3
Before You Start	3
Installation Exposed	4
Installation Concealed	6
Fitting the Shower Kit	11
Cartridge Temperature Adjustment	14
Cleaning the Thermostatic Cartridge	15
User Instructions	17
General Cleaning	18
Trouble Shooting	18

## GENERAL INFORMATION

---

This product complies with EN1111.

This product must be fitted in compliance with the UK Water Supply (Fittings) Regulations. If in doubt please contact your local water authority.

## TOOLS REQUIRED (TOOLS NOT SUPPLIED)

---

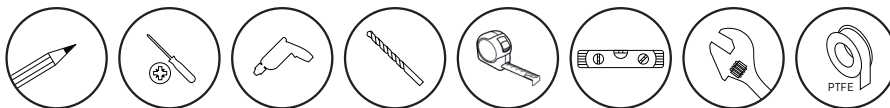

We have taken great care to ensure that this product reaches you in perfect condition. However should any parts be damaged or missing please contact your point of purchase. This does not affect your statutory rights. In addition if you require replacement parts please contact the Aqualisa customer helpline on 01959 560010 for assistance.

# WARRANTY

---

Aqualisa products are supplied complete with a 1 year guarantee that can be upgraded by registering this product with Aqualisa.

For details see: [www.aqualisa.co.uk/warranty](http://www.aqualisa.co.uk/warranty)

## BEFORE YOU START

---

This shower should be installed by a competent person in compliance with current Water Supply Regulations. For further details contact your Local Water Authority.

- a. Identify all components and check pack contents.
- b. Turn off water supplies.
- c. Suitable full bore isolation valves must be fitted to both supplies in accordance with current Water Supply Regulations and our terms of warranty. Valves must be accessible for warranty and servicing.



Before making any pipe connections all supplies **MUST** be thoroughly flushed to remove any debris.

## WATER SUPPLY REQUIREMENTS

---

Hot Water Maximum: 65°C  
Recommended 60-65°C

Cold Water Minimum: 5°C  
Recommended 10-15°C

Always maintain a 10°C difference between hot system temperature and maximum hot setting of valve.

Operating Pressure Range: Min. 0.15 bar, Max. 5.0 bar

When water pressure is higher than 5 bar a pressure reducing valve (not supplied) must be fitted before the mixer. A setting of 3 bar is recommended.

This valve is suitable for gravity stored, gravity boosted (pumped), balanced high pressure and combination boiler systems.

For gravity and gravity pumped systems use 22mm supply pipes and reduce to 15mm for connection to the shower valve.

**Pump Installation:** PUMPS MUST NOT BE FITTED DIRECTLY TO A WATER MAIN. REFER TO PUMP MANUFACTURERS INSTALLATION GUIDELINES. Ensure there is adequate flow through the pump to activate the flow switches.

**Combination boiler:** MUST have a minimum rating of 24kW (80,000 Btu) and be of the type fitted with a fully modulating gas valve.

**N.B.** Boiler performance may affect outlet temperature.

**Operating pressures:** Hot and cold supplies should be kept as even as possible in order to ensure the maximum efficiency of the mixer.

## INSTALLATION

This product is suitable for concealed, falling and rising inlet supply pipes.

### Exposed Shower Installation

1

Ensuring adequate provision to allow the water to discharge safely to waste, turn on the supplies to flush the system through. Attach pressure test equipment and pressure test the system in accordance with Water Supply Regulations.

**N.B.** Turn off the water supply following system flushing.

2

Construct suitable 15mm inlet supplies at level 150mm centres. Ensure the pipework protrudes a minimum of 100mm, measured from the intended finished wall surface.

#### Inlet water supplies

As viewed from front on:

Left = HOT

Right = COLD

Pipe centres:  $150 \pm 1$ mm

Adjustable: 145 - 155mm

Pipe tails: 18mm

From finished surface

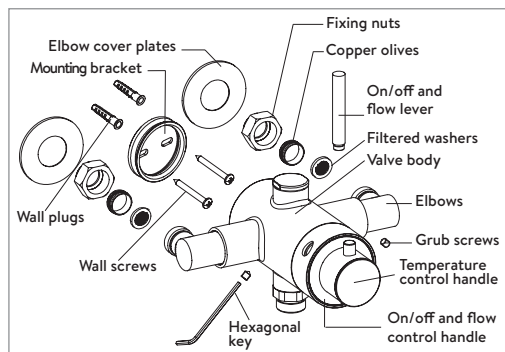

**N.B.** The inlet elbows are supplied at factory set 150mm centres. If required, the inlet centres can be adjusted by winding the elbows into the body to reduce the inlet centres, or out to increase the inlet centres.

3

Once the wall surface has been finished, flush through the pipe work prior to trimming the length of the pipes to 18mm, measured from the finished wall surface.

**N.B.** We recommend using a rotary type cutter but if a hacksaw is used, ensure the cut is straight and the pipe ends must be carefully deburred and chamfered.

**N.B.** If plastic pipe is used, tube inserts must be fitted and must not increase the diameter or extend the cut off length by more than 2mm.

4

Place valve body against the wall with elbows over the pipe tails and mark around the base where it sits on the wall. Remove valve body, place mounting bracket in centre of the **outlined valve position\*** and mark points for fixing holes.

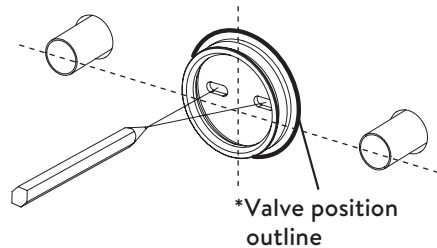

5

Important - Use appropriate fixings suitable for wall type/ construction. Drill holes to suit required fixings (Use wall plugs supplied if suitable).

6

Secure mounting bracket to the wall using the wall screws supplied (if suitable).

7

Fit the elbow cover plates, fixing nuts and copper olives over the pipe tails and insert the filtered washers into the elbows of the valve.

8

Making sure the outlet is at the bottom and that the elbows align with the pipe tails, push the valve body onto the mounting bracket, and secure with the two grub screws using the 2.5mm hexagonal key (supplied).

Securely tighten the nuts of the elbows using a suitable spanner.

9

Fit the lever to the on/off and flow control handle.

10

Turn on water supplies and check for leaks.

Refer to page 13 for shower kit installation instructions.

## Concealed Shower Installation

1

### Pre-fitting checklist

Chase out a suitable recess in the wall to receive the valve and pipework.

In most cases it will be necessary to first install a suitable sound fixing / nogging in the cavity area to secure the valve.

A hole of Ø165mm is required to install the valve and gain access to the inlet and outlet connectors.

**N.B.** The outlet connector can be repositioned to the top of the shower valve as required to suit plumbing arrangements. Simply swap with the blanking plug and ensure both are securely re-tightened.

Construct suitable pipework.

## IMPORTANT: Servicing and Maintenance access

To enable sufficient access for ease of installation, servicing and maintenance ensure:

Hot and cold feeds to the inlet elbows of the valve are from falling or rising pipe work. (i.e. Elbow connections pointing upwards or downwards).

The inlet elbows are wound in as far as possible to keep the pipe centres to a minimum.

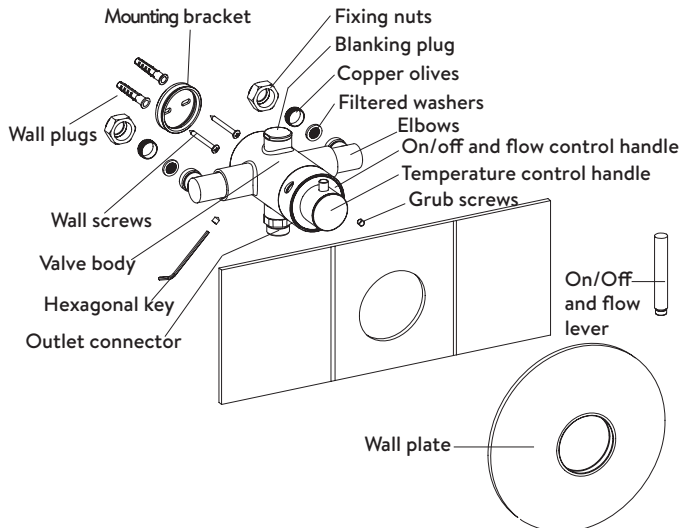
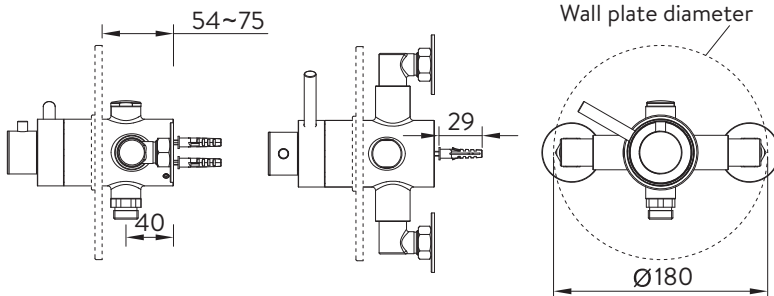

2

---

Construct hot and cold supply pipes to the proposed siting. Ensuring adequate provision to allow the water to discharge safely to waste, turn on the supplies to flush the system through. Attach pressure test equipment and pressure test the system in accordance with Water Supply Regulations.

3

---

Turn off the water supply following system flushing.

4

---

Construct suitable 15mm inlet supplies at level centres and a 15mm outlet supply pipe to the desired location for the wall outlet.

Inlet water supplies:

As viewed from front on: Left = HOT    Right = COLD

Pipe centres: Adjustable: 145\* - 155mm

Important: The inlet elbows are supplied at factory set 150mm centres. \*We strongly recommend keeping the inlet centres to a minimum by winding the elbows into the body.

Pipework for the wall outlet needs to terminate in a suitable ½” female connector (not supplied).

**N.B.** All pipework and connectors must be secured using suitable fixings.

5

---

Trim pipework to the required length. Pipe insertion depth into the elbow is 10-12mm (excluding nut and olive).

**N.B.** We recommend using a rotary type cutter but if a hacksaw is used, ensure the cut is straight and the pipe ends must be carefully deburred and chamfered.

**N.B.** If plastic pipe is used, tube inserts must be fitted and must not increase the diameter or extend the cut off length by more than 2mm.



6

Place valve body into position with elbows over the pipe tails and mark around the base where it sits on the mounting surface.

Remove valve body, place mounting bracket in centre of the **outlined valve position\*** and mark points for fixing holes.

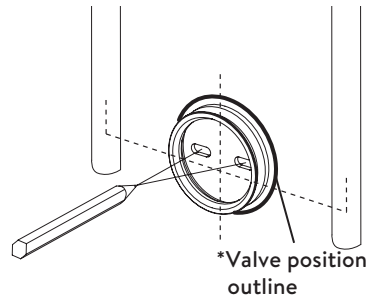

7

Important - Use suitable fixings for the mounting surface/ construction. Drill holes to suit required fixings (use wall plugs supplied if suitable).

8

Secure bracket to the mounting surface using the wall screws supplied (if suitable).

9

Fit the fixing nuts and copper olives over the pipe tails.

10

Insert the filtered washers into the elbows.

11

Making sure that the hot and cold inlet elbows align with correct supplies, feed onto the pipes and push the valve body onto the mounting bracket. Secure with the two grub screws using the 2.5mm hexagonal key (supplied).

Securely tighten the nuts of the elbows using a suitable spanner.

12

---

Using a suitable coupling connect pipework to the outlet of the valve body.

**N.B.** The outlet connector can be repositioned to the top of the shower valve as required to suit plumbing arrangements. Simply swap with the blanking plug and ensure both are securely re-tightened.

Outlet pipework needs to terminate in a suitable ½” female connector (not supplied). Refer to Shower Kit installation instructions page 11.

13

---

Turn on water supplies and check for leaks.

14

---

Install a cover panel (not supplied) or finish wall surface/tiles leaving sufficient access for future servicing and maintenance.

**N.B.** The wall plate can be used as a template for the access hole size by placing it on the valve and drawing around the plate and measuring in by 15mm to allow sufficient surface area around the hole to fit the wall plate.

15

---

When the finished wall surface is completed, fit the wall plate to the shower valve and slide up to the wall surface (use a suitable sealant as necessary). Screw the lever on to the on/off flow control handle.

## Fitting the Shower Kit - Wall Outlet

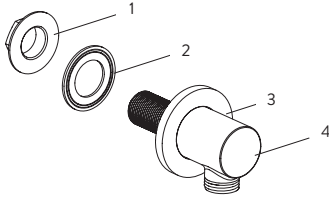
BRASS WALL OUTLET	NO.	DESCRIPTION	QTY
	1	Backnut	1
	2	Backnut Washer	1
	3	Wall Cover Plate	1
	4	Wall Outlet	1

### With rear access:

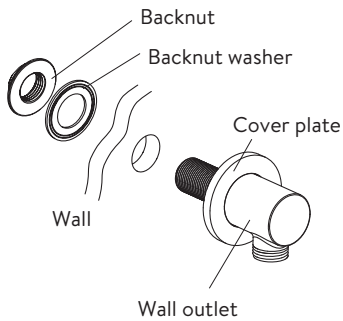

### Without rear access:

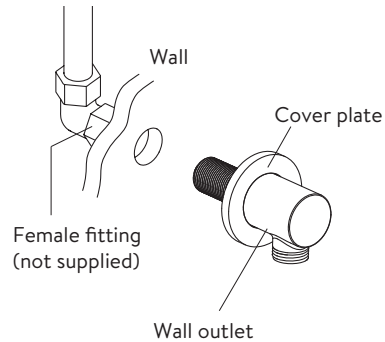

### With rear access

1

Run pipework from the shower valve to the desired location for the wall outlet ensuring it terminates in a suitable ½" female connector (not supplied). All pipework and connectors must be secured using suitable fixings.

2

Feed the wall outlet thread through a 22-28mm hole in the wall and secure with the backnut ensuring the backnut washer is fitted between the backnut and the wall, if accessible.

3

Connect the wall outlet to a suitable ½” female connector using PTFE tape or similar, to achieve a watertight seal.

4

Temporarily cap off the wall outlet, open the shower valve and check for leaks.

### **Without rear access**

1

Run pipework from the shower valve to the desired location for the wall outlet ensuring it terminates in a suitable ½” female connector (not supplied). All pipework and connectors must be secured using suitable fixings.

2

The backnut and backnut washer are not required. Wind the wall outlet thread directly into the ½” female connector (not supplied) using PTFE tape or similar, to achieve a watertight seal.

3

Temporarily cap off the wall outlet, open the shower valve and check for leaks.

## Fitting the Shower Kit - Rail Assembly

ADJUSTABLE SHOWER KIT	NO.	DESCRIPTION	QTY
	1	Wall Plug	2
	2	Upper Rail Bracket	1
	3	Short Wall Screw	1
	4	End Cap	2
	5	Handset Holder	1
	6	Handset	1
	7	Riser Rail	1
	8	Shower Hose - 1.5m	1
	9	Hose Restraint	1
	10	Lower Rail Bracket	1
	11	Long Wall Screw	1

1

The top bracket is a floating bracket and can be positioned to suit existing screw holes (if required).

Prepare two fixing points, using the fixings provided (if suitable).

**N.B.** The maximum distance between fixing points is 620mm.

2

Fit the hose restraint to the rail followed by the handset holder. The handset holder button must be depressed whilst fitting. The button must be to the left of the rail, and the holder to the right.

3

Secure the upper rail bracket into position on the finished wall surface using the short wall screw.

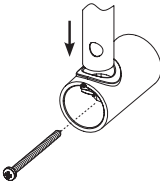
- 4 Attach the lower rail bracket onto the bottom of the rail.
- 5 Slide the rail assembly up through the upper rail bracket.
- 6 Align the small hole in the rail with the lower rail bracket. Secure the lower rail bracket to the wall, using the long wall screw.
- 7 Place the end caps into the upper and lower rail brackets and push firmly into position.
- 8 Ensuring the hose washer is in the correct position; attach the non-conical end of the hose to the wall outlet (for concealed models) or the valve body (for exposed models). Run the shower for a few seconds to clear any debris that may be present.
- 9 Pass the conical end of the shower hose through the hose restraint.
- 10 Ensuring the hose washer is in the correct position; attach the conical end of the hose to the shower head, then place the hose in the handset holder.

## CARTRIDGE TEMPERATURE ADJUSTMENT

---

This product has been factory set under balanced pressures, and a hot water supply of 65°C.

**N.B.** This product can reach temperatures in excess of 50°C.

If site conditions vary significantly from the factory conditions, it may be necessary to reset the temperature of the cartridge to enable the product

to deliver 38°C when the temperature knob is set to the 38°C position.

In this case, you can adjust the cartridge to change the outlet water temperature to suit your requirements. This can be adjusted whilst using a digital thermometer and following the below instructions.

1. Turn the temperature knob to the 38°C position.
2. Carefully unscrew and remove the temperature cover cap, loosen the screw, then remove the temperature handle.
3. Run the shower at required flow.
4. Whilst measuring the temperature of the water, turn the brass spindle until the temperature reaches 38°C.

**N.B.** For ease of turning the spindle temporarily refit the temperature handle.

5. Once 38°C is achieved, turn the shower off.
6. Refit the temperature knob by depressing the temperature override safety button and carefully pushing the knob into place with the button at the 12 o'clock position. Tighten the screw and fit the cap.

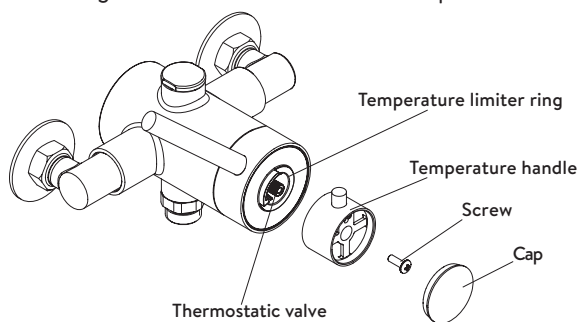

## CLEANING THE THERMOSTATIC CARTRIDGE

---

1. Before carrying out any maintenance, ensure the water supplies are isolated. Once isolated, turn the shower on to release internal pressure. If unsure contact a qualified tradesman.
2. Unscrew the temperature cover cap, loosen the screw, then remove the temperature handle. Taking note of the orientation (as it must be refitted the same way), remove the limiter ring using a pointed tool or screwdriver.

3. Push the black release tabs outward, pulling the flow handle forward at the same time (see Fig 1). Care should be taken not to break the release tabs.
4. Remove the retaining nut using a suitable spanner. Prior to removing the cartridge, take note of it's orientation as it must be refitted the same way. We suggest making markings at the 12 o'clock position on the brass spindle and the cartridge assembly.
5. For ease of removing, temporarily refit the temperature handle and pull the cartridge free from the valve body . Rinse the cartridge under cold water to remove any debris or limescale build up.
6. If necessary, replace the cartridge. A replacement cartridge can be obtained by contacting customer service on 01959 560010.
7. Refit the cartridge into the valve body – there are white tabs on the cartridge which align with grooves inside the valve body. Tighten the retaining nut using a suitable spanner.
8. Align the tabs to the holes and push the on/off and flow handle back into position and refit the temperature limiter ring and handle. Tighten the screw and refit the handle cover cap.
9. Reinststate the water supply and ensure there are no leaks.

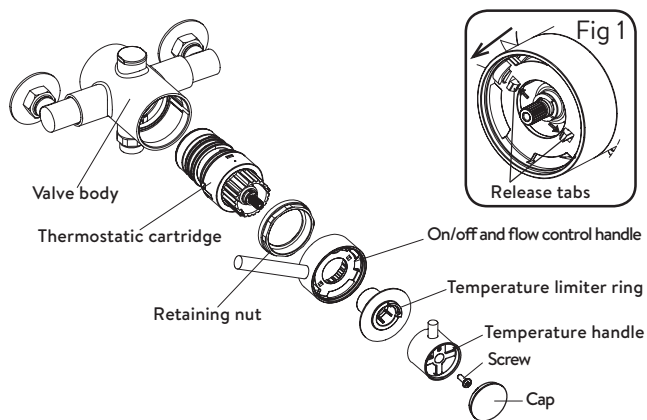



# USER INSTRUCTIONS

---

## Shower valve

The valve and fixings **MUST NOT** be used as a grab rail or means of support.

Controls - As viewed from the front:

Temperature control - Front. On / Off Flow - Rear.

To turn the shower on rotate the lever anticlockwise until the desired flow rate is achieved.

To turn the shower off, rotate the lever clockwise.

The shower is at mid-blend position when the button on the front dial is centrally at the top.

**N.B.** The mid blend temperature is dictated by the temperature of the incoming supplies.

To select a comfortable showering temperature, depress the override button and rotate the dial using the temperature markings as a guide.

For a cooler temperature - rotate clockwise. For a warmer temperature -rotate anticlockwise.

**N.B.** With all Sierra shower valves fitted to combination boiler systems, it may be necessary to adjust the flow control knob and reduce the flow to achieve a comfortable showering temperature.

## Shower head and rail system

NEVER ATTEMPT TO MAKE ANY ADJUSTMENT TO THE SHOWER HEAD BY PULLING ON THE SHOWER HOSE.

1. To select the preferred height for the shower head, depress the handset holder button to enable the slider to be moved up or down the rail.
2. Angular adjustment is made by carefully but firmly pulling forwards or pushing back the shower head towards the wall.

**N.B.** The tension of the handset holder can be adjusted with a screwdriver.

- To select the desired spray pattern rotate the shower spray plate clockwise or anti-clockwise.

### **Inlet filters**

The product is protected by inlet filter washers located in the inlet elbow connections.

## **GENERAL CLEANING**

---

Whilst modern plating techniques are used in the manufacture of these fittings, the plating will wear if not cleaned properly. The safest way to clean your product is to wipe with a soft damp cloth. Stains can be removed using washing up liquid.

**DO NOT USE ABRASIVE CLEANERS.**

### **Limescale**

Rub the nozzles of the shower head to break down scale build up. Should chemical descaling of the head become necessary, remove the shower head fully and immerse in a mild proprietary descaler.

**IT IS IMPERATIVE THAT DESCALING IS CARRIED OUT STRICTLY IN ACCORDANCE WITH THE MANUFACTURERS INSTRUCTIONS. SUBSTANCES THAT ARE NOT SUITABLE FOR PLASTICS AND ELECTROPLATED SURFACES MUST NOT BE USED.**

## **TROUBLE SHOOTING**

---

<b>Symptom</b>	<b>Possible Cause</b>	<b>Remedy</b>
Water leaking from shower head.	This is normal for a short time after turning off.	Adjust angle of shower head in holder as necessary to vary draining time. Clean shower head.
	Shower flow valve failing to close fully, possibly due to water borne debris.	Remove cartridge and check. See pages 15-16 before dismantling shower valve.
Maximum water temperature too hot or cold.	Maximum water temperature set incorrectly.	Reset maximum water temperature. See pages 14-15.

Only hot or cold water from the shower valve outlet.	Partially closed stop or service valve in water supply pipework to the shower valve.	Open stop or service valve.
	Inlet filter is partially blocked.	Clean or replace, flush through pipework before refitting.
	Inlet water supplies are reversed (hot to cold supply).	Check the connections are the correct way round. Hot on the left and cold on the right when viewed from the front. Rework pipework as necessary.
Handset holder tight/loose.	Requires adjustment.	Use cross head screwdriver in handset holder to adjust.
Control dials stiff to operate.	Debris/Scale build up.	See pages 15-16.
No flow or low flow rate and/or varying temperatures.	Check shower head, hose and filters for any blockages.	Clean as necessary. See pages 17-18.
	Partially closed stop or service valve in water supply pipework to the shower valve.	Open stop or service valve.
	Instantaneous water heater cycles on and off as the flow rate or pressure is too low.	Increase water flow rate or pressure through system. Contact the boiler manufacturer.
	Head of water is below the minimum distance required or insufficient to activate pump.	Raise the cistern or fit a universal booster pump. Refer to pump manufacturers guidelines.
	Inlet filter is partially blocked.	Clean or replace, flush through pipework before refitting.
	Hot or cold water being drawn off elsewhere causing pressure changes or instantaneous boiler temperature changes.	Do not use other water outlets when using the shower.
	Make sure the maintained inlet pressures are nominally balanced and sufficient.	See Water Supply Requirements pages 3-4.
	Airlock or partial blockage of the pipework (gravity supply only).	Flush through pipework to ensure removal of debris and any airlocks.
	No hot or cold water reaching the shower valve.	Check hot and cold feeds (the valve will shut down if either the hot or cold supply fails).
Outlet water temperature too hot/cold.	Inlet filter is partially blocked.	Check inlet filters for any blockages and clean as necessary.
	Installation conditions outside operating parameters.	See Water Supply Requirements pages 3-4. Refer to Cleaning the Thermostatic Cartridge section (page 15-16). Refer to Cartridge Temperature Adjustment (page 14-15).
	Hot water temperature is less than 10°C above the required blend temperature.	Adjust hot water temperature or wait for water to reheat if stored system is used.
	Instantaneous water heater not igniting because water flow rate is too low.	Increase water flow rate through the system. Check inlet filters and cartridge - clean or replace. See pages page 15-16. Contact the boiler manufacturer.

# AQUALISA

Aqualisa Products Limited  
The Flyers Way  
Westerham Kent TN16 1DE

Customer Helpline: 01959 560010 | Brochure Hotline: 0800 652 3669  
Website: [www.aqualisa.co.uk](http://www.aqualisa.co.uk) | Email: [enquiries@aqualisa.co.uk](mailto:enquiries@aqualisa.co.uk)  
Warranty: [www.aqualisa.co.uk/warranty](http://www.aqualisa.co.uk/warranty)

Republic of Ireland  
Sales enquiries: 01-864-3363  
Service enquiries: 01-844-3212



Please note that calls may be recorded for training and quality purposes.

The company reserves the right to alter, change or modify the product specifications without prior warning.

™ Trademark of Aqualisa Products Limited.



Part No: 704451 Issue 03 July 19