

TITAN[®]

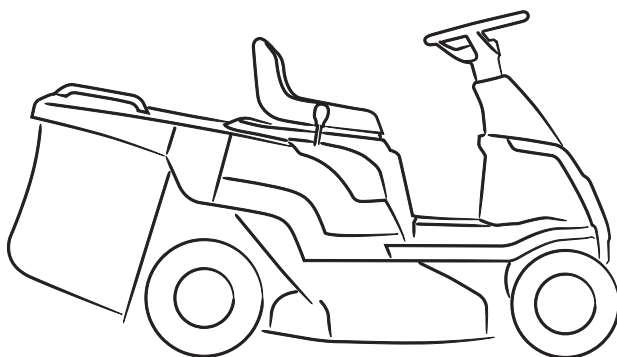

TTK550LWM

EN

**RIDE-ON LAWNMOWER WITH SEATED OPERATOR
OWNER'S MANUAL**

WARNING!

Read this manual carefully before using the machine.



Supported by



For all your Warranty,
Parts and Service needs

0800 121 6585

www.servicelink.org.uk

TITAN®

Congratulations on your purchase of a MAC ALLISTER Ride On Lawnmower. We want you to continue getting the best performance from it so this handbook includes information on safety, handling and care. Please retain this handbook in case you need to refer to any of the information in the future. Your MAC ALLISTER Ride On Lawnmower comes with a 1 year guarantee, so should it develop a fault within this period contact the Service Link helpline on 0800 121 6585.

GUARANTEE



This product has been manufactured to a high quality standard. It is guaranteed against faulty materials and workmanship for 12 months from purchase, please retain your till receipt as proof of purchase.

If the product is found to be defective within the relevant time period, we will either replace all defective parts or, at our discretion, replace the unit free of charge with the same item or items of a greater value and/or specification.

This guarantee does not cover defects caused by or resulting from:

- Misuse, abuse or neglect,
- Trade, professional or hire use,
- Repairs attempted by anyone other than our authorised repair centre (call 0800 121 6585);
- Damage caused by foreign objects, substances or accident.

This guarantee does not effect your statutory rights. B&Q plc.

Service Link



- > **What is Service Link?** Service Link is an aftersales help and advice helpline with a national network of garden machinery repair specialists.
- > **How can we help you?** Here at Service Link we can help with all your trouble shooting, warranty, parts and service needs. Call us and speak to one of our advisors and if required, visit one of our 450 centres across the UK and Ireland.
- > **How can you contact us?** In the unlikely event that this product does require our help please contact the helpline on 0800 121 6585 in the UK or 1800806149 in Rol. Lines are open Monday-Saturday 9am to 5pm and Sundays 10am to 4pm. Also find us online at www.servicelink.org.uk

Let's get **started...**

These instructions are for your safety. Please read through them thoroughly before use and retain them for future reference.



Getting **started...**

Your product
Technical **data**
Accessory list
Safety **instructions**
Unpacking and assembly



In more detail...

Operation
Care and maintenance
Troubleshooting
Recycling **and disposal**
EC declaration of conformity

Your product

IDENTIFICATION OF THE MACHINE

The identification label located under the seat has the essential data of each machine. The serial number (6) must be quoted when you require technical assistance or spare parts.

1. Acoustic power level
2. CE conformity marking
3. Year of manufacture
4. Operating engine power and speed
5. Type of machine
6. Serial number
7. Weight in kg
8. Name and address of Manufacturer
9. Type of transmission (if indicated)
10. Article code

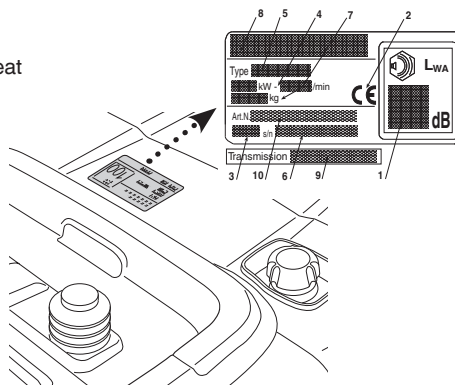

Write the serial number of your machine (6) here.

The example of the Declaration of Conformity is provided on the penultimate page of the manual.

IDENTIFICATION OF MAIN COMPONENTS

The machine is composed of a series of main components that have the following functions:

11. **Cutting-means assembly:** this is the casing that houses the rotating cutting means.
12. **Cutting means:** these are what cut the grass; the fins at the ends help convey the cut grass towards the collector channel.
13. **Collector channel:** this is the part connecting the Cutting-means assembly to the grass catcher.
14. **Grass catcher:** as well as collecting the grass cuttings, this is also a safety element that stops any objects drawn up by the cutting devices from being hurled away from the machine.
15. **Side discharge chute (if provided):** prevents any objects collected by the cutting means from being hurled away by the machine.
16. **Engine:** this moves the cutting means and drives the wheels. Its specifications and regulations for use are described in a specific manual.
17. **Battery:** provides the energy for starting the engine. Its specifications and regulations for use are described in a specific manual.
18. **Driving seat:** this is where the machine operator sits. It has a sensor connected to safety devices for detecting the presence of the operator.
19. **Warning and safety labels:** these give reminders on the main regulations for working in safety.

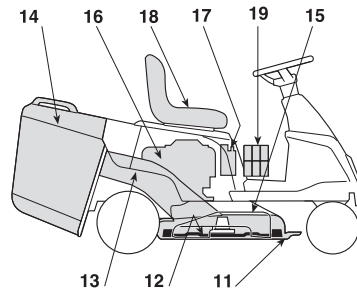

Technical data

Electrical system	12 V
Battery	7.2 Ah
Front tyres	11 x 4.00-4"
or	13 x 5.00-6"
Rear tyres	13 x 5.00-6"
or	15 x 5.50-6"
Front tyre pressure	
tyres 11 x 4.00-4"	1.5 bar
tyres 13 x 5.00-6"	1.5 bar
Rear tyre pressure	
tyres 13 x 5.00-6"	1.5 bar
tyres 15 x 5.50-6"	1.0 bar
Overall weight	120 - 135 kg
Inside turning circle (minimum diameter of uncut grass)	1.55 m
Cutting height	
tyres 11" - 13"	30 - 64 mm
tyres 13" - 15"	30 - 76 mm
Cutting width	66 cm
Grass-Catcher capacity	140 litres
Cutting means code	184109505/0

Maximum noise and vibration levels ¹⁾

Operator ear noise	
pressure level	db(A) 87
- Measurement uncertainty ...	db(A) 0.89
Measured	
acoustic output level	db(A) 98
- Measurement uncertainty ...	db(A) 0.54
Guaranteed	
acoustic output level	db(A) 98
Vibration level in the	
driver's seat	m/s ² 2.94
- Measurement uncertainty ..	m/s ² 1.91
Steering wheel vibration	
level	m/s ² 7.76
- Measurement uncertainty ..	m/s ² 2.16

¹⁾ Indicative values: effective values can be found in the "Declaration of Conformity".

Mechanical transmission

- **Tyres 11"-13"**
Forward speed (approximate)
in Forward gear 1.4 - 5.5 km/h
in Reverse 1.7 km/h
- **Tyres 13"-15"**
Forward speed (approximate)
in Forward gear 1.5 - 6.2 km/h
in Reverse 2.0 km/h

Hydrostatic transmission

- **Tyres 11"-13"**
Forward speed (approximate)
in Forward gear 0 - 5.6 km/h
in Reverse 0 - 2.7 km/h
- **Tyres 13"-15"**
Forward speed (approximate)
in Forward gear 0 - 6.2 km/h
in Reverse 0 - 3.0 km/h

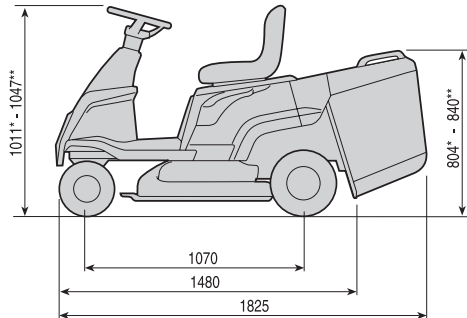
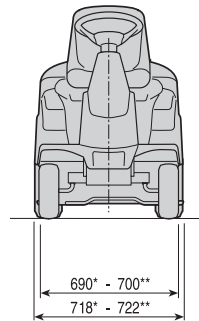

Accessory list (Available separately)

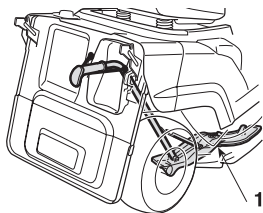

1. KIT FOR "MULCHING"

It chops the grass cuttings finely and leaves them on the lawn, instead of collecting them in the grass catcher.

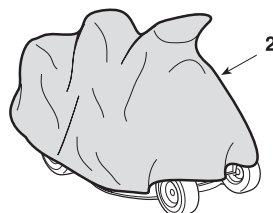

2. CLOTH COVER

Protects the machine from dust when not in use.

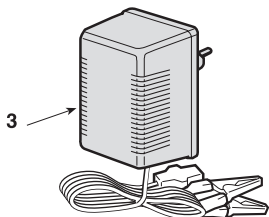

3. MAINTENANCE BATTERY CHARGER

This keeps the battery in good working order.

Safety instructions

SAFETY DECALS

Your machine should be used with due care and attention. Therefore, labels have been placed on the machine to remind you pictorially of the main precautions to take during use. These labels are to be considered an integral part of the machine. If a label should fall off or become illegible, contact your Retailer to replace it. Their meaning is explained below.



- 1** **Warning:** Read the instructions before operating the machine.



- 2** **Warning:** disconnect the key and read the instructions before carrying out any maintenance or repair work.



- 3** **Danger! Ejected objects:** Keep bystanders away.



- 4** **Danger! Machine rollover:** Do not use this machine on slopes greater than 10°.



- 5** **Danger! Dismemberment:** Make sure that children stay clear of the machine all the time when engine is running.



- 6** **Danger of cutting yourself:** Cutting means in motion. Do not put hands or feet near or under the opening of the cutting means housing.

General safety

DESCRIPTION OF THE MACHINE AND ITS RANGE OF USE

This machine is a garden tool and precisely a ride-on lawnmower with seated operator. The machine is equipped with an engine which drives a cutting unit protected by a casing, as well as a transmission unit that moves the machine.

The operator is able to operate the machine and use the main controls, always seated in the operator's position.

The devices fitted on the machine stop the engine and the cutting means within a few seconds, should the operator behave in a manner that does not comply with the necessary safety precautions.

Intended use

This machine was designed and built to cut grass.

The use of special attachments provided for by the Manufacturer as original equipment or which may be purchased separately, allows this work to be done in various operating modes, illustrated in this manual or the instructions that accompany the single attachments.

Likewise, the intended use can be extended to include other functions by applying supplementary attachments (if provided for by the Manufacturer), abiding by the restrictions and conditions indicated in the instructions accompanying the attachment.

User types

This machine is intended for use by consumers, i.e. non-professional operators. The machine is intended for "DIY" use only.

Improper use

Any other usage not in keeping with the above-mentioned ones may be hazardous and harm persons and/or damage things. Examples of improper use may include, but are not limited to:

- transporting people, children or animals on the machine or on a trailer;
- use of the machine for riding over unstable, slippery, icy, stony, rough, marshy ground or puddles that do not allow the consistency of the ground to be assessed;
- using the cutting means on surfaces other than grass.
- use of the machine for leaf or debris collection;

Improper use of the machine will invalidate the warranty, relieve the Manufacturer from all liabilities, and the user will consequently be liable for all and any damage or injury to himself or others.



Additional safety

HOW TO READ THE MANUAL

The manual describes several machine models that can mainly differ in:

- type of transmission: with mechanical gear-change or with hydrostatic continuous speed adjustment. The models with hydrostatic transmission are identified by the word “HY-DRO” on the identification label;
- the inclusion of components or attachments which are not widely available;
- special equipment fitted.

The symbol “” highlights all the differences in usage and is followed by the indication of the version to which it refers.

The symbol “” refers to another part of the manual where further information can be found.

Some paragraphs in the manual contain important information regarding safety and operation and are emphasized in this manner:

NOTE or **IMPORTANT**

These give details or further information on what has already been said, and aims to prevent damage to the machine.

 WARNING! *Non-observance will result in the risk of injury to oneself or others.*

 DANGER! *Non-observance will result in the risk of serious injury or death to oneself or others.*

NOTE *Whenever reference is made to a position on the machine “front”, “back”, “left” or “right” hand side, this is determined from where the operator is seated.*

IMPORTANT *For all operations regarding the use and maintenance of the engine or the battery not described in this manual, refer to the relevant manuals which form an integral part of all the documentation supplied with the machine.*

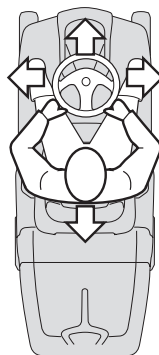

SAFETY REGULATIONS

 WARNING! *Read carefully before using the machine.*

A) TRAINING

- 1) **WARNING!** Read these instructions carefully before operating the machine. Become acquainted with the controls and the proper use of the machine. Learn how to stop the engine quickly. Failure to follow the warnings and instructions may result in fire and/or serious injury. Save all warnings and instructions for future reference.
- 2) Never allow children or persons unfamiliar with these instructions to use the machine. Local laws can restrict the minimum age of the operator.
- 3) Never mow while people, especially children, or pets are nearby.

- 4) Never use the machine if the user is tired or unwell, or has taken medicine, drugs, alcohol or any substances which may slow his reflexes and compromise his judgement.
- 5) Bear in mind that the operator or user is responsible for accidents or unexpected events occurring to other people or their property. It is the user's responsibility to assess the potential risk of the area where work is to be carried out, and to take all the necessary precautions to ensure his own safety and that of others, particularly on slopes or rough, slippery and unstable ground.
- 6) If the machine is sold or lent to others, make sure that the operator looks over the user instructions contained in this manual.
- 7) Do not allow children or other passengers to ride on the machine as they could fall off and injure themselves or compromise safe driving by the operator.
- 8) The machine operator must follow the driving instructions carefully and, in particular:
- Avoid distractions and maintain concentration whilst working;
 - Bear in mind that control of a machine sliding on a slope will not be regained by the application of the brake. The main reasons for loss of control are:
 - Insufficient wheel grip;
 - Excessive speed;
 - Inadequate braking;
 - Type of machine unsuitable for its task;
 - Lack of awareness of the effect of ground conditions, especially slopes;
 - Incorrect use as a towing machine.
- 9) The machine is supplied with a series of micro-switches and safety devices which must never be tampered with or removed; this will invalidate the warranty and relieve the manufacturer from all responsibility. Always check that the safety devices are working properly before using the machine.

B) PRELIMINARY OPERATIONS

- 1) While using the machine, always wear anti-slip and resistant work footwear and long pants. Do not operate the machine when barefoot or wearing open sandals. Avoid wearing chains, bracelets, clothing that is loose fitting or has hanging cords or ties. Tie hair back if it is long. Always wear protective earplugs.
- 2) Thoroughly inspect the entire work area and remove anything that could be thrown by the machine or damage the cutting-means assembly or engine (stones, branches, iron wire, bones, etc.).
- 3) **WARNING: DANGER!** Petrol is highly flammable.
- Store the fuel in special containers;
 - add fuel, using a funnel, only outdoors; do not smoke during this operation and each time fuel is handled;
 - Top-up with fuel before igniting the engine; never remove the tank cap or add fuel while the engine is running or when it is hot;
 - if you have spilled some fuel, do not attempt to ignite the engine but move the machine away from the area of spillage and avoid creating any source of ignition until the fuel has evaporated and fuel vapours have dissipated:
 - Always put the tank and fuel container caps back on and tighten well;
- 4) Replace faulty silencers.
- 5) Before using the machine, check its general condition and in particular: the appearance of the cutting means, and check that the screws and cutting-means assembly are not worn or damaged. Replace the entire cutting means and all damaged or worn screws to preserve balance. Any repairs must be done at a specialised centre.
- 6) Check the battery status regularly, and replace it if there is any damage to the casing, cover or terminals.
- 7) Before starting work, always fit the exit guards (grass catcher, side discharge guard or rear discharge guard).

C) DURING USE

- 1) Do not operate the engine in a confined space where dangerous carbon monoxide fumes can develop. All ignition operations have to be effected in an open or well-ventilated area. Always remember that exhaust fumes are toxic.
- 2) Work only in daylight or with good artificial light in good visibility conditions. Keep persons, children and animals away from the working area.
- 3) If possible, avoid mowing wet grass. Avoid working in the rain and when there is a risk of a thunderstorm risk. Do not use the machine in bad weather conditions, especially when there is risk of lightning.
- 4) Before igniting the engine, disengage the cutting means or the power socket and put the gear in neutral.
- 5) Pay special attention when approaching obstacles that could compromise visibility.
- 6) Engage the parking brake when parking the machine.
- 7) The machine must not be used on slopes of over 10° (17%), regardless of the mowing direction.
- 8) Remember there is no such thing as a "safe" slope. Driving on grass slopes requires particular care. To prevent overturning or loss of control over the machine:
 - Do not stop or start suddenly when going up or downhill;
 - Engage the drive slowly and always keep the machine in transmission, especially when travelling downhill;
 - Machine speeds should be kept low on slopes and during tight turns;
 - Watch out for humps, hollows and other hidden hazards;
 - Never mow across the face of the slope. Lawns on a slope have to be mowed moving up and down and never across them. When changing direction, take great care that the wheels facing the slope do not hit any obstacles (such as stones, branches, roots, etc.) that may cause the machine to slide sideways, tip over or make you lose control.

Reduce speed before any change of direction on slopes, and always apply the parking brake before leaving the machine at a standstill and unattended.
- 10) Be very careful near ravines, ditches or embankments. The machine could overturn if a wheel slides over the edge or if the earth gives way.
- 11) Pay maximum attention when working in reverse gear. Look behind you to make sure there are no obstacles before and during operations in reverse gear.
- 12) Use care when pulling loads or using heavy equipment:
 - Use approved drawbar hitch points only when towing;
 - Limit loads to those you can safely control;
 - Do not turn sharply. Take care when reversing;
 - Use counterweight(s) or wheel weights whenever advised in the instructions manual.
- 13) Disengage the cutting means or the power socket when crossing areas with no grass, when moving to or from areas that require mowing, and move the cutting-means assembly to its highest position.
- 14) Pay attention to traffic when using the machine near roads.
- 15) **WARNING!** The machine has not been approved for use on public roads. It must be used (as indicated by the highway code) in private areas closed to traffic.
- 16) Never operate the machine with damaged guards or without the grass catcher, side discharge guards or rear discharge guards.
- 17) Never place your hands and feet near or under rotating parts. Keep away from the discharge opening.
- 18) Do not leave the machine stationary on high grass with the engine running to avoid the risk of starting a fire.
- 19) When using the attachments, never direct the opening towards people.
- 20) Use manufacturer-recommended attachments only.
- 21) Don't use the machine if the attachments/tools are not installed in their seats.
- 22) Pay attention when using the grass catcher and attachments that can alter the stability of the machine, especially on slopes.
- 23) Do not change the engine settings or over-rev the engine.

- 24) Do not touch the engine parts as they get very hot when running. Danger of burns.
- 25) Disengage the cutting means or power socket, put in neutral and engage the parking brake, turn off the engine and remove the ignition key (checking that all moving parts are completely stationary):
- Whenever the machine is left unattended or the operator dismounts from the driving seat:
 - Before clearing blockages or unclogging the discharge chute;
 - Before checking, cleaning or working on the machine;
 - After striking a foreign object. Inspect the machine for damage and make repairs before using it again.
- 26) Disengage the cutting means or the power socket and switch off the engine (making sure that all moving parts are stationary):
- Before refuelling;
 - Whenever you remove or reattach the grass catcher;
 - Whenever you remove or reattach the side discharge chute;
 - Before adjusting the cutting height, if this operation cannot be performed from the driving seat.
- 27) Disengage the cutting device or the power socket during transport and whenever it is not in use.
- 28) Reduce the throttle setting before stopping the engine. Shut off the fuel supply on completing the work, following the instructions in the engine manual.
- 29) Pay attention to cutting means assemblies with more than one cutting means, as a rotating cutting means can trigger the rotation of the others,
- 30) **WARNING** – If something breaks or an accident occurs whilst working, turn off the engine immediately and move the machine away to prevent further damage; if an accident occurs with injuries or third parties are injured, carry out the first aid measures most suitable for the situation immediately and contact the medical authorities for any necessary health care. Carefully remove any debris that might cause damage or harm persons or animals should it not be seen.
- 31) **WARNING** - The noise and vibration levels shown in these instructions are the maximum levels for use of the machine. The use of an unbalanced cutting means, excessive speed of movement, or lack of maintenance have a significant influence on noise emissions and vibrations. Consequently, it is necessary to take preventive steps to eliminate possible damage due to high levels of noise and stress from vibration. Maintain the machine well, wear ear protection devices, and take breaks while working.

D) MAINTENANCE AND STORAGE

- 1) **WARNING!** - Before cleaning or doing maintenance work, take out the ignition key and read the relevant instructions. Wear proper clothing and protective gloves whenever your hands are at risk.
- 2) **WARNING!** – Never use the machine with worn or damaged parts. Faulty or worn-out parts must always be replaced and not repaired. Use original spare parts only: the use of non-original and/or incorrectly fitted parts will jeopardize the safety of the machine, may cause accidents or personal injuries for which the Manufacturer is under no circumstance liable or responsible.
- 3) Any adjustments or maintenance operations not described in this manual must be carried out by your Dealer or a specialized Service Centre with the necessary knowledge and equipment to ensure that the work is done correctly maintaining the machine's original safety level. Any operations performed in unauthorized centres or by unqualified persons will totally invalidate the Warranty and all obligations and responsibilities of the Manufacturer.
- 4) After each use, remove the ignition key and check for damage.
- 5) Keep all nuts, bolts and screws tight to be sure the equipment is in safe working condition. Routine maintenance is essential for safety and for maintaining a high performance level.

- 6) Check that the cutting means screws are properly tightened on a regular basis.
- 7) Wear work gloves when handling, disassembling and reassembling all cutting means.
- 8) Keep the cutting means well balanced during sharpening. All works on the cutting means (disassembly, sharpening, balancing, reassembly and/or replacing) are demanding jobs that require special skills as well as special tools. For safety reasons, these jobs are best carried out at a specialised centre.
- 9) Check that the brakes work properly on a regular basis. It is vital for brakes to undergo regular maintenance and, where necessary, repair work.
- 10) Check the side discharge guard, the rear discharge guard, the grass catcher and the intake grille frequently. Replace them if they are damaged.
- 11) Replace any instruction or warning message stickers, if damaged.
- 12) When the machine is to be stored or left unattended, lower the cutting-means assembly.
- 13) Store the machine out of the reach of children.
- 14) Do not store the machine with fuel in the tank in an area where the fuel vapours could reach an open flame, a spark or a strong heat source.
- 15) Allow the engine to cool down before storing in any enclosure.
- 16) To reduce fire hazards, keep the engine, silencer, battery compartment and petrol storage area free of grass, leaves, or excessive grease. Always empty the grass catcher and do not leave containers full of cut grass inside storage areas.
- 17) To reduce fire hazards, check there are no oil and/or fuel leaks on a regular basis.
- 18) If the fuel tank has to be emptied, this should be done outdoors once the engine has cooled down.
- 19) Never leave the keys in the ignition or within reach of children or unauthorised persons. Always remove the ignition key before doing any maintenance.

E) TRANSPORT

- 1) **WARNING!** - If the machine must be transported on a truck or trailer, use ramps with suitable resistance, width and length. Load the machine with the engine switched off, without a driver and pushed by an adequate number of people. During transport, close the fuel stopcock (if fitted), lower the cutting-means assembly or attachment, engage the parking brake and fasten the machine securely with ropes or chains to the hauling device.

F) ENVIRONMENTAL PROTECTION

- 1) Environmental protection should be a priority of considerable importance when using the machine, for the benefit of both social coexistence and the environment in which we live. Try not to cause any disturbance to the surrounding area.
- 2) Scrupulously comply with local regulations and provisions for the disposal of packaging, oils, petrol, filters, damaged parts or any elements which have a strong impact on the environment; this waste must not be disposed of as normal waste, it must be separated and taken to specified waste disposal centres where the material will be recycled.
- 3) Scrupulously comply with local regulations for the disposal of waste materials after mowing.
- 4) At the time of decommissioning, do not pollute the environment with the machine, but hand it over to a disposal centre, in accordance with the local laws in force.

Unpacking and assembly

For storage and transport purposes, some components of the machine are not installed in the factory and have to be assembled after unpacking. Follow the instructions below.

IMPORTANT *The machine is supplied without engine oil or fuel. Before starting up the engine, fill with oil and fuel following the instructions given in the engine manual.*

⚠ WARNING! *Unpacking and completing the assembly should be done on a flat and stable surface, with enough space for moving the machine and its packaging, always making use of suitable equipment.*

UNPACKING

When unpacking the machine, take care to gather all individual parts and fittings, and do not damage the cutting-means assembly when taking the machine off the pallet.

The standard packaging contains:

- the machine;
- dashboard cover;
- steering wheel column caster;
- the steering wheel;
- the seat;
- cutting means engagement control lever extension;
- the grass catcher components;
- the lower part of the back plate;
- "mulching" attachment components (if provided);
- the side discharge chute (if provided);
- equipment to be used to complete assembly of the various machine components (in separate bags for each use);
 - a battery charger (if provided);
 - 2 starter keys;
 - a spare 10 A fuse, to be kept in case of necessity.
- Instructions manual and machine documents.

NOTE *To avoid damaging the cutting-means assembly when getting the machine down from the pallet, take it to the maximum height and be very careful.*

Hydrostatic transmission

- To make it easier to get the machine off the pallet and to move it, the rear drive disengage lever should be put in position «B» ( page 22, section 23.).

Disposal of the packaging should be done in accordance with the local regulations in force.

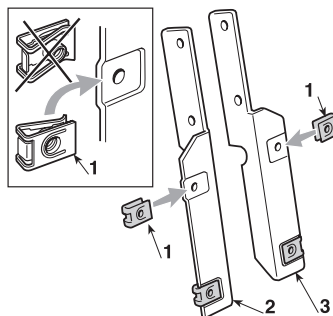

FITTING THE REAR PLATE

- Use equipment marked "A".

Apply plates (1) to the two supporting brackets (2) and (3), as shown in the figure.

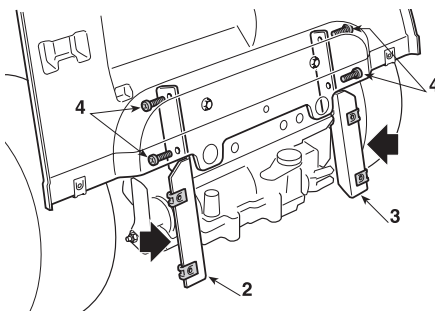

Screw (4) the two brackets (2) and (3) to the chassis supports, taking care they are in the correct right and left positions.

Mount the lower part (5) of the rear plate and screw (6) it to the lower brackets without tightening the screws completely.

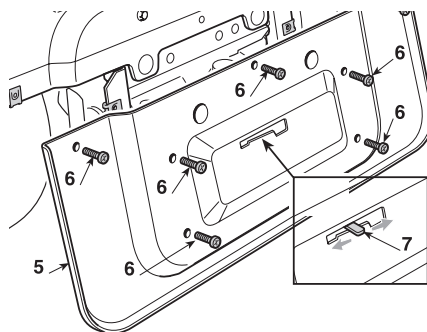

Hydrostatic transmission

- – Make sure the release lever (7) is inserted in the rear plate groove correctly and that it runs freely.

Tighten screws (6).

FITTING THE DASHBOARD AND STEERING WHEEL

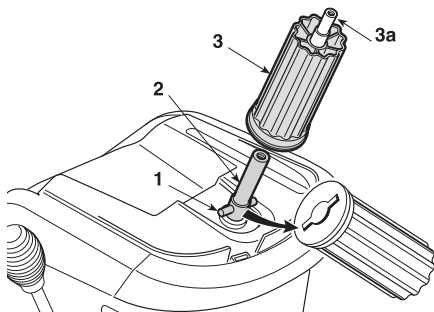

- Use equipment marked "B".

Put the machine on a flat surface and straighten the front wheels.

Fit the caster (3) on the steering column (2), making sure the plug (1) is correctly fitted into the caster seat.

Fit the steering column extension (3a) in the hole in the caster (3).

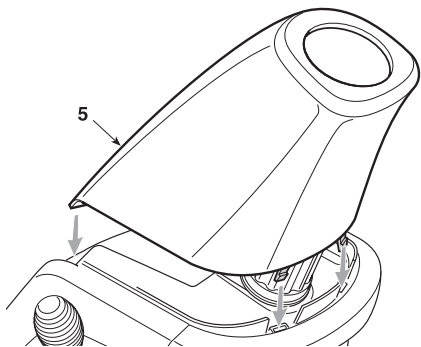

Fit the dashboard cover (5) making sure all fastenings click into their respective housings correctly.

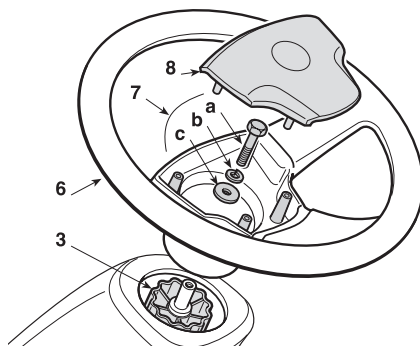

Fit the steering wheel (6) onto the caster (3) with all the spokes directed towards the seat. Fit the steering wheel fastening it with the screws (7a/b/c) supplied, in the indicated order.

Fit the steering wheel cover (8) clicking the three fasteners into place.

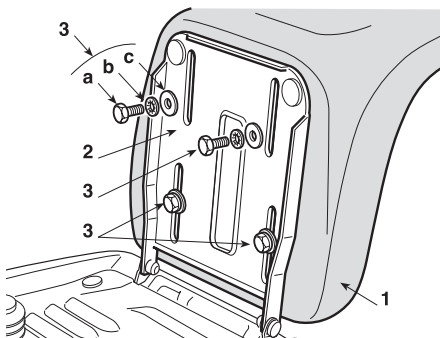

FITTING THE SEAT

- Use equipment marked "C".

Fit the seat (1) onto the plate (2) using the screws (3a/b/c).

ASSEMBLY OF THE CUTTING MEANS ENGAGEMENT CONTROL LEVER EXTENSION (Fig. 3.4)

- Use equipment marked "C".

Tighten the knob (1) on the extension (2), then screw the extension (2) onto the end of the lever (3).

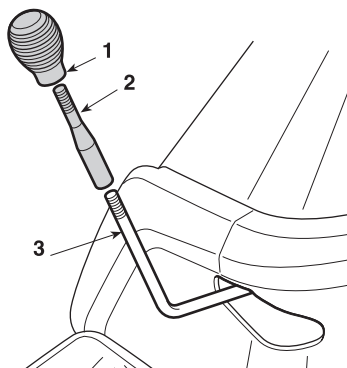

CONNECTING THE BATTERY

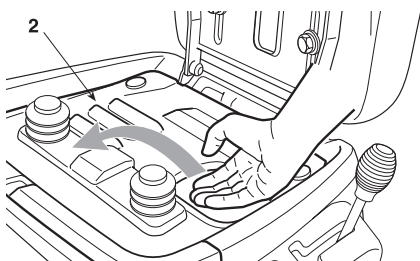

Using the connector (6), charge the battery following instructions in the booklet, then put the cover (2) back.

The battery (1) is located under the seat and can be reached by moving the cover (2). Connect the battery connector (3) to the machine connector (4) and arrange the wire (5) so that it is held firmly in place (7).

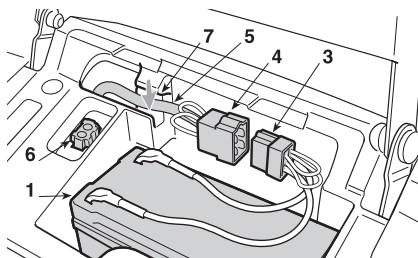

ASSEMBLING THE GRASS CATCHER

- Use equipment marked “D”.

Fit the grass catcher following the sequences illustrated in the figures.

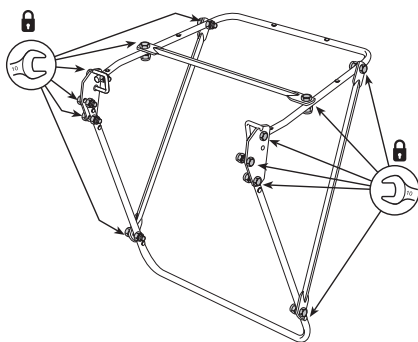
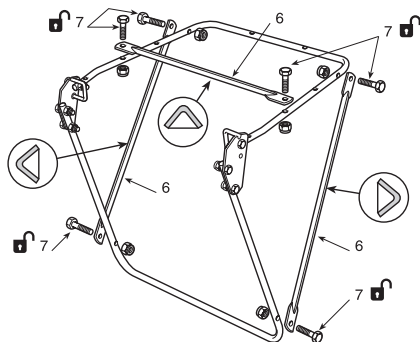
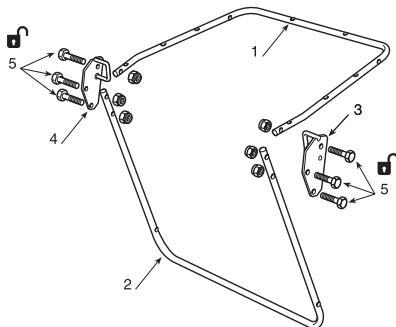
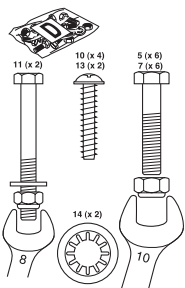

Getting started...

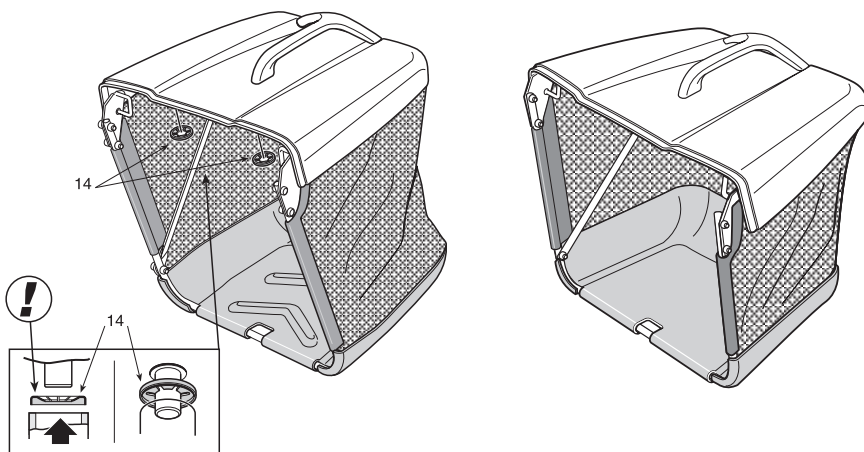
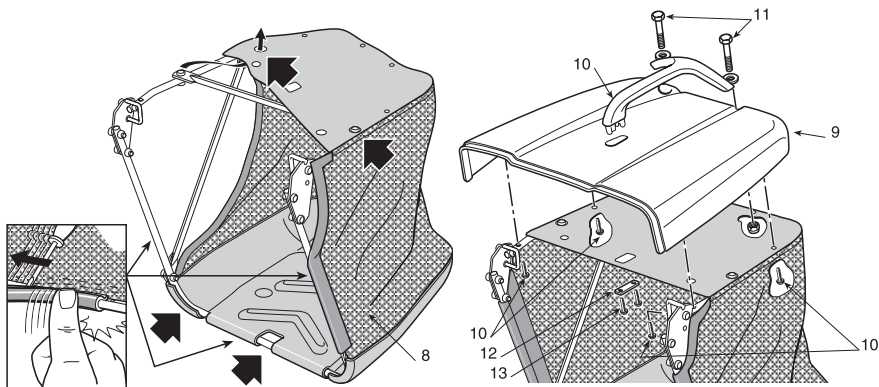

FITTING THE "MULCHING" ATTACHMENT (if provided)

- Use equipment marked "E".

Fit the handle (1) on the deflector cap (2) using the pin (3) pushing it to the end with a hammer. Insert an end of the spring (4) in the deflector cap (2) opening and fasten it with the pin (5) inserted in the specific deflector cap (2) seat (6).

Insert the other end of the spring (4) in the widest part of the hook (7).

Using a screwdriver, fasten the narrowest part of the hook (7) to the hole in the handle (1).

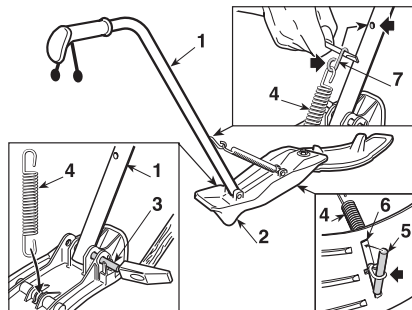



**In more
detail...**

Operation

Care and maintenance

Troubleshooting

Service Link

EC declaration of conformity

In more detail...

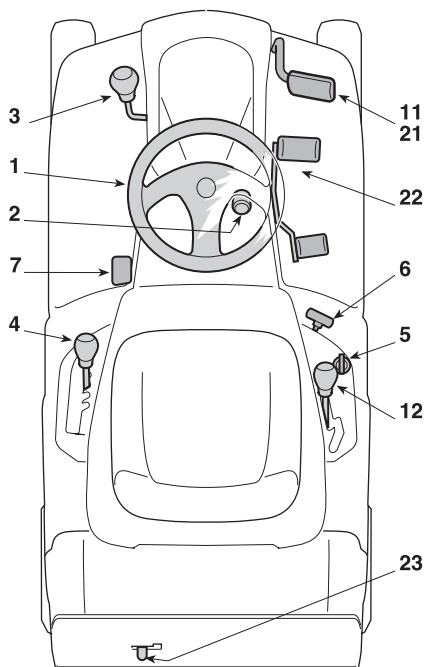

1. STEERING WHEEL

Turns the front wheels.

2. PARKING BRAKE

This lever stops the machine from moving when it has been parked. There are two positions:

«A» = Brake disengaged

«B» = Brake engaged

- The brake is applied by pressing the pedal right down (11 or 21) and moving the lever to position «B». When you take your foot off the pedal it will be blocked by the lever in the lowered position.
- To disengage the parking brake, press the pedal (11 or 21). The lever will return to position «A».

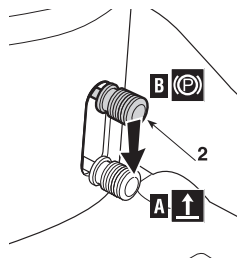

3. CUTTING MEANS ENGAGE AND BRAKE CONTROLS

This lever has two positions, as shown on the plate:

↗ Position «A» = Cutting means disengaged

↖ Position «B» = Cutting means engaged

- If you engage the cutting means without taking the necessary safety precautions, the engine shuts down and cannot be restarted.

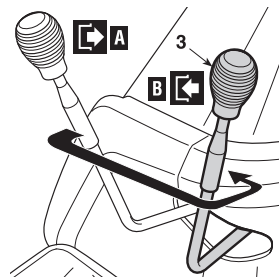

- In disengaging the cutting means (Pos. «A»), a brake is simultaneously activated which stops their rotation within five seconds.

4. CUTTING HEIGHT ADJUSTMENT LEVER

This lever has several positions so the cut can be regulated at various heights.

- To go from one position to another, move the lever sideways and put it back in one of the stop notches.

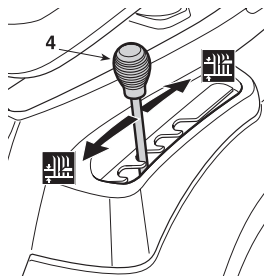

5. KEY IGNITION SWITCH

This key operated control has three positions:

- «OFF» everything is switched off;
- I «ON» activates all parts;
- 🔑 «START» engages the starter motor.

- On being released at the «START» position, the key will automatically return to «ON».

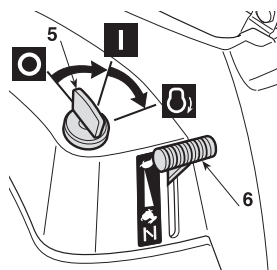

6. THROTTLE LEVER

Regulates the engine's r.p.m. The positions are indicated on the plate showing the following symbols:

- 🔧 «CHOKE» ((if provided) cold start
- 🐢 «SLOW» for minimum engine speed
- 🐘 «VELOCE» for maximum engine speed

- The «CHOKE» position (if provided) enriches the mixture so it must only be used for the time necessary for cold starts.
- When moving from one area to another, put the lever in a position between «SLOW» and «FAST».
- When cutting, shift into «FAST».

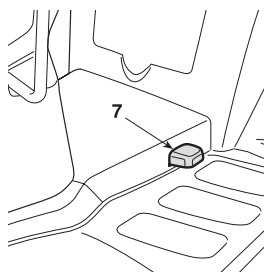

7. REVERSE GEAR CUTTING CONSENT PEDAL

By pressing and holding the pedal down, it is possible to switch to reverse gear with the cutting means engaged without causing the engine to stop.

Mechanical transmission

11. CLUTCH / BRAKE PEDAL

This pedal has two functions: during the first part of its travel it acts as a clutch, engaging and disengaging drive to the wheels, and in the second part it acts as a brake on the rear wheels.

IMPORTANT Do not keep the pedal half way between clutch engagement or disengagement, as this can cause overheating and damage the transmission belt.

NOTE When the machine is in movement, keep your foot off the pedal.

12. SPEED CHANGE LEVER

This lever has six positions for the four forward speeds, the neutral position «N», and reverse «R».

To go from one speed to another, press the pedal (4.11) halfway and shift the lever as shown on the label.

⚠ WARNING! Reverse must be engaged when the machine has stopped.

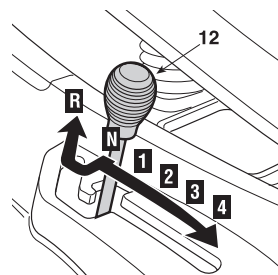
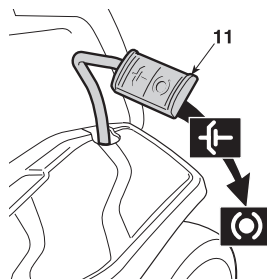

Hydrostatic transmission

21. BRAKE PEDAL

This pedal works the brake on the rear wheels.

22. DRIVE PEDAL

This pedal engages drive in the wheels and controls the machine's forward and reverse speed.

- To engage forward gear just press it in the «F» direction with the tip of your foot, noting that increasing the pressure on the pedal progressively increases the speed of the machine.
- Reverse is engaged by pressing the pedal with the heel towards «R».
- The pedal automatically goes into neutral «N» when released.

⚠ WARNING! Reverse must be engaged when the machine has stopped.

NOTE If the drive pedal is used, whether forwards or reverse, when the parking brake (4.2) is engaged, the engine stops.

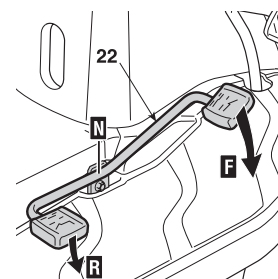
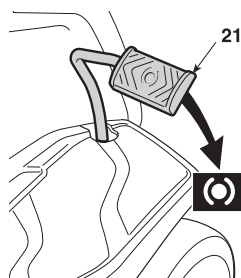

23. HYDROSTATIC TRANSMISSION DISENGAGEMENT LEVER

This lever has two positions as shown on the label:

«A» = Transmission engaged: for all uses, when moving and during cutting;

«B» = Transmission disengaged: this makes it much easier to move the machine by hand, with the engine turned off.

IMPORTANT To avoid damaging the transmission unit, this operation must be carried out only when the engine has stopped with the pedal (4.22) at position «N».

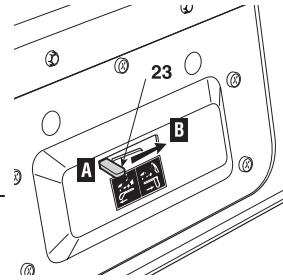

SAFETY RECOMMENDATIONS

⚠ WARNING! *This machine must not be used on slopes steeper than 10° (17%) (👉 Using on Slopes).*

IMPORTANT *All the references relating to the positions of controls are described from page 20 to page 23.*

WHY THE SAFETY DEVICES CUT IN

The safety devices work in two ways:

- they prevent the engine from starting if all the safety requirements have not been met;
- by stopping the engine if even just one of the safety requirements is lacking.

a) To start the engine, it is necessary that:

- the transmission is in "neutral";
- all the cutting means are correctly in place;
- the operator is seated.

b) The engine stops when:

- the operator leaves his seat;
- the grass catcher is lifted when the cutting means are engaged;
- the cutting means is engaged without the grass catcher in place;
- the parking brake is engaged without disengaging the cutting means (👉 page 20, n. 2 - 3).
- the drive pedal is activated with the parking brake on (👉 page 20, n. 22 - 2).

DIRECTIONS BEFORE STARTING

Before starting to mow, it is necessary to carry out several checks and operations to ensure you can work efficiently and in maximum safety.

Seat adjustment

To change the seat position, loosen the four fixing bolts (1) and slide it along the slots. Once you have found the right position, tighten the four screws (1) thoroughly.

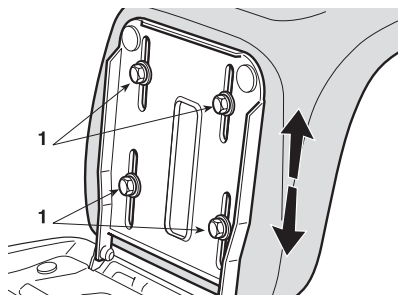

Tyre pressure

Having the right tyre pressure is the main condition for ensuring that the cutting-means assembly is horizontal and mows evenly.

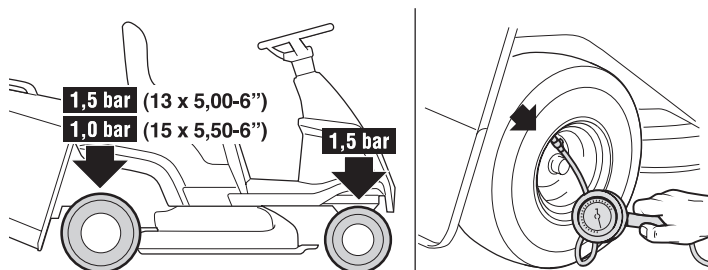

Unscrew the valve caps and connect a compressed air line with a gauge to the valves and adjust the pressure to the indicated values.

Filling with oil and fuel

NOTE *The type of oil and fuel to use is given in the engine manual.*

To reach the oil dipstick, turn the seat over and remove the cover underneath. With the engine off, check the oil level. According to the instructions in the engine manual, this must be between the MIN and MAX marks on the dipstick.

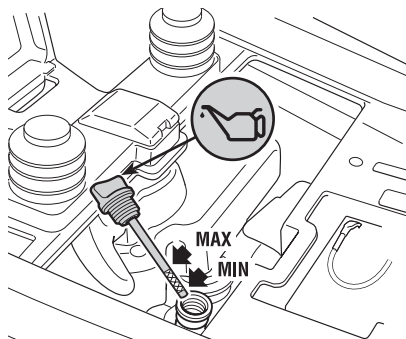

Refuel using a funnel, but do not completely fill the tank.

⚠ DANGER! *Refuelling should be carried out in an open or well-ventilated area with engine stopped. Always remember that petrol fumes are inflammable. DO NOT TAKE A NAKED FLAME TO THE TANK'S OPENING IN ORDER TO SEE THE TANK'S CONTENTS AND DO NOT SMOKE WHEN REFUELLING.*

IMPORTANT *Do not drip petrol onto the plastic parts to avoid ruining them. In the event of accidental leaks, rinse immediately with water. The warranty does not cover for damage to plastic parts of the bodywork or the engine caused by petrol.*



Preparing the machine and fitting the exit guards (grass catcher or side discharge chute)

NOTE This machine lets you mow lawns in different ways, according to the fitted attachments. The attachments mentioned here may be part of the original equipment or may be purchased afterwards. Before starting work, prepare the machine based on how the lawn is to be mowed. **DO THIS WHEN THE ENGINE IS OFF.**

⚠ WARNING! Never use the machine without having fitted the exit guards!

• Preparation for grass cutting and collection in the grass catcher

Hook on the grass catcher (1) inserting the two connections (2) in the holes on the two supports (3).

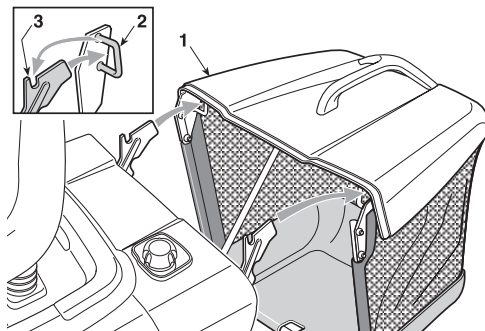

• Preparation for mowing and mulching

Make sure that the inside of the cutting-means assembly is sufficiently clean and free of grass and mud deposits that might hinder inserting the deflector cap for mulching.

Move the cutting-means assembly to the maximum height position and insert the mulching attachment (1) on the discharge opening, pushing it down inside the collector channel until it stops.

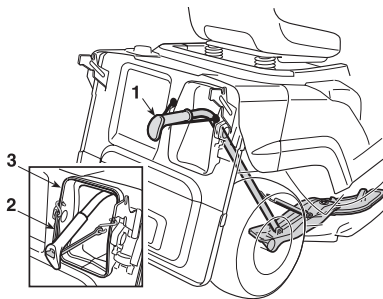

Fasten the two elastic tie-rods (2) to the two holes on the sides of the collector channel (3). Then put the grass catcher on as indicated above.

• Preparation for mowing and grass side discharge

Lift the safety lever (1) and the side discharge guard (2). Fasten the side discharge chute (3) and lower the guard (2), making sure it stays well fastened to the chute protrusions (3a).

The side discharge chute is properly fitted if the two arrows are aligned (4).

Then put the grass catcher on as indicated above.

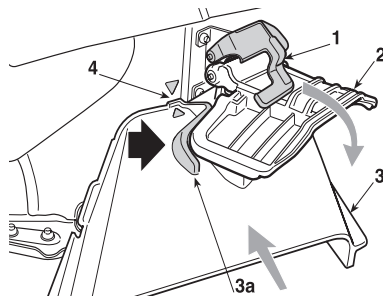

Checking machine safety and efficiency

1. Check that the safety devices function as described (☛ Why the safety devices cut in).
2. Check that the brake is in perfect working order.
3. Do not start mowing if the cutting means vibrate or if you are unsure whether they are sharp enough. Always remember that:
 - A badly sharpened cutting means pulls at the grass and causes the lawn to turn yellow.
 - A loose cutting means causes abnormal vibrations and can be dangerous.

⚠ WARNING! *Do not use the machine if you are unsure whether it is working safely or efficiently. If in doubt, contact your Dealer immediately to make the necessary checks or repairs.*

USING THE MACHINE

Starting

To start the engine:

- open the fuel stopcock (1) (if fitted) accessing it from the left rear wheel compartment;
- put the transmission into neutral («N») (☛ page 22, n. 12 - 22);
- disengage the cutting means (☛ page 20, n. 3);
- apply the parking brake on sloping ground;
- for a cold start, use the choke (☛ page 21, n. 6);
- if the engine is already warm or without a choke, just put the lever between «SLOW» and «FAST»;
- insert the ignition key (☛ page 21, n. 5) and turn to «ON» to make electrical contact, then turn to «START» to start the engine;
- release the ignition key once the engine has started.

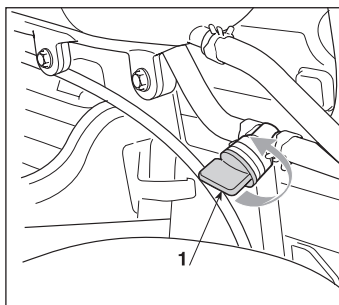

After the machine has run for a few seconds, put the accelerator lever on «START» and then on «SLOW».

IMPORTANT *The choke (if provided) must be closed as soon as the engine is running smoothly. Using it when the engine is already warm can foul the spark plugs and cause the engine to run erratically.*

NOTE *If there are engine starting problems, do not insist as you can risk running the battery flat and flooding the engine. Turn the key to the «OFF» position, wait for a few seconds and then repeat the operation. If the malfunction persists, refer to the engine manual and «Troubleshooting» section in this manual.*

IMPORTANT *Always bear in mind that the safety devices prevent the engine from starting if safety requirements have not been met (see 5.2). In these cases, once the situation has been corrected, the key must first be turned back to «OFF» before the engine can be restarted.*



Moving without mowing

When moving the machine:

- disengage the cutting means;

- bring the cutting-means assembly to the highest position (position «7»);
- put the accelerator control between the «SLOW» and «FAST» positions.



Mechanical transmission

- Push the pedal down as far as possible ( page 22, n. 11) and move the gear change lever into 1st gear ( page 22, n. 12).
- Keep the pedal pressed down and disengage the parking brake ( page 20, n. 2).
- Slowly release the pedal which will turn from «brake» to «clutch», thus operating the rear wheels.

⚠ WARNING! *The pedal has to be released gradually, as a sudden engagement may cause the vehicle to tip over and the driver to lose control.*

- Gradually reach the desired speed using the throttle and gear lever. To change gear, press the clutch halfway down ( page 22, n. 11).

Hydrostatic transmission:

- Disengage the parking brake and release the brake pedal ( page 22, n. 21).
- Press the drive pedal ( page 22, n. 22) in direction «F» and reach the required speed by progressively increasing pressure on the pedal and moving the accelerator.

⚠ WARNING! *Drive must be engaged as described below ( page 22, n. 22) to prevent sudden engagement from causing tipping up and loss of control of the vehicle, particularly on slopes.*

Braking

Mechanical transmission

- To use the brake, press the brake pedal to the floor ( page 22, n. 11), after reducing speed using the accelerator so as not to overload the braking system.

Hydrostatic transmission:

- First reduce the machine's speed by reducing the engine's r.p.m., and then press the brake pedal ( page 22, n. 21) to slow down the machine until it stops.
- The machine already slows down considerably by just releasing the drive pedal.

Reverse

IMPORTANT *Reverse must only be engaged when the machine has stopped.*

IMPORTANT *To proceed in reverse gear with the cutting means engaged, it is necessary to press and hold the consent pedal down (see 4.7) so as not to cause the engine to stop.*

Mechanical transmission



- Press the pedal until the machine stops and then switch into reverse by shifting the lever sideways and into position «R» ( page 22, n. 12). Gradually release the pedal to
- engage the clutch and then begin moving in reverse.

Hydrostatic transmission:

- When the machine is stopped, start the reverse movement by pressing the drive pedal in the «R» direction ( page 22, n. 22).

Grass cutting

To start cutting:

- move the throttle to «FAST»;
- bring the cutting-means assembly to the highest position;
- engage the cutting means ( page 20, n. 3) only on grass lawns; avoid engaging them on stony ground or when the grass is very high;
- start moving forwards on the grass very slowly and with utmost caution, as already described;
- regulate the cutting height ( page 21, n. 4) and speed considering the conditions of the lawn (the height, density and dampness of the grass).

Mechanical transmission

- – High and dense grass – wet lawn: 1st gear
- – Low grass – dry lawn: 2nd 3rd gear

NOTE *The fourth gear is just a transfer gear to be used on the flat.*

Hydrostatic transmission:

- Speed can be adjusted according to lawn conditions by gradually and continuously pressing the speed adjustment pedal accordingly.

⚠ WARNING! *When cutting on sloping ground, the forward speed must be reduced to ensure safe conditions ( Safety regulations C7-8-9).*

Whatever the conditions, always reduce the speed if you notice a drop in engine speed – if you travel too fast compared to the amount of grass being cut, you will not be able to mow the grass well.

Disengage the cutting means and raise the cutting-means assembly as high as possible whenever you need to get past an obstacle.

Emptying the grass catcher

NOTE *The emptying of the grass catcher can only be done with the cutting means disengaged, otherwise the engine stops.*

The grass catcher is full when the grass cuttings remain on the lawn. If you continue mowing with the grass catcher full, it may block the collector channel.

To empty the grass catcher:

- disengage the cutting means (☛ page 20, n. 3);
- lower the engine speed;
- shift into neutral (N) (☛ page 22, n. 12 = Mechanical transmission, or ☛ page 22, n. 12 = Hydrostatic transmission) and stop moving forward;
- engage the parking brake on slopes;
- hold onto the rear handle (1) and tip up the grass catcher to empty it;



Unblocking the collector channel

Cutting very tall or wet grass, particularly at excessively high speed, can clog up the collector channel. If this happens proceed as follows:

- stop forward movement immediately, disengage the cutting means and stop the engine;
- remove the grass catcher;
- remove the grass cuttings; you can reach them from the channel discharge opening.

⚠ WARNING! *This job must only be performed with the engine turned off.*

End of mowing

When you have finished mowing, disengage the cutting means, reduce the engine speed and ride the machine with the cutting-means assembly in the highest position.

End of work

Stop the machine, put the accelerator lever in the «SLOW» position and turn off the engine by putting the ignition key into the «OFF» position.

When the engine has stopped, close the fuel stopcock (1) (if fitted).

⚠ WARNING! *To avoid backfire, put the accelerator in the «SLOW» position for 20 seconds before stopping the engine.*

IMPORTANT *To keep the battery charged, do not leave the ignition key in the «ON» position when the engine is not running.*

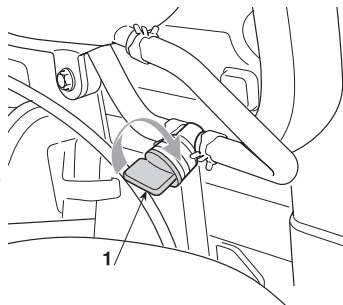

Cleaning the machine

After each mowing session, clean the outside of the machine, empty the grass catcher and shake it to remove residual grass and earth.

Clean the plastic parts of the body with a damp sponge using water and detergent, taking care not to wet the engine, the electrical parts or the electronic circuit board located under the seat.

IMPORTANT *Never use hose-nozzles or harsh detergents for cleaning the body and engine!*

⚠ WARNING! *Do not let debris and dried grass accumulate in the upper part of the cutting-means assembly in order to maintain maximum machine efficiency and safety levels.*

After each use, clean the cutting-means assembly thoroughly to remove any grass remains or debris.

⚠ WARNING! *Wear eye protection and keep people or animals away from the surrounding area when cleaning the cutting-means assembly.*

a) When washing the inside of the cutting-means assembly and the collector channel, the machine must be on firm ground:

- prepare the machine according to the operating mode that was used the last time;
- connect a water hose to its pipe fitting (1), and run water through it;
- sit in the operator's position;
- lower the cutting-means assembly completely;
- start the engine and stay in neutral;
- engage the cutting means and allow them to run idle for a few minutes.

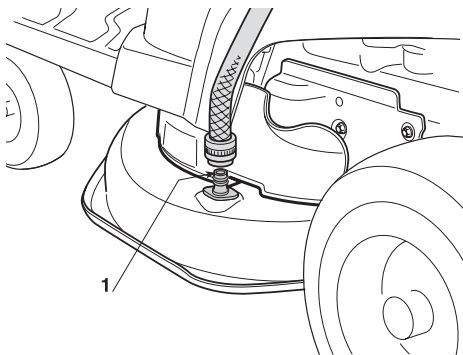

Remove the grass catcher, the side discharge chute or mulching attachment (if provided), rinse and place them where they can dry quickly.

b) To clean the upper part of the cutting-means assembly:

- lower the cutting-means assembly completely (position «1»);
- blow a jet of compressed air through the right and left guard openings.

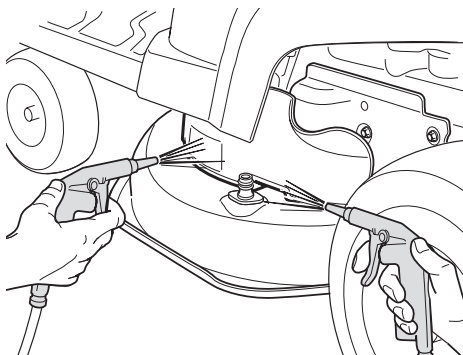

Storage and inactivity for long periods

If you intend not to use the machine for a long period (more than 1 month), disconnect the battery cables and follow the instructions in the engine instruction manual. Close the fuel stopcock (1).

Remove the clamp (2) using pliers, reconnect the tube (3) and empty the tank collecting all the fuel in a suitable container.

Open the tap (1) and start the engine, leaving it running till it stops because all fuel left in the tubes and carburettor has been used up.

Reconnect the tube (3) making sure you position the clamp properly (2).

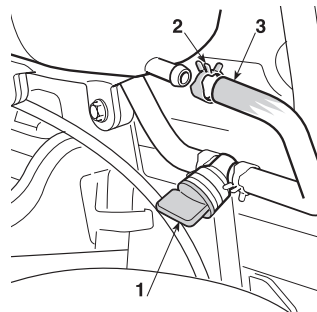

Put the machine away in a dry, sheltered place and preferably covered with a cloth (☛ page 6, n. 3).

IMPORTANT *The battery must be kept in a cool and dry place. Before a long storage period (more than 1 month), always charge the battery, and then recharge before using again.*

The next time the machine is used, check that there are no fuel leaks from the tubes, fuel stopcock or carburettor.

USING ON SLOPES

Observe the indicated limits (max 10° - 17%).

⚠ WARNING! *Take care when beginning forward movement on sloping ground to prevent the risk of tipping up. Reduce the forward speed before going on a slope, particularly downhill.*

⚠ DANGER! *Never switch to reverse gear to decrease speed when going downhill: this could cause loss of control of the machine, especially on slippery ground.*



☞ Mechanical transmission

- **⚠ DANGER!** *Never ride the machine on slopes in neutral or with the clutch out!*
- *Always shift into a low gear before leaving the machine at a standstill and unattended.*

☞ Hydrostatic transmission:

- Drive down slopes with your foot off the drive pedal (☛ page 23, n. 22) to use the braking effect of the hydrostatic transmission when the transmission is not engaged.

SUGGESTIONS FOR MAINTAINING A NICE LAWN

1. To keep a lawn green and soft with a good appearance, it should be cut regularly without damaging the grass. A lawn can be composed of different types of grass. If the lawn is cut frequently, grass and roots grow more vigorously, forming a solid grassy bed. If the lawn is cut less frequently, higher grass and weeds start growing (clover and daisies, etc.).
2. It is always better to cut the grass when dry.
3. The cutting means must be in good condition and well sharpened so that the grass is cut straight without a ragged edge that leads to yellowing at the ends.
4. The engine must run at full speed, both to ensure a sharp cut of the grass and to get the necessary thrust to push the cuttings through the collector channel.
5. The frequency of mowing should be in relation to the rate of growth of the grass, which should not be left to grow too much between one cut and the next.
6. During hot and dry periods, the grass should be cut a little higher to prevent the ground from drying out.
7. The best height of the grass on a well-kept lawn is approx. 4-5 cm. and with one mowing, you do not need to remove more than a third of the total height. If the grass is very tall, it should be cut twice in a twenty-four hour period. The first time with the cutting means at maximum cutting height, possibly reducing the cutting width and the second cut at the height desired.
8. The appearance of the lawn will improve if you alternate the cutting in both directions.
9. If the collector system tends to get blocked with grass, you should reduce the forward speed as it may be too high for the condition of the grass. If the problem persists, the probable causes are either badly sharpened cutting means or deformed fins.
10. Be very careful when mowing near bushes or kerbs as these could distort the horizontal position of the cutting-means assembly and damage its edge as well as the cutting means.

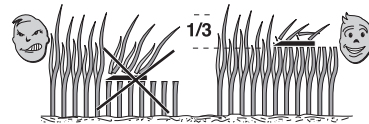
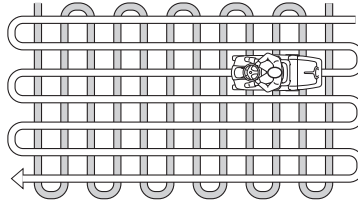

Care and maintenance

SAFETY RECOMMENDATIONS

⚠ WARNING! *You must go to a specialized Service Centre or contact your Dealer if the following are malfunctioning:*

- *the brake;*
- *the cutting means engage and disengage functions,*
- *switching the drive to forward or reverse gears.*

ROUTINE MAINTENANCE

The table will help you maintain your machine's safety and performance. It summarises the main interventions to be made and the frequency applicable to each of them.

The boxes at the side are for you to mark the date or number of working hours at which the intervention was made.

Operation	Hours	Completed (Date or Time)
1. MACHINE		
1.1 Cutting means positioning and sharpening check ³⁾	25	
1.2 Replacing cutting means ³⁾	100	
1.3 Transmission belt check ³⁾	25	
1.4 Transmission belt replacement ²⁾³⁾	–	
1.5 Cutting means control belt check ³⁾	25	
1.6 Replacing the cutting means control belt check ²⁾³⁾	–	
1.7 Brake regulation and check ³⁾	25	
1.8 Drive regulation and check ³⁾	25	
1.9 Cutting means engage and brake check ³⁾	25	
1.10 Cutting means engage and brake check	25	
1.11 General lubrication ⁴⁾	25	
2. ENGINE ¹⁾		
2.1 Replacement of the engine oil	
2.2 Air filter cleaning and check	
2.3 Air filter replacement	
2.4 Fuel filter check	
2.5 Fuel filter replacement	
2.6 Spark plug points cleaning and check	
2.7 Replacement of spark plug	

¹⁾ See the engine manual for the full list and frequency.

²⁾ At the first signs of any malfunction, contact your Dealer immediately.

³⁾ The operation must be carried out by your Dealer or a specialized Service Centre.

⁴⁾ General lubrication of all joints should also be carried out whenever the machine is to be left unused for a long period.

Engine

Follow all the instructions in the engine manual. The engine oil is emptied using a syringe (2) (attachment on request) suited for that use, after unscrewing the cap (1).

Fit a small pipe (3) of the right size and at least 400mm long on to the syringe (2) ; push the small pipe (3) into the hole completely, then suck all the oil out; please remember that this operation has to be repeated a few times to empty it completely.

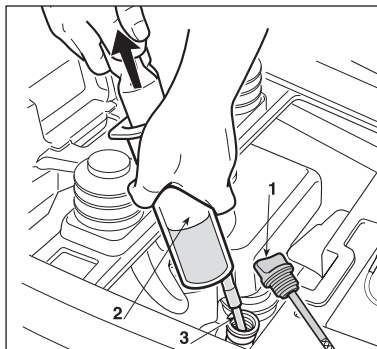

Rear axle

This is a sealed single unit that does not require maintenance. It is permanently lubricated and its lubricant does not need changing or topping up.

Battery

To ensure long life to the battery it is essential to keep it carefully maintained.

The machine battery must always be charged:

- before using the machine for the first time after purchase;
- before leaving the machine disused for a long period;
- before starting up the machine after a prolonged period of inactivity.

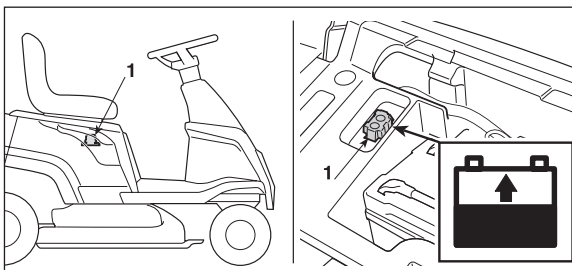

Carefully read and observe the battery recharging instructions in the booklet provided with the battery. Failure in following the procedure or in charging the battery could permanently damage the battery elements. A flat battery must be recharged as soon as possible.

IMPORTANT *Recharging must be done using a battery charger at constant voltage. Other recharging systems can irreversibly damage the battery.*

The machine comes with a connector (1) for recharging; this is connected to the corresponding connector for the special maintenance battery-charger supplied (if included) or available on request (☛ page 6, n. 4).

IMPORTANT *This connector must only be used for connection to the maintenance battery-charger indicated by the Manufacturer. For its use:*

- follow the instructions given in the relative instructions manual;
- follow the instructions in the battery manual.

INTERVENTIONS ON THE MACHINE

Aligning the cutting-means assembly

The cutting-means assembly should be properly adjusted to obtain an evenly mown lawn.

If mowing is uneven, check the tyre pressure.

If this is not sufficient to achieve an even cut, please contact your Dealer to adjust the alignment of the cutting-means assembly.

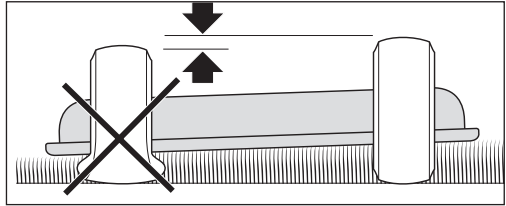

Replacing the wheels

Stop the machine on flat ground and put a block under a load-bearing part of the frame on the side that the wheel is to be changed.

The wheels are held by a snap ring (1) which can be removed with a screwdriver.

NOTE If you have to replace one or both rear wheels, make sure that any differences in their external diameter does not exceed 8-10 mm; on the contrary, you must adjust the cutting-means assembly alignment to prevent uneven mowing.

IMPORTANT Before remounting the wheel, apply grease to the axle. Put the snap ring (1) and shoulder washer (2) back in place.

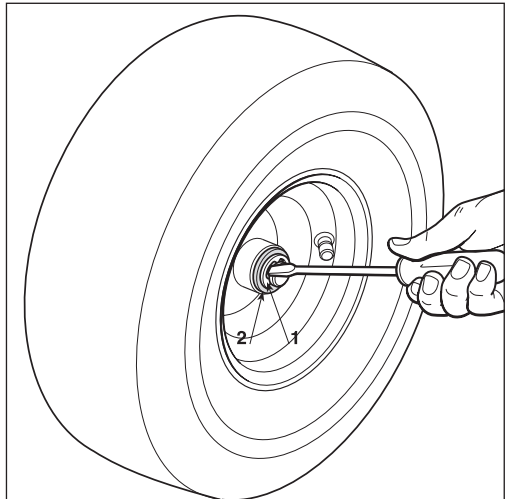

Repairing or replacing tyres

All puncture repairs or replacements will have to be carried out by a tyre repair expert in accordance with the methods for the kind of tyre used.

Replacing a fuse

The electric system and the electronic circuit board are protected by a fuse. When it blows the machine stops. In this case, remove the cover (1) to reach the fuse (2) next to the battery. The fuse capacity is indicated on the fuse.

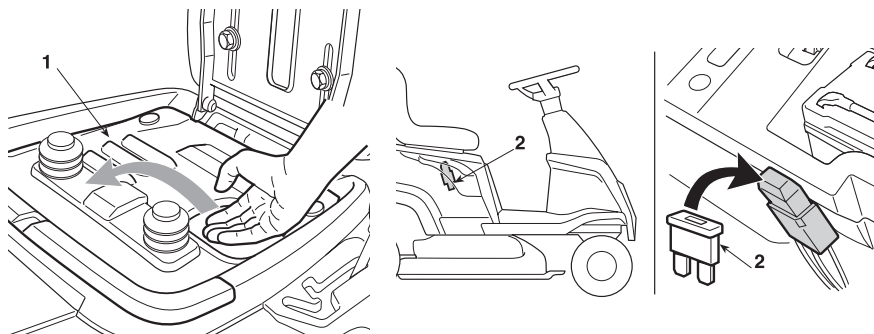

IMPORTANT A blown fuse must always be replaced by one of the same type and ampere rating, and never with one of another rating.

If you cannot find out why the fuse has blown, consult a Licensed Service Centre.

Removing, replacing and reassembling of cutting means

⚠ WARNING! Always wear strong protective gloves to handle the cutting means.

⚠ WARNING! Always replace damaged or bent cutting means; never attempt to repair them! ALWAYS USE ORIGINAL CUTTING MEANS!

Only cutting means bearing the code indicated in the table on page 5 must be used on this machine.

Given product evolution, the above mentioned cutting means may be replaced in time with others having similar interchangeable and operating safety features.

Troubleshooting

PROBLEM	LIKELY CAUSE	SOLUTIONS
1. With the key on «START» the starter motor does not run.	<p>Electronic circuit board blocked due to:</p> <ul style="list-style-type: none"> – flat battery – fuse blown – bad earthing to the engine or the frame – earth connections of the microswitches disconnected – badly earthed starter motor – starting conditions have not been met 	<p>Turn the ignition key to «STOP» position and look for the cause of the problem:</p> <ul style="list-style-type: none"> – recharge the battery (🔌 page 35) – replace the fuse (10 A) (🔌 page 36) – check connections of black earth leads – check connections – check earth connections – check that the conditions allowing the start are met (🔌 page 24)
2. With the key on «START» the starter motor runs but the engine does not start	<ul style="list-style-type: none"> – faulty fuel supply – faulty ignition 	<ul style="list-style-type: none"> – check the level in the tank (🔌 page 25) – check the fuel filter – check that spark plug cap is securely fitted – check that the electrodes are clean and have the correct gap
3. The engine stops	<p>Electronic circuit board blocked due to:</p> <ul style="list-style-type: none"> – earth connections of the microswitches disconnected – flat battery – badly connected battery (poor contact) – engine badly earthed 	<p>Turn the ignition key to «STOP» position and look for the cause of the problem:</p> <ul style="list-style-type: none"> – check connections – recharge the battery (🔌 page 35) – check connections (🔌 page 17) – check engine earth connection
4. Starting is difficult or the engine runs erratically	<ul style="list-style-type: none"> – fault in carburetion 	<ul style="list-style-type: none"> – clean or replace the air filter – flush out the float chamber – empty the fuel tank and refill with fresh fuel – check and replace the fuel filter if necessary
5. Weak engine performance during cutting	<ul style="list-style-type: none"> – forward speed too high in relation to cutting height 	<ul style="list-style-type: none"> – reduce the forward speed and/or raise the cutting height (see 4.4)
6. The engine switches off when the cutting device is engaged	<ul style="list-style-type: none"> – the movement of the lever used to engage the cutting means is too brusque – you are not ready to engage the cutting means 	<ul style="list-style-type: none"> – do it more slowly – check that the safety requirements are met (🔌 page 24)

PROBLEM	LIKELY CAUSE	SOLUTIONS
7. Uneven mowing and poor grass collection	<ul style="list-style-type: none"> – cutting-means assembly is not parallel to the ground – inefficient cutting means; – forward speed too high compared to height of grass – collector channel is blocked – cutting-means assembly is full of grass 	<ul style="list-style-type: none"> – check the tyre pressure (🔧 page 25) – reinstate the alignment of the cutting-means assembly in relation to the ground (🔧 page 36) – contact your dealer – reduce the forward speed and/or raise the cutting-means assembly (🔧 page 29) – wait for the grass to dry – remove the grass catcher and empty the collector channel (🔧 page 30) – clean the cutting-means assembly (🔧 page 31)
8. Unusual vibrations while working	<ul style="list-style-type: none"> – the cutting means are unbalanced – the cutting means are loose – loose bolts and screws 	<ul style="list-style-type: none"> – contact your dealer – contact your dealer – check and tighten all the engine and frame bolts
9. The cutting means do not engage or do not stop promptly when they are disengaged	<ul style="list-style-type: none"> – problems with engagement mechanism 	<ul style="list-style-type: none"> – contact your dealer
10. Uncertain or ineffective braking	<ul style="list-style-type: none"> – the brake is not adjusted correctly 	<ul style="list-style-type: none"> – contact your dealer
11. Erratic forward movement, poor drive when going uphill or if the machine has a tendency to rear up	<ul style="list-style-type: none"> – problems with the belt or the engagement device 	<ul style="list-style-type: none"> – contact your dealer
12. With the engine running, the machine does not move when the drive pedal is pressed (hydrostatic transmission)	<ul style="list-style-type: none"> – release lever in position «B» 	<ul style="list-style-type: none"> – put into position «A» (🔧 page 23, n 23).

If problems persist after having performed the above operations, contact your dealer.

⚠ WARNING! *Do not take on complicated repair work without the necessary equipment and technical knowledge. The guarantee is automatically revoked and the manufacturer declines all responsibility for any poorly effected repairs.*

Service Link



This product is supported by Service Link. If you have been unable to find the information you require above please call the Service Link helpline. Here you will find 1-2-1 help and advice from garden machinery repair specialists.



DICHIAZIONE CE DI CONFORMITÀ (Istruzioni Originali)

(Diretiva Macchine 2006/42/CE, Allegato II, Parte A)

1. La Società: ST. S.p.A. - Via del Lavoro, 6 - 31033 Castelfranco Veneto (TV) - Italy

Dichiaro sotto la propria responsabilità, che i macchinari, Toarsaeta con conduttore a bordo seduto / taglio erb...

- a) Tipo / Modello Base
b) Messa/Anno di costruzione
c) Matrícula

d) Motore a scoppio

3. È conforme alle specifiche della direttiva:

- MD: 2006/42/CE
a) Direttiva Certificazione:
b) Esame CE del tipo:

CND: 2000/14/EC, ANNEX VI, 2005/88/EC
D. Lgs. 2002/2002, ANNEX VI, proc. (Italy)
a) Direttiva Certificazione:
b) Esame CE del tipo:

EMCD: 2014/30/EU

4. Riferimento alla Norme armonizzate:

EN ISO 5985-1:2013 EN ISO 5107:2007(A):2009
EN ISO 5985-3:2013(A):2017 EN ISO 14882:2009

g) Livello di potenza sonora misurato 98 dB(A)
h) Livello di potenza sonora garantito 98 dB(A)
i) Ampiezza di taglio: 66 cm

Personale autorizzato a costruire il Fascicolo Tecnico:

ST. S.p.A.
Via del Lavoro, 6
31033 Castelfranco Veneto (TV) - Italia

Castelfranco V.to, 20/12/2017

Senior VP R&D & Engineering
Mauro Turisini

171912682_7

Rev. 0001/17

Table with 6 columns and 6 rows containing technical specifications and conformity declarations in multiple languages (English, Italian, German, French, Spanish, Dutch).

In more detail...

Model:

Year S/N°

CE

The form is enclosed in a rounded rectangle. At the top left, there is a cross-hatched rectangular area. Below it, a hand is shown writing on a horizontal line. To the right of the hand is a speaker icon. Below the speaker icon is the text 'LWA'. Below 'LWA' is another cross-hatched rectangular area. To the right of this area is the text 'dB'. Below the 'Model:', 'Year', and 'S/N°', there is a horizontal line. To the right of this line is the CE mark.

As soon as you have purchased the machine, write the machine identification data (3 - 5 - 6) found on the identification label in the spaces provided (IDENTIFICATION OF THE MACHINE).

ST. S.p.A.

Via del Lavoro, 6

31033 Castelfranco Veneto (TV) ITALY

171505972/2