

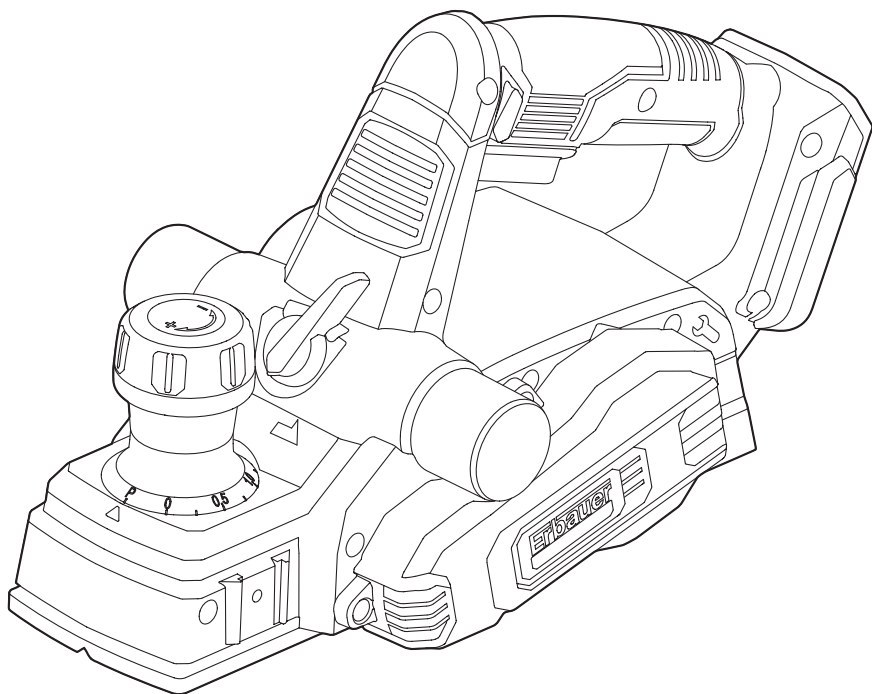

**Erbauer**



MNL\_EHP18-Li\_V01\_180608

EAN. 3663602799689

# EHP18-Li

ORIGINAL INSTRUCTIONS

EN



Safety instructions



Product description



Assembly



Use



+



Care & maintenance



Guarantee



Declaration of Conformity



**WARNING!** Please read all safety warnings carefully and be sure that they are fully understood before handling the tool.

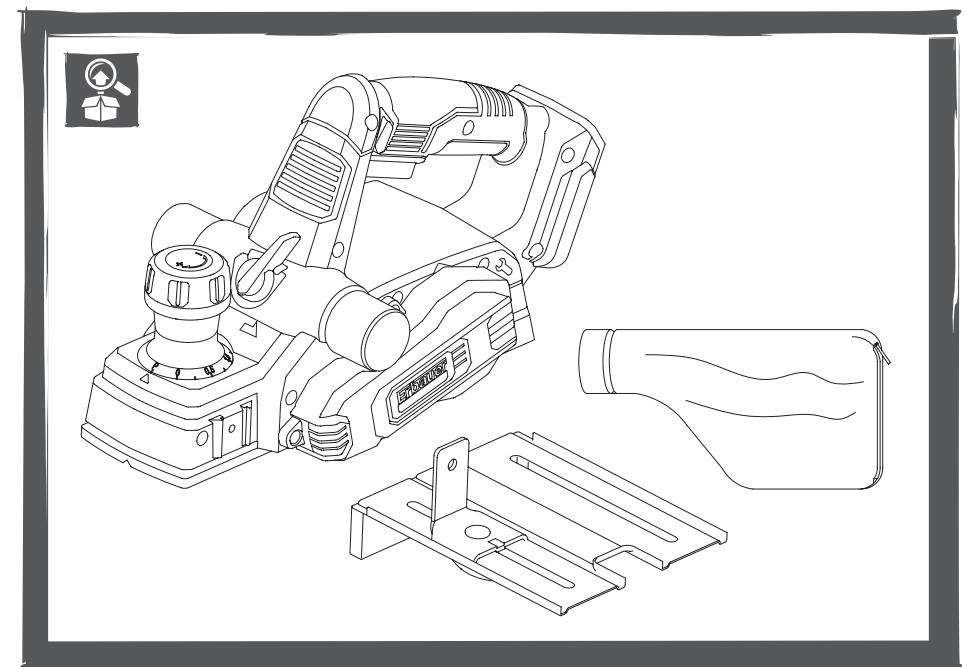

# PRODUCT DESCRIPTION



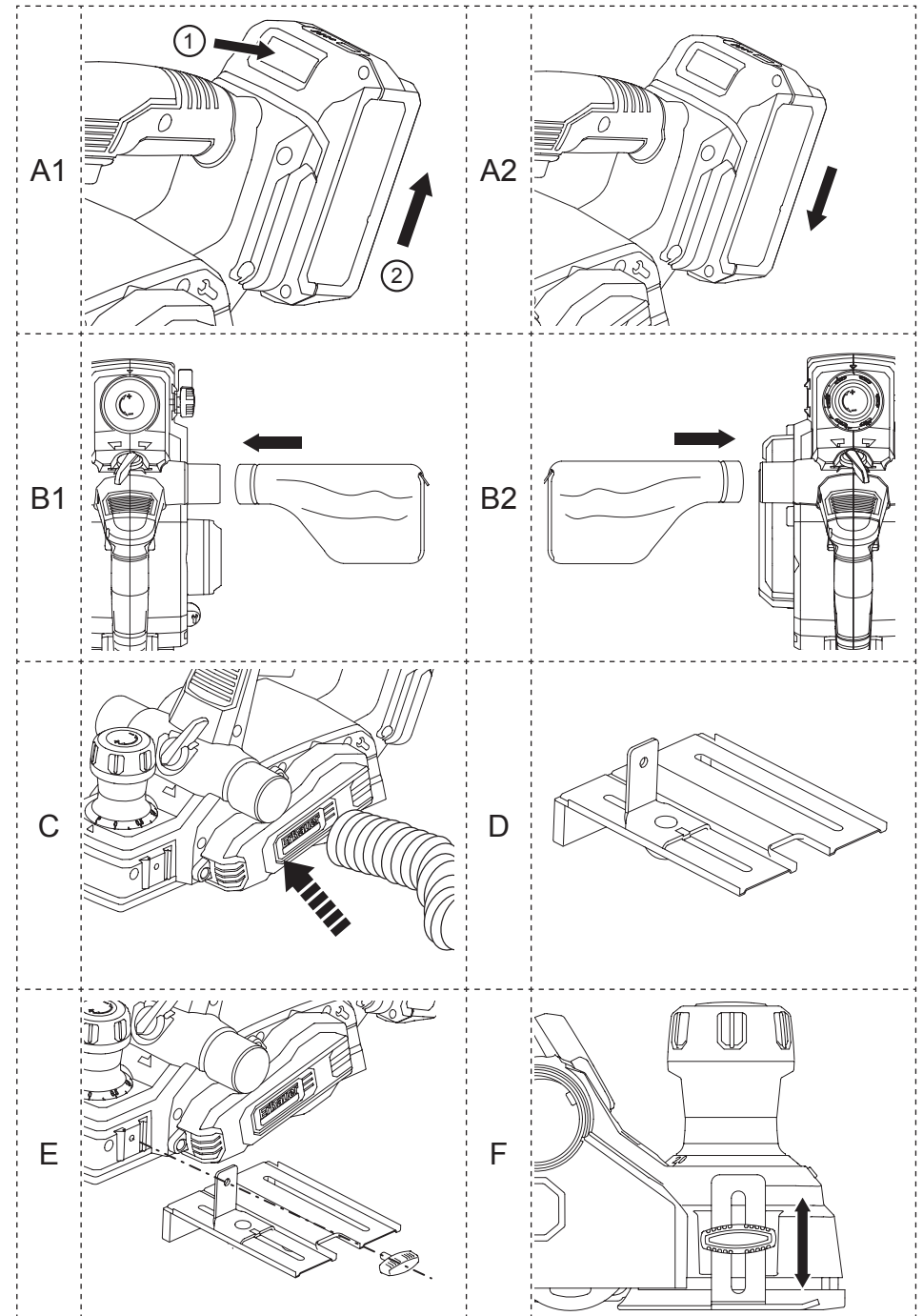
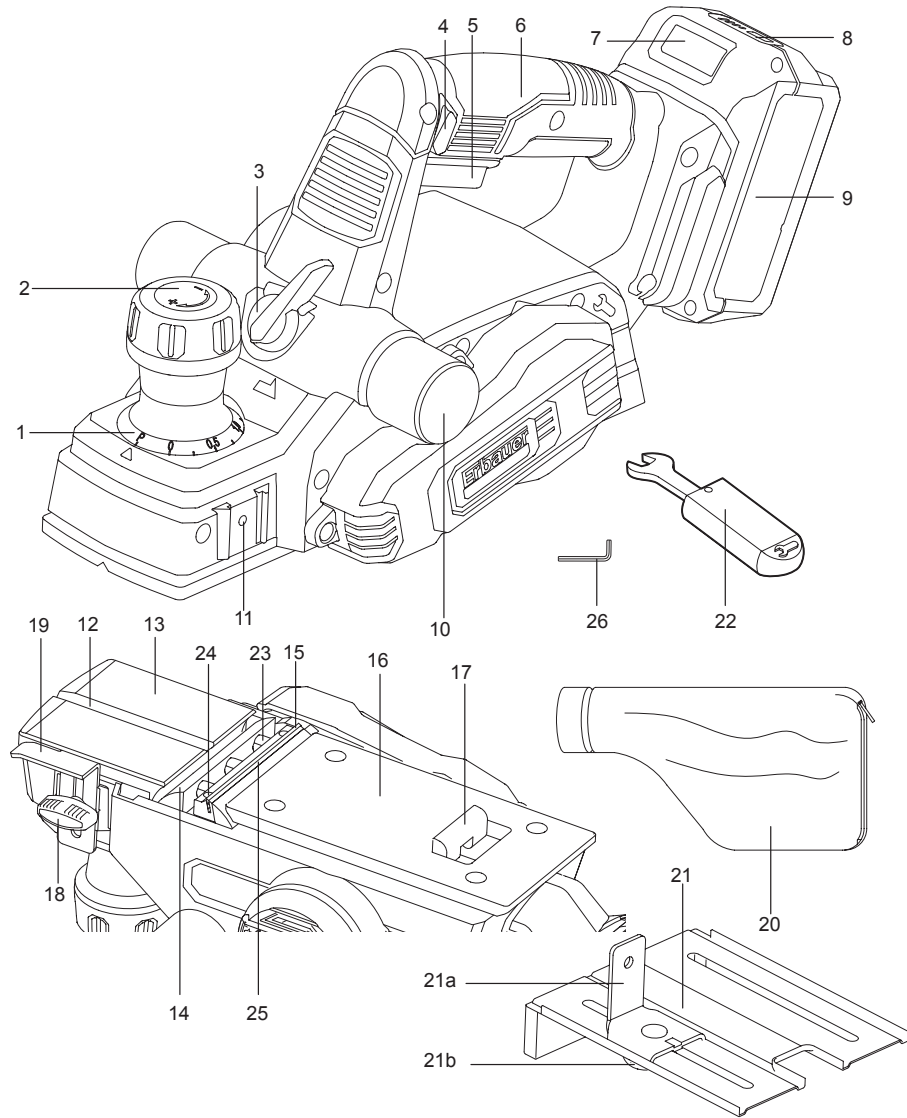

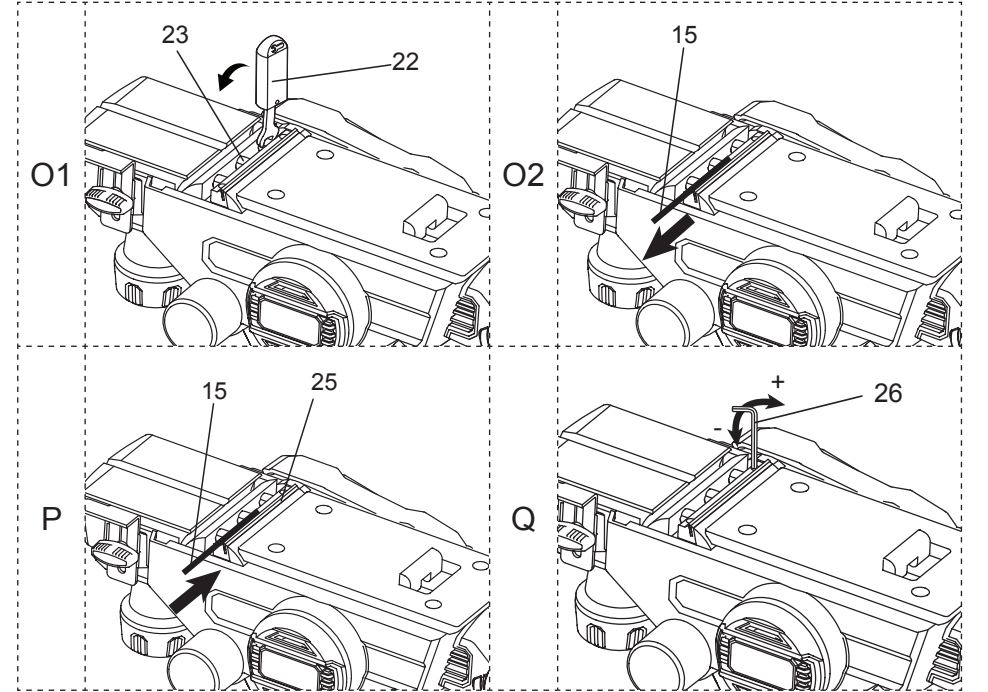
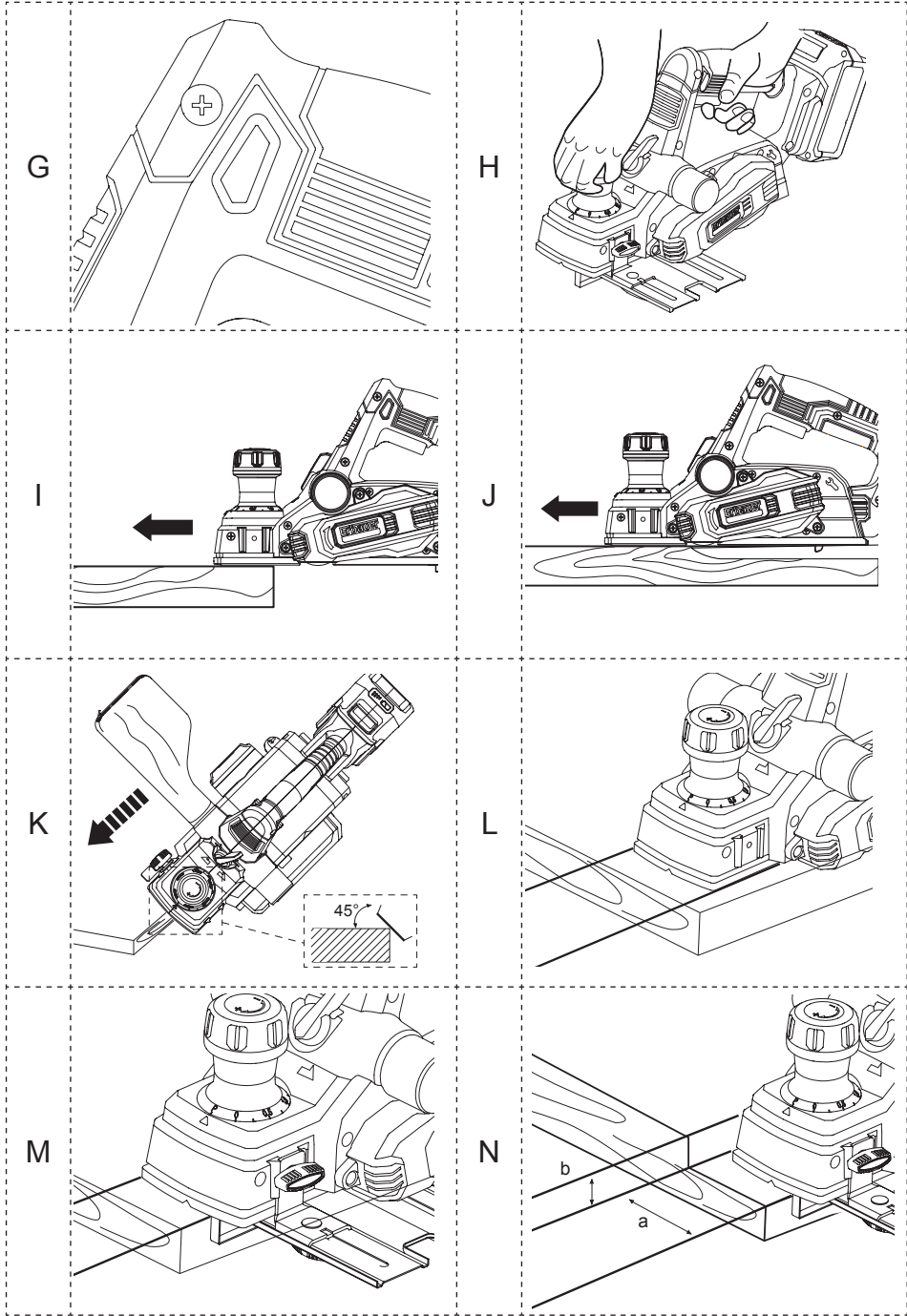

## SAFETY INSTRUCTIONS

### GENERAL POWER TOOL SAFETY WARNINGS



**WARNING!** Read all safety warnings, instructions, illustrations and specifications provided with this power tool. Failure to follow all instructions listed below may result in electric shock, fire and/or serious injury.

Save all warnings and instructions for future reference. The term “power tool” in the warnings refers to your mains-operated (corded) power tool or battery operated (cordless) power tool.”

#### WORK AREA SAFETY

- a. **Keep work area clean and well lit.** Cluttered or dark areas invite accidents.
- b. **Do not operate power tools in explosive atmospheres, such as in the presence of flammable liquids, gases or dust.** Power tools create sparks which may ignite the dust or fumes.
- c. **Keep children and bystanders away while operating a power tool.** Distractions can cause you to lose control.

#### ELECTRICAL SAFETY

- a. **Power tool plugs must match the outlet. Never modify the plug in any way. Do not use any adapter plugs with earthed (grounded) power tools.** Unmodified plugs and matching outlets will reduce risk of electric shock.
- b. **Avoid body contact with earthed or grounded surfaces, such as pipes, radiators, ranges and refrigerators.** There is an increased risk of electric shock if your body is earthed or grounded.

- c. **Do not expose power tools to rain or wet conditions.** Water entering a power tool will increase the risk of electric shock.
- d. **Do not abuse the cord. Never use the cord for carrying, pulling or unplugging the power tool. Keep cord away from heat, oil, sharp edges or moving parts.** Damaged or entangled cords increase the risk of electric shock.
- e. **When operating a power tool outdoors, use an extension cord suitable for outdoor use.** Use of a cord suitable for outdoor use reduces the risk of electric shock.
- f. **If operating a power tool in a damp location is unavoidable, use a residual current device (RCD) protected supply.** Use of an RCD reduces the risk of electric shock.

#### PERSONAL SAFETY

- a. **Stay alert, watch what you are doing and use common sense when operating a power tool. Do not use a power tool while you are tired or under the influence of drugs, alcohol or medication.** A moment of inattention while operating power tools may result in serious personal injury.
- b. **Use personal protective equipment. Always wear eye protection.** Protective equipment such as a dust mask, non-skid safety shoes, hard hat, or hearing protection used for appropriate conditions will reduce personal injuries.
- c. **Prevent unintentional starting. Ensure the switch is in the off- position before connecting to power source and/or remove battery pack, picking up or carrying the tool.** Carrying power tools with your finger on the switch or energising power tools that have the switch on invites accidents.
- d. **Remove any adjusting key or wrench before turning the power tool on.** A wrench or a key left attached to a rotating part of the power tool may result in personal injury.
- e. **Do not overreach. Keep proper footing and balance at all times.** This enables better control of the power tool in unexpected situations.



- f. **Dress properly. Do not wear loose clothing or jewellery. Keep your hair, clothing away from moving parts.** *Loose clothes, jewellery or longhair can be caught in moving parts.*
- g. **If devices are provided for the connection of dust extraction and collection facilities, ensure these are connected and properly used.** *Use of dust collection can reduce dust-related hazards.*
- h. **Do not let familiarity gained from frequent use of tools allow you to become complacent and ignore tool safety principles.** *A careless action can cause severe injury within a fraction of a second.*

#### POWER TOOL USE AND CARE

- a. **Do not force the power tool. Use the correct power tool for your application.** *The correct power tool will do the job better and safer at the rate for which it was designed.*
- b. **Do not use the power tool if the switch does not turn it on and off.** *Any power tool that cannot be controlled with the switch is dangerous and must be repaired.*
- c. **Disconnect the plug from the power source and/or remove the battery pack, if detachable, from the power tool before making any adjustments, changing accessories, or storing power tools.** *Such preventive safety measures reduce the risk of starting the power tool accidentally.*
- d. **Store idle power tools out of the reach of children and do not allow persons unfamiliar with the power tool or these instructions to operate the power tool.** *Power tools are dangerous in the hands of untrained users.*
- e. **Maintain power tools and accessories. Check for misalignment or binding of moving parts, breakage of parts and any other condition that may affect the power tools operation. If damaged, have the power tool repaired before use.** *Many accidents are caused by poorly maintained power tools.*

- f. **Keep cutting tools sharp and clean.** *Properly maintained cutting tools with sharp cutting edges are less likely to bind and are easier to control*
- g. **Use the power tool, accessories and tool bits etc. in accordance with these instructions, taking into account the working conditions and the work to be performed.** *Use of the power tool for operations different from those intended could result in a hazardous situation.*
- h. **Keep handles and grasping surfaces dry, clean and free from oil and grease.** *Slippery handles and grasping surfaces do not allow for safe handling and control of the tool in unexpected situations.*

#### BATTERY TOOL USE AND CARE

- a. **Recharge only with the charger specified by the manufacturer.** *A charger that is suitable for one type of battery pack may create a risk of fire when used with another battery pack.*
- b. **Use power tools only with specifically designated battery packs.** *Use of any other battery packs may create a risk of injury and fire.*
- c. **When battery pack is not in use, keep it away from other metal objects, like paper clips, coins, keys, nails, screws or other small metal objects, that can make a connection from one terminal to another.** *Shorting the battery terminals together may cause burns or a fire.*
- d. **Under abusive conditions, liquid may be ejected from the battery; avoid contact. If contact accidentally occurs, flush with water. If liquid contacts eyes, additionally seek medical help.** *Liquid ejected from the battery may cause irritation or burns.*
- e. **Do not use battery pack or tool that is damaged or modified.** *Damaged or modified batteries may exhibit unpredictable behaviour resulting in fire, explosion or risk of injury.*

- f. **Do not expose a battery pack or tool to fire or excessive temperature.** *Exposure to fire or temperature above 130 °C may cause explosion.*
- g. **Follow all charging instructions and do not charge the battery pack or tool outside the temperature range specified in the instructions.** *Charging improperly or at temperatures outside the specified range may damage the battery and increase the risk of fire.*

### SERVICE

- a. **Have your power tool serviced by a qualified repair person using only identical replacement parts.** *This will ensure that the safety of the power tool is maintained.*
- b. **Never service damaged battery packs.** *Service of battery packs should only be performed by the manufacturer or authorized service providers.*

### PLANER SAFETY WARNINGS

- a. **Wait for the cutter to stop before setting the tool down.** *An exposed rotating cutter may engage the surface leading to possible loss of control and serious injury.*
- b. **Use clamps or another practical way to secure and support the workpiece to a stable platform.** *Holding the work by your hand or against the body leaves it unstable and may lead to loss of control.*
- c. *Be aware of kickback.*
- d. *Turn the product off immediately, if the cutting blade gets jammed.*
- e. *Never slow down the application tool yourself mechanically. Always allow the product to come to complete stop on its own.*
- f. *Never touch the workpiece with your hand when you are working on it.*
- g. *Do not work overhead.*
- h. *Ensure that the workpiece is free of foreign objects such as screws or nails.*

### ADDITIONAL SAFETY WARNINGS FOR BATTERY

- a. *Do not connect the positive terminal and negative terminal of the battery to each other with any metal object (such as wire).*
- b. *Do not carry or store battery together with necklaces, hairpins or other metal objects.*
- c. *Do not pierce the battery with nails, strike the battery with a hammer, step on the battery or otherwise subject it to strong impacts or shocks.*
- d. *Do not solder directly onto the battery.*
- e. *Do not expose battery to water or salt water, or allow the battery to get wet.*
- f. *Do not disassemble or modify the battery.*
- g. *Do not place the battery in or near fire, on stoves or other high temperature locations. Do not place the battery in direct sunlight, or use or store the battery inside cars in hot weather.*
- h. *Do not place the battery in microwave ovens, high-pressure containers or on induction cookware.*
- i. *If you intend to store a battery for a period without use then store battery at room temperature (19°C to 25°C), charged to about 30 – 50% of capacity. When storing for very long periods boost charge the battery once per year to prevent over discharge.*

The following information applies to professional users only but is good practice for all users:

### **ADDITIONAL SAFETY WARNING FOR CONSTRUCTION DUST**

The updated Control of Substances Hazardous to Health Regulations 1st October 2012 now also targets to reduce the risks associated with silica, wood and gypsumdusts. Construction workers are one of the at-risk groups within this because of the dust that they breathe: silica dust is not just a nuisance; it is a real risk to your lungs!

Silica is a natural mineral present in large amounts in things like sand, sandstone and granite. It is also commonly found in many construction materials such as concrete and mortar. The silica is broken into very fine dust (also known as Respirable Crystalline Silica or RCS) during many common tasks such as cutting, drilling and grinding. Breathing in very fine particles of crystalline silica can lead to the development of: Lung cancer Silicosis Chronic Obstructive Pulmonary Disorder/Chronic obstructive pulmonary disease (COPD) And breathing in fine particles of wood dust can lead to the development of Asthma. The risk of lung disease is linked to people who regularly breathe construction dust over a period of time, not on the odd occasion.

To protect the lung, the COSHH Regulations sets a limit on the amount of these dusts that you can breathe (called a Workplace Exposure Limit or WEL) when averaged over a normal working day. These limits are not a large amount of dust: when compared to a penny it is tiny – like a small pinch of salt: This limit is the legal maximum; the most you can breathe after the right controls have been used.

### **HOW TO REDUCE THE AMOUNT OF DUST?**

1. Reduce the amount of cutting by using the best sizes of building products. Use a less powerful tool e.g. a block cutter instead of angle grinder.

2. Using a different method of work altogether – e.g. using a nail gun to direct fasten cable trays instead of drilling holes first.
3. Please always work with approved safety equipment, such as those dust masks that specially designed to filter out microscopic particles and use the dust extraction facility at all time.

For more information please see the HSE website: <http://www.hse.gov.uk/construction> or <http://www.hse.gov.uk/pubns/cis69.pdf>



**WARNING!** Some dust particles created by power sanding, sawing, grinding, drill and other construction jobs contain chemicals known to cause cancer, birth defects or other reproductive harm. Some examples of these chemicals are:

- Lead from lead-based paints.
- Crystalline silica from bricks and cement and other masonry products.
- Arsenic and chromium from chemically treated timber.
- Your risk from these exposures varies, depending upon how often you do this type of work. To reduce your exposure to these chemicals:
- Work in a well-ventilated area.
- Work with approved safety equipment, such as those dust masks that are specially designed to filter microscopic particles

### **VIBRATION**

The European Physical Agents (Vibration) Directive has been brought in to help reduce hand arm vibration syndrome injuries to power tool users. The directive requires power tool manufacturers and suppliers to provide indicative vibration test results to enable users to make informed decisions as to the period of time a power tool can be used safely on a daily basis and the choice of tool.



## SEE TECHNICAL SPECIFICATIONS IN THE INSTRUCTION MANUAL FOR THE VIBRATION LEVELS OF YOUR TOOL.

The declared vibration emission value should be used as a minimum level and should be used with the current guidance on vibration.

Calculating the actual period of use can be difficult and the HSE website has further information.

While working with this power tool, hand/arm vibrations occur. Adopt the correct working practices in order to reduce the exposure to vibration. This tool may cause hand-arm vibration syndrome if its use is not adequately managed.

Helping to minimise your vibration exposure risk. ALWAYS use sharp chisels, drills and blades. Maintain this tool in accordance with these instructions and keep well lubricated (where appropriate).

Avoid using tools in temperatures of 10°C or less. Plan your work schedule to spread any high vibration tool use across a number of days.



**NOTE:** The use of other tools will reduce the users' total working period on this tool.

## HEALTH SURVEILLANCE

All employees should be part of an employer's health surveillance scheme to help identify any vibration related diseases at an early stage, prevent disease progression and help employees stay in work.

## RESIDUAL RISKS

**Even if you are operating this product in accordance with all the safety requirements, potential risks of injury and damage remain. The following dangers can arise in connection with the structure and design of this product:**

1. Injuries and damage to property due to broken attachments or the sudden impact of hidden objects during use.
2. Danger of injury and property damage caused by flying objects or poor power tool accessories.



## PRODUCT DESCRIPTION

- |                                       |                           |
|---------------------------------------|---------------------------|
| 1. Cutting depth scale                | 14. Roller                |
| 2. Cutting depth adjustment knob      | 15. Blade                 |
| 3. Dust/Chip extraction guide switch  | 16. Back plate            |
| 4. Lock-off button                    | 17. Blade protection foot |
| 5. On/off switch                      | 18. Wing screw (x2)       |
| 6. Handle                             | 19. Rebate depth gauge    |
| 7. Battery pack release button        | 20. Dust bag              |
| 8. Power bar button                   | 21. Parallel guide        |
| 9. Battery pack (not included)        | 22. Wrench                |
| 10. Dust extraction outlets (x2)      | 23. Hex screws            |
| 11. Mounting thread (parallel guide ) | 24. Grub screws           |
| 12. V-groove                          | 25. Cutter block          |
| 13. Front plate                       | 26. Hex key               |

## 01 TECHNICAL SPECIFICATIONS

### Planer

|                          |           |
|--------------------------|-----------|
| Rated voltage:           | 18V d.c.  |
| Rated no load speed:     | 14000/min |
| Planing width:           | 82 mm     |
| Cutting depth:           | 0-2mm     |
| Rebating depth:          | 0-8mm     |
| Weight(without battery): | 2.3 kg    |

### For use with battery pack and charger as below:

|   |   |
|---|---|
| Battery pack model:                                 | EBAT18-Li-2 / EBAT18-Li-4 / EBAT18-Li-5 |
| Charger model:                                      | EC18-Li / EFC18-Li / EMC18-Li           |
| Ambient temperature range for tool and battery use: | -10°C to 40°C                           |

### NOISE DATA

|                            |   |
|----------------------------|---|
| A weighted sound pressure: | $L_{pA}=82.5\text{dB(A)}$                   |
| A weighted sound power:    | $L_{wA}=93.5\text{dB(A)}$                   |
| Uncertainty:               | $K_{pA} \text{ \& } K_{wA}=3.0\text{dB(A)}$ |

The noise for the operator may exceed 80 dB(A) and ear protection measures are necessary.

**VIBRATION DATA**

|                    |                       |
|--------------------|-----------------------|
| Hand arm vibration | $a_h=1.2\text{m/s}^2$ |
| Uncertainty        | $K=1.5\text{m/s}^2$   |

The declared vibration total values and the declared noise emission values have been measured in accordance with a standard test method(EN62841-1/EN62841-2-14) and may be used for comparing one tool with another; they may also be used in a preliminary assessment of exposure.



**WARNING !** The vibration and noise emissions during actual use of the power tool can differ from the declared values depending on the ways in which the tool is used especially what kind of workpiece is processed; and need to identify safety measures to protect the operator that are based on an estimation of exposure in the actual conditions of use (taking account of all parts of the operating cycle such as the times when the tool is switched off and when it is running idle in addition to the trigger time).

**RATING LABEL EXPLANATION****EHP18-Li = MODEL NUMBER**

**E** = ERBAUER  
**HP** = HAND PLANER  
**18** = 18V d.c.  
**Li** = LITHIUM ION

**ASSEMBLY****01 SYMBOLS**

Read the instruction manual



Wear eye protection



Wear hearing protection.



Wear a dust mask.



Do not dispose of battery packs in rivers or immerse in water.



Do not dispose of battery packs in fire. They will explode and cause injury.



Do not expose battery packs to heat in excess of 40°C



Brushless motor



Keep Cool Battery Technology

yyWxx

Manufacturing date code: Year of manufacturing (20yy) and week of manufacturing (Wxx)

## 02 UNPACKING

Unpack all parts and lay them on a flat, stable surface.

- Remove all packing materials and shipping devices, if applicable.
- Make sure the delivery contents are complete and free of any damage. If you find that parts are missing or show damage do not use the product but contact your dealer. Using an incomplete or damaged product represents a hazard to people and property.
- Ensure that you have all the accessories and tools needed for assembly and operation. This also includes suitable personal protective equipment



**WARNING!** The product and the packaging are not children's toys! Children must not play with plastic bags, sheets and small parts! There is a danger of choking and suffocation!

## 03 ASSEMBLING THE MACHINE

### CHARGING YOUR BATTERY PACK







The battery has been shipped in a low charge condition. Charge it fully before first use. Refer to the charger instruction manual for the details.

### TO REMOVE OR INSTALL THE BATTERY PACK (A1, A2)

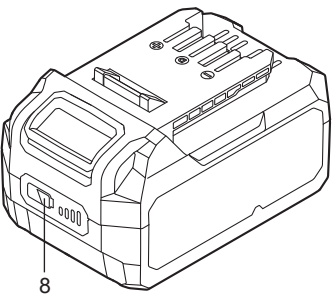
Depress the battery pack release button to release and slide the battery pack out from your tool. After recharge, slide it back into your tool. A simple push and slight pressure will be sufficient.

### BATTERY PACK POWER BAR

The Li-Ion battery pack (9) is equipped with a POWER BAR which is used to give an indication of the battery pack's remaining charge. Press the POWER BAR button (8) to check battery charge as below. The LED will stay lit for approximately 5 seconds.

|   |                 |  |     |
|---|-----------------|--|-----|
|  | 76-100% Charge  |  |     |
|   | 51-75% Charge   |  |     |
|   | 26-50% Charge   |  |     |
|   | 5-25% Charge    |  |     |
|   | under 5% Charge |  |     |
|   | Flash           | On   | Off |

## DUST EXTRACTION (B1, B2, C)



**WARNING!** Attach the dust bag or a dust extraction device when using this product in order to keep the working area clean! Wear a dust mask when operating this product! Dust can be harmful to health! Especially dust of wood that has been treated, e.g. with a wood preservative or stain!

### Selecting left / right dust extraction outlets

To select the dust extraction outlet (10) on the right hand side of the product move the dust / chip extraction guide switch (3) to the left and attach the dust bag (20) or vacuum cleaner to the dust extraction outlet on the right hand side of the machine. To select the dust extraction outlet (10) on the left hand side of the product, do the opposite.

### Dust bag

Carefully align the connector of the dust bag (20) to the dust extraction outlet (10) and insert it all the way to the stop, turn the connector clockwise to lock the dust bag (20).

Pull the dust bag connector anticlockwise in a twisting motion to remove the dust bag (20)

### Emptying

Open the zip and empty chippings into a suitable rubbish bag.

Close the zip and re-attach the dust bag (20) to the product.

### Dust extraction

Alternatively a dust extraction system or suitable vacuum cleaner can be connected to the dust extraction outlet (10) for a cleaner and safer work area.

### PARALLEL GUIDE (D, E)

Attach the parallel guide (21) to the angle bracket (21a) as shown (D). Fix it with the mounting screw, wing nut (21b) and washer.

Align the hole in the angle bracket (21a) to the mounting thread (11) and fix them with the wing screw (18).

Loosen the wing nut (21b) and adjust the parallel guide (21) to the desired width. Then tighten the wing nut (21b).

### REBATE DEPTH GAUGE (F)

Attach the rebate depth gauge (19) and parallel guide (21) to perform rebate cuts.

Align the slot of the rebate depth gauge to the mounting thread and fix it with a wing screw. Adjust the rebate depth gauge to the desired depth then tighten the wing screw.



## USE

### 01 INTENDED USE

This product is intended for planing of firmly supported wooden materials, such as beams and boards. It is also suitable for bevelling edges and cutting rebates.

### 02 OPERATION

#### ON/OFF SWITCH (G)

Press and hold the lock-off button (4) then press the on/off button (5) to switch the product on. To switch the product off just release the on/off button.



**NOTE:** The lock-off button can be operated from either side to allow left or right handed use.

#### PLANING DEPTH

Adjust the desired planing depth by turning the cutting depth adjustment knob (2). The depth can be adjusted between 0 and 2mm. The number next to the pointer indicates the depth of cut in millimeters.

| Turn knob (2) | Position front plate (13)         | Planing depth | Blades (15)                     |
|---------------|-----------------------------------|---------------|---------------------------------|
|               | Retracted to maximum position<br> | Increased     | Fully lowered for maximum cut   |
|               | Lowered to minimum position<br>   | Decreased     | Fully retracted for minimum cut |

| Turn knob (2) | Position front plate (13)                     | Planing depth | Blades (15)            |
|---------------|---|---------------|------------------------|
|               | Lowered to "P" position (safety position)<br> | <0            | Fully retracted to < 0 |

#### PLANNING (H, I, J)



**NOTE:** Always make a trial cut before working on the actual workpiece, especially after replacing or adjusting the planing depth.

Adjust the desired planing depth.

Hold the product with one hand on the handle (6), and with the other hand on the cutting depth adjustment knob (2).

Switch the product on and wait until it runs at full speed before placing it on the workpiece.

Place the front plate (13) flat on the workpiece and push the product forward at an even speed.

Turn the cutting depth adjustment knob (2) for depth adjustment anticlockwise to retract the blades (15) after finishing your work.

#### BEVEL PLANING (K)

With the V-groove (12) bevel angles of 45° can be cut on the edge of a workpiece.

Place the V-groove (12) onto the edge of the workpiece. Guide the product along the edge.



**NOTE:** Apply slight consistent pressure against the parallel guide to achieve an even result.



**WARNING!** Danger of kickback! Apply the product to the workpiece only when switched on!

## STANDARD SURFACE PLANING WITH OR WITHOUT THE PARALLEL GUIDE (L, M)

Set the desired cutting depth. It is best to use small depths of cut and repeat the planing process.

Attach the parallel guide (21) if required to the product as described above and adjust to desired width.

Place the product laterally to the workpiece and guide the product along the edge.



**NOTE:** Apply light lateral supporting pressure against the parallel guide and keep the base plate flat on the surface to achieve an even result.



**WARNING!** Danger of kickback! Apply the product to the workpiece only when switched on!

## REBATE PLANING (N)

Attach the parallel guide (21) and rebate depth gauge (19) to the product as described above and adjust to desired width and depth.

Place the product laterally against the workpiece.

Guide the product along the edge, repeat until the desired depth has been reached.



**NOTE:** Apply light lateral supporting pressure against the parallel guide and keep the base plate flat on the surface to achieve an even result.



**WARNING!** Danger of kickback! Apply the product to the workpiece only when switched on!

## OVERLOAD, TEMPERATURE AND CHARGING PROBLEM

| Problem                    | Tool/ Battery Status   | Possible cause  | Solution   |
|----------------------------|--|---|--|
| Overload protection        | Product suddenly Stops; The LED work light (if fitted) is flashing                   | Extremely high torque, binding and stalling situations, overloading of the tool | Relieve the load immediately, reset the tool by switching off and back on again.   |
| Temperature extremely high | The first and the third LED light of the POWER BAR will be flashing alternately      | Battery temperature exceeds 77°C during operation                               | Cool down the battery to below 77°C for operation and below 57°C for charging.   |
| Low charge                 | Power for the tool will drop quickly; The first LED on the POWER BAR begins to flash | The battery pack is under 5% charge   | Remove the battery pack from the tool and charge it  |
| Other problems             | Short charges  | Not fully charged   | Make sure that the battery is fully charged every time by allowing the charger to complete its full charging cycle   |
|                            |  | Poor storage condition  | Always remove battery from the tool and charger when not in use and store in a dry secure place. Avoid charging or storing your battery in temperatures below 5°C and above 40°C. Cool down a hot battery pack from a tool that has just been operated for approximately 30 minutes before storage |





## CARE & MAINTENANCE

### CLEANING DUST EXTRACTION OUTLET

Free the dust extraction outlet (10) from blockages and dust using a suitable tool such as a piece of wood or use high pressure air.



**WARNING!** Never insert your bare fingers into the outlet! Never hold a finger or any other part of your body in the chip ejector opening. Always clean a blocked chip ejector opening with a suitable tool such as a wooden stick!

### BLADES REPLACEMENT



**WARNING!** Always ensure to work with sharp blades. Replace worn or damaged blades immediately! Dull and worn blades cannot be reground and must be replaced. Observe the technical requirements of this product (see section Technical specifications) when purchasing and using replacement blades! Blades are very sharp and become hot during use! Handle them carefully! Wear protective gloves when handling blades in order to avoid injuries like burns and cuts!

### Removal (O1, O2)



**WARNING!** Always replace both blades at the same time! Do not mix old and new blades or blades of different types or brands!

Lay the product on a flat surface so that you have free access to the bottom side.

Turn the roller (14) until the blade shaft is adjusted between the plates.

Loosen the hex screws (23) slightly anticlockwise using the wrench (22).

Push the blade (15) slightly with a piece of wood and then pull it out using a proper tool, e.g. pliers.

Clean all parts carefully to clear dust.



**WARNING!** Always use a suitable tool to pull the blade out! Do not try to pull out with bare hands!

### Re-assembly (P)



**NOTE:** Usually planing blades can be used from two sides. For the first replacement turn the blade vertically 180° and re-fit it. If both sides of a blade are worn out, replace with a new pair of blades.

Slide the blade between the blade fixing element and cutter block (25). Be sure the orientation of the blade is correct and it is positioned centrally.

Tighten the hex screws (23) clockwise until the blade is clamped tightly.



**NOTE:** The planing surface will end up rough and uneven unless the blades are set properly and securely. The blades must be mounted so that the cutting edge is absolutely level, e.g. parallel to the surface of the back plate.

The following examples show proper and improper settings:

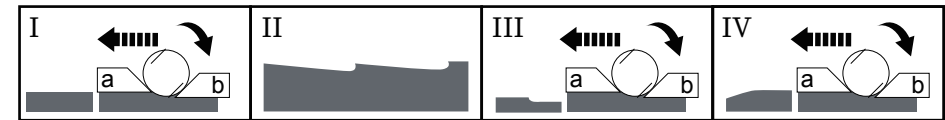

a= Adjustable front plate (13), b= Fixed back plate (16)

Fig. I – Clean smooth cut.

Fig. II – Nicks in surface – as caused by the edge of one or all blades not being parallel to the rear base line.

Fig. III – Gouging at start – as caused by the edge of one or all blades not protruding enough in relation to the rear base line.

Fig. IV – Gouging at end – as caused by the edge of one or all blades protruding too far in relation to the rear base line.

### CUTTER BLOCK (Q)

The height is pre-set in the factory and normally there is no need to re-adjust. Nevertheless check whether the front plate (13) runs parallel to the roller edge occasionally. If necessary adjust the height with the hex key (26).

Loosen the hex screws (23).

Turn the grub screws (24) clockwise to increase the height.

Turn the grub screws anticlockwise to decrease the height.

### MAINTENANCE

Your tool requires no additional lubrication or maintenance. There are no user serviceable parts in your power tool. Never use water or chemical cleaners to clean your power tool. Wipe clean with a dry cloth. Always store your power tool in a dry place. Keep the motor ventilation slots clean. Keep all working controls free of dust.

## RECYCLING AND DISPOSAL



Waste electrical products should not be disposed of with household waste. Please recycle where facilities exist. Check with your Local Authority or retailer for recycling advice.

For further information visit [www.recycle-more.co.uk](http://www.recycle-more.co.uk)

## DISPOSAL OF AN EXHAUSTED BATTERY PACK



To preserve natural resources, please recycle or dispose of the battery pack properly. This battery pack contains Li-Ion batteries. Consult your local waste authority for information regarding available recycling and/or disposal options. Discharge your battery pack by operating your tool, then remove the battery pack from the tool housing and cover the battery pack connections with heavy-duty adhesive tape to prevent short circuit and energy discharge. Do not attempt to open or remove any of the components.

## REPAIR

This product does not contain any parts that can be repaired by the consumer. Contact an authorised service centre or a similarly qualified person to have it checked and repaired.

## STORAGE

- Switch the product off and remove the battery pack.
- Clean the product as described above.
- Store the product and its accessories in a dark, dry, frost-free, well-ventilated place.
- Always store the product in a place that is inaccessible to children.
- We recommend using the original package for storage or covering the product with a suitable cloth or enclosure to protect it against dust.

## TRANSPORTATION

- Switch the product off and remove the battery pack.
- Attach transportation guards, if applicable.
- Always carry the product by its handle.
- Protect the product from any heavy impact or strong vibrations which may occur during transportation in vehicles.
- Secure the product to prevent it from slipping or falling over.



## GUARANTEE

At **Erbauer** we take special care to select high quality materials and use manufacturing techniques that allow us to create ranges of products incorporating design and durability. That's why we offer a 2 year trade guarantee against manufacturing defects on our **Erbauer** power tool products.

This power tool is guaranteed for 2 years from the date of purchase, if bought in store, delivered or bought online. You may only make a claim under this guarantee upon presentation of your sales receipt or purchase invoice. Please keep your proof of purchase in a safe place.

This guarantee covers product failures and malfunctions provided the **Erbauer** power tool was used for the purpose for which it is intended and subject to installation, cleaning, care and maintenance in accordance with standard practice and with the information contained above and in the user manual. This guarantee does not cover defects and damage caused by or resulting from:

- Normal wear and tear, including accessory wear
- Overload, misuse or neglect
- Repairs attempted by anyone other than an authorised agent
- Cosmetic damage
- Damage caused by foreign objects, substances or accidents
- Accidental damage or modification
- Failure to follow manufacturer's guidelines
- Loss of use of the goods

This guarantee is limited to parts recognised as defective. It does not, in any case, cover ancillary costs (movement, labour) and direct and indirect damage.

If the **Erbauer** power tool is defective during the guarantee period, then we reserve the right, at our discretion, to replace the item with a product of equivalent quality and functionality or to provide a refund.

This guarantee only applies to the country of purchase or delivery and is not transferrable to any other countries. This guarantee is non-transferrable to any other person or product. Relevant local law will apply to this guarantee.

Guarantee related queries should be addressed to a store affiliated with the distributor you purchased the **Erbauer** power tool from.

This guarantee is in addition to and does not affect your statutory rights relating to faulty goods as a consumer.



## DECLARATION OF CONFORMITY



### EU Declaration of Conformity

**We**  
**Kingfisher International Products Limited**  
**3 Sheldon Square**  
**London W2 6PX**  
**United Kingdom**

Declare that the product:  
Erbauer 18V cordless planer EHP18-Li  
Serial number 00001-99999

Complies with the essential health and safety requirements of the following directives:

2006/42/EC The Machinery Directive  
References to the following harmonized standard were made:

EN62841-1:2015  
EN62841-2-14:2015

2014/30/EU Electromagnetic Compatibility directive  
References to the following harmonized standard were made:

EN 55014-1:2017  
EN 55014-2:2015

(EU) 2015/863 amending 2011/65/EU Restrictions of the Use of Certain Hazardous Substances in  
Electrical and Electronic Equipment

Authorised signatory and technical file holder:

Kingfisher International Products Limited  
3 Sheldon Square  
London W2 6PX  
United Kingdom

on: 18/06/2018

Lisa Davis  
Group Quality Director

**Manufacturer • Fabricant • Producent • Hersteller • Producator • Fabricante:**

Kingfisher International Products Limited  
3 Sheldon Square London W2 6PX  
United Kingdom  
[www.kingfisher.com/products](http://www.kingfisher.com/products)

**EN DISTRIBUTOR:**

B&Q plc,  
Chandlers Ford, Hants, SO53 3LE  
United Kingdom  
[www.diy.com](http://www.diy.com)

Screwfix Direct Limited,  
Trade House, Mead Avenue,  
Yeovil, BA22 8RT, United Kingdom  
[www.screwfix.com](http://www.screwfix.com)

To view instruction manuals online,  
visit [www.kingfisher.com/products](http://www.kingfisher.com/products)