

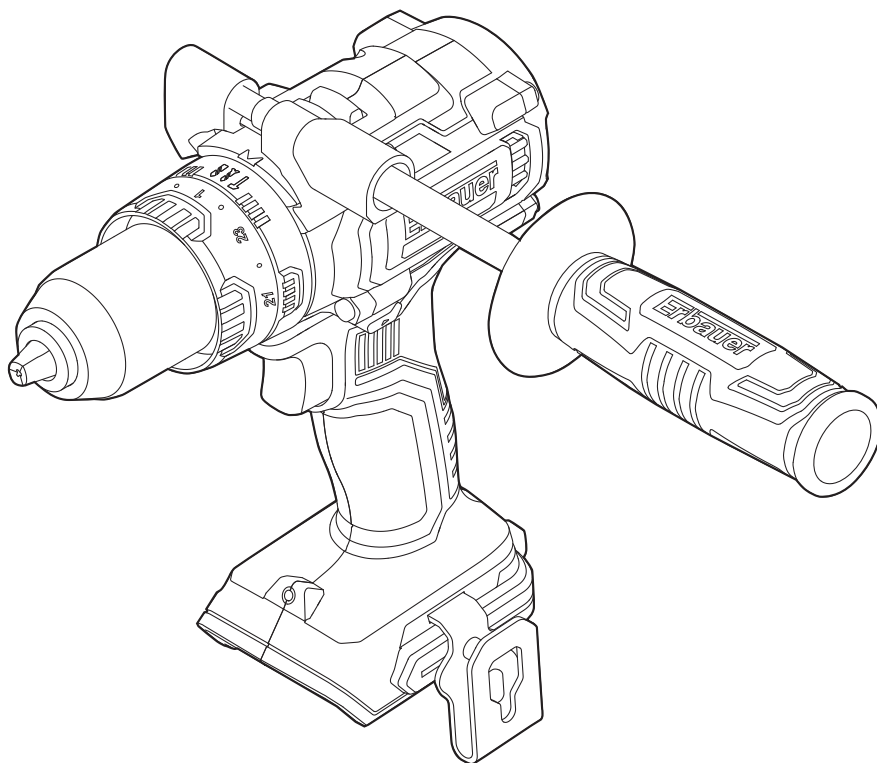

**Erbauer**



MNL\_ECDT18-Li-2\_V01\_180608

EAN. 3663602799177

# ECDT18-Li-2

ORIGINAL INSTRUCTIONS

EN



Safety instructions



Product description



Assembly



Use



+



Care & maintenance



Guarantee



Declaration of Conformity



**WARNING!** Please read all safety warnings carefully and be sure that they are fully understood before handling the tool.

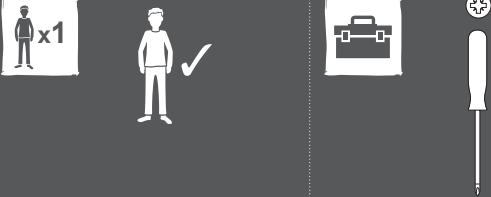
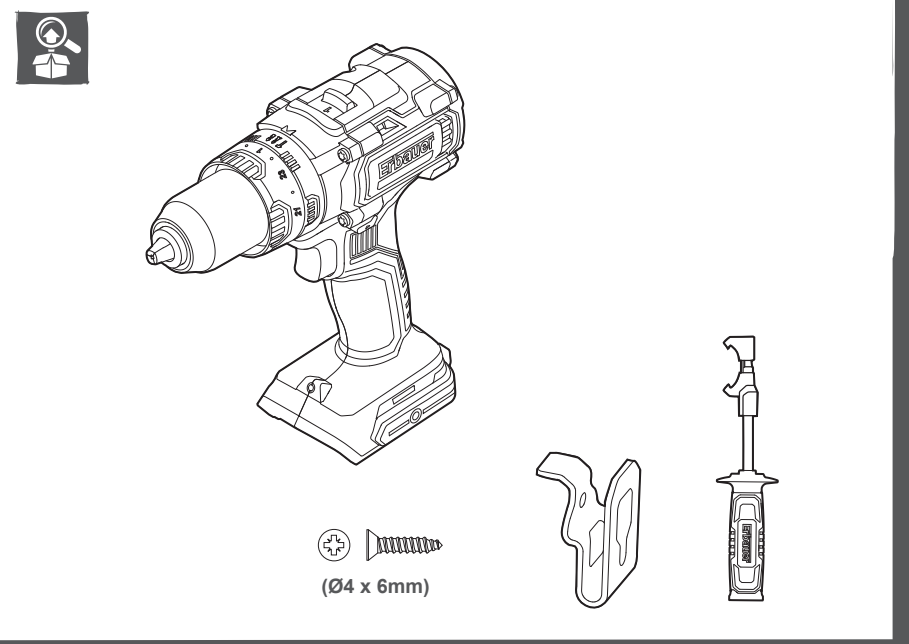



(Ø4 x 6mm)

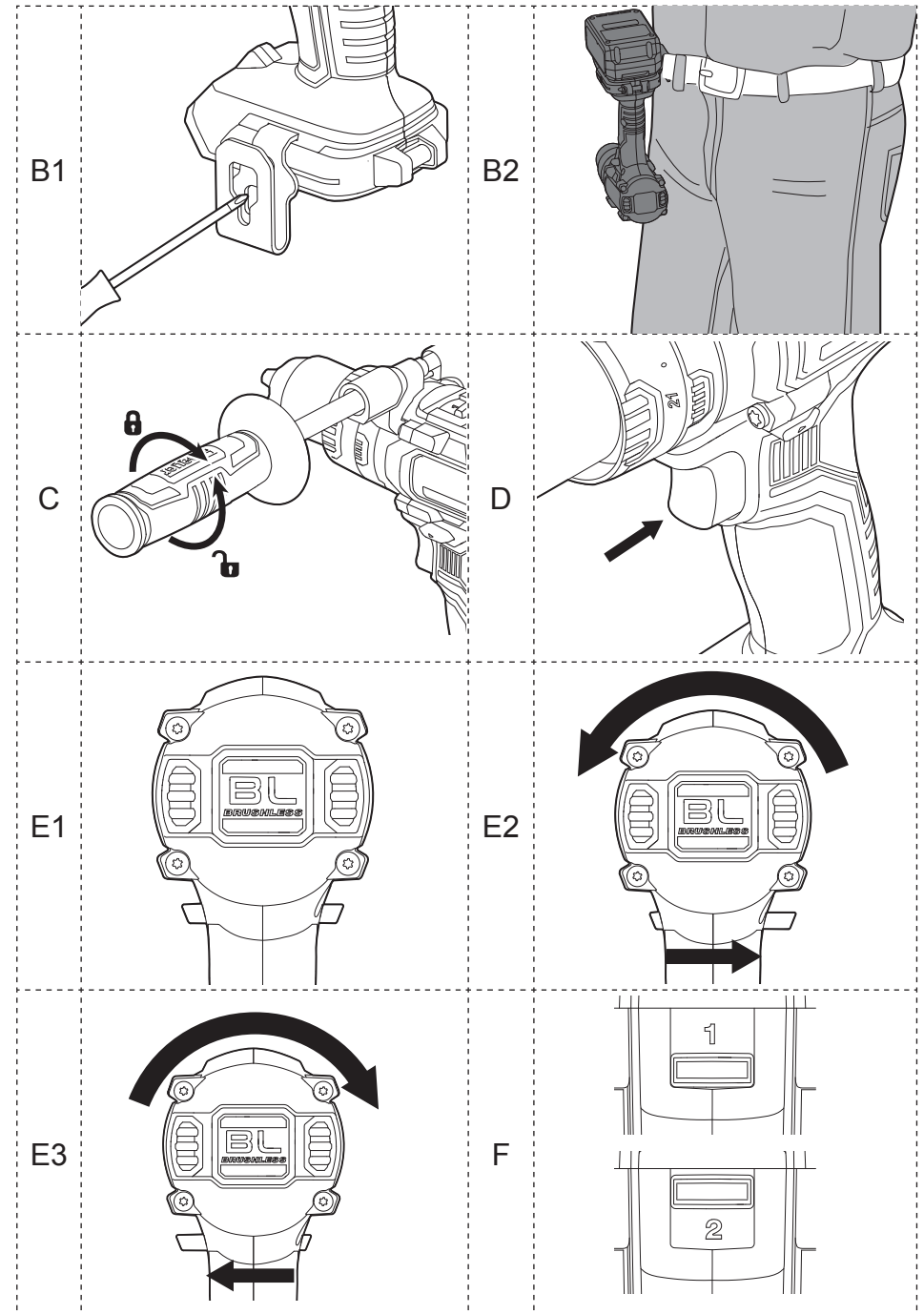
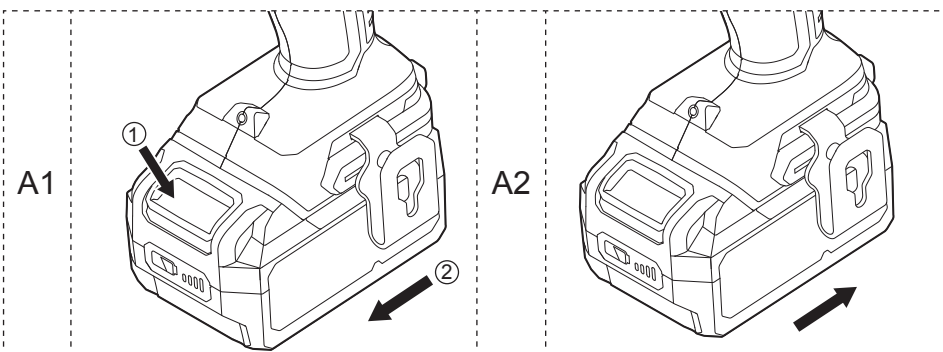
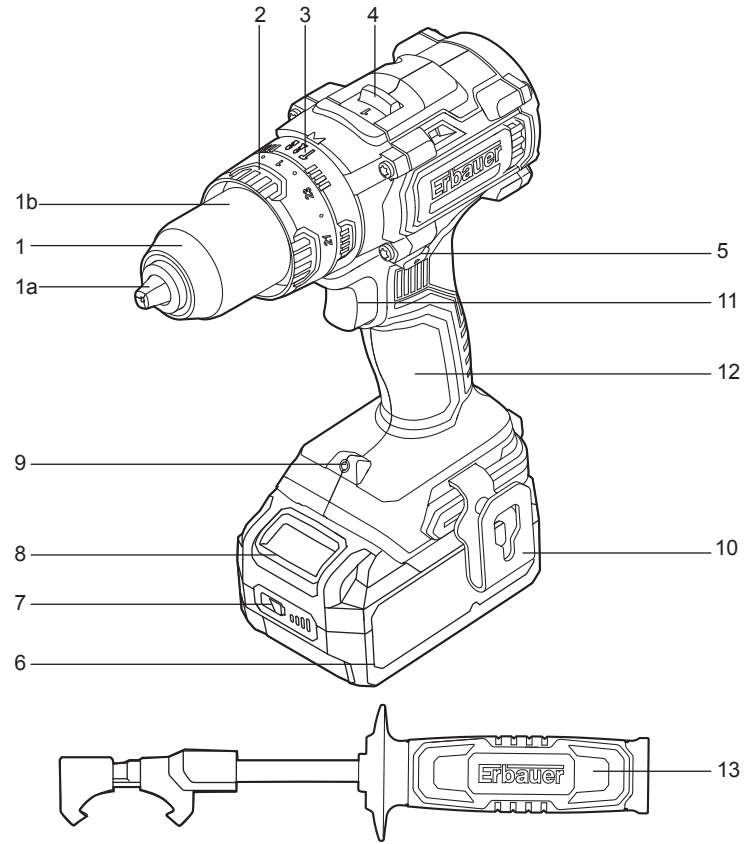

# PRODUCT DESCRIPTION

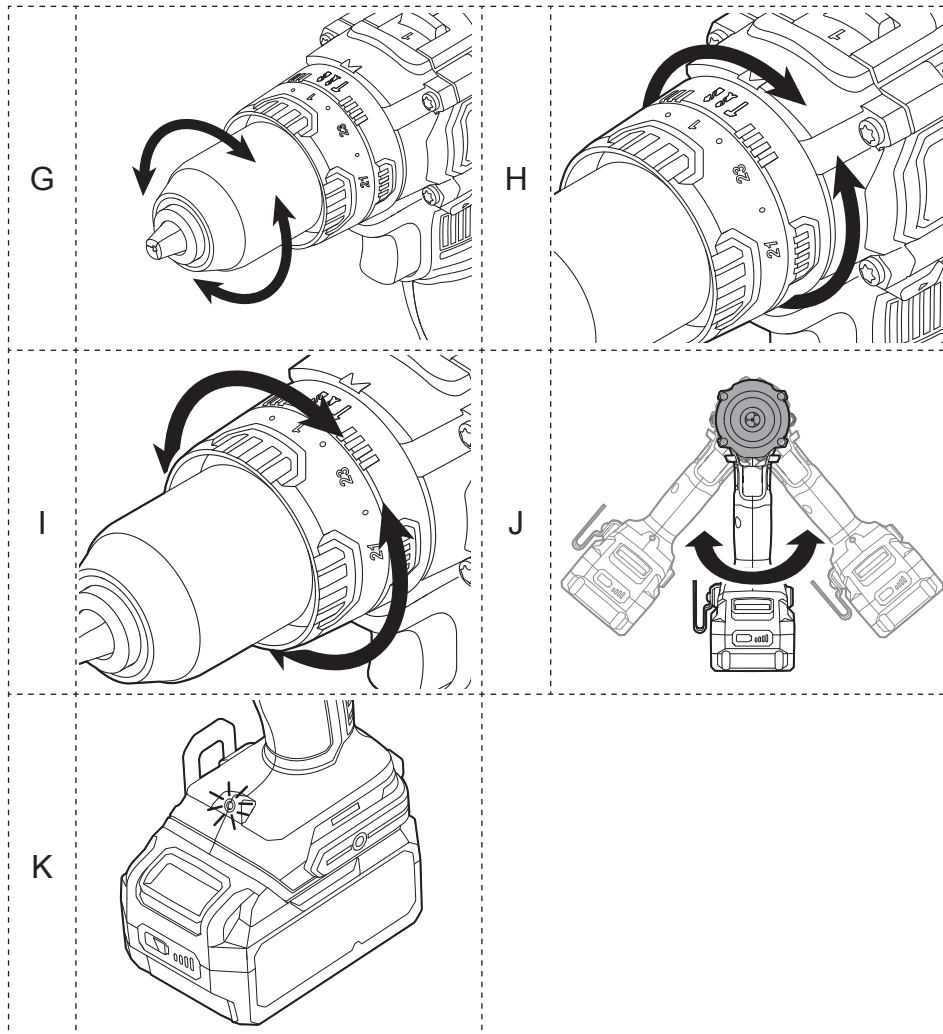



## SAFETY INSTRUCTIONS

### GENERAL POWER TOOL SAFETY WARNINGS



**WARNING!** Read all safety warnings, instructions, illustrations and specifications provided with this power tool. Failure to follow all instructions listed below may result in electric shock, fire and/or serious injury.

**Save all warnings and instructions for future reference. The term “power tool” in the warnings refers to your mains-operated (corded) power tool or battery operated (cordless) power tool.”**

### WORK AREA SAFETY

- Keep work area clean and well lit. Cluttered or dark areas invite accidents.
- Do not operate power tools in explosive atmospheres, such as in the presence of flammable liquids, gases or dust. Power tools create sparks which may ignite the dust or fumes.
- Keep children and bystanders away while operating a power tool. Distractions can cause you to lose control.

### ELECTRICAL SAFETY

- Power tool plugs must match the outlet. Never modify the plug in any way. Do not use any adapter plugs with earthed (grounded) power tools. Unmodified plugs and matching outlets will reduce risk of electric shock.
- Avoid body contact with earthed or grounded surfaces, such as pipes, radiators, ranges and refrigerators. There is an increased risk of electric shock if your body is earthed or grounded.

- c. **Do not expose power tools to rain or wet conditions.** *Water entering a power tool will increase the risk of electric shock.*
- d. **Do not abuse the cord. Never use the cord for carrying, pulling or unplugging the power tool. Keep cord away from heat, oil, sharp edges or moving parts.** *Damaged or entangled cords increase the risk of electric shock.*
- e. **When operating a power tool outdoors, use an extension cord suitable for outdoor use.** *Use of a cord suitable for outdoor use reduces the risk of electric shock.*
- f. **If operating a power tool in a damp location is unavoidable, use a residual current device (RCD) protected supply.** *Use of an RCD reduces the risk of electric shock.*

## PERSONAL SAFETY

- a. **Stay alert, watch what you are doing and use common sense when operating a power tool. Do not use a power tool while you are tired or under the influence of drugs, alcohol or medication.** *A moment of inattention while operating power tools may result in serious personal injury.*
- b. **Use personal protective equipment. Always wear eye protection.** *Protective equipment such as a dust mask, non-skid safety shoes, hard hat, or hearing protection used for appropriate conditions will reduce personal injuries.*
- c. **Prevent unintentional starting. Ensure the switch is in the off- position before connecting to power source and/or battery pack, picking up or carrying the tool.** *Carrying power tools with your finger on the switch or energising power tools that have the switch on invites accidents.*
- d. **Remove any adjusting key or wrench before turning the power tool on.** *A wrench or a key left attached to a rotating part of the power tool may result in personal injury.*
- e. **Do not overreach. Keep proper footing and balance at all times.** *This enables better control of the power tool in unexpected situations.*

- f. **Dress properly. Do not wear loose clothing or jewellery. Keep your hair, clothing away from moving parts.** *Loose clothes, jewellery or longhair can be caught in moving parts.*
- g. **If devices are provided for the connection of dust extraction and collection facilities, ensure these are connected and properly used.** *Use of dust collection can reduce dust-related hazards.*
- h. **Do not let familiarity gained from frequent use of tools allow you to become complacent and ignore tool safety principles.** *A careless action can cause severe injury within a fraction of a second.*

## POWER TOOL USE AND CARE

- a. **Do not force the power tool. Use the correct power tool for your application.** *The correct power tool will do the job better and safer at the rate for which it was designed.*
- b. **Do not use the power tool if the switch does not turn it on and off.** *Any power tool that cannot be controlled with the switch is dangerous and must be repaired.*
- c. **Disconnect the plug from the power source and/or remove the battery pack, if detachable, from the power tool before making any adjustments, changing accessories, or storing power tools.** *Such preventive safety measures reduce the risk of starting the power tool accidentally.*
- d. **Store idle power tools out of the reach of children and do not allow persons unfamiliar with the power tool or these instructions to operate the power tool.** *Power tools are dangerous in the hands of untrained users.*
- e. **Maintain power tools and accessories. Check for misalignment or binding of moving parts, breakage of parts and any other condition that may affect the power tools operation. If damaged, have the power tool repaired before use.** *Many accidents are caused by poorly maintained power tools.*

- f. **Keep cutting tools sharp and clean.** *Properly maintained cutting tools with sharp cutting edges are less likely to bind and are easier to control*
- g. **Use the power tool, accessories and tool bits etc. in accordance with these instructions, taking into account the working conditions and the work to be performed.** *Use of the power tool for operations different from those intended could result in a hazardous situation.*
- h. **Keep handles and grasping surfaces dry, clean and free from oil and grease.** *Slippery handles and grasping surfaces do not allow for safe handling and control of the tool in unexpected situations.*

#### BATTERY TOOL USE AND CARE

- a. **Recharge only with the charger specified by the manufacturer.** *A charger that is suitable for one type of battery pack may create a risk of fire when used with another battery pack.*
- b. **Use power tools only with specifically designated battery packs.** *Use of any other battery packs may create a risk of injury and fire.*
- c. **When battery pack is not in use, keep it away from other metal objects, like paper clips, coins, keys, nails, screws or other small metal objects, that can make a connection from one terminal to another.** *Shorting the battery terminals together may cause burns or a fire.*
- d. **Under abusive conditions, liquid may be ejected from the battery; avoid contact. If contact accidentally occurs, flush with water. If liquid contacts eyes, additionally seek medical help.** *Liquid ejected from the battery may cause irritation or burns.*
- e. **Do not use battery pack or tool that is damaged or modified.** *Damaged or modified batteries may exhibit unpredictable behaviour resulting in fire, explosion or risk of injury.*

- f. **Do not expose a battery pack or tool to fire or excessive temperature.** *Exposure to fire or temperature above 130 °C may cause explosion.*
- g. **Follow all charging instructions and do not charge the battery pack or tool outside the temperature range specified in the instructions.** *Charging improperly or at temperatures outside the specified range may damage the battery and increase the risk of fire.*

#### SERVICE

- a. **Have your power tool serviced by a qualified repair person using only identical replacement parts.** *This will ensure that the safety of the power tool is maintained.*
- b. **Never service damaged battery packs.** *Service of battery packs should only be performed by the manufacturer or authorized service providers.*

#### ADDITIONAL SAFETY WARNINGS FOR YOUR COMBI DRILL

- a. **Wear ear protectors when use impact drilling.** *Exposure to noise can cause hearing loss.*
- b. **Use auxiliary handle(s), if supplied with the tool.** *Loss of control can cause personal injury.*
- c. **Brace the tool properly before use.** *This tool produces a high output torque and without properly bracing the tool during operation, loss of control may occur resulting in personal injury.*
- d. **Hold power tool by insulated gripping surfaces, when performing an operation where the cutting accessory/fastener may contact hidden wiring.** *Cutting accessory/fastener contacting a "live" wire may make exposed metal parts of the power tool "live" and could give the operator an electric shock.*
- e. *Always check walls, floors and ceilings for hidden power cables and pipes.*

## ADDITIONAL SAFETY WARNINGS FOR BATTERY

- a. *Do not connect the positive terminal and negative terminal of the battery to each other with any metal object (such as wire).*
- b. *Do not carry or store battery together with necklaces, hairpins or other metal objects.*
- c. *Do not pierce the battery with nails, strike the battery with a hammer, step on the battery or otherwise subject it to strong impacts or shocks.*
- d. *Do not solder directly onto the battery.*
- e. *Do not expose battery to water or salt water, or allow the battery to get wet.*
- f. *Do not disassemble or modify the battery.*
- g. *Do not place the battery in or near fire, on stoves or other high temperature locations. Do not place the battery in direct sunlight, or use or store the battery inside cars in hot weather.*
- h. *Do not place the battery in microwave ovens, high-pressure containers or on induction cookware.*
- i. *If you intend to store a battery for a period without use then store battery at room temperature (19°C to 25°C), charged to about 30 – 50% of capacity. When storing for very long periods boost charge the battery once per year to prevent over discharge.*

The following information applies to professional users only but is good practice for all users:

## ADDITIONAL SAFETY WARNING FOR CONSTRUCTION DUST

The updated Control of Substances Hazardous to Health Regulations 1st October 2012 now also targets to reduce the risks associated with silica, wood and gypsumdusts. Construction workers are one of the at-risk groups within this because of the dust that they breathe: silica dust is not just a nuisance; it is a real risk to your lungs!

Silica is a natural mineral present in large amounts in things like sand, sandstone and granite. It is also commonly found in many construction materials such as concrete and mortar. The silica is broken into very fine dust (also known as Respirable Crystalline Silica or RCS) during many common tasks such as cutting, drilling and grinding. Breathing in very fine particles of crystalline silica can lead to the development of: Lung cancer Silicosis Chronic Obstructive Pulmonary Disorder/Chronic obstructive pulmonary disease (COPD) And breathing in fine particles of wood dust can lead to the development of Asthma. The risk of lung disease is linked to people who regularly breathe construction dust over a period of time, not on the odd occasion.

To protect the lung, the COSHH Regulations sets a limit on the amount of these dusts that you can breathe (called a Workplace Exposure Limit or WEL) when averaged over a normal working day. These limits are not a large amount of dust: when compared to a penny it is tiny – like a small pinch of salt: This limit is the legal maximum; the most you can breathe after the right controls have been used.

## HOW TO REDUCE THE AMOUNT OF DUST?

1. Reduce the amount of cutting by using the best sizes of building products. Use a less powerful tool e.g. a block cutter instead of angle grinder.
2. Using a different method of work altogether – e.g. using a nail gun to direct fasten cable trays instead of drilling holes first.
3. Please always work with approved safety equipment, such as those dust masks that specially designed to filter out microscopic particles and use the dust extraction facility at all time.

For more information please see the HSE website: <http://www.hse.gov.uk/construction> or <http://www.hse.gov.uk/pubns/cis69.pdf>



**WARNING!** Some dust particles created by power sanding, sawing, grinding, drill and other construction jobs contain chemicals known to cause cancer, birth defects or other reproductive harm. Some examples of these chemicals are:

- Lead from lead-based paints.
- Crystalline silica from bricks and cement and other masonry products.
- Arsenic and chromium from chemically treated timber.
- Your risk from these exposures varies, depending upon how often you do this type of work. To reduce your exposure to these chemicals:
- Work in a well-ventilated area.
- Work with approved safety equipment, such as those dust masks that are specially designed to filter microscopic particles

## VIBRATION

The European Physical Agents (Vibration) Directive has been brought in to help reduce hand arm vibration syndrome injuries to power tool users. The directive requires power tool manufacturers and suppliers to provide indicative vibration test results to enable users to make informed decisions as to the period of time a power tool can be used safely on a daily basis and the choice of tool.

### SEE TECHNICAL SPECIFICATIONS IN THE INSTRUCTION MANUAL FOR THE VIBRATION LEVELS OF YOUR TOOL.

The declared vibration emission value should be used as a minimum level and should be used with the current guidance on vibration.

Calculating the actual period of use can be difficult and the HSE website has further information.

The declared vibration emission been measured in accordance with EN60745-1,EN60745-2-1 and may be used to compare one tool with another tool. The declared vibration emission value may also be used in preliminary assessment of exposure.



**WARNING!** The vibration emission value during actual use of the power tool can differ from the declared value depending on the ways in which the tool is used dependant on the following examples and other variations on how the tool is used:

- How the tool is used and the materials being cut or drilled.
- The tool being in good condition and well maintained.
- Use the correct accessories for the tool and ensure they are sharp and in good condition.
- The tightness of the grip on the handles.
- The tool is being used as intended by its design and these instructions.



**WARNING!** Identify safety measures to protect the operator that are based on an estimation of exposure in the actual conditions of use (taking account of all parts of the operating cycle such as the times when the tool is switched off and when it is running idle in addition to the trigger time).

While working with this power tool, hand/arm vibrations occur. Adopt the correct working practices in order to reduce the exposure to vibration. This tool may cause hand-arm vibration syndrome if its use is not adequately managed.

Helping to minimise your vibration exposure risk. ALWAYS use sharp chisels, drills and blades. Maintain this tool in accordance with these instructions and keep well lubricated (where appropriate).



Avoid using tools in temperatures of 10°C or less. Plan your work schedule to spread any high vibration tool use across a number of days.



**NOTE:** The use of other tools will reduce the users' total working period on this tool.

## HEALTH SURVEILLANCE

All employees should be part of an employer's health surveillance scheme to help identify any vibration related diseases at an early stage, prevent disease progression and help employees stay in work.

## RESIDUAL RISKS

**Even if you are operating this product in accordance with all the safety requirements, potential risks of injury and damage remain. The following dangers can arise in connection with the structure and design of this product:**

1. Injuries and damage to property due to broken attachments or the sudden impact of hidden objects during use.
2. Danger of injury and property damage caused by flying objects or poor power tool accessories.



## PRODUCT DESCRIPTION

1. Keyless chuck
  - 1a. Chuck jaws
  - 1b. Chuck sleeve
2. Torque adjustment ring
3. Function selection ring
4. Two-speed gear control
5. Forward/reverse rotation control
6. Battery pack (not included)
7. Power bar button
8. Battery pack release button
9. LED work light
10. Belt clip
11. On/off switch
12. Handle
13. Auxiliary handle

## 01 TECHNICAL SPECIFICATIONS

### Drill

Rated voltage:	18V d.c.
Rated no load speed:	0-550/0-2000/min
Impact rate:	0-8800/0-32000/min
Clutch position:	24+1+1
Max. torque:	120 N.m
Chuck capacity:	13mm
Max. drilling capacity:	<ul style="list-style-type: none"> <li>• Wood 35mm</li> <li>• Steel 13mm</li> <li>• Masonry 16mm</li> </ul>
Weight(without battery):	1.8 kg

### For use with battery pack and charger as below:

Battery pack model: EBAT18-Li-2 / EBAT18-Li-4 / EBAT18-Li-5

Charger model: EC18-Li / EFC18-Li / EMC18-Li

Ambient temperature range for tool and battery use: -10°C to 40°C

**NOISE DATA**

A weighted sound pressure:

$L_{pA}=92.5\text{dB(A)}$

A weighted sound power:

$L_{WA}=103.5\text{dB(A)}$

Uncertainty:

$K_{PA} \& K_{WA}=3.0\text{dB(A)}$

The sound emission values have been obtained according to the noise test code given in EN 60745-1 and EN 60745-2-1.

The noise for the operator may exceed 80 dB(A) and ear protection measures are necessary.

**VIBRATION DATA**

Impact drilling into concrete:

$a_{h,1D}= 11.0\text{m/s}^2$

Drilling into metal:

$a_{h,D}= 1.6\text{m/s}^2$

Uncertainty

$K=1.5\text{m/s}^2$

**RATING LABEL EXPLANATION****ECDT18-Li-2 = MODEL NUMBER****E** = ERBAUER**CD** = COMBI DRILL**T** = Trade use**18** = 18 V d.c.**Li** = LITHIUM ION**2** = 2 SPEED**ASSEMBLY****01 SYMBOLS**

Read the instruction manual



Wear eye protection



Wear hearing protection.



Wear a dust mask.



Do not dispose of battery packs in rivers or immerse in water.



Do not dispose of battery packs in fire. They will explode and cause injury.



Do not expose battery packs to heat in excess of 40°C



Brushless motor



Keep Cool Battery Technology

yyWxx

Manufacturing date code: Year of manufacturing (20yy) and week of manufacturing (Wxx)

## 02 UNPACKING

Unpack all parts and lay them on a flat, stable surface.

- Remove all packing materials and shipping devices, if applicable.
- Make sure the delivery contents are complete and free of any damage. If you find that parts are missing or show damage do not use the product but contact your dealer. Using an incomplete or damaged product represents a hazard to people and property.
- Ensure that you have all the accessories and tools needed for assembly and operation. This also includes suitable personal protective equipment



**WARNING!** The product and the packaging are not children's toys! Children must not play with plastic bags, sheets and small parts! There is a danger of choking and suffocation!

## 03 ASSEMBLING THE MACHINE

### CHARGING YOUR BATTERY PACK







The battery has been shipped in a low charge condition. Charge it fully before first use. Refer to the charger instruction manual for the details.

### TO REMOVE OR INSTALL THE BATTERY PACK (A1, A2)

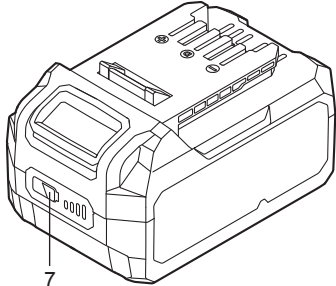
Depress the battery pack release button to release and slide the battery pack out from your tool. After recharge, slide it back into your tool. A simple push and slight pressure will be sufficient.

## BATTERY PACK POWER BAR

The Li-Ion battery pack (6) is equipped with a POWER BAR which is used to give an indication of the battery pack's remaining charge. Press the POWER BAR button (7) to check battery charge as below. The LED will stay lit for approximately 5 seconds.

 7	76-100% Charge	
	51-75% Charge	
	26-50% Charge	
	5-25% Charge	
	under 5% Charge	
Flash	On	Off

### HOW TO USE THE BELT CLIP (B1, B2)

Screw the Belt clip (10) on the tool with the screw. The Belt clip can be hooked on your belt or pocket, etc.

### AUXILIARY HANDLE (C)

Fix the auxiliary handle onto the hammer drill before working. To clamp the auxiliary handle, rotate the handle clockwise. To loosen the auxiliary handle, rotate the handle anti-clockwise.



**WARNING!** This tool generates high levels of torque. Never operate the product without the auxiliary handle to avoid accidents and injury! Always ensure that the auxiliary handle is attached and secured correctly before operation! The auxiliary handle provides better control of the product in case of sudden jams during use when considerable forces are released!



## USE

### 01 INTENDED USE

This product is intended for drilling in wood and similar materials e.g. MDF, plywood etc, plastic, metal and impact drilling in brick, tile, concrete, as well as for screw driving.

### 02 OPERATION

#### ON / OFF SWITCH (D)

Depress the on/off switch (11) to start and release it to stop your drill. The on/ off switch is fitted with a brake function which stops your chuck immediately when you quickly release the switch. It is also a variable speed switch that delivers higher speed and torque with increased trigger pressure.



**WARNING!** Do not operate for long periods at low speed because excess heat will be produced internally.

#### SWITCH LOCK (E1)

The switch trigger can be locked in the OFF position. This helps to reduce the possibility of accidental starting when not in use. To lock the switch trigger, place the rotation control (5) in the centre position.

#### FORWARD/REVERSE ROTATION CONTROL (E2, E3)



**WARNING!** Only change the rotational direction when the product is switched off and has come to a complete stop! Always ensure that the forward / reverse rotation control is adjusted to the correct position depending on the intended operation!

Always push the forward / reverse rotation control as far as it will go! Do not use the product with the control switch in any other intermediate position!

Move the forward / reverse rotation control (5) to the left in order to use the product in a clockwise rotational mode.

Move the forward / reverse rotation control (5) to the right in order to use the product in anticlockwise rotational mode.

#### TWO-SPEED GEAR CONTROL (F)

The drill has a two-speed gear control designed for drilling or driving at LOW or HIGH speeds. A slide switch is located on top of the drill to select either LOW or HIGH speed. When using the drill in the LOW speed range, the speed will decrease and the drill will have greater power and torque. When using the drill in the HIGH speed range, the speed will increase and the drill will have less power and torque.

#### GEAR 1

Low speed range: for screw driving or working with large drilling diameter.

#### GEAR 2

High speed range: for working with small drilling diameter

#### BIT FITTING/REMOVING (G)

To fit a bit, loosen chuck sleeve to open chuck jaws. Insert the drill bit between the chuck jaws and tighten chuck sleeve fully. Ensure the drill bit is in the centre of the chuck jaws. To remove the bit, just loosen the chuck sleeve.

#### DRILL/SCREWDRIVER/HAMMER SELECTION RING (H)

Three working modes are available on this tool: drilling, screw driving and impact drilling. To select any of the three modes, rotate the function ring to align it with icon of the drill/ screwdriver/ hammer on the housing, depending on the function you require.

▩ For screw driving

▩ For drilling in wood and metal

➡ For impact drilling masonry and concrete

#### TORQUE ADJUSTMENT (I)

In screw driving mode, the torque can be adjusted by rotating the torque adjustment ring. Higher number means higher torque. Select the setting as follows:

1-5 for driving small screws

6-10 for driving screws into soft material

11-15 for driving screws into soft and hard material

16-20 for driving screws into hard wood

21-24 for driving larger screws

### AUTOMATIC SPINDLE LOCK (J)

The automatic spindle lock allows you to use it as a regular screwdriver. You can give an extra twist to firmly tighten a screw, loosen a very tight screw or continue working when the battery energy has expired. For manual screwdriver purposes, the chuck is automatically locked when the tool is off.

### AUTOMATIC LED WORK LIGHT (K)

The LED work light (9) will illuminate when the trigger switch is depressed slightly, and will automatically turn off a short while after the trigger switch is released. This provides additional light on the surface of the workpiece for operation in lower light situations.



**WARNING!** Do not look directly into LED light.

### DRILLING

When drilling into a hard smooth surface, use a centre punch to mark the desired hole location. This will prevent the drill bit from slipping off centre as the hole is started. Hold the tool firmly and place the tip of the bit at the point to be drilled. Depress the switch trigger to start the tool. Move the drill bit into the workpiece, applying only enough pressure to keep the bit rotating. Do not force or apply side pressure to elongate a hole.



**WARNING!** Tungsten carbide drill bits should always be used for concrete and masonry. When drilling in metal, only use HSS drill bits in good condition. Always use a magnetic bit holder (not included) when using short screwdriver bits. When screw-driving, apply a small quantity of liquid soap or similar to the screw threads to ease insertion.

Where possible, secure smaller work pieces to prevent them from moving during operation.

### OVERLOAD, TEMPERATURE AND CHARGING PROBLEM

Problem	Tool/ Battery Status	Possible cause	Solution
Overload protection	Product suddenly Stops; The LED work light (if fitted) is flashing	Extremely high torque, binding and stalling situations, overloading of the tool	Relieve the load immediately, reset the tool by switching off and back on again.
Temperature extremely high	The first and the third LED light of the POWER BAR will be flashing alternately	Battery temperature exceeds 77°C during operation	Cool down the battery to below 77°C for operation and below 57°C for charging.
Low charge	Power for the tool will drop quickly; The first LED on the POWER BAR begins to flash	The battery pack is under 5% charge	Remove the battery pack from the tool and charge it
Other problems	Short charges	Not fully charged	Make sure that the battery is fully charged every time by allowing the charger to complete its full charging cycle
		Poor storage condition	Always remove battery from the tool and charger when not in use and store in a dry secure place. Avoid charging or storing your battery in temperatures below 5°C and above 40°C. Cool down a hot battery pack from a tool that has just been operated for approximately 30 minutes before storage



## CARE & MAINTENANCE

### MAINTENANCE

Your tool requires no additional lubrication or maintenance. There are no user serviceable parts in your power tool. Never use water or chemical cleaners to clean your power tool. Wipe clean with a dry cloth. Always store your power tool in a dry place. Keep the motor ventilation slots clean. Keep all working controls free of dust.

### RECYCLING AND DISPOSAL



Waste electrical products should not be disposed of with household waste. Please recycle where facilities exist. Check with your Local Authority or retailer for recycling advice.

For further information visit [www.recycle-more.co.uk](http://www.recycle-more.co.uk)

### DISPOSAL OF AN EXHAUSTED BATTERY PACK



To preserve natural resources, please recycle or dispose of the battery pack properly. This battery pack contains Li-Ion batteries. Consult your local waste authority for information regarding available recycling and/or disposal options. Discharge your battery pack by operating your tool, then remove the battery pack from the tool housing and cover the battery pack connections with heavy-duty adhesive tape to prevent short circuit and energy discharge. Do not attempt to open or remove any of the components.

### REPAIR

This product does not contain any parts that can be repaired by the consumer. Contact an authorised service centre or a similarly qualified person to have it checked and repaired.

### STORAGE

- Switch the product off and remove the battery pack.
- Clean the product as described above.
- Store the product and its accessories in a dark, dry, frost-free, well-ventilated place.
- Always store the product in a place that is inaccessible to children.
- We recommend using the original package for storage or covering the product with a suitable cloth or enclosure to protect it against dust.

### TRANSPORTATION

- Switch the product off and remove the battery pack.
- Attach transportation guards, if applicable.
- Always carry the product by its handle.
- Protect the product from any heavy impact or strong vibrations which may occur during transportation in vehicles.
- Secure the product to prevent it from slipping or falling over.



## GUARANTEE

At **Erbauer** we take special care to select high quality materials and use manufacturing techniques that allow us to create ranges of products incorporating design and durability. That's why we offer a 2 year trade guarantee against manufacturing defects on our **Erbauer** power tool products.

This power tool is guaranteed for 2 years from the date of purchase, if bought in store, delivered or bought online. You may only make a claim under this guarantee upon presentation of your sales receipt or purchase invoice. Please keep your proof of purchase in a safe place.

This guarantee covers product failures and malfunctions provided the **Erbauer** power tool was used for the purpose for which it is intended and subject to installation, cleaning, care and maintenance in accordance with standard practice and with the information contained above and in the user manual. This guarantee does not cover defects and damage caused by or resulting from:

- Normal wear and tear, including accessory wear
- Overload, misuse or neglect
- Repairs attempted by anyone other than an authorised agent
- Cosmetic damage
- Damage caused by foreign objects, substances or accidents
- Accidental damage or modification
- Failure to follow manufacturer's guidelines
- Loss of use of the goods

This guarantee is limited to parts recognised as defective. It does not, in any case, cover ancillary costs (movement, labour) and direct and indirect damage.

If the **Erbauer** power tool is defective during the guarantee period, then we reserve the right, at our discretion, to replace the item with a product of equivalent quality and functionality or to provide a refund.

This guarantee only applies to the country of purchase or delivery and is not transferrable to any other countries. This guarantee is non-transferrable to any other person or product. Relevant local law will apply to this guarantee.

Guarantee related queries should be addressed to a store affiliated with the distributor you purchased the **Erbauer** power tool from.

This guarantee is in addition to and does not affect your statutory rights relating to faulty goods as a consumer.

EN



## DECLARATION OF CONFORMITY



### EU Declaration of Conformity

**We**  
**Kingfisher International Products Limited**  
**3 Sheldon Square**  
**London W2 6PX**  
**United Kingdom**

Declare that the product:  
Erbauer 18V cordless combi drill EC DT18-Li-2  
Serial number 00001-99999

Complies with the essential health and safety requirements of the following directives:

2006/42/EC The Machinery Directive  
References to the following harmonized standard were made:  
EN 60745-1:2009 + A11:2010  
EN 60745-2-1:2010

2014/30/EU Electromagnetic Compatibility directive  
References to the following harmonized standard were made:  
EN55014-1: 2017  
EN55014-2: 2015

(EU) 2015/863 amending 2011/65/EU Restrictions of the Use of Certain Hazardous Substances in  
Electrical and Electronic Equipment

Authorised signatory and technical file holder:

Kingfisher International Products Limited  
3 Sheldon Square  
London W2 6PX  
United Kingdom  
on: 18/06/2018

Lisa Davis  
Group Quality Director

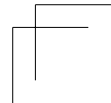
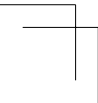
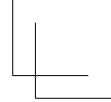
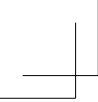



**Manufacturer • Fabricant • Producent • Hersteller • Producator • Fabricante:**

Kingfisher International Products Limited  
3 Sheldon Square London W2 6PX  
United Kingdom  
[www.kingfisher.com/products](http://www.kingfisher.com/products)

**EN DISTRIBUTOR:**

B&Q plc,  
Chandlers Ford, Hants, SO53 3LE  
United Kingdom  
[www.diy.com](http://www.diy.com)

Screwfix Direct Limited,  
Trade House, Mead Avenue,  
Yeovil, BA22 8RT, United Kingdom  
[www.screwfix.com](http://www.screwfix.com)

To view instruction manuals online,  
visit [www.kingfisher.com/products](http://www.kingfisher.com/products)