

Montage- und Betriebsanleitung

EN Installation and operating instructions
ES Instrucciones de montaje y servicio
CS Návod pro montáž a provoz
FR Notice de montage et de mise en service

NL Montage- en bedrijfsinstructies
PL Instrukcja montażu i obsługi
SV Monterings- och driftinstruktion
HU Szerelési és használati útmutató
FI Asennus- ja käyttöohje

EL Συναρμολόγηση και οδηγίες λειτουργίας
IT Istruzioni per il montaggio e l'uso
RO Montaj și instrucțiuni de funcționare
RU Инструкция по монтажу и вводу в эксплуатацию

ANMW500

7612982219634
2030020956
650 × 123 × 550

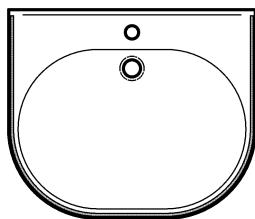

ANMW502

7612982219801
2030020959
550 × 123 × 450

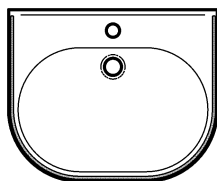

ANMW504

7612982219825
2030020962
450 × 103 × 350

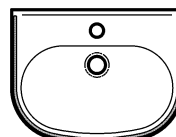

ANMW501

7612982219795
2030020958
650 × 123 × 550

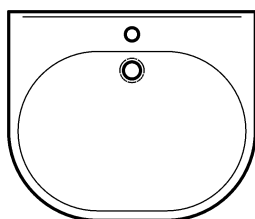

ANMW503

7612982219818
2030020961
550 × 123 × 450

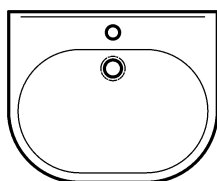

ANMW505

7612982219832
2030020963
450 × 103 × 350

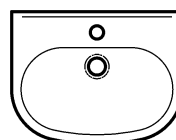

ANMW0017

7612982234378
2030032979
650 × 123 × 550

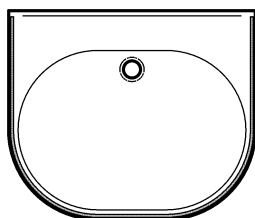

ANMW0016

7612982233449
2030032478
550 × 123 × 450

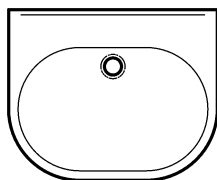

ANMW500

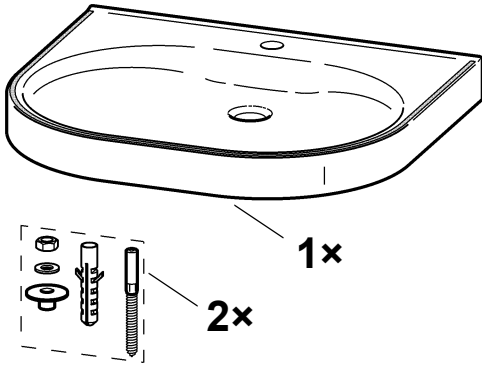

ANMW502

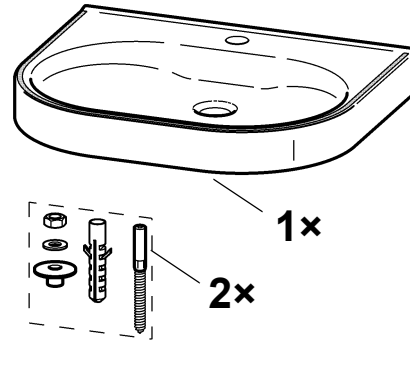

ANMW504

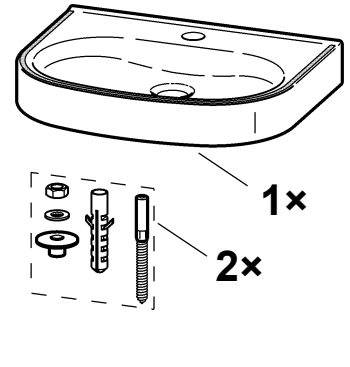

ANMW501

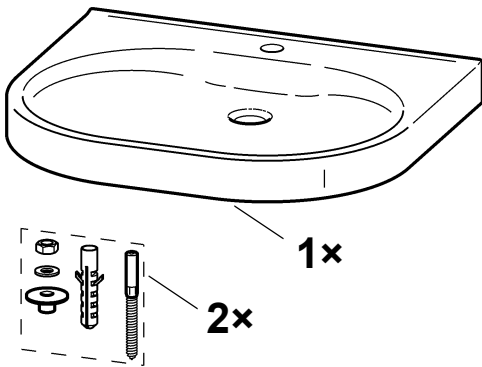

ANMW503

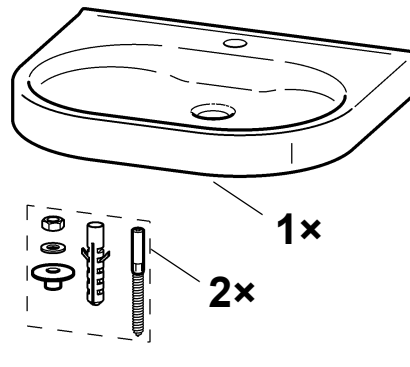

ANMW505

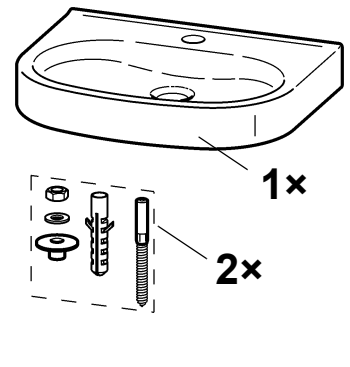

ANMW0017

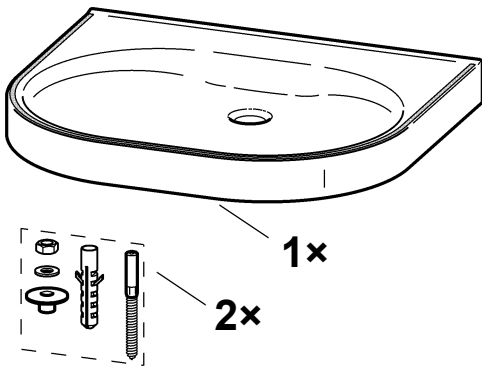

ANMW0016

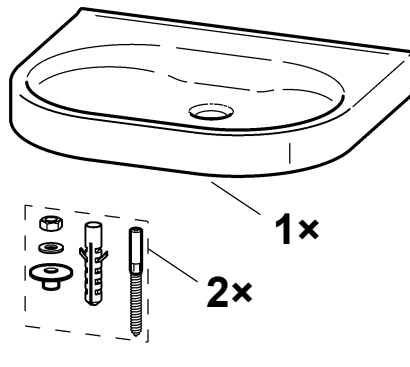

ANMW500

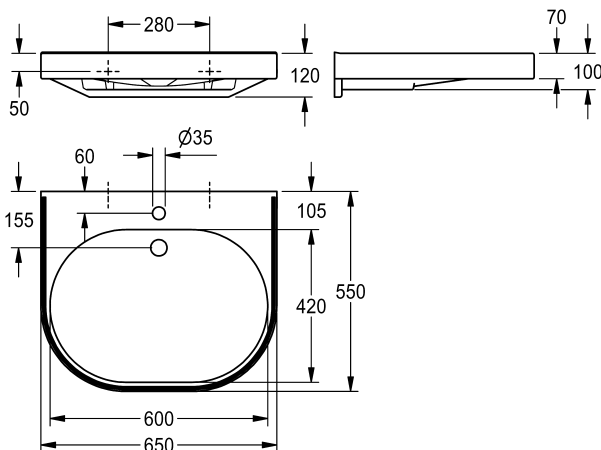

ANMW501

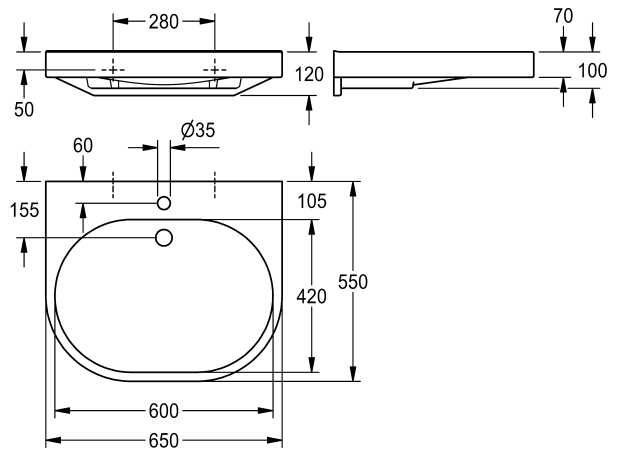

ANMW502

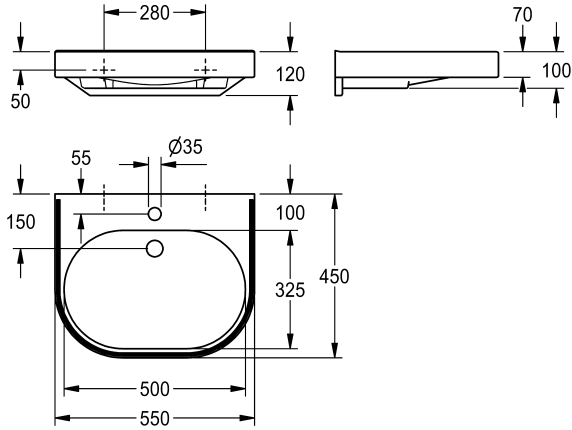

ANMW503

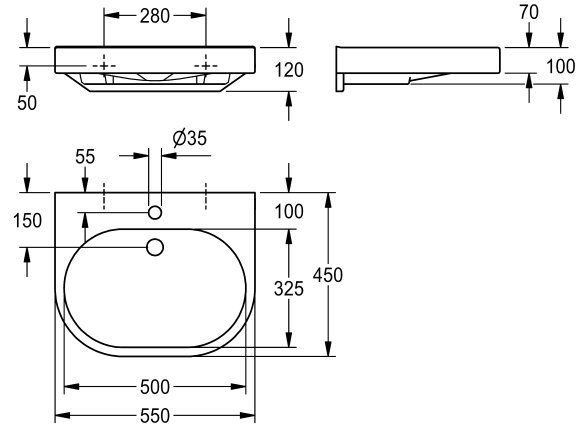

ANMW504

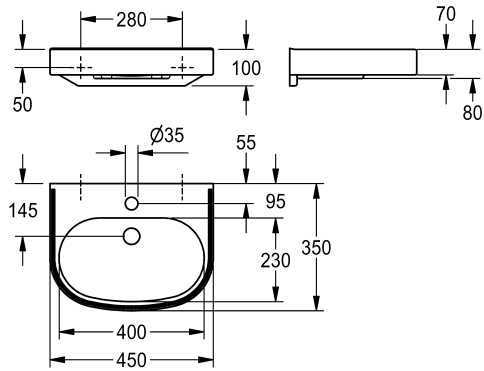

ANMW505

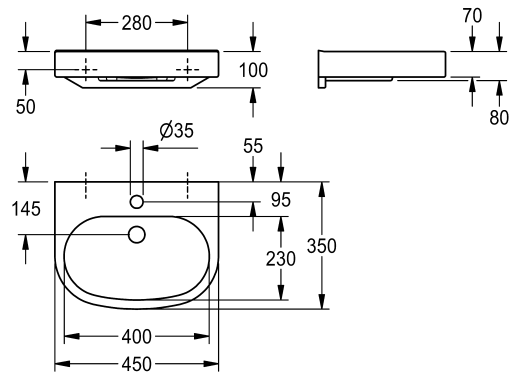

ANMW0017

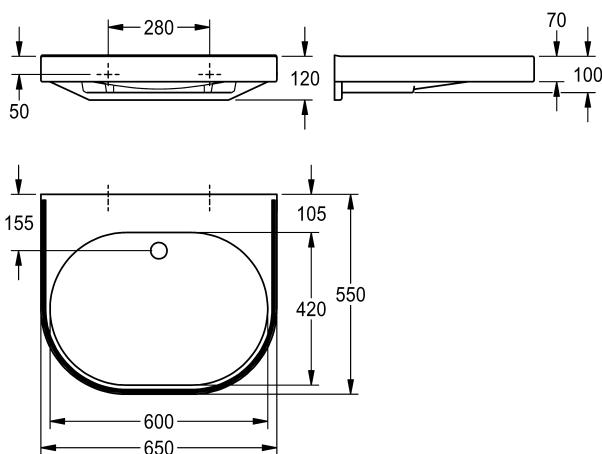

ANMW0016

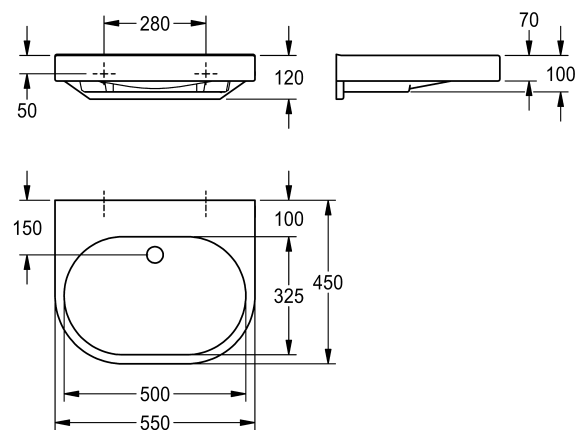

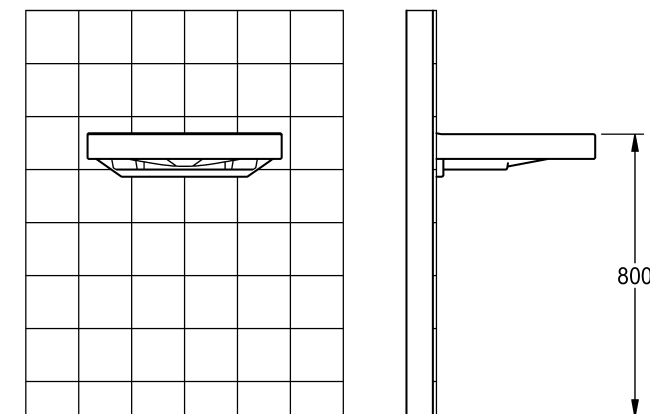

EN Important notes

Do not use abrasive cleaners for cleaning.
When using abrasive cleaners containing acids or alkaline solutions, close attention must be paid to the directions for use.
The cast mineral material can be disposed of as regular domestic waste.

DE Wichtige Hinweise

Zur Reinigung nicht scheuernde Reinigungsmittel verwenden.
Bei Verwendung von säure- oder laugenhaltigen Reinigern sind die Anwendungsvorschriften einzuhalten.
Der Mineralguss kann im normalen Hausmüll entsorgt werden.

NL Belangrijke aanwijzingen

Voor de reiniging geen schurende reinigingsmiddelen gebruiken.
Bij het gebruik van zuur- of looghoudende reinigingsmiddelen moeten de gebruiksvorschriften in acht worden genomen.
Het polymeerbeton kan met het normale huisvuil worden afgevoerd.

SV Viktiga informationer

Använd inte repande rengöringsmedel för rengöring.
Följ bruksanvisningarna vid användning av syra- eller luthaltiga rengöringsmedel.
Mineralmaterialet kan slängas i de vanliga hushållssoporna.

IT Avvertenze importanti

Per la pulizia non utilizzare detergenti abrasivi.
Rispettare le istruzioni per l'uso quando si utilizzano detergenti acidi o basici.
La ghisa minerale può essere smaltita nei normali rifiuti domestici.

FR Remarques importantes

Ne pas utiliser de produit abrasif pour le nettoyage.
Lors de l'utilisation de détergents contenant des acides ou des lessives, respecter les consignes d'utilisation.
La fonte minérale peut être éliminée dans les ordures ménagères.

ES Indicaciones importantes

No utilizar productos de limpieza abrasivos en la limpieza.
Si se utilizan limpiadores que contengan ácidos o lejías se habrán de respetar las Instrucciones de empleo.
La fundición de mineral se puede eliminar junto con la basura doméstica normal.

PL Ważne wskazówki

Do czyszczenia nie stosować środków trących.
Podczas używania środków czyszczących zawierających kwasy lub ług należy przestrzegać przepisów dotyczących ich stosowania.
Odlew mineralny można wyrzucać razem ze zwykłymi odpadami domowymi.

FI Tärkeitä ohjeita

Älä käytä puhdistukseen hankaavia puhdistusaineita.
Mikäli käytät happo- tai emäspitoisia puhdistusaineita, noudata käyttöohjeen määräyksiä.
Keramiikkavalun voit hävittää tavallisena talousjätteenä.

CS Důležité pokyny

Na čištění nepoužívejte abrazivní čisticí prostředky.
Při používání čisticích prostředků s obsahem kyselin nebo louhů dodržujte návody k použití.
Polymerbeton je možné likvidovat jako běžný domácí odpad.

RU Важные указания

Для чистки не используйте абразивные чистящие средства.

При использовании чистящих средств, содержащих кислоты или щелочи, соблюдайте инструкции по применению.

Изделия из минерального литья могут быть утилизированы вместе с обычными бытовыми отходами.

EL Σημαντικές υποδείξεις

Για τον καθαρισμό μη χρησιμοποιείτε καθαριστικά που χαράζουν.

Κατά τη χρήση καθαριστικών που περιέχουν οξέα, ή βάσεις θα πρέπει να τηρούνται οι προδιαγραφές χρήσης.

Το μεταλλικό μέρος μπορεί να απορριφθεί με τα συμβατικά οικιακά απορρίμματα.

HU Fontos utasítások

Ne használjon a tisztításhoz dörzsölő hatású tisztítószert.

Sav- vagy lúgtartalmú tisztítószerek használata esetén vegye figyelembe a használati utasításban leírtakat.

Az ásványi öntvény a normál háztartási hulladékkal együtt kidobható.

RO Indicații importante

Nu folosiți detergenți abrazivi pentru curățire.

În cazul folosirii agenților de curățire cu conținut de acizi și leșii, trebuie respectate directivele de aplicare.

Fonta de minereu poate fi eliminată cu deșeurile casnice normale.

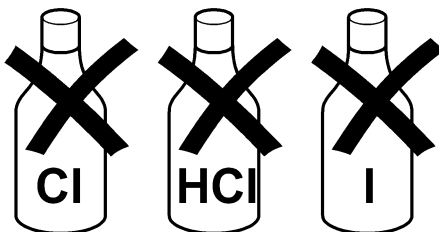
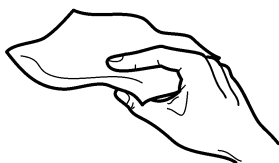

www.franke.com

www.franke.de

Montage

EN Installation
FR Montage
ES Montaje
CS Montáž

NL Montage
PL Montaż
SV Montering
HU Szerelés
FI Asennus

EL Συναρμολόγηση
IT Montaggio
RU Монтаж
RO Montaj

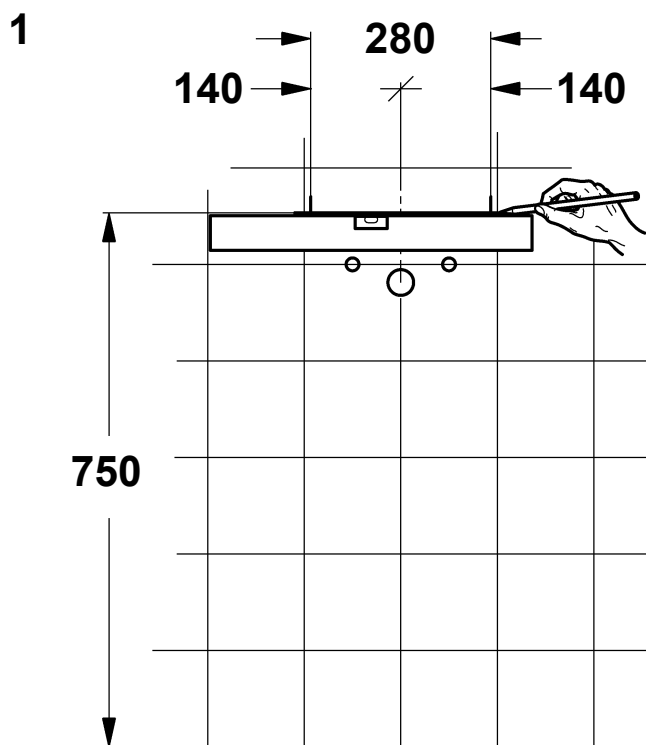

2

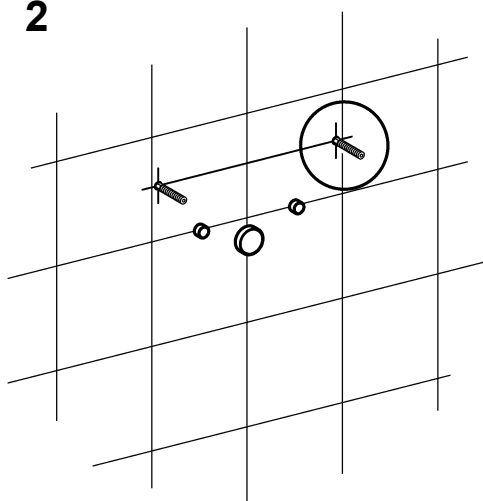

2.1

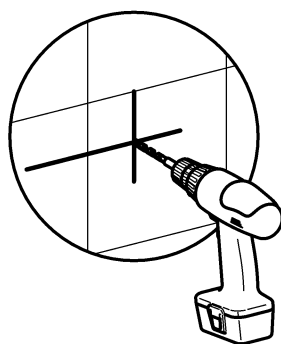

2.2

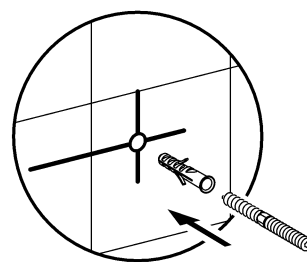

3

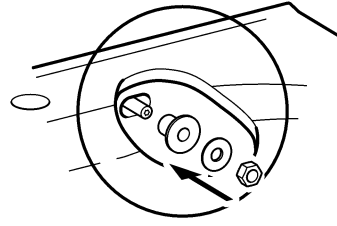
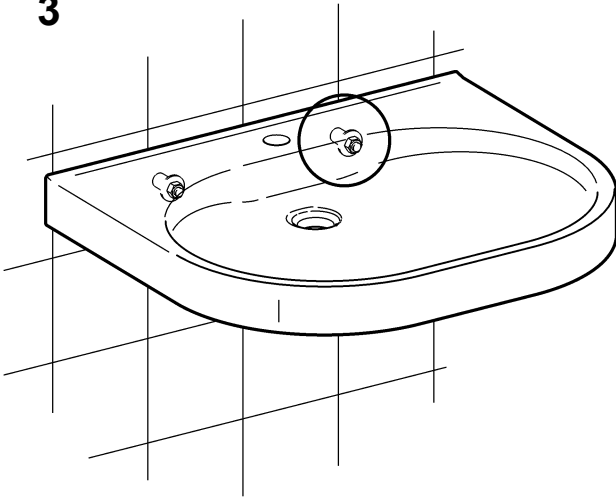

4

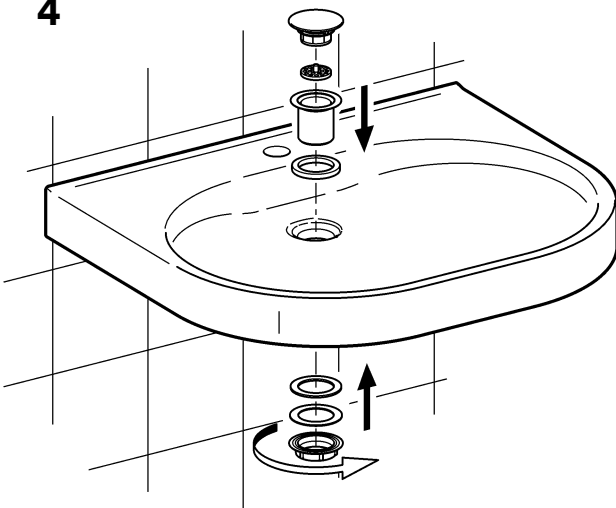

5

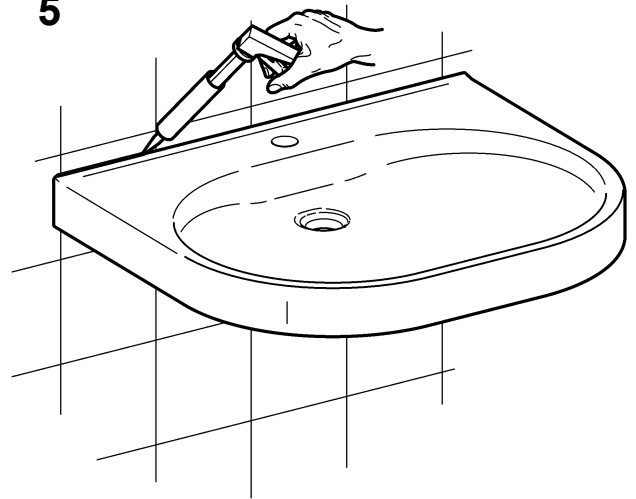

Zubehör

EN Accessories
 FR Accessoire
 ES Accesorios
 CS Příslušenství

NL Toebehoren
 PL Akcesoria
 SV Tillbehör
 HU Alkatrész
 FI Varusteet

EL Αξεσουάρ
 IT Accessori
 RU Принадлежности
 RO Accesorii

2000100861
 ZANMW900

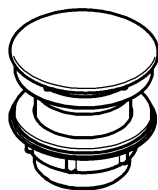

2000100854
 ZANMW901

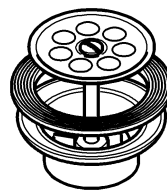

ALG

SARL BFIX
Résidence Chaabani
Val d'Hydra part N°06-C Hydra 08
DZ-16035 HYDRA-ALGER / Algeria
t: +213 (0)21 60 13 60
e: customer@bfixgroupe.com

AUS

PR Kitchen and Washroom Systems Pty Ltd
83 Bangholme Road
Dandenong South VIC 3175
t: +61 (0)3 9700 9100
e: info@prks.com.au

AUT

Franke GmbH
Oberer Achdamm 52
6971 Hard / Austria
t: +43 (0)5574 6735 0
e: ws-info.at@franke.com

BEL

Franke N.V.
Ring 10
9400 Ninove / Belgium
t: +32 (0)54 310130
e: ws-info.be@franke.com

CAN

Franke Kindred Canada Limited
1000 Franke Kindred Road
Midland, Ontario L4R 4K9 / Canada
t: +1 855 446 5663
e: ws-info.ca@franke.com

CZE

Franke Aquarotter GmbH
Parkstrasse 1 - 5
14974 Ludwigsfelde / Germany
t: +420 281 090 429
e: ws-info.cz@franke.com

EGY

Franke Kitchen Systems Egypt S.A.E.
1st Industrial Zone
6th October City, Cairo / Egypt
t: +202 3828 0000
e: ws-info.eg@franke.com

FIN / SWE / NOR / DEN / EST

Franke Finland Oy
Vartiokujja 1
76850 Naarajaervi / Finland
t: +358 (0)15 3411 1
e: ws-info.fi@franke.com

FRA

Franke GmbH
Oberer Achdamm 52
6971 Hard / Autriche
t: 0800 909 216
e: ws-info.fr@franke.com

GBR / IRL

Franke Sissons Ltd.
Carrwood Road
Chesterfield S41 9QB / United Kingdom
t: +44 (0)1246 450 255
e: ws-info.uk@franke.com

GBR

Dart Valley Systems Ltd.
Kemings Close, Long Road,
Paignton TQ4 7TW / United Kingdom
t: +44 (0)1803 529 021
e: sales@dartvalley.co.uk

GER

Franke Aquarotter GmbH
Parkstrasse 1 - 5
14974 Ludwigsfelde / Germany
t: +49 (0)3378 818 0
e: ws-info.de@franke.com

GEO

Franke Caucasus Ltd.
7, Agladze Street
Tbilisi, 0154 / Georgia
t: +995 (0)32 2351672
e: info@franke-ge.com

ITA

Franke GmbH
Oberer Achdamm 52
6971 Hard / Austria
t: 800 789233
e: ws-info.it@franke.com

NED

Franke N.V.
Ring 10
9400 Ninove / Belgium
t: +31 (0)492 72 82 24
e: ws-info.nl@franke.com

POL

Franke Aquarotter GmbH
Parkstrasse 1-5
14974 Ludwigsfelde / Germany
t: +48 (0) 22 711 61 17
e: ws-info.pl@franke.com

POR

Franke Portugal S.A.
Estrada de Talaide, Edifício 3, Cruzamento
de Sao Marcos, 2735-531 Cacém / Portugal
t: +351 (0)21 426 9670
e: ws-info.pt@franke.com

RSA

Franke Kitchen Systems (Pty) Ltd.
1194 South Coast Road
4060 Moberni / South Africa ZAF
t: +27 (0)31 450 6300
e: ws-info.za@franke.com

RUS

Franke Neva GmbH
Volgogradsky prospect, 43 building 3
109316 Moscow / Russia
t: +7 495 225 56 58
e: fs-info.ru@franke.com

SLO

Barjans d.o.o.
Pod Hruševco 20
1360 Vrhnika / Slovenia
t: +386 (0)1 750 66 40
e: info@barjans.si

SUI

Franke Washroom Systems AG
Franke-Strasse 9, Postfach 237
4663 Aarburg / Switzerland
t: +41 (0)62 787 3131
e: ws-info.ch@franke.com

SVK

INGEMA s.r.o.
Močarianska 1
071 01 Michalovce / Slovakia
t: +421 (0)56 640 36 12
e: ingema@ingema.sk

TUN

HANDASSA GROUP
48 Av. Taieb Mhiri Imm. Les Jasmins apt. n°5.
2080 Ariana / Tunisia
t: +216 (0)71 702 272
e: info@handassagroup.com.tn

TUR

Franke Mutfak ve Banyo Sistemleri San. ve
Tic. A.S
Gebze Organize Sanayi Bölgesi
Tembelova Alanı 3500 sokak No: 3503
Gebze, Kocaeli / Türkiye
t: +90 (0)262 644 6595
e: ws-info.tr@franke.com

UAE

Franke L.L.C
P.O. Box 14511
Ras Al Khaimah / United Arab Emirates
t: +971 (0)7 2034 700
e: franke-customerservice.ae@franke.com

USA

Franke Kindred Canada Limited
1000 Franke Kindred Road
Midland, Ontario L4R 4K9 / Canada
t: +1 855 526 0503
e: commercial-info.us@franke.com

**Other East-European Countries
(HU/RO/BG/CRO/SRB/BIH/UKR)**

Franke Aquarotter GmbH
Parkstrasse 1 - 5
14974 Ludwigsfelde / Germany
t: +49 (0)3378 818 0
e: ws-info.de@franke.com

Other Countries:

Franke GmbH
Oberer Achdamm 52
6971 Hard / Austria
t: +43 (0)5574 6735 0
e: ws-info.int@franke.com