

ENLITE

EN-LPEM2 EMERGENCY PACK

PLEASE READ THESE INSTRUCTIONS CAREFULLY BEFORE INSTALLATION
LEAVE A COPY FOR THE USER / MAINTENANCE ENGINEER FOR FUTURE REFERENCE

Product Specification:

-Mains Voltage:	230VAC +/- 10%
-Mains Frequency:	50-60Hz
-Power Consumption (excluding external driver):	4VA
-Emergency output voltage range:	(See product label)
-Emergency Duration:	(See product label)
-Battery:	(See product label)
-Allowed ambient temp:	+5°C to +35°C
-Min/Max conductor sizes:	0.5 - 1.5mm ²
-Weight:	0.6kg
-Charging time:	24 hours
-Protection class:	1
-Degree of protection:	IP20
-Em module complies with:	IEC 61347-2-7
-Suitable for installation to:	EN50172 and BS7671

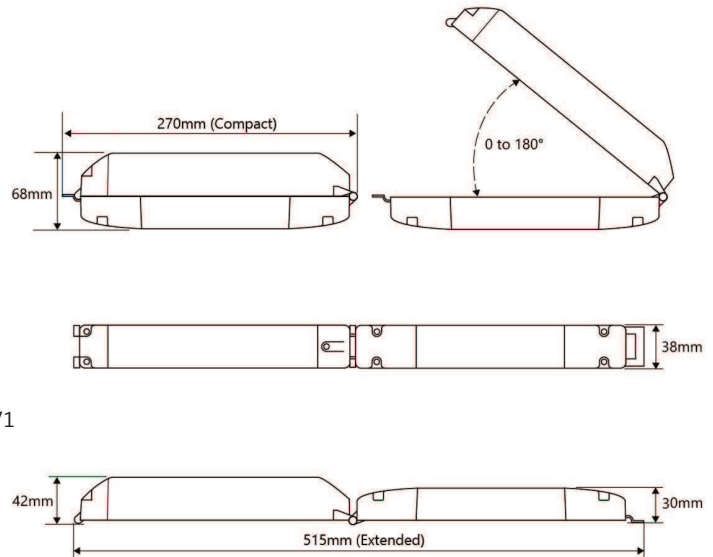

The unit provides reinforced insulation between the mains supply and battery charging circuit and employs self-resetting protection against short-circuit of battery terminals. Normal charging will resume automatically once a fault is removed.

Installation:

NOTE - To comply with regulations, installation must be carried out by suitably qualified competent person and in accordance with the current IEE wiring regulations (BS7671) and building regulations. The emergency pack requires 2 live feeds, a permanent supply for charging the battery pack and 1 for switching of the product.

Ensure the mains supply is isolated before attempting installation!

Please refer to page 2 of this leaflet for details of mains supply, driver and product connections.

Once wiring is complete, use the plastic end covers and screws provided to secure cables in place and to prevent unauthorised access.

If external plug and socket connectors are used without means to prevent accidental disconnection, the remote box should be sited so that it is protected from unauthorised disconnection.

A recessed mount can be found inside the packaging carton to assist installation of the LED indicator so it is visible during normal use.

Once installed, the indicator LED will be illuminated and the supply should be left undisturbed for a minimum of 24 hours to charge the batteries before attempting a commissioning test. After a successful test, the date should be noted on the space provided on the battery. A service record is also provided on page 2 of this document.

Standard / single colour (green) shows the following condition:

A green LED shows the following conditions:

- LED off: mains failure [below 160V] or battery fully discharged or faulty unit.
- LED green: mains OK and battery connected.

Emergency Lighting 'standard' or 'manual' Test

The following minimum inspections and tests should be carried out:

Monthly

Switch off the mains power supply to the lighting unit. Inspect all emergency lights for satisfactory operation. Any defects should be noted and actioned by a competent person as soon as possible.

Yearly

Switch off the mains power supply to the lighting unit. Leave the unit to run for the rated period (e.g. three hours). The lights should remain operable from the battery for the whole period.

Please be aware that further inspection / testing may be required, e.g. by risk assessment / local legislation.

Batteries and Disposal

The battery has a designed service life of 4 years and must be replaced in a timely manner to ensure the integrity of the emergency lighting system is maintained. In any case, the battery should be replaced when it no longer provides the rated duration (i.e 3 hours).

The manufacturer of the emergency pack is committed to fulfil its obligations as a producer of batteries used in emergency lighting applications. End-of-life batteries may either be returned to the emergency pack manufacturer at the customers cost and arrangements will be made to ensure their correct disposal. Alternatively it may be more convenient for the customer to deliver end-of-life batteries to site(s) of authorised treatment facilities at their cost and it will be ensured that they are accepted back and subsequently treated to the standard required by the regulations.

Enlite

Tel: 01727 836611 Fax: 01727 836622
Website: www.enlite.eu Email: sales@enlite.eu
Document version – EN-LPEM2_V2_17

External Wiring connections with jack plug connectors

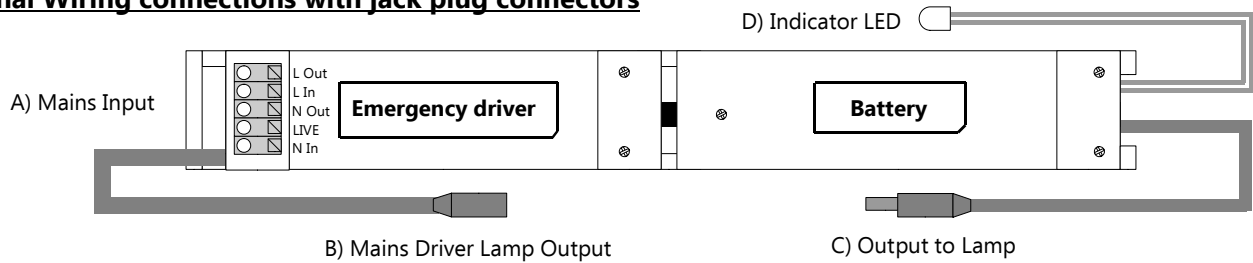

- A) Mains Supply Input –** Emergency driver terminal mains input is as follows -
 Control switched live OUT to mains driver live in
 Control switched live IN from mains supply
 Neutral OUT to mains driver neutral in
 Un-switched live IN from mains supply
 Neutral IN from mains supply
- B) Mains Driver lamp output –** Connect jack plug to mains driver lamp output
- C) Output to Lamp –** Connect jack plug to LED lamp
- D) Indicator LED –** Please see installation section of instructions (Page 1)

Note: Jack plug connectors appearance may change however connections will always be as follows:
 Mains driver lamp output from emergency driver side of enclosure.
 Output to lamp from battery side of enclosure.

Emergency Installation and Inspection

Installation / Test Record	Serial / Luminaire Number:			
	Installed By:		Date:	
	Commissioned By:		Date:	

	Year 1		Year 2		Year 3		Year 4*	
	Signed	Date	Signed	Date	Signed	Date	Signed	Date
Monthly test								
1								
2								
3								
4								
5								
6								
7								
8								
9								
10								
11								
12								

Environmental Protection (W.E.E.E.) – Enlite’s WEEE Reg.No. WEE/BG0130YX (UK Only)



Waste Electrical & Electronic Equipment Regulations (WEEE) requires that any of our products showing this marking (left) must not be disposed of with other household or commercial waste. Enlite does not levy any WEEE disposal charges to its customers for affected WEEE related products. To prevent possible harm to the environment or human health from uncontrolled waste disposal, please separate any such product from other waste types and recycle it responsibly at your local facilities. Check with your Local Authority, Recycling Centre or retailer for recycling advice. If, when you purchased any Enlite product, your supplier included a WEEE disposal fee, you should then contact your supplier for advice on his take back of the product for the correct disposal.

WARRANTY

This product is guaranteed for a period of 1 years from the date of purchase. The guarantee is invalid in the case of improper use, installation, tampering, and removal of the Q.C. date label, installation in an improper working environment or installation not according to the current edition of the National Wiring Regulations. Should this product fail during the guarantee period it will be replaced free of charge, subject to correct installation and return of the faulty unit. Enlite does not accept responsibility for any installation costs associated with the replacement of this product. This warranty is in addition to the statutory rights in your country of purchase. Enlite reserves the right to alter specifications without prior notice.