

Milwaukee®

Nothing but **HEAVY DUTY**®



M18 ONE SLSP

Original instructions

Originalbetriebsanleitung

Notice originale

Istruzioni originali

Manual original

Oorspronkelijke gebruiksaanwijzing

Original brugsanvisning

Original bruksanvisning

Bruksanvisning i original

Alkuperäiset ohjeet

Πρωτότυπο οδηγιών χρήσης

Orijinal işletme talimatı

Původním návodem k používání

Pôvodný návod na použitie

Instrukcja oryginalną

Eredeti használati utasítás

Izvirna navodila

Originalne pogonske upute

Instrukcijām oriģinālvalodā

Originalni instrukcija

Algupärane kasutusjuhend

Оригинальное руководство по эксплуатации

Оригинално ръководство за експлоатация

Instrucțiuni de folosire originale

Оригинален прирачник за работа

Оригінал інструкції з експлуатації

التعليمات الأصلية

ENGLISH		Picture section with operating description and functional description	4
DEUTSCH		Bildteil mit Anwendungs- und Funktionsbeschreibungen	4
FRANÇAIS		Partie imagée avec description des applications et des fonctions	4
ITALIANO		Sezione illustrata con descrizione dell'applicazione e delle funzioni	4
ESPAÑOL		Sección de ilustraciones con descripción de aplicación y descripción funcional	4
PORTUGUES		Parte com imagens explicativas contendo descrição operacional e funcional	4
NEDERLANDS		Beelddedeelte met toepassings- en functiebeschrijvingen	4
DANSK		Billedel med anvendelses- og funktionsbeskrivelser	4
NORSK		Billedel med bruks- og funksjonsbeskrivelse	4
SVENSKA		Bilddel med användnings- och funktionsbeskrivning	4
SUOMI		Kuvasivut käyttö- ja toimintakuvaukset	4
ΕΛΛΗΝΙΚΑ		Τμήμα εικόνων με περιγραφές χρήσης και λειτουργίας	4
TÜRKÇE		Resim bölümü Uygulama ve fonksiyon açıklamaları ile birlikte	4
ČESKY		Obrazová část s popisem aplikací a funkcí	4
SLOVENSKY		Obrazová část s popisom aplikácií a funkcií	4
POLSKI		Część rysunkowa z opisami zastosowania i działania	4
MAGYAR		Képes részalkalmazási- és működési leírásokkal	4
SLOVENSKO		Del slike z opisom uporabe in funkcij	4
HRVATSKI		Dio sa slikama opisima primjene i funkcija	4
LATVISKI		Attēla daļa ar lietošanas un funkciju aprakstiem	4
LIETUVIŠKAI		Paveikslėlio dalis su vartojimo instrukcija ir funkcijų aprašymais	4
EESTI		Pildiosa kasutusjuhendi ja funktsioonide kirjeldusega	4
РУССКИЙ		Раздел иллюстраций с описанием эксплуатации и функций	4
БЪЛГАРСКИ		Част със снимки с описание за приложение и функции	4
ROMÂNIA		Secvența de imagine cu descrierea utilizării și a funcționării	4
МАКЕДОНСКИ		Дел со сликисо описи за употреба и функционирање	4
УКРАЇНСЬКА		Частина з зображеннями з описом робіт та функцій	4
عربي		قسم الصور يوجد به الوصف التشغيلي والوظيفي	4

Text section with Technical Data, important Safety and Working Hints and description of Symbols	14
Textteil mit Technischen Daten, wichtigen Sicherheits- und Arbeitshinweisen und Erklärung der Symbole.	16
Partie textuelle avec les données techniques, les consignes importantes de sécurité et de travail ainsi que l'explication des pictogrammes.	18
Sezione testo con dati tecnici, importanti informazioni sulla sicurezza e sull'utilizzo, spiegazione dei simboli.	20
Sección de texto con datos técnicos, indicaciones importantes de seguridad y trabajo y explicación de los símbolos.	22
Parte com texto explicativo contendo Especificações técnicas, Avisos de segurança e de operação e a Descrição dos símbolos.	24
Tekstgedeelte met technische gegevens, belangrijke veiligheids- en arbeidsinstructies en verklaring van de symbolen.	26
Tekstdel med tekniske data, vigtige sikkerheds- og arbejdsanvisninger og symbolforklaring.	28
Tekstdel med tekniske data, viktige sikkerhets- og arbeidsinstruksjoner og forklaring av symbolene.	30
Tekstdel med tekniska informationer, viktiga säkerhets- och användningsinstruktioner samt symbolförklaringar.	32
Tekstisivut: tekniset tiedot, tärkeät turvallisuus- ja työskentelyohjeet sekä merkien selitykset.	34
Τμήμα κειμένου με τεχνικά χαρακτηριστικά, σημαντικές υποδείξεις ασφαλείας και εργασίας και εξήγηση των συμβόλων.	36
Teknik bilgileri, önemli güvenlik ve çalışma açıklamalarını ve de sembollerin açıklamalarını içeren metin bölümü.	38
Textová část s technickými daty, důležitými bezpečnostními a pracovními pokyny a s vysvětlivkami symbolů	40
Textová část s technickými datami, důležitými bezpečnostními a pracovními pokyny a s vysvětlivkami symbolov	42
Część opisowa z danymi technicznymi, ważnymi wskazówkami dotyczącymi bezpieczeństwa i pracy oraz objaśnieniami symboli.	44
Szöveges rész műszaki adatokkal, fontos biztonsági- és munkavégzési útmutatásokkal, valamint a szimbólumok magyarázata.	46
Del besedila s tehničnimi podatki, pomembnimi varnostnimi opozorili in delovnimi navodili in pojasnili simbolov.	48
Dio štiva sa tehničkim podacima, važnim sigurnosnim i radnim uputama i objašnjenjem simbola.	50
Teksta daļa ar tehnikajiem parametriem, svarīgiem drošības un darbības norādījumiem, simbolu atšifrējumiem.	52
Teksto dalis su techniniais duomenimis, svarbiomis saugumo ir darbo instrukcijomis bei simbolių paaiškinimais.	54
Tekstiosa tehniliste näitajate, oluliste ohutus- ja tööjuhenditega ning sümbolite kirjeldustega.	56
Текстовый раздел, включающий технические данные, важные рекомендации по безопасности и эксплуатации, а также описание используемых символов.	58
Част с текст с технически данни, важни указания за безопасност и работа и разяснение на символите.	60
Porțiune de text cu date tehnice, indicații importante privind siguranța și modul de lucru și descrierea simbolurilor.	62
Tekstualen del со Технички карактеристики, важни безбедносни и работни упатства и објаснување на симболите.	64
Текстова частина з техничними даними, важливими вказівками з техніки безпеки та експлуатації і поясненням символів.	66
القسم النصي المزود بالبيانات الفنية والنصائح الهامة للسلامة والعمل ووصف الرموز	71

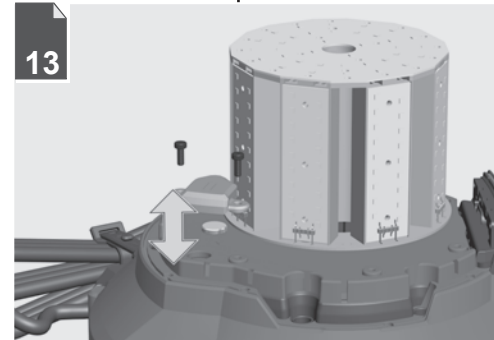
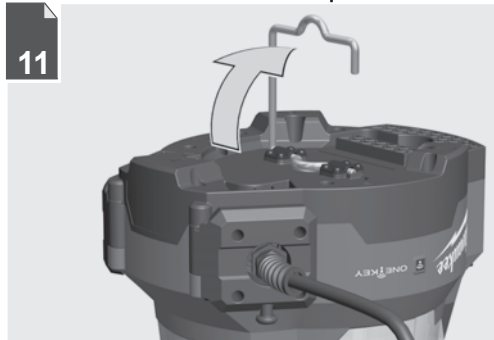



1



2



1



2



Remove the battery pack before starting any work on the machine.

Vor allen Arbeiten an der Maschine den Wechselakku herausnehmen

Avant tous travaux sur la machine retirez l'accu interchangeable.

Prima di iniziare togliere la batteria dalla macchina.

Retire la batería antes de comenzar cualquier trabajo en la máquina.

Antes de efectuar cualquier intervención na máquina retirar o bloco acumulador.

Voor alle werkzaamheden aan de machine de akku verwijderen.

Ved arbejde inden i maskinen, bør batteriet tages ud.

Ta ut vekselbatteriet før du arbeider på maskinen

Drag ur batteripaket innan arbetet utföres på maskinen.

Tarkista pistotulppa ja verkkojohto mahdollisilta vaurioilta. Viat saa korjata vain alan erikoisiesimies.

Πριν από κάθε εργασία στη μηχανή αφαιρέστε την ανταλλακτική μπαταρία.

Aletin kendeinde bir çalışma yapmadan önce kartuş aküyü çıkarın.

Před zahájením veškerých prací na vrtacím šroubovákú vyjmout výměnný akumulátor.

Pred každou prácou na stroji výmenný akumulátor vytiahnuť.

Przed przystąpieniem do jakichkolwiek prac na elektronarzędziu należy wyjąć wkładkę akumulatorową.

Karbantartás, javítás, tisztítás, stb. előtt az akkumulátort ki kell venni a készülékből.

Pred deli na stroju izvlécite izmenljivi akumulator.

Prije svih radova na stroju izvaditi bateriju za zamjenu.

Pirms mašīnai veikt jebkāda veida apkopes darbus, ir jāizņem ārā akumulators.

Prieš atlikdami bet kokius darbus įrenginyje, išimkite keičiamą akumuliatorių.

Enne kõiki töid masina kallal võtke vahetatav aku välja.

Виньте аккумулятор из машины перед проведением с ней каких-либо манипуляций.

Преди започване на каквито е да е работи по машината извадете акумулатора.

Scoteți țij acumulatorul înainte de a începe orice intervenție pe mașină.

Отстранете ја батеријата пред да започнете да ја користите машината.

Перед будь-якими роботами на машині віняти змінну акумуляторну батарею.

قم بإزالة حزمة البطارية قبل البدء في أي أعمال على الجهاز.

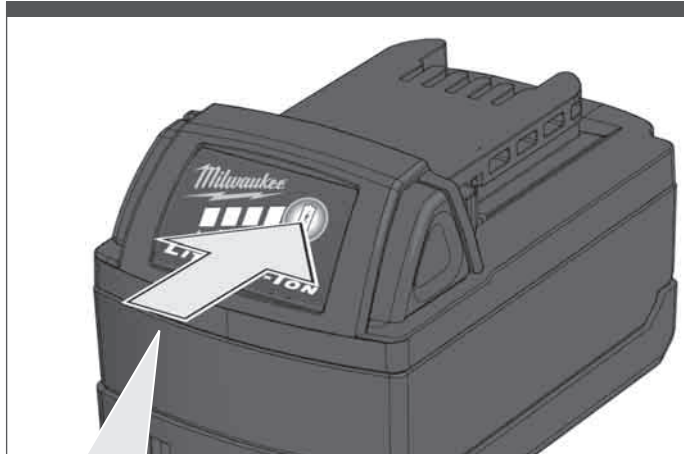

	78-100 %
	55-77 %
	33-54 %
	10-32 %
	< 10 %

➔



ON



OFF

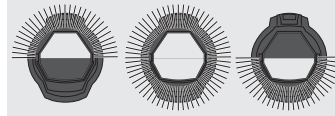

1.

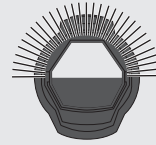

2.

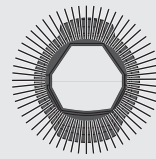

3.

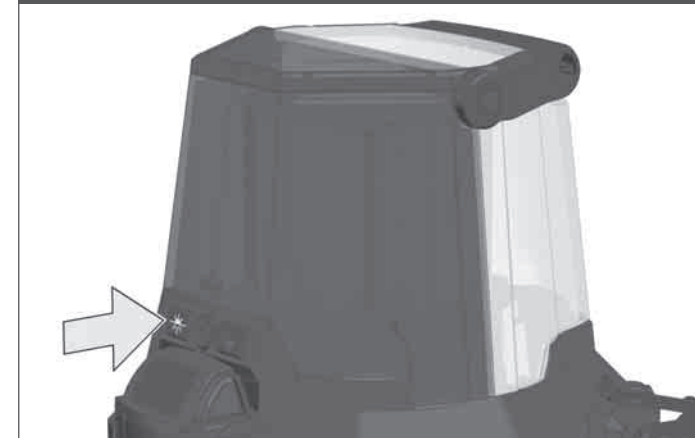
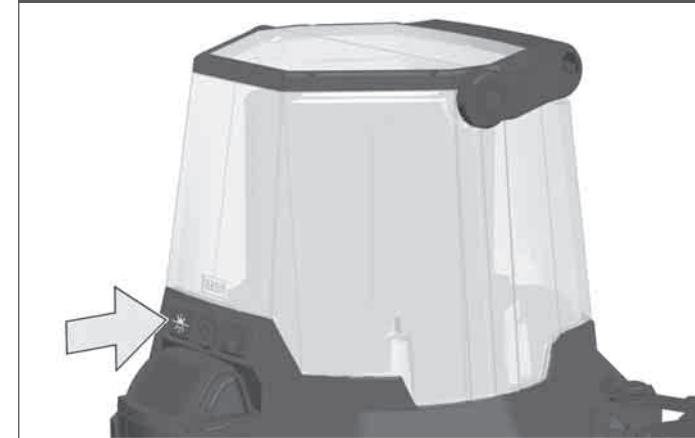
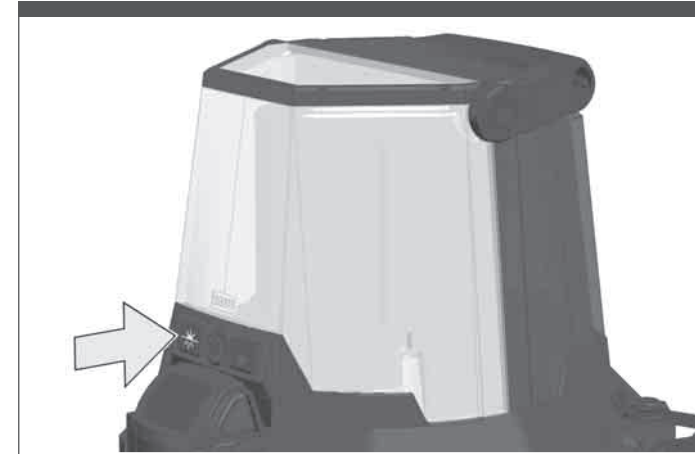
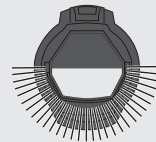



1.



2.



3.

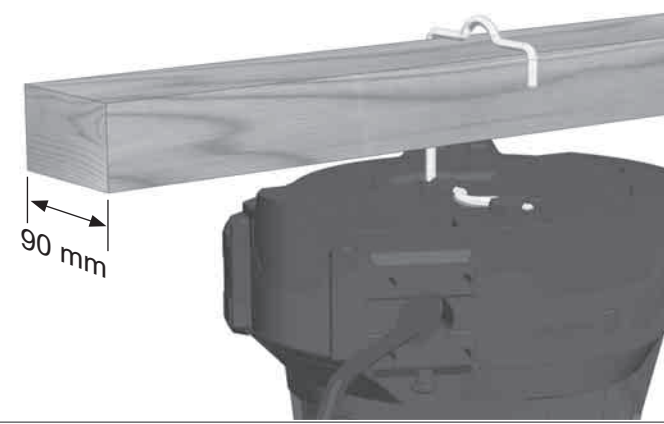
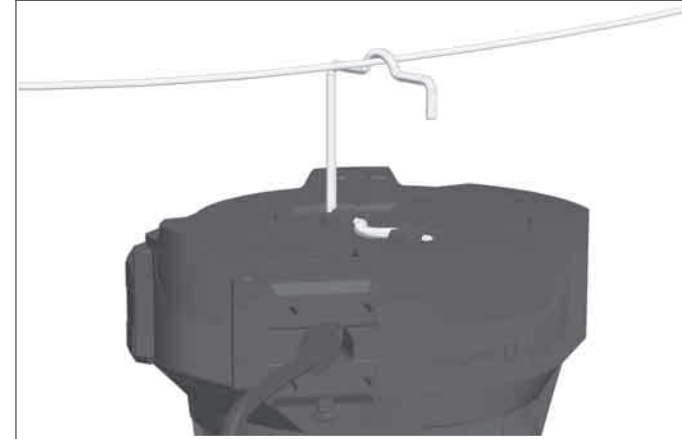
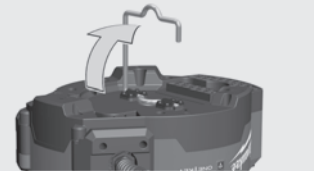
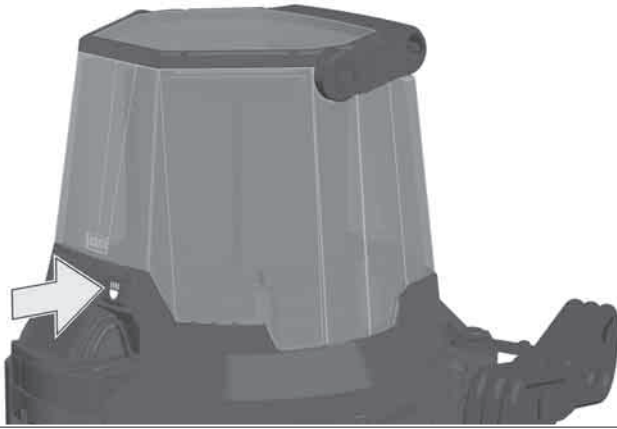

TECHNICAL DATA BATTERY-LAMP

M18 ONESLSP

Lighting time with one fully charged battery (5.0 Ah)	
Mode 3 High Level.....	2 h
Mode 2 Med Level.....	4 h
Mode 1 Low Level.....	8 h
Luminous flux	
High Level.....	4400 lm
Med Level.....	2100 lm
Low Level.....	1000 lm
Colour rendering index (CRI).....	70
Colour temperature.....	4000 K
AC Mode	
Voltage.....	110-240 V
Rated Output Voltage.....	EU/DK/F: 230 V, UK: 110 V
Rated Output Current.....	EU/DK/F: 16 A, UK: 13 A
Rated Power Input.....	50 W
DC Mode	
Rated Power Input.....	40 W
Battery voltage.....	18 V
Frequency band(s) of Bluetooth.....	2.402-2.48 GHz
Maximum radio-frequency power transmitted in the frequency band(s).....	1.8 dBm
Bluetooth version.....	4.0BT signal mode
Weight without battery.....	6,0 kg
Weight according EPTA-Procedure 01/2003 (2.0 Ah).....	6,4 kg
Weight according EPTA-Procedure 01/2003 (5.0 Ah).....	6,7 kg
Weight according EPTA-Procedure 01/2003 (9.0 Ah).....	7,1 kg
Protection class.....	IP40/IP54

⚠ WARNING Read all safety warnings and all instructions. Failure to follow the warnings and instructions may result in electric shock, fire and/or serious injury. **Save all warnings and instructions for future reference.**

SAFETY INSTRUCTIONS

Remove the battery pack before starting any work on the appliance.

Do not dispose of used battery packs in the household refuse or by burning them. Milwaukee Distributors offer to retrieve old batteries to protect our environment.

Do not store the battery pack together with metal objects (short circuit risk).

Use only compatible Milwaukee chargers from the same battery platform for charging battery packs. Do not use battery packs from other systems.

Battery acid may leak from damaged batteries under extreme load or extreme temperatures. In case of contact with battery acid wash it off immediately with soap and water. In case of eye contact rinse thoroughly for at least 10 minutes and immediately seek medical attention.

Warning: Do not direct the light beam at persons or animals and do not stare into the light beam yourself (not even from a distance). Staring into the light beam may result in serious injury or vision loss.

The light source contained in this luminaire shall only be replaced by the manufacturer or his service agent or a similar qualified person.

If the supply cord of this appliance is damaged, it must only be replaced by a repair shop appointed by the manufacturer, because special purpose tools are required

SPECIFIED CONDITIONS OF USE

The Battery-lamp is intended to be used light independent use away from mains supply.

Do not use this product in any other way as stated for normal use.

EC-DECLARATION OF CONFORMITY

Hereby, Techtronic Industries GmbH declares that the radio equipment type M18 ONESLSP is in compliance with Directive 2014/53/EU. The full text of the EU declaration of conformity is available at the following internet address: <http://services.milwaukeeool.com>

ONE-KEY™

To learn more about the ONE-KEY functionality for this tool, please reference the Quick Start guide included with this product or go to www.milwaukeeool.com/one-key. To download the ONE-KEY app, visit the App Store or Google Play from your smart device.

We considered the results to be within our minimum acceptable performance level according to EN 55014-2 / EN 301489-1 / EN 30149-17.

BATTERIES

Battery packs which have not been used for some time should be recharged before use.

Temperatures in excess of 50°C (122°F) reduce the performance of the battery pack. Avoid extended exposure to heat or sunshine (risk of overheating).

The contacts of chargers and battery packs must be kept clean.

For an optimum life-time, the battery packs have to be fully charged, after use.

To obtain the longest possible battery life remove the battery pack from the charger once it is fully charged.

For battery pack storage longer than 30 days: Store the battery pack where the temperature is below 27°C and away from moisture

Store the battery packs in a 30% - 50% charged condition Every six months of storage, charge the pack as normal.

TRANSPORTING LITHIUM BATTERIES

Lithium-ion batteries are subject to the Dangerous Goods Legislation requirements.

Transportation of those batteries has to be done in accordance with local, national and international provisions and regulations.

- The user can transport the batteries by road without further requirements.
- Commercial transport of Lithium-Ion batteries by third parties is subject to Dangerous Goods regulations. Transport preparation and transport are exclusively to be carried out by appropriately trained persons and the process has to be accompanied by corresponding experts.

When transporting batteries:

- Ensure that battery contact terminals are protected and insulated to prevent short circuit.
- Ensure that battery pack is secured against movement within packaging.
- Do not transport batteries that are cracked or leak.

Check with forwarding company for further advice

AC OPERATION

Several lamps can be connected together in AC mode. Please observe the following limits.

230 V			
Fuse	maximum number of lamps	cable length/lamp	cable length total
10 A	16	2,5 m	40 m
16 A	24	2,5 m	60

110 V			
Fuse	maximum number of lamps	cable length/lamp	cable length total
10 A	8	2,5 m	20 m
16 A	12	2,5 m	30 m

MAINTENANCE

For type Y attachments:
If the external flexible cable or cord of this luminaire is damaged, it shall be exclusively replaced by the manufacturer or his service agent or similar qualified person in order to avoid a hazard.



Caution! Risk of electric shock.

The light source contained in this luminaire shall only be replaced by the manufacturer or his service agent or a similar qualified person.

Use only Milwaukee accessories and spare parts. Should components need to be replaced which have not been described, please contact one of our Milwaukee service agents (see our list of guarantee/service addresses).

If needed, an exploded view of the tool can be ordered. Please state the machine type printed as well as the six-digit No. on the label and order the drawing at your local service agents or directly at: Techtronic Industries GmbH, Max-Eyth-Straße 10, 71364 Winnenden, Germany.

SYMBOLS



CAUTION! WARNING! DANGER!



Please read the instructions carefully before starting the machine.



Always disconnect the plug from the socket before carrying out any work on the machine.



Remove the battery pack before starting any work on the machine.



Do not stare at the operating light source.



Class II tool. Tool in which protection against electric shock does not rely on basic insulation only, but in which additional safety precautions, such as double insulation or reinforced insulation, are provided. There being no provision for protective earthing or reliance upon installation conditions.



IP40 EU (production code 4000 4586 92)
France (production code 4000 4588 60)
Door opened status -> protection class IP40



IP54 EU (production code 4000 4586 92)
France (production code 4000 4588 60)
Door closed status -> protection class IP54



UK (production code 4000 4588 55)
Protection class IP54



Denmark (production code 4000 4588 65)
AC mode -> protection class IP40



Denmark (production code 4000 4588 65)
DC mode -> protection class IP54



Do not dispose electric tools, batteries/rechargeable batteries together with household waste material. Electric tools and batteries that have reached the end of their life must be collected separately and returned to an environmentally compatible recycling facility. Check with your local authority or retailer for recycling advice and collection point.



European Conformity Mark



National mark of conformity Ukraine



EurAsian Conformity Mark.

Copyright 2017
Techtronic Industries GmbH
Max-Eyth-Straße 10
71364 Winnenden
Germany
+49 (0) 7195-12-0



(04.17)

4931 4148 57