

BEDGEBURY & KINSLEY FRENCH PATIO DOORSET FITTING & FIXING GUIDELINES



CAUTION SAFETY: This product needs to be installed by a competent tradesperson with assistance. Two people are required to carry out the installation, as some components are heavy.

IMPORTANT: See notes on Page 2. You can only assemble this doorset using the frame provided. Your warranty will be invalid if other alternatives are used.

Contents

Introduction.....	02
Finishing and care.....	03/04
Tools required.....	05
What you receive.....	05/06
Structural opening guidance.....	07
Frame assembly.....	07
Installing the frame.....	08
Fitting the hinges.....	09
Hanging the doors.....	09
Adjusting the hinges.....	10
Fastening the restrictor.....	10
Fitting handles.....	11
Fitting rain deflectors.....	11
Adjusting the keeps.....	12
Maintenance.....	13
Guarantees.....	14
Trouble shooting.....	15

Introduction

Thank you for purchasing a Bedgebury/Kinsley French Doorset from JELD-WEN.

Your Bedgebury & Kinsley Doorset will be supplied as a French double Doorset. Wherever possible all machining has been completed for you, however there are certain operations you will need to undertake during installation.

JELD-WEN timber doorsets are designed and manufactured in Britain and are fully weather stripped to improve performance. Glazing is supplied with toughened safety glass to BSEN12150.

IMPORTANT:

Installation of these doorsets should be carried out by a minimum of two people.
Prior to installing this doorset please ensure you have carefully inspected each package. In the unlikely event you discover any damage or defect do not proceed to fit until you have notified JELD-WEN (0845 122 2893 option 3)
This doorset and all its components should be stored in a dry flat location prior to and during installation.

The doorset is supplied with an unassembled frame and separate door leaves, with all the components you need for easy assembly.

Before commencing read through these instructions very carefully locating and identifying each component.

Bedgebury/Kinsley doorsets are supplied factory finished. Depending on the product you have purchased i.e. Factory finished, varying levels of additional finishing may be required. Where additional machining has been carried out all untreated surfaces should be suitably decorated.

Please now refer to pg 3-4 for more information.

1 Patio doorset finishing and care instructions

Bedgebury & Kinsley doorsets are supplied factory finished.

Fully Finished Doorsets

Are supplied with the frame and doors fully decorated requiring no further finishing. The timber sill maybe supplied basecoat stained and this should be fully finished prior to installation.

Handling

When handling these doors care is required to avoid physical damage, use clean gloves and do not drag doors across each other or other surfaces.

Biocide Regulations 1st September 2013

Preserved wood should not be cut or otherwise reworked as this will expose un-preserved wood. Any surface which is exposed by cutting or drilling must be re-treated with an HSE approved cut end preservative. Follow the instructions for safe use on the manufacturers' safety data sheet.

Due to the hardwood materials' natural durability qualities no preservative has been applied.

Storage

Doors must be stored in a flat position, and not on an edge or an end. They must be on a level surface and kept clear of the floor on at least three level bearers. The bearers must be longer than the width of the door, and they must be stored in a clean, dry location and should be fully sealed before use. Exposure to sunlight, UV light or extremes of humidity and heat must be avoided, and doors should never be stored in areas which are subject to extremes in temperature. The storage area should have good ventilation and must not have been recently plastered. Special attention should be made in a centrally heated or air-conditioned building where moisture content could build up. Warranty claims for twisting, bowing, shrinking, or swelling that are moisture related (while the doors are not sealed according to our guidelines) will be rejected.

Sealing

Prior to priming or sealing, lightly sand any handling marks or variations caused by exposure and ensure the door is dust free. Do not use wire wool or other sanding materials with steel or iron elements. Knotting solution must be reapplied if knots become visible. It is important that the door is then fully sealed using a suitable base sealer on both faces and all four edges, plus any cut-outs for locks, hinges and letter plates etc. Use two coats of base sealer or primer. Failing to seal doors as suggested in our instructions will invalidate any warranty claims.

Hanging the door

Prior to hanging this door, inspect for damage and do not proceed to work on it if any damage or defect is evident. Installation of the door constitutes acceptance of aesthetics quality. Never hang a door before applying a protective coat of basecoat stain/primer. All lock or Handle cavities should be kept to a minimum size and situated away from any joints, these area's must then be re-sealed.

These doorsets and all components must be fully decorated on site prior to installation. You must use a suitable Hi-Build paint or stain. These doorsets are manufactured using a finger jointed and engineered construction. The timber used is a natural sustainable product, and if not correctly decorated is subject to changes caused by variation in humidity and temperature. If these doors are exposed to these changes without the correct decoration, movement or distortion such as swelling, shrinking, warping or splitting will occur. Warp in the plane of the door will only be considered a defect if it exceeds 6mm when measured, as deviation from a straight edge on the suspected concave surface of the door in its installed position.



All JELD-WEN factory glazed doorsets carry the CE Mark in line with the requirements of the Construction Products Regulations.

1 Patio doorset finishing and care Instructions cont...

Maintenance of fully finished products

JELD-WEN fully finished doorsets have a Hi-Build factory applied paint (or stained) finish. It is tough, durable and microporous allowing the timber to breathe, protecting build up of excess moisture under the coating.

Modest maintenance of the paint coating is important to ensure the long service of these products.

Step by Step maintenance guide

1. Bi-annual Inspection: The paint finish should be inspected for damage, typically caused by a window cleaners ladder or objects being passed through the doorset or window.
If damage is found it must be dealt with promptly by sanding back to the undamaged frame and touching up with a matching microporous paint and top coat.
2. Planned Maintenance: for all factory finished products will depend on your location and exposure – maritime or industrial areas will require more regular decoration than sheltered inland climates. Please refer to www.JELD-WEN.co.uk for further information.

The first maintenance cycle should be carried out, regardless of the appearance of the doorset. The original paint finish in exposed areas will have worn away to around half its original specification and will need to be restored back to its original state. Simply wash the frame down with a dilute soap solution, dry and lightly rub down the surface with fine ‘wet and dry’ sandpaper, grit (280 to 400) grade. Dust off and clean using a damp cloth removing any remaining surrounding dust, then apply one top coat of microporous paint* over the exposed surfaces.

There should be no need to paint rebates or concealed faces as these should be in good condition and no erosion should have occurred. The doorset finish should then be in good condition until next planned maintenance, recommended in 7 years, unless in an area of high exposure.

Decoration

All doorsets must be finished with Hi-Build based stains or paints. Our doorsets are not suitable for varnishes, waxes, polishes or oils as these products do not correctly seal the doorsets. Three top coats of a branded stain or paint are satisfactory, but doorsets must be treated in accordance with the stain/paint manufacturer's instructions. A light sanding between coats will provide the best finish, and adequate drying time between coats

must be allowed. Failure to follow these instructions will invalidate any claims.

‘Low Build’ stains, varnishes, Danish Oil or any other finishes must **not** be used. Pigmented translucent finishes generally perform much better than clear. It is recommended that dark coloured stains or paint should be avoided particularly if the doorset is exposed to the full heat of the sun, particularly on south or south west elevations. Dark finishes increase surface temperatures and cause excessive drying out; this can lead to surface deterioration requiring more regular maintenance.

We recommend that in areas of severe exposure, external doorsets should be protected by a porch or hood/canopy in addition to the recommended decorative finish. Regular maintenance of this doorsets should be made to prevent deterioration of the wood, its construction and the finish.

* Microporous paint can be used that are either water or solvent (oil) based. Manufacturers instructions must be followed paying particular attention to temperature at the time of application.

Condition of Sale

In the event of this door being proven to have a manufacturing defect, where a replacement is needed, the liability of the seller shall under no circumstances exceed the price of the defective door. We shall not be held responsible for any incidental work or for problems resulting from poor workmanship applied to our doors.

Due to the construction of engineered timber:

- finger/laminate joints maybe visible on the finished product.
- visible grain can vary between individual engineered sections.
- timber is a natural product and will swell or shrink to varying degrees dependent on location etc.

Glass units

- Defects will only be considered under the standards of the GGF Code of Good Practice
- Due to the high thermal properties of insulating glass units, condensation may form on external faces of the glass units if environmental conditions allow.

Thermal Bridging

- in certain applications this may result in condensation forming on the products metallic surfaces.

The foregoing does not affect your statutory rights.

For more information please refer to our website www.JELD-WEN.co.uk

Building Regulations:

Please consult with your building designer to ensure compliance with current building regulations such as Approved Documents L&F.

Replacing doorsets is notifiable work and MUST either be carried out by a FENSA or other registered installer, or with prior Building Control approval.

Registered FENSA companies can be found at www.fensa.co.uk.

2 Tools required

The following tools and items are required to carry out the installation of the doorset.

- Spirit level
- Power drill
- Screwdriver or power driver
- Measuring tape
- Appropriate Silicone sealant
- Mallet - rubber headed
- Screw head bit
- Timber drill bit 3mm (pre-drilling)
- Timber drill bit 5mm
- Masonry drill bit 5mm dia
- Damp proof course (d.p.c.)
- Appropriate external adhesive
- 30mm timber pins

3 What you receive

The doorset and all its components are delivered on a pallet, check quantities on your delivery ticket are the same as those on the pallet.

If there are any items missing phone JELD-WEN on: 0845 122 2893 option 3.

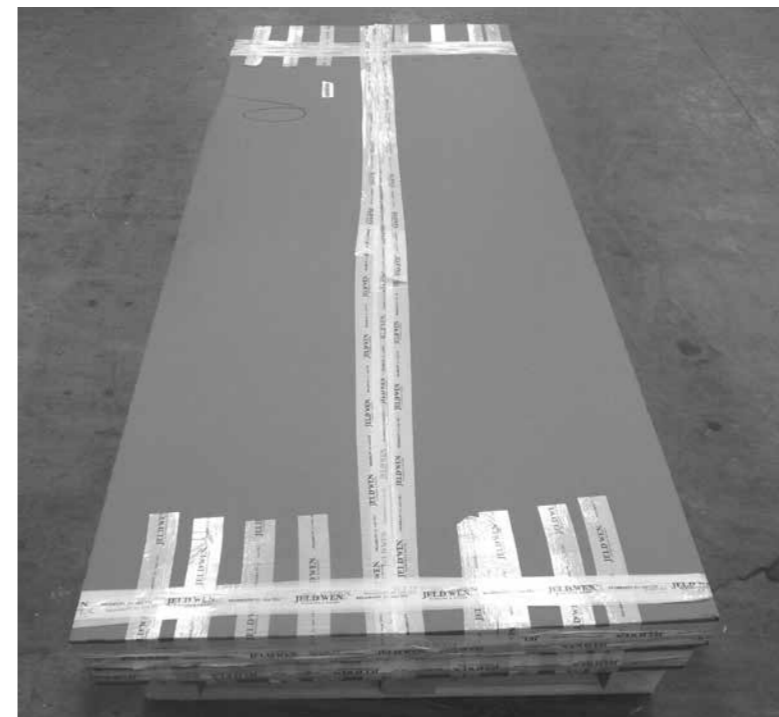

This pallet contains two door boxes and the frame pack

3 What you receive cont...

Pallet contents: Door leaves (boxed individually)

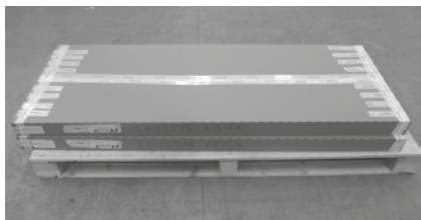

Door leaves (boxed individually)



Hardware Pack



Fitting Instructions Booklets



Locking Handles



Hinges - 3 Pairs per leaf



Fixings pack

Contents
48 no 4.5mm x 40mm screws
1 no 3mm square allen key



Sill Keep (pre-fitted)



Frame: supplied unassembled



Head keep (pre-fitted)



Centre double keep (pre-fitted)

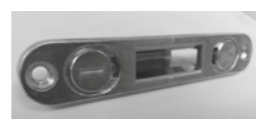

Top and bottom hook keep (pre-fitted)

4 Structural opening

It is recommended that the opening into which the Doorset is to be installed is 12mm larger in both height and width than the overall doorset sizes given in the table below:

Module Size	Actual Frame Width	Actual Frame Height
1200	1194	2094
1500	1494	2094
1800	1794	2094

Structural Opening

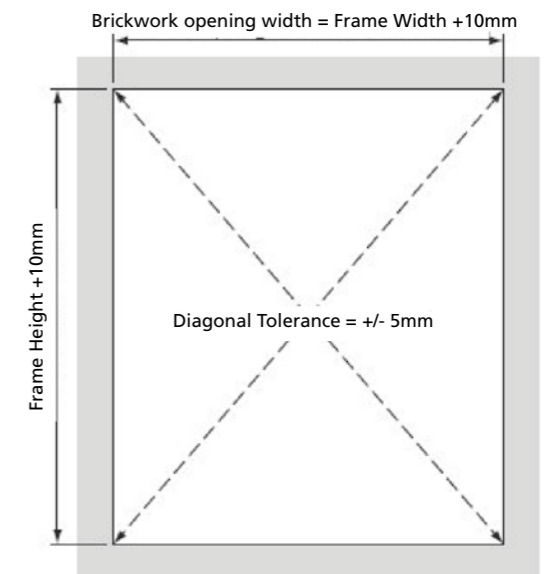

5 Frame assembly

The frame is supplied with cut outs for hinges and pre-machined for the espagnolette and flush bolt keeps.

Assemble the frame on a level surface. Pilot holes are required prior to fixing screws.

Glue all comb joints with waterproof adhesive and screw through the joint with 4.0 x 90mm screws 10 gauge (not supplied).

Check the frame is square and temporarily brace as necessary to ensure stability of the frame (See Fig 1).

Glue and screw all joints.

The threshold strip is supplied pre-fitted to the timber sill.

Prior to assembling the frame run a bead of silicone along the end of the threshold and the frame jamb.

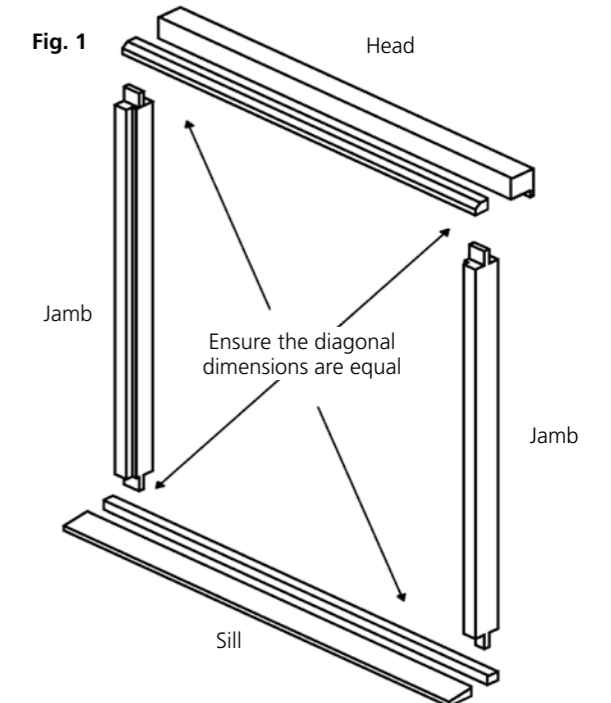

6 Installing the frame

Make sure the frame is square and parallel ie diagonal, vertical and horizontal dimensions are equal. Use suitable packers to adjust the frame into position as needed.

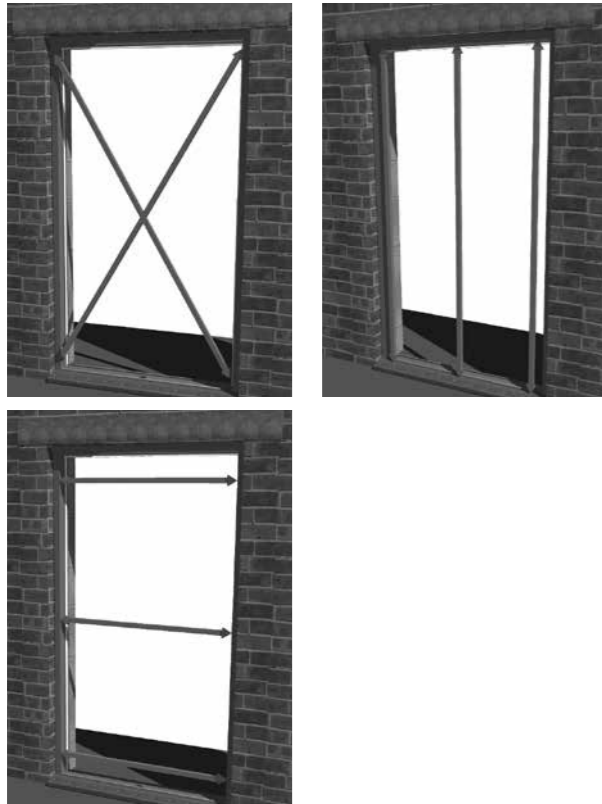

Pack around the frame to ensure the frame is square and plumb in the opening.

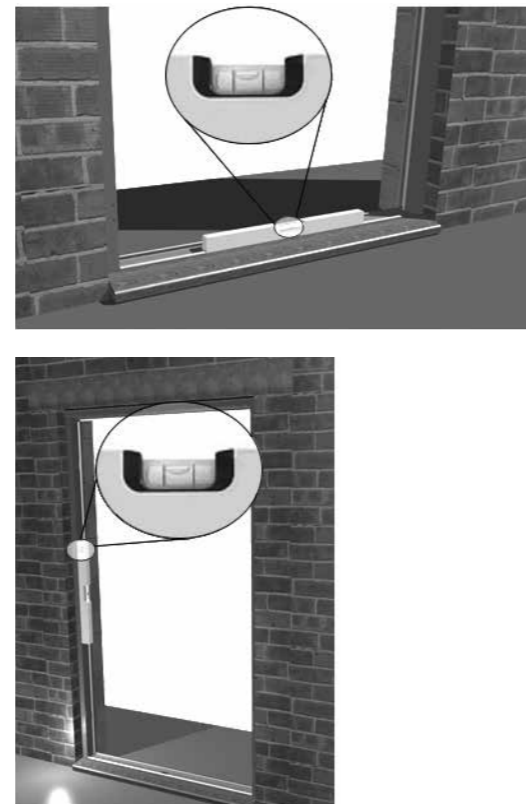

Where possible fix through the frame into the brickwork using suitable frame fixings bolts/screws. Alternatively fixing straps can be used. The frame should be pilot drilled prior to final installation. Frame fixings are recommended to each jamb at 150mm from top and bottom and then at 450mm centres, a minimum of four fixings. It is advisable that the head and sill are secured at the centre using a fixing strap. See Fig a & b.

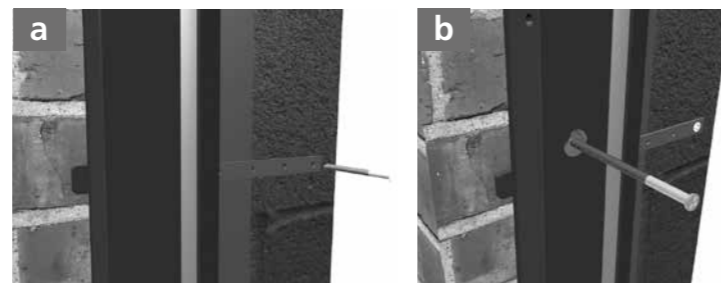

A 30mm setback over the cavity will ensure compliance to Part L - Robust Detail (Other installation details maybe specified by your building designer)

7 Fitting the hinges

Fix the hinge base to door leaf c.

DO NOT REMOVE THE ADJUSTMENT INSTRUCTION LABEL FROM THE HINGE

The hinges can only be fitted in one orientation due to the pre-routed cut outs on the door leaf with the metal face upwards. The deeper half of the hinge should be placed into these the furthest away from the edge of the leaf as possible.

Using the 4.0 X 40mm Screws ensure all screw positions are fixed on all three hinges.

*Note: DO NOT adjust hinges until necessary

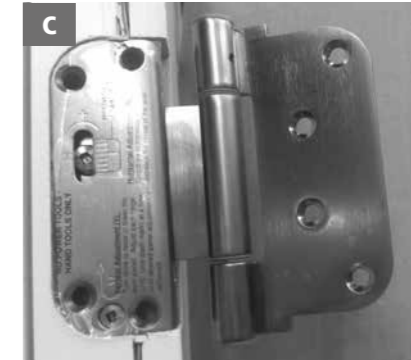

8 Hanging the doors – Best completed as a 2 person operation

Once the hinge flag is attached to the door leaf, it can be fitted to the frame using a two or three man lift (make your own suitable health and safety assessment) ensuring the bottom of the door is offered to the sill end of the frame, hold in position.

Lining up the hinge flag screw holes with the pre-drilled pilot holes on the frame, screw into place using more of the 4.0 X 40mm Screws. Repeat the above for double door.

The locking door is supplied with the lock pre-fitted to the RH door (viewed from outside). To change to a LH door remove the lock and rotate the door 180 degrees before re-fitting the lock.

Once the handing of the door is determined and therefore also the top and bottom edges are established additional holes needs to be prepared through the central mortice as shown on the template on the back page.

Once the doorset has all the leaves hung, the hinges can be adjusted for smoother operation using the allen key provided.



9a Adjusting the hinges

The hinge has two directions of adjustment, shown on the label fixed to its face.

DO NOT REMOVE THIS LABEL FROM THE HINGE

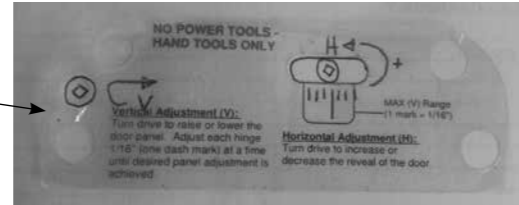

H (Horizontal – fig 1.) Turns in the direction of the arrow will move the door leaf horizontally increasing or decreasing the gap between the door leaf and frame. Aim for around a 5mm +/-1mm gap side to side for optimum performance.

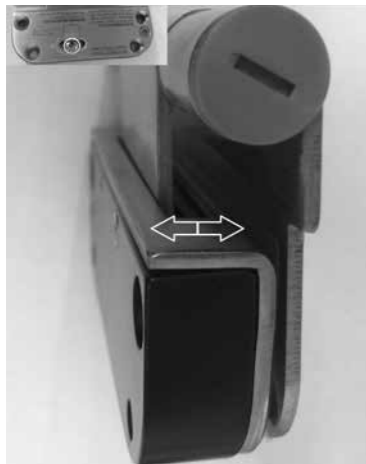

Fig 1

V (Vertical – fig 2.) Turns in the direction of the arrow will move the door leaf vertically upwards towards the top of frame (head) or vertically downwards towards the sill.



Fig 2

Using small turns adjust each hinge in turn the same amount until the level of adjustment required is reached.

Warning: DO NOT OVERTURN BOLTS, FAILURE TO CORRECTLY ADJUST THE DOORS MAY RESULT IN DAMAGE

9 Fastening the restrictor

The restrictor is supplied loose for each door and should be fitted once the handing has been determined.

The restrictor should be fitted 80mm from the hinge side of the door facing towards the opening end. The block should be fitted into the recess on the underside of the frame head.

If you wish to alter the amount of restriction this can be done by moving the block in the top of the door to a different fixing position, there are a number of pre-drilled positions to select.

The force required to open the door leaf can be adjusted by tightening or loosening the brass screw in the white block, see diagram opposite.

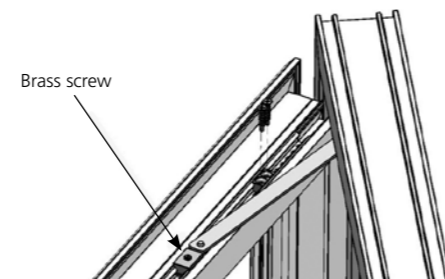

The restrictor is not designed to, and it will not prevent the door from blowing open if the doors are not secured.

10 Fitting handles

Once the handing of the door is determined using the template provided prepare the additional handles

Insert Cylinder through shaped cutout, ensuring correct engagement with locking gearbox. Insert the 45mm length screw provided through the locking bar on the edge of the door leaf ensuring it engages correctly through the cylinder and is tightened fully.

Insert Spindle and locate handles over cylinder and spindle, ensuring the handle with the bolt heads showing is on the inside and levers are facing in towards the glass. Using the bolts supplied screw in until tight and handle is secure.

Check lock operation and if necessary slightly loosen handle bolts to ensure full locking is achieved. I.e. hooks are fully engaged and handle can be lifted, smoothly to it's full extent.

11 Fitting rain deflectors

Use the screws provided to fix the rain deflectors to the bottom of the doors and attach the end caps.

Apply a small bead of silicone along the back edge prior to screwing in place.

Fit the rain deflector with the bottom edge parallel with the bottom of the door.

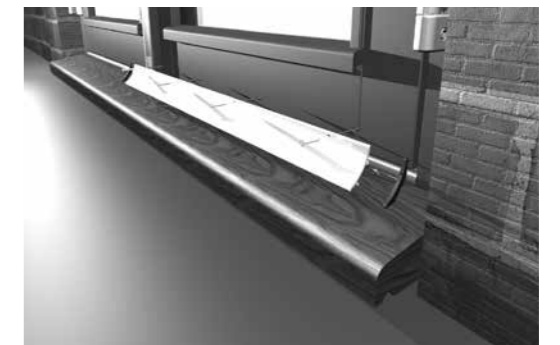

The deflector should not be fixed so it is low enough to touch the sill.

12 Adjusting the keeps

a

Head & Sill Keeps

Undo both screws and nudge top plate towards the outside to close doors tighter for Open In, or to set door further from the frame for Open Out.

To achieve the opposite pull top plate back towards inside. Re-tighten both screws.



Head keep



Sill keep

b

Lock Keeps

Centre lock keep turn both cams the same distance in opposing directions, to close the door tighter against its frame ensure the hook box is moving; towards the outside of the dwelling for open out, towards the inside of the dwelling for open in.

To achieve the opposite turns cams in reverse.



Top & bottom Hook keeps turn both cams the same distance in opposing directions, to close the door tighter against its frame ensure the hook box is moving towards the outside of the dwelling for open in. Ensure the hook box is moving towards the inside of the dwelling for open out.

To achieve the opposite turns cams in reverse.

IMPORTANT: Adjust Head and Sill and Lock keeps in small, even amounts to ensure door operates correctly.



13 Finishing & maintenance

Please also refer to Section 1

Finishing

After finishing the installation of your doorset, check that all the fixings are secure, all the specified dimensions are achieved and the seals are correctly fitted. This is vital for the proper operation and long life of your Patio doorset.

Factory finished requires no further decoration other than touching up damage that may have occurred during installation. This should be carried out in dry weather conditions. Any cutouts or additional machining during installation should also be fully decorated. Before priming or sealing lightly sand off any handling marks and variations caused by exposure and ensure the surface is dust free.

Microporous paints and Hi-Build wood stains are recommended for all exterior products. The manufacturer's instructions should be followed.

'Low Build' stains, varnishes, Danish Oil or any other finishes should **not** be used. Pigmented translucent finishes generally perform much better than clear. It is recommended that dark coloured stains or paint should be avoided if the doorset is exposed to the full heat of the sun, particularly on south or south west elevations. Dark finishes increase surface temperatures and cause excessive drying out; this can lead to surface deterioration requiring more regular maintenance.

We recommend in area's of severe exposure external doors should be protected by a porch or hood/canopy in addition to the recommended decorative finish. Regular maintenance of this door should be made to prevent deterioration of the wood, it's construction and the finish.

Maintenance

These products must be installed in accordance with accepted good trade practice (and in accordance with supplied instructions where applicable), and maintained in accordance with these procedures or else the warranty shall be void.

Automatic Closers and Operators

All Door Hardware systems supplied are designed for manual operation only.

Hardware

Handles, hinges and bearings in buildings are subject to deterioration from everyday use, and also from environmental attack due to atmospheric and other conditions. Maintenance of hardware is even more important in severe environments such as coastal marine areas, and some industrial areas. Even stainless steel products require maintenance to prevent deterioration in some environments. JELD-WEN UK Ltd requires the following minimum maintenance to be followed otherwise the warranty shall be void.

Hinges

Wipe down the visible surfaces with warm soapy water on a soft rag and then rinse off by wiping with a clean damp rag. Application of a thin film of a light machine oil or one of the corrosion preventative sprays will help to maintain the original lustre of the metal finish. Be careful not to get these compounds on the timberwork itself as they may cause staining.

Adjustment

Timber is a natural product and therefore performs differently through the seasons of the year.

Frequency

The procedures mentioned above need to be carried out as often as is necessary to prevent deterioration in the installed environment, however we recommend the following minimum frequency of application:

- General environments 6 monthly
- Marine and industrial environments 3 monthly

Regular maintenance is required to all hardware, even stainless steel; otherwise the manufacturer's warranty may be voided.

All hardware should be regularly cleaned using a soft cloth and mild detergent to prevent build up of pollutants such as salt etc. In maritime and industrial environments the intervals should become shorter in some instances weekly cleaning may be required. Harsh chemical cleaners and abrasive materials should be avoided at all times.

Glass Units

Shattering caused by thermal shock and scratches, to external glass faces not reported at time of delivery, are not covered under the JELD-WEN product guarantees.

14 Guarantees

In keeping with our quality policy, JELD-WEN offers the following guarantees on its products. These guarantees are subject to JELD-WEN UK Terms and Conditions of Sale. Defects that are caused in whole or in part by failure to adhere to JELD-WEN UK recommendations relating to storage, handling, installation, decoration, glazing and maintenance, are not covered by the guarantees below:



Exceptional wear and tear of hardware through extreme use is not covered. JELD-WEN will accept no responsibility for products cut down in size after receipt, or when utility or structural strength is impaired in fitting or application of hardware.

Hinges, aluminium rails and other hardware fitted must never be painted, and must be kept clean and lightly lubricated at all times. Use Vaseline or neutral oil. Keep rivets and moving parts lightly lubricated. Lubricate at least once a year, in coastal areas and/or places with high pollution, clean and lubricate more often.

All joinery shall be installed correctly in accordance with normal trade practices and adequately maintained in service.

The decorative finish applied to external joinery must be maintained in service and moisture must not be allowed to penetrate into the timber throughout its life.

Regular maintenance of the paint or stain finish of the product is essential for the long-term performance of all the components of your patio doorset. The period between maintenance checks will vary depending on the type of paint or stain finish and also the local conditions for the site. External joinery products must be cleaned at a maximum of six monthly intervals using a mild non-abrasive cleaner and soft cloth. Both internal and exterior faces should be cleaned.

Make regular checks to ensure that any drainage holes, channels and spaces are kept clear. Use a soft flexible brush or pipe cleaner with care to remove obstructions.

Annual inspection should be made and touching up carried out as necessary in areas of wear and tear (for example, exposed areas of sills or where the paint film has been breached).

Guarantees to the finished product are also on condition that:

- No physical or chemical damage to the doorset or coating has occurred
- No repairs or alterations to the surrounding buildings have occurred which are detrimental to the joinery performance.
- No failure of the coating has occurred caused by failure of ancillary products, or glazing.
- No damage to the coatings has occurred prior to, or during, installation.
- No damage to the coating has occurred, caused by bad maintenance of the building or poor design of the building.

15 Troubleshooting guide

My door doesn't lock why?

Try the lock operation with the door open to check the mechanism is working correctly.

If no, check handle fitment.

If yes, try the following steps.

Adjust hinges horizontally away from the hinge side. See Section 9a.

Adjust keeps centre and hook keeps. See Section 12.

Adjust Head and Sill keeps. See Section 12.

Check the multipoint lock is engaging correctly - if not follow the steps below.

Adjust hinges horizontally away from the hinge side. See Section 9a.

Adjust keeps centre and hook keeps. See Section 12.

Adjust Head and Sill keeps. See Section 12.

There is a lot of resistance against the door shutting on the weatherseal.

If the restrictor blocks in the top of the door are incorrectly positioned, this can cause the door to bind or feel 'hinge bound' - easily checked by releasing the restrictor from the head and trying the door again. If it is OK, reposition the block. If not, try the following steps.

Adjust hinges accordingly. See Section 9a.

Adjust Head and Sill keeps. See section 12.

My door leaf is binding on head or sill.

Ensure frame is square.

Adjust Hinges Vertically. See Section 8a.

How often should I decorate my doors?

This will depend on the exposure environment of the location - severe industrial or maritime locations will require more frequent decoration than sheltered.

It is recommended that every six months you check the finish and wipe down all surfaces with a damp cloth.

Any signs of damage/wear to the finish will require redecoration. follow the instructions within this document in Section 13.

My doors 'rattle'

The keeps require adjustment. Slave door should be get with minimal movement when in the closed position.

Excessive play will cause the doors to rattle/make them difficult to lock/latch and reduce effectiveness of the compression seals. See Section 12.

How often do I have to clean the hardware?

This will depend on the exposure environment of the location - severe industrial or maritime locations will require more frequent cleaning than sheltered. Follow the instructions within this document. See Section 13.

Do I need to clean the handles?

Yes build up of environmental deposits such as salt will damage the finish. A wipe down with a soft non abrasive cloth will be required, the frequency will depend on the location - maritime locations a minimum of once a month possibly more frequent. See Section 13.

Door handle template

Please use this template when fixing the door handle, it is to scale. All dimensions are in mm.

