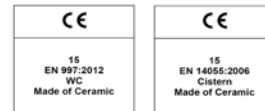
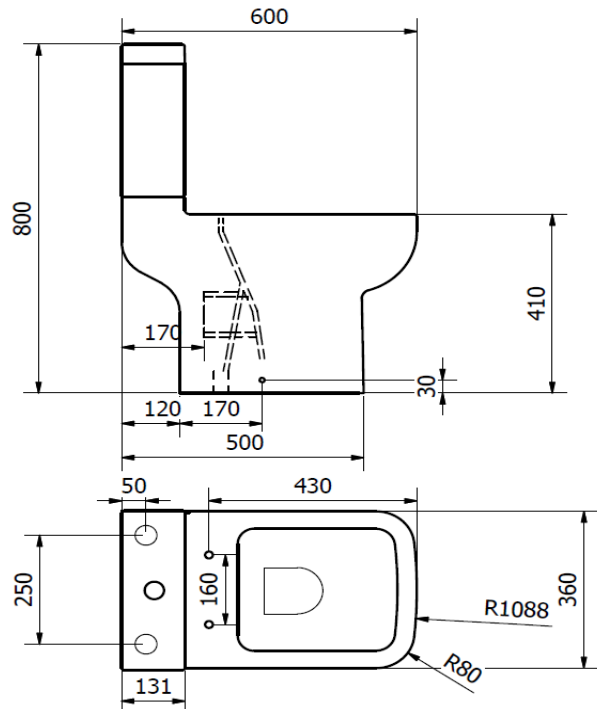
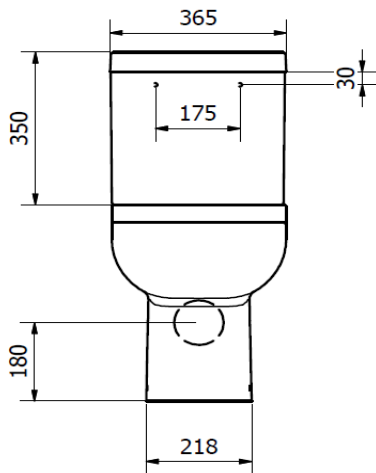

OPTIONS 600 C/C PAN, SEAT & CISTERN

ILLUSTRATION: OPTIONS C/C PAN & CISTERN
**CODE: C/C WC PAN - POT0800P
 C/C CISTERN - POT450SE
 SOFT CLOSE SEAT - POT0820P
 PREMIUM S/C SEAT - POT0840P**
COLOUR: WHITE

WEIGHT:	WC PAN	CISTERN	SEAT	P SEAT
NET:	27.5 KG	11 KG	1.4 KG	2.3 KG
GROSS:	28.5 KG	12 KG	1.6 KG	2.5 KG

**STANDARDS: BS EN 997 WCs
 BS EN 14055:2010 FLUSHING CISTERNS
 BS 3402**

**NOTES:
 VITREOUS CHINA
 WATER SAVING 6/4 LITRE FLUSH
 SOFT CLOSE SEAT WITH QUICK RELEASE TOP FIX HINGE**

BOX SIZES :- WC PAN = 390 X 490 X 640 mm / CISTERN = 1155 X 380 X 390 mm / SEAT = 450 X 370 X 55 mm