

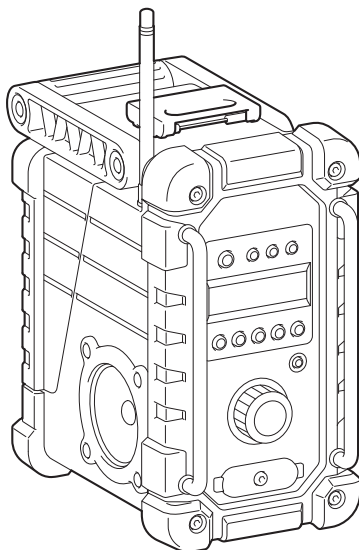

# Job Site Radio

DMR109



Read before use.

## ENGLISH (Original instructions)

### SYMBOLS

The following show the symbols used for the equipment. Be sure that you understand their meaning before use.



..... Read instruction manual.



..... Only for EU countries  
Do not dispose of electric equipment or battery pack together with household waste material!  
In observance of the European Directives, on Waste Electric and Electronic Equipment and Batteries and Accumulators and Waste Batteries and Accumulators and their implementation in accordance with national laws, electric equipment and batteries and battery pack(s) that have reached the end of their life must be collected separately and returned to an environmentally compatible recycling facility.

Cd  
Ni-MH  
Li-Ion

DAB: The name "DAB" in this manual indicates "Digital Radio".

### IMPORTANT SAFETY INSTRUCTIONS

#### **WARNING:**

When using electric tools, basic safety precautions should always be followed to reduce the risk of fire, electric shock, and personal injury, including the following:

1. Read this instruction manual and the charger instruction manual carefully before use.
2. Clean only with dry cloth.
3. Do not install near any heat sources such as radiators, heat registers, stoves, or other apparatus (including amplifiers) that produce heat.
4. Only use attachments/accessories specified by the manufacturer.
5. Unplug this apparatus during lightning storms or when unused for long periods of time.
6. A battery operated radio with integral batteries or a separate battery pack must be recharged only with the specified charger for the battery. A charger that may be suitable for one type of battery may create a risk of fire when used with another battery.
7. Use battery operated radio only with specifically designated battery packs. Use of any other batteries may create a risk of fire.
8. When battery pack is not in use, keep it away from other metal objects like: paper clips, coins, keys, nails, screws, or other small metal objects that can make a connection from one terminal to another. Shorting the battery terminals together may cause sparks, burns, or a fire.
9. Avoid body contact with grounded surfaces such as pipes, radiators, ranges and refrigerators. There is an

increased risk of electric shock if your body is grounded.

10. Under abusive conditions, liquid may be ejected from the battery; avoid contact. If contact accidentally occurs, flush with water. If liquid contacts eyes, additionally seek medical help. Liquid ejected from the battery may cause irritation or burns.
11. The MAINS plug is used as the disconnect device, and it shall remain readily operable.

## SAVE THESE INSTRUCTIONS

### IMPORTANT SAFETY INSTRUCTIONS FOR BATTERY CARTRIDGE

1. Before using battery cartridge, read all instructions and cautionary markings on (1) battery charger, (2) battery, and (3) product using battery.
2. Do not disassemble battery cartridge.
3. If operating time has become excessively shorter, stop operating immediately. It may result in a risk of overheating, possible burns and even an explosion.
4. If electrolyte gets into your eyes, rinse them out with clear water and seek medical attention right away. It may result in loss of your eyesight.
5. Do not short the battery cartridge:
  - (1) Do not touch the terminals with any conductive material.
  - (2) Avoid storing battery cartridge in a container with other metal objects such as nails, coins, etc.
  - (3) Do not expose battery cartridge to water or rain. A battery short can cause a large current flow, overheating, possible burns and even a breakdown.
6. Do not store the tool and battery cartridge in locations where the temperature may reach or exceed 50°C (122°F).
7. Do not incinerate the battery cartridge even if it is severely damaged or is completely worn out. The battery cartridge can explode in a fire.
8. Be careful not to drop or strike battery.
9. Do not use a damaged battery.
10. The contained lithium-ion-batteries are subject to the Dangerous Goods Legislation requirements. For commercial transports e.g. by third parties, forwarding agents, special requirement on packaging and labeling must be observed.  
For preparation of the item being shipped, consulting an expert for hazardous material is required. Please also observe possibly more detailed national regulations.  
Tape or mask off open contacts and pack up the battery in such a manner that it cannot move around in the packaging.
11. Follow your local regulations relating to disposal of battery.

## SAVE THESE INSTRUCTIONS.

 **CAUTION:** Only use genuine Makita batteries. Use of non-genuine Makita batteries, or batteries that have been altered, may result in the battery bursting causing fires, personal injury and damage. It will also void the Makita warranty for the Makita tool and charger.

### Tips for maintaining maximum battery life

1. Charge the battery cartridge before completely discharged.  
Always stop tool operation and charge the battery cartridge when you notice less tool power.
2. Never recharge a fully charged battery cartridge.  
Overcharging shortens the battery service life.
3. Charge the battery cartridge with room temperature at 10°C - 40°C (50°F - 104°F). Let a hot battery cartridge cool down before charging it.
4. Charge the battery cartridge if you do not use it for a long period (more than six months).

## EXPLANATION OF GENERAL VIEW

- |                                      |  |   |
|--------------------------------------|--|---|
| 1. Power button                      | 8. DC IN socket  | 14. Speaker                             |
| 2. Band button                       | 9. AUX IN 1  | 15. Battery compartment locker          |
| 3. Advanced setting button           | 10. LCD display  | 16. Input terminal (AUX IN 2)           |
| 4. Info button                       | 11. Soft bended rod antenna                                | 17. Micro USB port for software upgrade |
| 5. Preset button                     | 12. Handle   |   |
| 6. Auto tune button                  | 13. Battery compartment cover (covering battery cartridge) |   |
| 7. Volume/Tuning Control/Select knob |  |   |

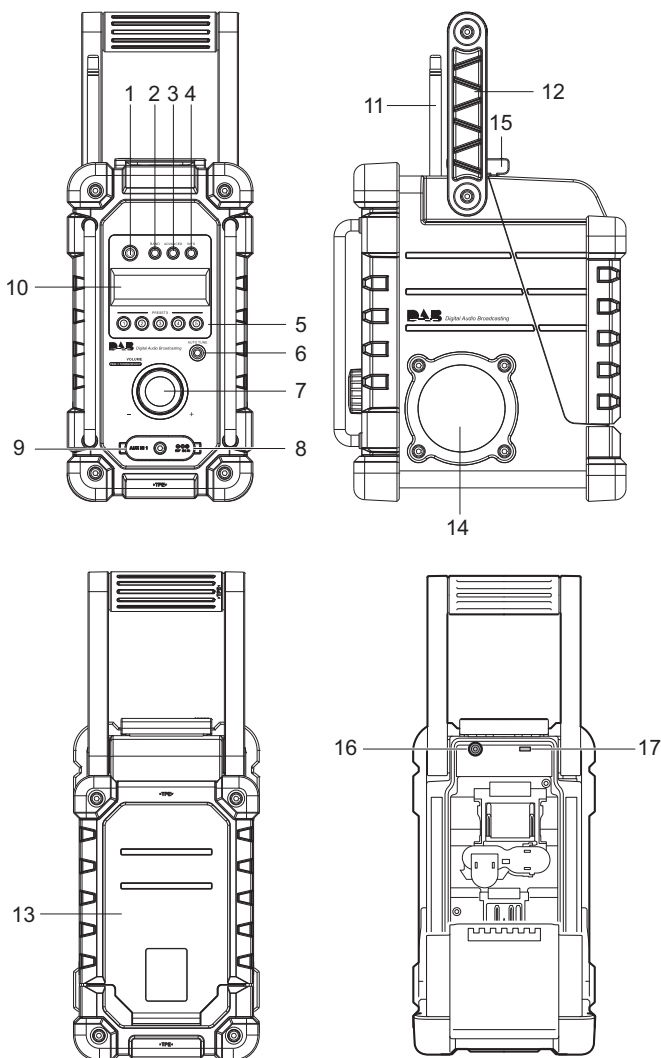

## FEATURES

- FM/DAB
- Large LCD display with illumination
- Manual/Preset/Scan tuning
- Rotary tuning and volume control
- 5 preset stations for each band
- Micro USB port for software upgrade
- Stereo speaker for rich sound performance
- Ultra rugged design
- Water resistant to IP64
- Powered by both Makita battery pack and supplied power adaptor

## OPERATING TIME

The following tables indicate the operating time with a full charged battery.

Battery capacity	Battery cartridge voltage				At speaker output = 50 mW + 50 mW Unit: Hour (Approximately)
	7.2 V	10.8 V	14.4 V	18 V	
1.0 Ah	BL7010				4.5 hour
1.3 Ah		BL1013			5.5 hour
			BL1415		5.0 hour
				BL1815	6.0 hour
1.5 Ah	BL0715				6.5 hour
		BL1015			8.0 hour
			BL1415N		7.0 hour
				BL1815N	7.5 hour
2.0 Ah		BL1020B		BL1820 BL1820B	10 hour
3.0 Ah			BL1430 BL1430B		11 hour
				BL1830 BL1830B	14 hour
4.0 Ah		BL1040B		BL1840 BL1840B	20 hour
			BL1440		18 hour
5.0 Ah			BL1450		22 hour
				BL1850 BL1850B	25 hour
6.0 Ah			BL1460B		24 hour
				BL1860B	31 hour

: Cluster battery    : Slide battery

\* The operating time is based on the operation in DAB on a single charge.

\* Operating time may differ depending on battery type, charging status, and usage condition.

## INSTALLATION

### Installing or removing Slide battery cartridge

**⚠ CAUTION:** Always switch off the radio before removing the battery cartridge.

- To install the battery cartridge, align the tongue on the battery cartridge with the groove in the housing and slip it into place. Always insert it all the way until it locks in place with a little click.
- If you can see the red indicator on the upper side of the button, it is not locked completely. Install it fully until the red indicator cannot be seen. If not, it may accidentally

fall out of the radio, causing injury to you or someone around you.

- Do not use force when installing the battery cartridge. If the cartridge does not slide in easily, it is not being inserted correctly.
- To remove the battery cartridge, slide it from the radio while sliding the button on the front of the cartridge or pressing the buttons on both sides of the cartridge.

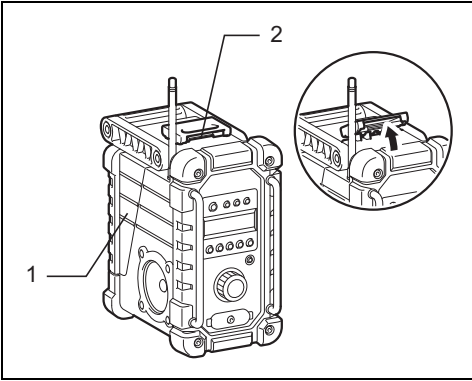

1. Battery compartment
2. Battery compartment locker

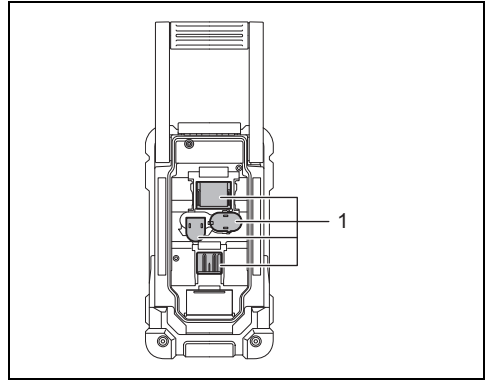

1. Battery compartment

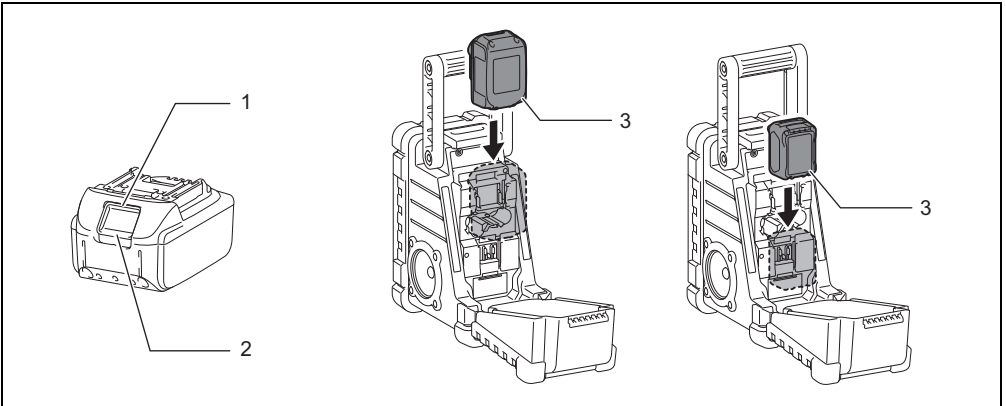

1. Red indicator
2. Button
3. Battery cartridge

Return the battery compartment locker to the original position. Reduced power, distortion and a “stuttering sound” are signs that the battery needs to be replaced.

**Note:**

The battery pack can't be charged via the supplied AC power adaptor.

**Installing or removing Cluster battery cartridge**

**⚠ CAUTION:**

Always switch off the radio before removing the battery cartridge.

- To insert the battery cartridge, align the tongue on the battery cartridge with the groove in the housing and slip it into place.

- To remove the battery cartridge, take the battery out of the terminal while pressing the buttons on the side of cartridge.

Return the battery compartment locker to the original position.

Reduced power, distortion and a “stuttering sound” are signs that the battery needs to be replaced.

**Note:**

The battery pack can't be charged via the supplied AC power adaptor.

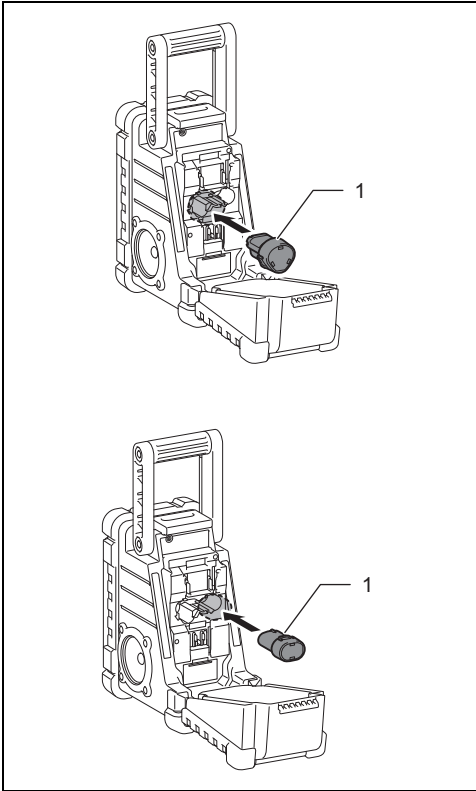

1. Battery cartridge

### Indicating the remaining battery capacity

Only for battery cartridges with "B" at the end of the model number

Press the check button on the battery cartridge to indicate the remaining battery capacity. The indicator lamps light up for few seconds.

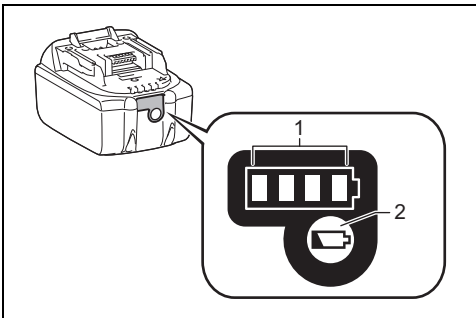

1. Indicator lamps  
2. Check button

Indicator lamps			Remaining capacity
Lighted	Off	Blinking	
■	■	■	75% to 100%
■	■	□	50% to 75%
■	□	□	25% to 50%
■	□	□	0% to 25%
◐	□	□	Charge the battery.
■	□	□	The battery may have malfunctioned.
□	□	■	

**Note:**

- Depending on the conditions of use and the ambient temperature, the indication may differ slightly from the actual capacity.

### Installing the soft bended rod antenna

Install the soft bended rod antenna as shown in the figure.

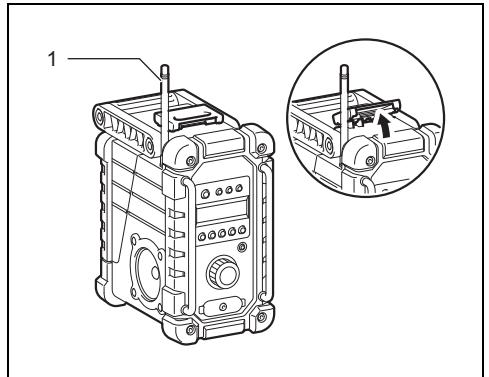

1. Soft bended rod antenna

**Note:**

There is a click in the battery compartment designed to store the removed antenna.

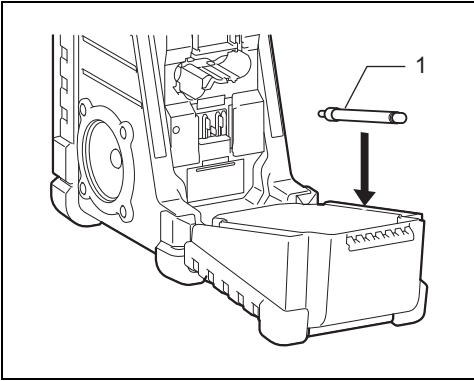

1. Soft bended rod antenna

### Using supplied AC power adaptor

Remove the rubber protector and insert the adaptor plug into the DC socket on the front side of the radio. Plug the adaptor into a standard mains socket outlet. Whenever the adaptor is used, the battery pack is automatically disconnected. The AC adaptor should be disconnected from the main supply when not in use.

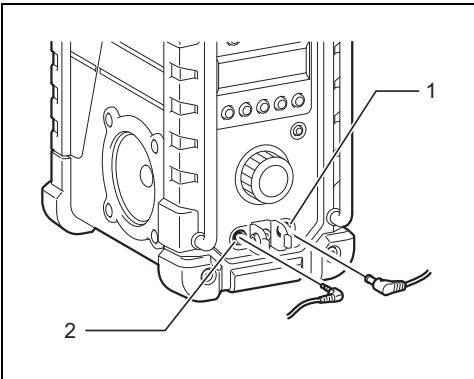

1. DC IN socket  
2. AUX IN 1

## OPERATION

This radio has three tuning methods- Scan tuning, Manual tuning and Memory presets recall.

### Selecting a station - DAB

1. Press the Power button to switch on your radio.
2. Select the DAB mode by pressing the Band button.
3. Press the Advanced setting button and rotate the Volume/Tuning Control/Select knob until "Station List" is flashing on the screen. Press the Volume/Tuning Control/Select knob to enter the list of the stations.

4. Rotate the Volume/Tuning Control/Select knob to scroll through the list of available stations. Press the knob to select the station.
5. Adjust the desired volume by rotating the Volume/Tuning Control/Select knob.

### Display modes - DAB

Your radio has a range of display options in the DAB mode:

Press the Info button to cycle through the various options shown in the following letters (a. to g.).

- |    |                       |  |
|----|-----------------------|--|
| a. | Station name          | Indicates the station name being listened to.  |
| b. | Program type          | Indicates the type of station being listened to. E.g. Pop, Classics, News, etc.          |
| c. | Multiplex name        | Indicates the name of the DAB multiplex to which the current station belongs.            |
| d. | Time & date           | Indicates the current time and date.   |
| e. | Frequency and channel | Indicates the frequency and channel number for the currently tuned DAB station.          |
| f. | Bit rate/Audio type   | Indicates the digital audio bit rate and audio type for the currently tuned DAB station. |
| g. | Signal strength       | Indicates the signal strength for the currently tuned DAB station.                       |

### Finding new stations – DAB

From time to time, new DAB radio stations may become available. Or you may have moved to a different part of the country. In this case you may need to activate your radio to scan for new stations.

To allow the radio to find the available stations, it is recommended to carry out a full scan of the entire DAB Band III frequencies.

1. Press the Auto tune button.
2. Your radio will perform a full scan of the DAB frequencies. As new stations are found, the station counter on the left side in the display will increase and stations will be added to the list.

### Manual tuning – DAB

Manual tuning allows you to tune your radio to a particular DAB frequency in Band III. This function can also be used to assist the positioning of the antenna or the radio so as to optimize reception for a specific channel or frequency.

1. Press the Advanced setting button and rotate the Volume/Tuning Control/Select knob until "Manual Tune" shown on the display. Press the Volume/Tuning Control/Select knob to enter the manual tuning mode.
2. Rotate the Volume/Tuning Control/Select knob to select the desired DAB channel. Press Volume/Tuning Control/Select knob to confirm the chosen frequency.



## Station order setup – DAB

Your radio has 3 station order settings from which you can choose. The station order settings are alphanumeric, ensemble and valid station.

1. Press the Advanced setting button.
2. Rotate the Volume/Tuning Control/Select knob until “Station order” appearing on the display, then press the Volume/Tuning Control/Select knob to enter the setting.
3. Rotate the Volume/Tuning Control/Select knob to select the following options and press the knob to confirm the setting.

Alphanumeric	Sorts the station list alpha-numerically 0...9 A...Z
Ensemble	Organizes the station list by DAB multiplex
Valid	Shows only those stations for which a signal can be found

## Dynamic Range Control (DRC) – DAB

DRC feature can make quieter sounds easier to hear when your radio is used in a noisy environment by reducing the dynamic range of the audio signal. There are three levels of compression:

DRC 0	No compression applied.
DRC 1/2	Medium compression applied.
DRC 1	Maximum compression applied.

1. Press the Power button to switch on your radio.
2. Press the Band button to select the DAB band.
3. Press the Advanced setting button and rotate the Volume/Tuning Control/Select knob until “DRC Value” shown on the display. Then press the Volume/Tuning Control/Select knob to enter the setting. The display will show the current DRC value.
4. Rotate the Volume/Tuning Control/Select knob to select desired DRC setting.
5. Press the Volume/Tuning Control/Select knob to confirm the setting.

## Scan Tuning – FM

1. Press the Power button to turn on the radio.
2. Select the desired waveband by pressing the Band button. Make sure the soft bended rod antenna has been well placed for best FM reception. Try to avoid operating the radio next to a computer screen and other equipment which will cause interference to the radio.
3. Press the Auto tune button and the radio will search and stop automatically when it finds a radio station. The radio will continue searching for the next available station unless the operator presses the Auto tune button to stop the scanning.
4. Rotate the Volume/Tuning Control/Select knob to get the desired sound level. The LCD display will show sound level changes.

### Note:

In order to use the Volume/Tuning Control/Select knob to find your desired station, press and hold the Volume/Tuning Control/Select knob to switch to the tuning control mode.

5. To turn off the radio, press the Power button.

## FM scan zone

When using FM mode, your radio can be set to scan either local stations or to scan all stations including distant radio stations.

## Manual Tuning – FM

1. Press the Power button to turn on the radio.
2. Press the Band button to select desired waveband. Adjust the antenna as described above.
3. Rotate the Volume/Tuning Control/Select knob will change the frequency in the following increment:  
FM: 50 or 100 kHz

### Note:

In order to use the Volume/Tuning Control/Select knob to find your desired station, press and hold the Volume/Tuning Control/Select knob to switch to the tuning control mode.

4. Keep rotating the Volume/Tuning Control/Select knob until desired frequency is shown on the display.
5. Rotate the Volume/Tuning Control/Select knob to get the desired sound level.
6. To turn off the radio, press the Power button.

## Display modes – FM

Your radio has a range of display options for FM radio mode:

Repeat pressing the Info button to cycle through the different options.

- a. Program station Indicates the name of the station being listened to.
- b. Radio text Indicates text message such as new items, etc.
- c. Program type Indicates the type of station being listened to such as Pop, Classic, News, etc.
- d. Time & date Indicates the current time and date.
- e. Frequency Indicates the frequency of the FM signal.

## Storing stations in preset memories (DAB and FM)

There are 5 memory presets for each waveband.

1. Press the Power button to turn on the radio.
2. Tune to the desired station using one of the methods previously described.
3. Press and hold the desired Preset button until the preset number shown on the display, for example, “P2 Saved”. The station is then stored in the selected Preset button.
4. Repeat this procedure for the remaining presets.
5. Stations stored in the preset memories can be overwritten by following the procedures described above.

## Recall stations from the preset memories (DAB and FM)

1. Press the Power button to turn on the radio.
2. Press the Band button to select your desired waveband.

3. Press the desired Preset button momentarily. The preset number and station frequency will appear in the display.

## Brightness control

The backlight of the display can be adjusted.

1. Press the Advanced setting button.
2. Rotate the Volume/Tuning Control/Select knob until "Backlight" shown on the display. Press the Volume/Tuning Control/Select knob to enter the setting.
3. Rotate the Volume/Tuning Control/Select knob to choose to enable or disable the backlight function, then press the Volume/Tuning Control/Select knob to confirm the setting.

## System reset

If your radio fails to work correctly, or some digits on the display are missing or incomplete, carry out the following procedure.

1. Press the Advanced setting button.
2. Rotate the Volume/Tuning Control/Select knob until "Factory Reset" shown on the display. Press the Volume/Tuning Control/Select knob to enter the setting.
3. Rotate the Volume/Tuning Control/Select knob to choose "Yes". Press the Volume/Tuning Control/Select knob to confirm the setting and a full reset will be performed.

## Software version

1. Press the Advanced setting button.
2. Rotate the Volume/Tuning Control/Select knob until "SW Version" shown on the display. Press the Volume/Tuning Control/Select knob to view the software version installed in the radio.

## Micro USB port for software upgrade

Software updates for your radio may be available in the future.

As software updates become available software and information on how to update your radio can be found at Makita website.

## How to play other audios

### CAUTION:

Unplug this apparatus before connecting other audios.

- There are 2 AUX IN sockets. AUX IN 1 is located on the front panel, and AUX IN 2 is located in the battery compartment.
- Connect a stereo or mono source (i.e. iPod, MP3, or CD player) to either AUX IN 1 or AUX IN 2 by audio cord.
- Repeatedly press and release the Band button until "AU1" or "AU2" is displayed, then AUX function is activated.

## SPECIFICATIONS

### Power requirements

AC power adaptor	DC 12 V 1A, center pin positive
Battery	Cluster battery: 7.2 V - 10.8 V Slide battery: 10.8 V - 18 V
Frequency coverage	FM 87.50 - 108 MHz DAB 174.928 - 239.200 MHz
DAB Channel block	DAB (Band III) 5A-13F
Compatible standard	DAB

### Circuit feature

Loudspeaker	3 inches 8 ohm
Output power	7.2 V: 0.5 W X 2 10.8 V: 1.2 W X 2 14.4 V: 2.2 W X 2 18 V: 3.5 W X 2
Input terminal	3.5 mm dia. (AUX IN1/AUX IN2)
Antenna system	DAB/FM: soft bended rod antenna
Dimension (L x W x H) in mm	280 x 163 x 302
Weight	4.0 kg (without battery)

## MAINTENANCE

### CAUTION:

- Never use gasoline, benzine, thinner, alcohol or the like. Discoloration, deformation or cracks may result.



**Makita Europe N.V.** Jan-Baptist Vinkstraat 2,  
3070 Kortenberg, Belgium

**Makita Corporation** 3-11-8, Sumiyoshi-cho,  
Anjo, Aichi 446-8502 Japan