



Fitting Instructions for Metal Drawer System

1. The product has left and right assembly, which are marked according to their location:

CL – Cabinet Left Runner	CR – Cabinet Right Runner
DL – Drawer Left Metal Box	DR – Drawer Right Metal Box

2. These drawer runners are only suitable for use with drawers with a height of 81mm.

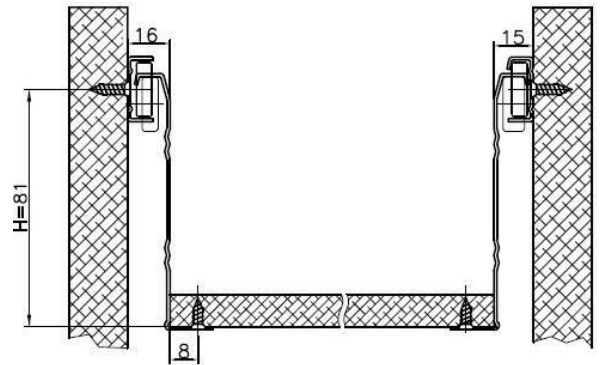

3. Place the drawer on its side, with the left side facing up. Place the metal box marked, "DL" on the side of the drawer – silver metal edge of "DL" must sit flush with front of the drawer and the angled section should wrap around the back of the drawer. The wheels should be towards the back of the drawer.



4. Insert 2 of the supplied screws at the bottom of the drawer and 2 at the rear.
5. Select the metal box marked "DR" & repeat on the other side of the cabinet.





6. On the inside of your cabinet, mark the location of the position of your side runners – these should be level with the bottom of the drawer and should be positioned so that there will be 3mm gap between the drawers.



7. Selecting the runner marked DL and using the mark made in step 6, fit the runner to the inside of the cabinet so that the wheel is positioned as per the diagram below.

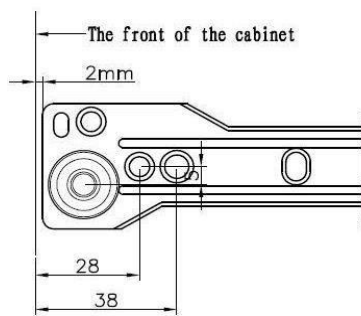

8. Along the length of the runner, there are 2 oval holes. Place the runner along at the marked position and insert 2 screws through the oval holes.



9. Repeat the same process on right hand side with DR runner.
10. Insert the drawer by tipping into side runners.