

TITAN

1500W Table Saw

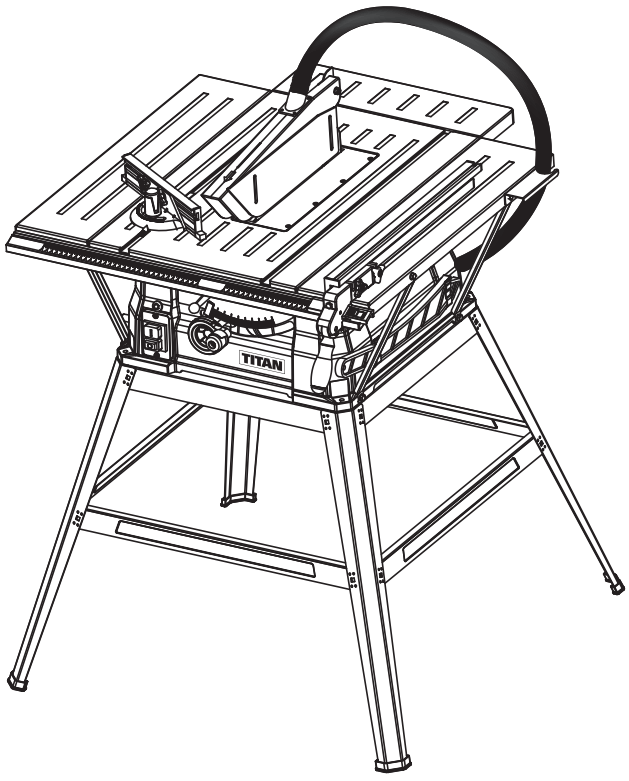

TTB674TAS

Barcode: 5052931563654



WARNING! Read the instructions before using the product!

TITAN

Congratulations on your purchase of a TITAN power tool from TITAN Power Tools (UK) Ltd. We want you to continue getting the best performance from it so this handbook includes information on safety, handling and care. Please retain this handbook in case you need to refer to any of the information in the future. Your TITAN power tool comes with a 2 year guarantee, so should it develop a fault within this period contact your retailer.

GUARANTEE



This TITAN product carries a 2 year guarantee. If your product develops a fault within this period, you should, in the first instance contact the retailer where the item was purchased.

This guarantee specifically excludes losses caused due to:

- Fair wear and tear
- Misuse or abuse
- Lack of routine maintenance
- Failure of consumable items (such as batteries)
- Accidental damage
- Cosmetic damage
- Failure to follow manufacturer's guidelines
- Loss of use of the goods

This guarantee does not affect your statutory rights. This guarantee is only valid in the UK.

Let's get started...

These instructions are for your safety. Please read through them thoroughly before use and retain them for future reference.



Getting **started**... 04

Your product	05
Technical and legal information	07
Before you start	15



In more **detail**... 33

Product functions	34
Care and maintenance	50
Recycling and disposal	56
Trouble shooting	57
EC declaration of conformity	59

Your product

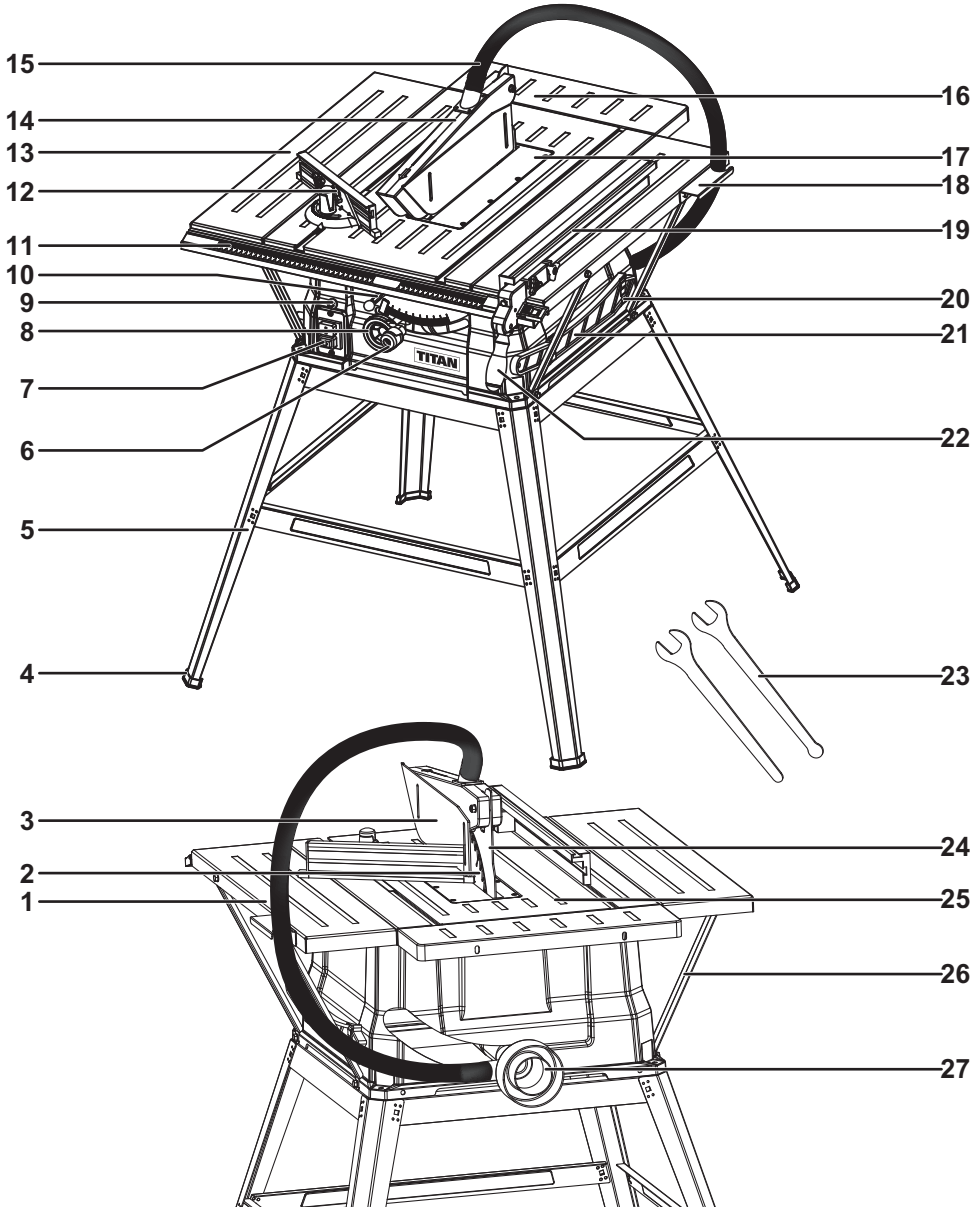

Getting started....

1. Right extension table
2. Saw blade
3. Blade guard apron
4. Rubber foot
5. Stand
6. Height adjusting handle
7. On/Off switch
8. Bevel adjusting handwheel
9. Overload reset switch
10. Bevel locking handle
11. Front rail
12. Mitre gauge
13. Left extension table
14. Blade guard
15. Dust extraction hose
16. Rear extension table
17. Table insert
18. Hose hold
19. Rip fence
20. Push stick hold
21. Push stick
22. Rip fence locking handle
23. Blade wrench
24. Riving knife
25. Working table
26. Supporting bar
27. Dust extraction adapter

Safety devices

Blade guard [14] and blade guard apron [3]

Protects against accidental touching of the saw blade and flying chips. The blade guard and blade guard apron must always be mounted during operation.

Riving knife [24]

Prevents a work piece from being caught by the ascending teeth and being flung against the operator. The riving knife must be mounted during operation.

Push stick [21]

Serves as an extension of the operator's hand and protects against accidental touching of the saw blade. The push stick must always be used if the distance between the rip fence and saw blade is less than 12 cm.

Technical specifications

General

> Input Voltage	: 230-240V~50Hz
> Power Input	: 1500W
> No Load Speed	: 4500min ⁻¹
> Degree of Protection	: IP20
> Blade Size	: ø254mm × ø30mm × 2.8mm 40T
> Main Table Size	: 430 × 638mm
> Extension Table Size (left/right)	: 638 × 150mm
> Extension Table Size (rear)	: 430 × 120mm
> Blade Tilting Range	: 0°~45°
> Max. Cutting Capacity	: 80mm (90°) / 55mm (45°)
> Net Weight	: 25.4kg

NOISE

A weighted sound pressure L_{pA}96.38dB(A)

A weighted sound pressure L_{WA}109.38dB(A)

Uncertainty.....3dB(A)

The sound intensity level for the operator may exceed 85dB(A) and sound protection measures are necessary.

Important note

Remove the mains plug from socket before carrying out any adjustment or servicing.

Ensure your mains supply voltage is the same as your tool rating plate voltage.

Symbols

On the product, the rating label and within these instructions you will find among others the following symbols and abbreviations.

Familiarise yourself with them to reduce hazards like personal injuries and damage to property.

V~	Volt	Hz	Hertz
W	Input power	kg	Kilogram
min ⁻¹	Per minute	dB(A)	Decibel (A-rated)

yyWxx: Manufacturing date code; year of manufacturing (20yy) and week of manufacturing (Wxx);



Caution / Warning.



Wear hearing protection.



Read the instruction manual.



Wear eye protection.



wear protective gloves when handling saw blades and rough workpieces.



Wear respiratory protection.



Class II construction.



For woodwork only.



Pay attention to your hands and other parts of your body when working with and on the saw.



Switch the product off and disconnect it from the power supply before assembly, cleaning, adjustments, maintenance, storage and transportation.



The product complies with the applicable European directives and an evaluation method of conformity for these directives was done.



WEEE symbol. Waste electrical products should not be disposed of with household waste. Please recycle where facilities exist.

Check with your Local Authority or local store for recycling advice.

Safety warnings

GENERAL SAFETY INSTRUCTIONS



WARNING! To ensure safe operation when using your Table Saw, make sure you follow basic safety principles to reduce risk of personal injury, electric shock and fire. Please read the following instructions prior to operating this product and keep for future use.

SAVE THESE INSTRUCTIONS

1. Keep the work area clean.

> Cluttered and dark areas invite accidents.

2. Consider work area environment.

> Do not expose power tools to rain. Do not use power tools in damp or

wet locations. Keep the work area well lit. Do not use tools in the presence of flammable liquids or gases.

3. Guard against electric shock.

> Avoid body contact with earthed or grounded surfaces (e.g. pipes, radiators, ranges, refrigerators).

4. Keep children away.

> Do not let persons, especially children, not involved in the work touch the tool or the extension cord and keep them away from the work area.

5. Store idle tools.

> When not in use, tools should be stored in a dry, high or locked up place, out of reach of children.

6. Do not force the tool.

> It will do the job better and safer at the rate for which it was intended.

7. Use the right tool.

> Do not force small tools to do the job of a heavy-duty tool. Do not use tools for purposes not intended, for example, do not use circular saws to cut tree limbs or logs.

8. Dress properly.

> Do not wear loose clothing or jewellery, they can be caught in moving parts. Non-skid footwear are recommended when working outdoors. Wear protective hair covering to contain long hair.

9. Use protective equipment.

> Use safety glasses. Use face or dust mask if working operations create dust.

10. Connect dust extraction equipment.

> If the tool is provided for the connection of dust extraction and collecting equipment, ensure these are connected and properly used.

11. Do not abuse the cord.

> Never yank the tool to disconnect it from the socket. Keep the cord away from heat, oil and sharp edges.

12. Secure work.

> Where possible use clamps or a vice to hold the work. It is safer than using your hand.

13. Do not overreach.

> Keep proper footing and balance at all times.

14. Maintain tool with care.

> Keep cutting tools sharp and clean for better and safer performance. Follow instructions for lubrication and changing accessories. Inspect tool cord periodically and if damaged have them replaced by an authorised service facility. Inspect extension cords periodically and replace if damaged. Keep handles dry, clean and free of oil or grease.

15. Disconnect tools.

- > When not in use, before servicing and when changing accessories such as blades, bits and cutters, disconnect tools from the power supply.

16. Remove adjusting keys and wrenches.

- > From the habit of checking to see that keys and adjusting wrenches are removed from the tool before turning it on.

17. Avoid unintentional starting.

- > Ensure switch is in the "off" when plugging in.

18. Use outdoor extension leads.

- > When tool is used outdoors, use only extension cords intended for outdoor use and so marked.

19. Stay alert.

- > Watch what you are doing. Use common sense. Do not operate tool when you are tired.

20. Check damaged parts.

- > Before further use of the tool, it should be carefully checked to determine that it will operate properly and perform its intended function. Check for alignment of moving parts, binding of moving parts, breakage of parts, mounting and any other conditions that may affect its operation. A guard or other part that is damaged should be properly repaired or replaced by an authorised service centre unless otherwise indicated in this instruction manual. Have defective switches replaced by an authorised service facility. Do not use the tool if the switch dose not turn it on and off.

21. Warning.

- > The using of any accessory or attachment other than those recommended in this instruction manual may present a risk of personal injury.

22. Have your tools repaired by qualified person.

- > This electrical tool complies with the relevant safety requirements. Repairs should only be carried out by qualified persons using original spare parts, otherwise this may result in considerable danger to the user.

HEALTH ADVICE

Warning! When drilling, sanding, sawing or grinding, dust particles will be produced. In some instances, depending on the materials you are working with, this dust can be particularly harmful to you (e.g. lead from old gloss paint). You are advised to consider the risks associated with the materials you are working with and to reduce the risk of exposure. You should:

- Work in a well-ventilated area.
- Work with approved safety equipment, such as those dust masks that are specially designed to filter microscopic particles.

ADDITIONAL SAFETY INSTRUCTIONS FOR YOUR TABLE SAW

- > Wear eye protection.
- > Do not use the tool in presence of flammable liquids or gases.
- > **NEVER** use the tool with an abrasive cut-off wheel installed.
- > Check the blade carefully for cracks or damage before operation. Replace cracked or damaged blade immediately.
- > Use only saw blades recommended by the manufacturer and which conform to EN847-1, and observe that the riving knife must not be thicker than the width of the cut by the saw blade and not thinner than the body of the blade.
- > Always use accessories recommended in this manual. Use of improper accessories such as abrasive cut-off wheels may cause an injury.
- > Select the correct saw blade for the material to be cut.
- > Do not use saw blades manufactured from high speed steel.
- > To reduce the emitted noise, always be sure that the blade is sharp and clean.
- > Use correctly sharpened saw blades. Observe the maximum speed marked on the saw blade.
- > Clean the spindle, flanges (especially the installing surface) and hex nut before installing the blade. Poor installation may cause vibration/wobbling or slippage of the blade.
- > Use saw-blade guard and riving knife for every operation for which it can be used, including all through sawing operations. Always install the blade guard following the instructions out-lined in this manual. Through sawing operations are those in which the blade cuts completely through the work piece as in ripping or cross cutting. **NEVER** use the tool with a faulty blade guard or secure the blade guard with a rope, string, etc. Any irregular operation of the blade guard should be corrected immediately.
- > Immediately reattach the guard and riving knife after completing an operation which requires removal of the guard.
- > Do not cut metal objects such as nails and screws. Inspect for and remove all nails, screws and other foreign material from the work piece before operation.
- > Remove wrenches, cut-off pieces, etc. from the table before the switch is turned on.
- > Wear protective gloves when handling saw blades and rough workpieces.
- > Keep hands out of the line of the saw blade.
- > **NEVER** stand or permit anyone else to stand in line with the path of the saw blade.
- > Make sure the blade is not contacting the riving knife or work piece before the switch is turned on.

- > Before using the tool on an actual work piece, let it run for a while. Watch for vibration or wobbling that could indicate poor installation or a poorly balanced blade.
- > The tool should not be used for slotting, rabbetting or grooving.
- > Replace table insert when worn.
- > **NEVER** make any adjustments while tool is running. Disconnect tool before making any adjustments.
- > Use a push stick when required. Push sticks **MUST** be used for ripping narrow work pieces to keep your hands and fingers well away from the blade.
- > Always store the push-stick when it is not in use.
- > Pay particular attention to instructions for reducing risk of **KICKBACK**. **KICKBACK** is a sudden reaction to a pinched, bound or misaligned saw blade. **KICKBACK** causes the ejection of the work piece from the tool back towards the operator. **KICKBACKS CAN LEAD TO SERIOUS PERSONAL INJURY**. Avoid **KICKBACKS** by keeping the blade sharp, by keeping the rip fence parallel to the blade, by keeping the riving knife and blade guard in place and operating properly, by not releasing the work piece until you have pushed it all the way past the blade, and by not ripping a work piece that is twisted or warped or does not have a straight edge to guide along the fence.
- > Do not perform any operation freehand. Freehand means using your hands to support or guide the work piece, in lieu of a rip fence or mitre gauge.
- > **NEVER** reach around or over saw blade. **NEVER** reach for a work piece until the saw blade has completely stopped.
- > Avoid abrupt, fast feeding. Feed as slowly as possible when cutting hard work pieces. Do not bend or twist work piece while feeding. If you stall or jam the blade in the work piece, turn the tool off immediately. Unplug the tool. Then clear the jam.
- > **NEVER** remove cut-off pieces near the blade or touch the blade guard while the blade is running.
- > Knock out any loose knots from work piece **BEFORE** beginning to cut.
- > Do not abuse cord. Never yank cord to disconnect it from the receptacle. Keep cord away from heat, oil, water and sharp edges.
- > When using the tool indoors, always connect the tool to an external dust extraction system. Switched on the dust extraction system before starting the tool.
- > The guard can be lifted during work piece setup and for ease of cleaning. Always make sure that guard hood is down and flat against sawtable before plugging in the tool.
- > Wear gloves against the hazard of cutting when handling saw blades, feeding wood into the tool or doing maintenance.

- > Never try to remove chips while the saw blade is running or the tool is switched on.
- > Never try to use the tool unless all guards and other safety devices necessary for tool are in good working order.
- > Operators must be adequately trained in the assembly, adjustment and operation of the tool.
- > Never use the blades which maximum speed is lower than the no load speed of the tool.
- > Keep work area well lit.

REDUCING RISK OF KICKBACK

- > Always use the correct blade depth setting. The top of the blade teeth should clear the work piece by 1/8" (3.2 mm) to 1/4" (6.4 mm).
- > Inspect the work piece for knots or nails before beginning a cut. Knock out any loose knots with a hammer. Never saw into a loose knot or nail.
- > Always use the rip fence when rip cutting and the mitre gauge when crosscutting. This helps to prevent twisting the wood in the cut.
- > Always use clean, sharp, and properly set blades. Never make cuts with dull blades.
- > To avoid pinching the blade, support the work properly before beginning a cut.
- > When making a cut, use steady, even pressure. Never force cuts.
- > Do not cut wet or warped lumber.
- > Always hold the work piece firmly with both hands or with push sticks. Keep your body in a balanced position to be ready to resist kickback should it occur. Never stand directly in line with the blade.
- > Use the right type of blade for the cut being made.

VIBRATION

The European Physical Agents (Vibration) Directive has been brought in to help reduce hand arm vibration syndrome injuries to power tool users. The directive requires power tool manufacturers and suppliers to provide indicative vibration test results to enable users to make informed decisions as to the period of time a power tool can be used safely on a daily basis and the choice of tool. Further Advice can be found at www.hse.gov.uk

Vibration total values (triax vector sum) determined according to EN61029:	
Work mode description 1 (if required by the relevant Part 2)	Vibration emission value $a_n = 3.0\text{m/s}^2$
	Uncertainty $K = 1.5\text{m/s}^2$

The declared vibration emission value should be used as a minimum level and should be used with the current guidance on vibration.

Calculating the actual period of the actual period off use can be difficult and the HSE website has further information.

The declared vibration emission been measured in accordance with a standardised test stated above and may be used to compare one tool with another.

The declared vibration emission value may also be used in a preliminary assessment of exposure.



Warning! The vibration emission value during actual use of the power tool can differ from the declared value depending on the ways in which the tool is used dependant on the following examples and other variations on how the tool is used:-

How the tool is used and the materials being cut or drilled.

The tool being in good condition and well maintained.

The use the correct accessory for the tool and ensuring it is sharp and in good condition.

The tightness of the grip on the handles.

And the tool is being used as intended by its design and these instructions.

This tool may cause hand-arm vibration syndrome if its use is not adequately managed



Warning! identify safety measures to protect the operator that are based on an estimation of exposure in the actual conditions of use (taking account of all parts of the operating cycle such as the times when the tool is switched off and when it is running idle in addition to the trigger time). Note the use of other tools will reduce the users' total working period on this tool.

Helping to minimise your vibration exposure risk.

ALWAYS use sharp chisels, drills and blades.

Maintain this tool in accordance with these instructions and keep well lubricated (where appropriate).

Avoid using tools in temperatures of 10°C or less.

Plan your work schedule to spread any high vibration tool use across a number of days.

Health Surveillance

All employees should be part of an employer's health surveillance scheme to help identify any vibration related diseases at an early stage, prevent disease progression and help employees stay in work.

Intended use

When used for its intended purpose, this device corresponds to the state of the art, as well as to the current safety requirements at the time of its introduction.

The device is intended for longitudinal and cross-cutting of solid wood, coated wood, chip board, block board and similar woodlike materials. Round work pieces may not be sawed since they can be twisted by the rotating saw blade.

Only materials may be processed for which the corresponding saw blade is approved. The product must not be used for sawing firewood.

Only saw blades suitable for the device (HM saw blades) may be used. The use of HSS saw blades and cut-off wheels of any type is forbidden.

The device is not suitable for commercial or industrial use.

Any other type of use is inappropriate. Improper use or modifications to the device or the use of components that are not tested and approved by the manufacturer may result in unforeseen damage!

Any use that deviates from its intended use and is not included in these instructions is considered unauthorised use and relieves the manufacturer from his or her legal liability.



WARNING: Before using your table saw, read the instruction manual carefully.



WARNING: Carefully remove the table saw from the carton and remove the protective foam from around the motor.



WARNING: Risk of injury!

Do not connect to the power supply before assembly, adjustment and maintenance.

Unpack

- > Unpack all parts and lay them on a flat, stable surface.
- > Remove all packing materials and shipping devices if applicable.
- > Make sure the delivery contents are complete and free of any damage. If you find that parts are missing or show damage do not use the product but contact your dealer. Using an incomplete or damaged product represents a hazard to

people and property.

> Ensure that you have all the accessories and tools needed for assembly and operation. This also includes suitable personal protective equipment.

The following items are included with your Table Saw:

For table saw:

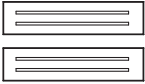

Left & right extension table
[13,1] x 02



Front rail
[11] x 01

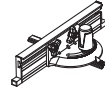

Mitre gauge
[12] x 01

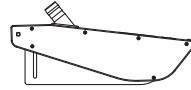

Blade guard
[14] x 01



Dust extraction hose
[15] x 01



Rear extension table
[16] x 01

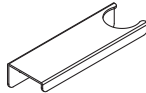

Hose hold
[18] x 01



Rip fence
[19] x 01



Push stick hold
[20] x 02



Push stick
[21] x 01

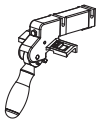

Rip fence locking handle
[22] x 01



Blade wrench
[23] x 02



Riving knife assembly
[24] x 01



Supporting bar
[26] x 04

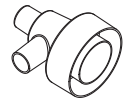

Dust extraction adapter
[27] x 01

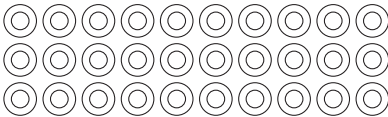

Flat washer 6
[28] x 30

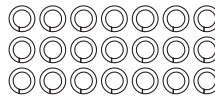

Spring washer 6
[29] x 21

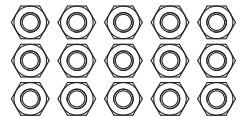

Hex nuts M6
[30] x 15

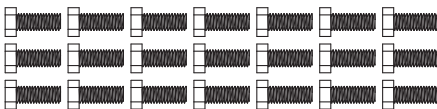

Hex bolts M6 x 16
[31] x 21

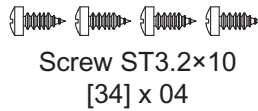
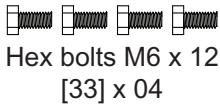
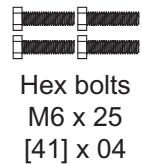
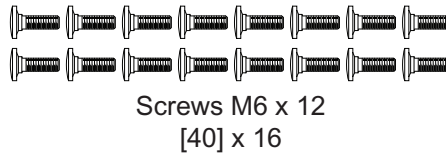
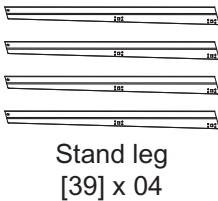
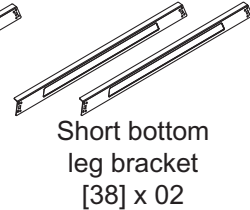
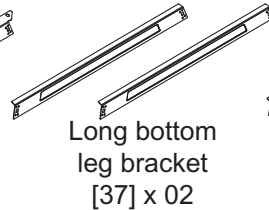
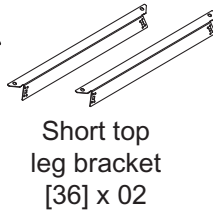
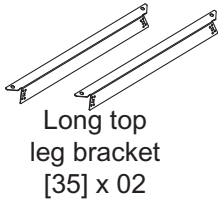
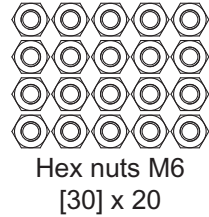
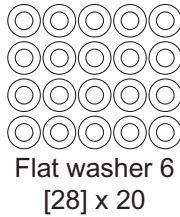
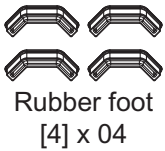

Rear extension pole
[32] x 02

**For stand:****You will need**

(items not supplied)

- > Suitable personal protective equipment
- > Phillips screwdriver
- > 10mm Wrench or adjustment wrench
- > 5mm Hex key
- > Square
- > Triangle square

(items supplied)

- > Blade wrench (2 pcs)

**WARNING: Risk of injury!**

Always pull out the mains plug (disconnect the product from its power supply) before commencing work on the product.

To assemble the left & right extension tables

- > Place cardboard or an old blanket on floor in order to protect the surface of the working table.
- > Carefully remove the table saw assembly from the carton and remove the protective polyfoam from around the motor.
- > Place the table saw assembly upside down on the protective material.
- > Attached the left/right extension tables [13, 1] to the working table [25] with washers 6 [28], spring washers 6 [29] and hex bolts M6 x 16 [31].

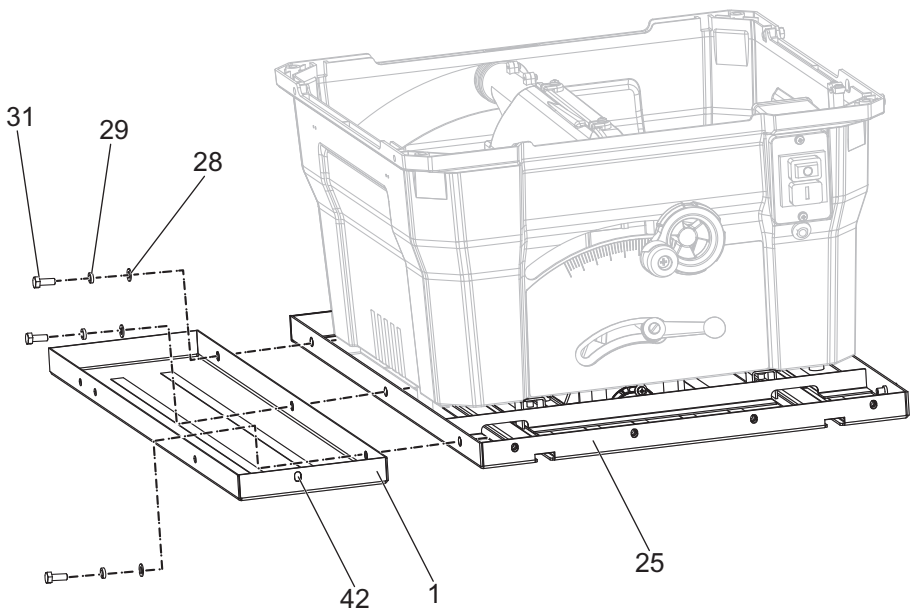

Fig. 1

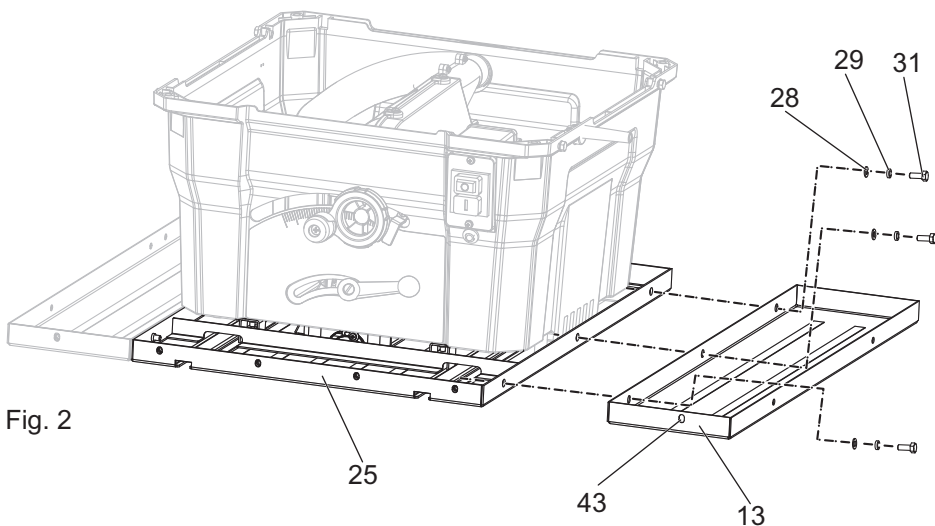

Fig. 2

i **NOTE:** Only one hole [42,43] on the side of the extension tables must be in the front after finished.

> Attach two supporting bars [26] with the left extension table with flat washers 6 [28], spring washers 6 [29], hex nuts M6 [30] and hex bolts M6 x 16 [31]. Position the other end of bars to cabinet with flat washers 6 [28], hex nuts M6 [30] and hex bolts M6 x 16 [31]. (See Fig. 3)

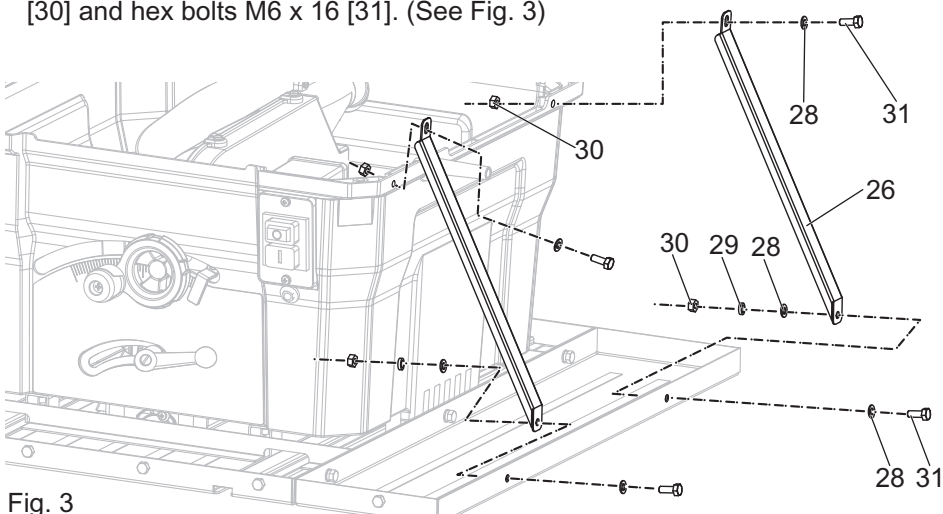

Fig. 3

- > Attach two supporting bars [26] and hose hold [18] with the right extension table with flat washers 6 [28], spring washers 6 [29], hex nuts M6 [30] and hex bolts M6 x 16 [31].

Position the other end of bars to cabinet with flat washers 6 [28], hex nuts M6 [30] and hex bolts M6 x 16 [31]. (See Fig. 4)

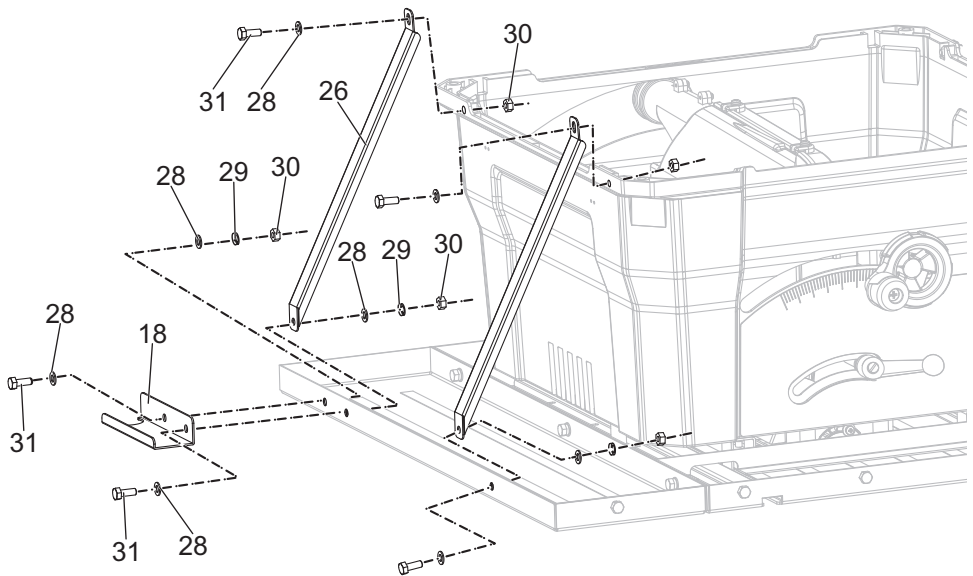

Fig. 4

To assemble the rear extension table

- > Align the holes on rear extension table [16] to the rear extension poles [32] and the working table [25].
- > Position the rear extension table [16] and the rear extension poles [32] with flat washers 6 [28], spring washers 6 [29] and hex bolts M6 x 12 [33].

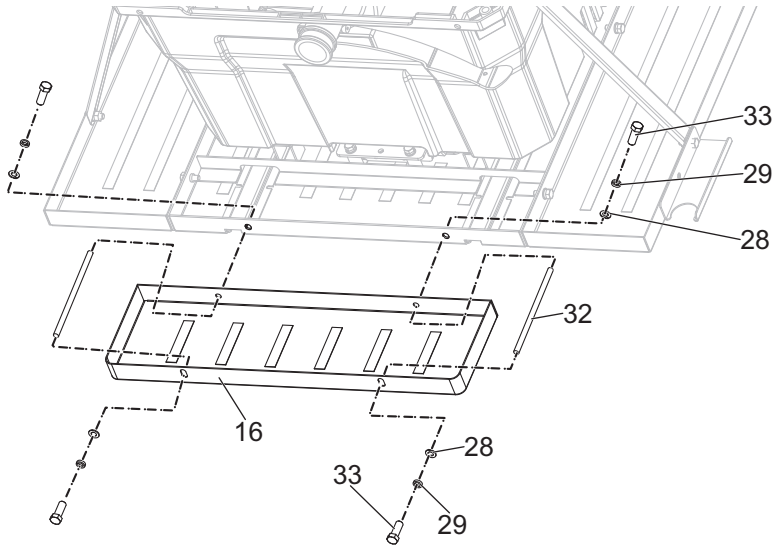

Fig. 5

To assemble the push stick hold

- > Turn the table saw right way up with two person handling.
- > There are push stick holds on the left side of the machine. You can connect the push stick holds [20] with four screws ST3.2 x 10 [34] supplied and you can put the push stick [21] on the holds when you do not use it.

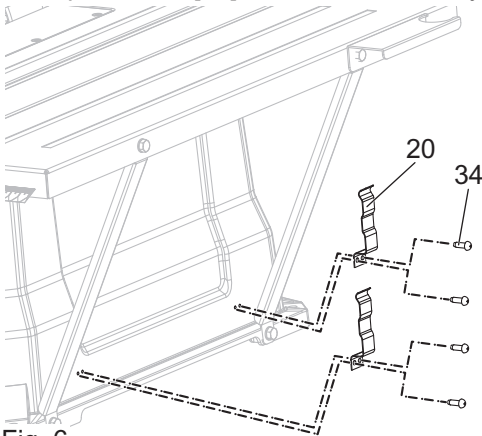

Fig. 6

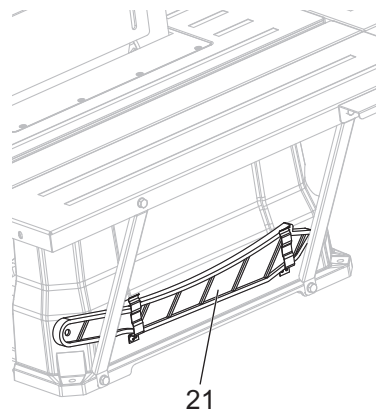

Fig. 7

To assemble the riving knife

- > Loosen the eight cross-screws [44] with the screwdriver and remove the table insert [17]. (Fig. 8)

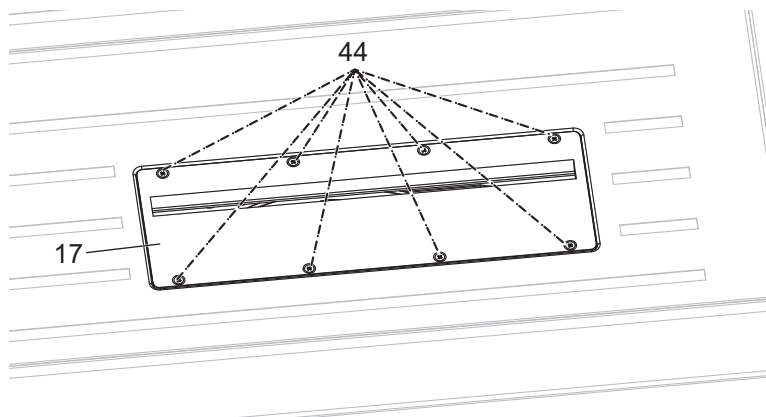

Fig. 8

- > Loosen the hex nut M6 [45] on the riving knife [24], remove the screw M6 x 45 [46], flat washer 6 [47] and hex nut M6 [45].

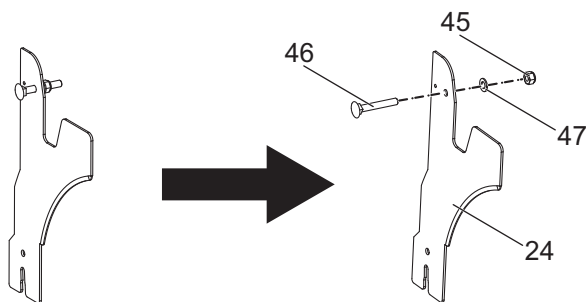

Fig. 9

- > Loosen the blade bevel locking handle [10] and tilt the bevel adjusting handwheel [8] to 90° and turn height adjusting handle [6] to raise the blade to its highest position. Tighten the blade bevel locking handle [10]. (Refer to the sections “bevel locking handle”, “bevel adjusting handwheel” and “height adjusting handle” on Page 35-37).
- > Loosen the tri-wing knob [48] and pull the flat washer and large square washer [49a] away from the side of the machine.
- > Insert the riving knife [24] to the left of the tri-wing nut and both washers (see Fig.11a). Then push the riving knife down, when you hear a “click” the pin [49] is locked into the hole on the riving knife [24].
- > Push the square washer [49a] onto the pin [49] and then tighten the tri-wing knob [48]. No further adjustment to the riving knife is required.
- > Reinstall the table insert [17].

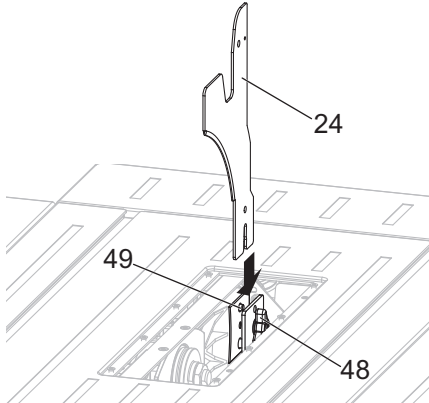

Fig. 10

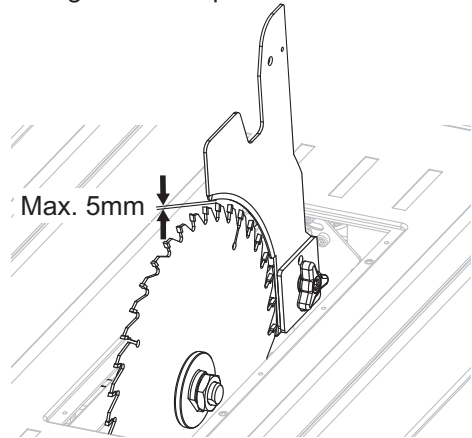

Fig. 11

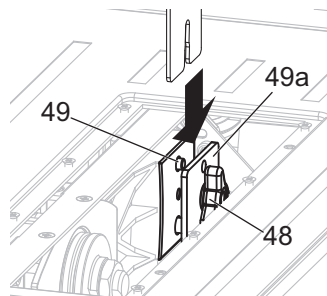

Fig. 11a



NOTE: The riving knife must be aligned with saw blade after finished and the distance between the outside edge of the saw blade and the riving knife must be not more than five millimetres. If not, please contact with your dealer, because riving knife of this table saw not need be adjusted.

To assemble the front rail & rip fence

- > Insert the hex bolts M6 x 16 [31] through the holes on the working table, left and right extension tables, then put the flat washers 6 [28], spring washers 6 [29] and loosely tighten on the hex nuts M6 [30] as shown in the Fig. 12.

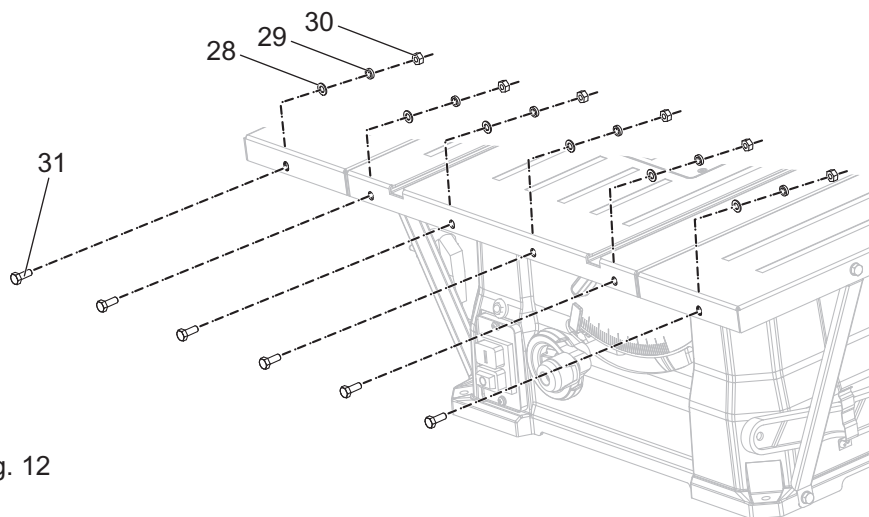

Fig. 12

- > Push on the front guide rail [11] with slot of the front guide rail aligned with the six hex nuts M6 [30] as shown in the Fig. 13.

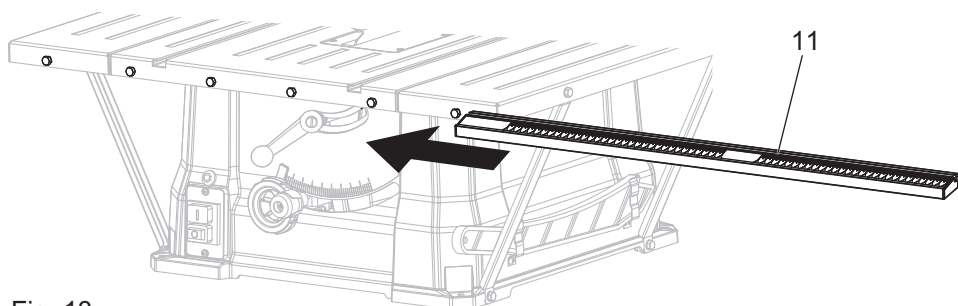

Fig. 13

- > Tighten the rip fence locking handle [22] on the rip fence [19] with the knurled screws [50]. Rip fence locking handle [22] can be mounted on left or right of the rip fence [19] as shown in Fig. 14.

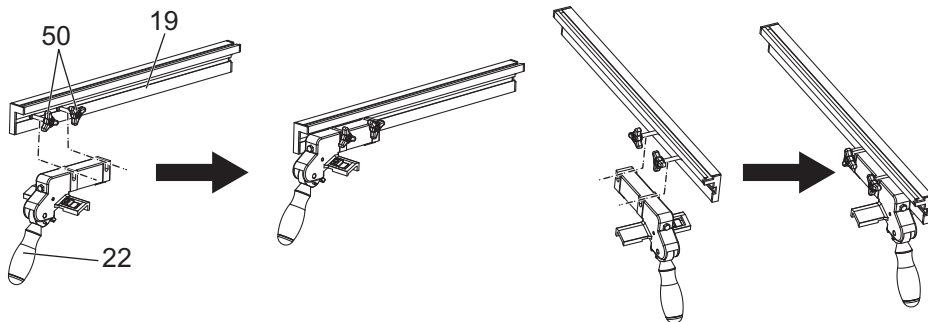

Fig. 14

- > Push the rip fence [19] completely to the saw blade and hold firmly.
- > Move the front rail [11] in such a way that the red line marking [51] on the inspection window [52] is in the zero position on the scale.

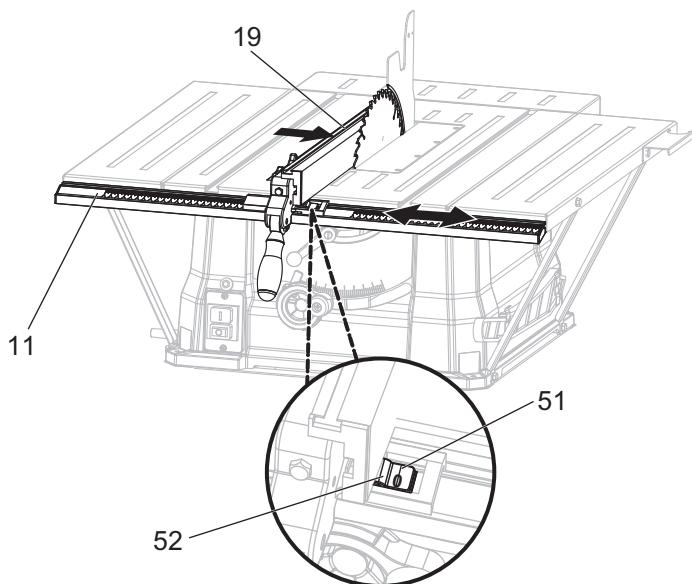

Fig. 15

- > Tighten all the hex nuts M6 [30] of the rails.
- > Loosen the rip fence locking handle [22], place the rip fence on the desired position of the working table, keep the rip fence is level on the working table, then push down the rip fence locking handle [22] in order to lock the rip fence in position.

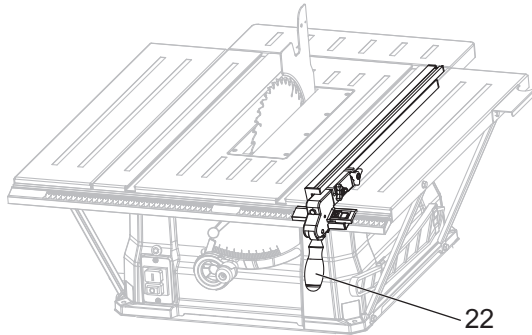

Fig. 16

To assemble the blade guard



WARNING: Risk of injury!

The saw blade guard [14] must be in position at all times to prevent contact with the saw blade. It should lift up and onto the work piece when the work piece is passed through the saw.

- > Attach the blade guard [14] over the riving knife so that the holes in the blade guard [14] and riving knife are aligned.
- > Insert the screw M6 x45 [46] and fit the flat washer 6 [47] and hex nut M6 [45].
- > Tighten the hex nut M6 [45] sufficiently so that the blade guard rests on the table top but will lift when the work piece is pushed into the table.
- > Blade guard MUST be in place.



WARNING: The blade guard should return to its rest position after the work piece has been cut.

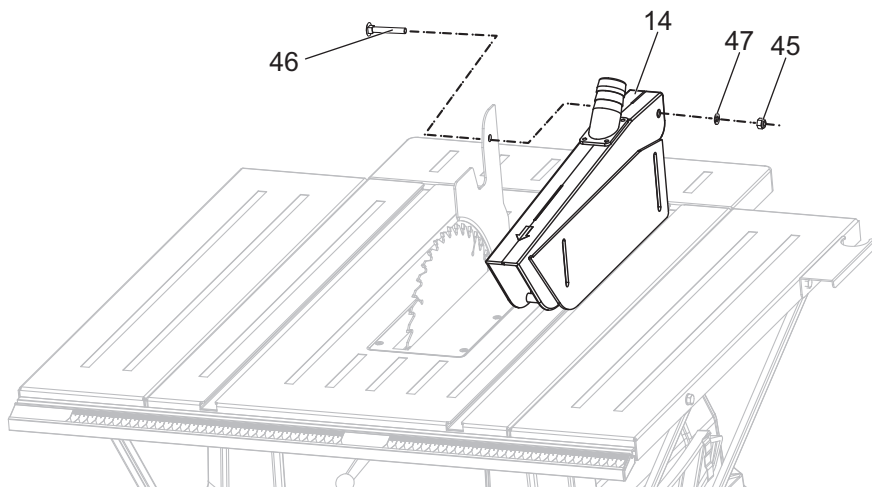

Fig. 17

To attach the mitre gauge

- > Push the guide rail [53] of the mitre gauge [12] into one of the guide grooves of the working table intended for this purpose.

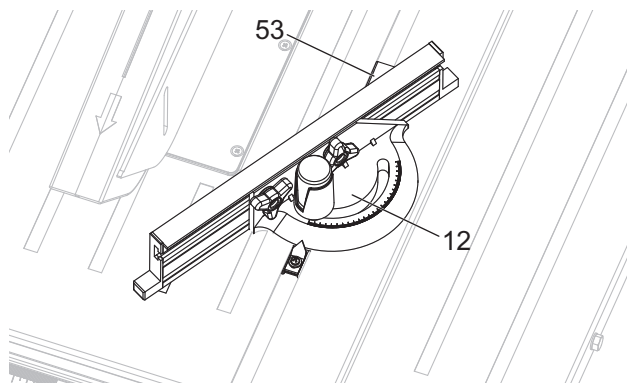

Fig. 18

To assemble the stand



NOTE: The table saw can now be operated firmly mounted on a workbench.

- > Bolt the long & short top leg brackets [35, 36] and long & short bottom leg brackets [37, 38] to the stand legs [39] using screws M6 x 12 [40], flat washers 6 [28], spring washers 6 [29] and hex nuts M6 [30]. Only hand-tighten the hex nuts for the time being.

Important: There are two different sizes of parts 35, 36, 37, 38 these must be assembled opposite each other. For example part 35 must be above part 37.

- > Tighten all bolted connections.
- > Push the rubber foot [4] onto the stand legs [39].

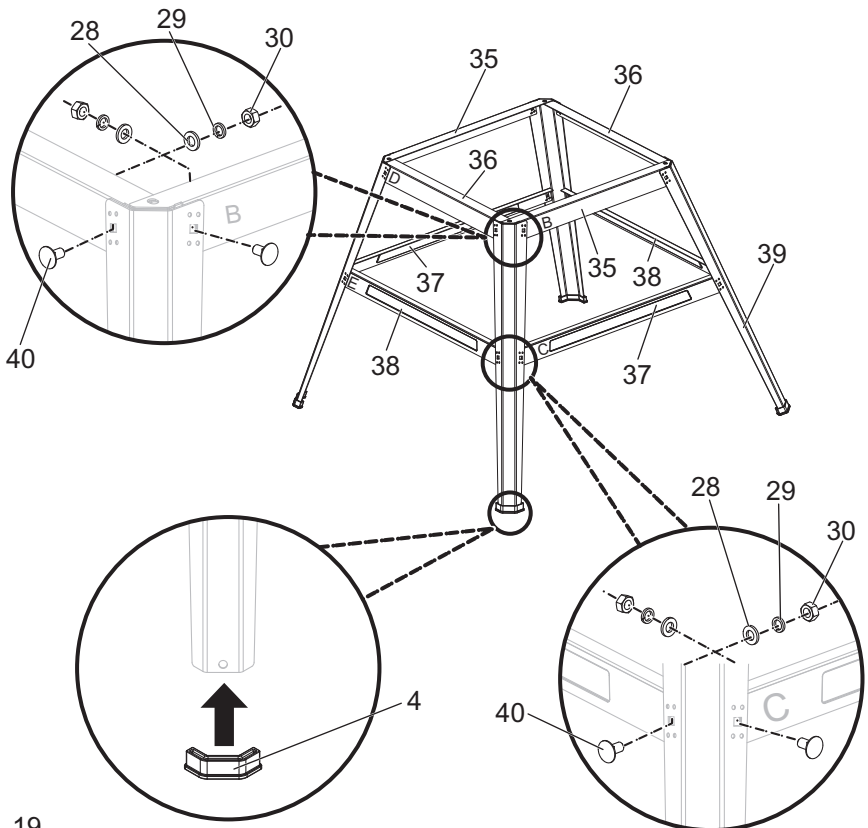

Fig. 19

Attach the table saw to the stand

- > Place the stand on a flat surface.
- > Place the table saw on top of the stand, aligning the holes in the base with the holes in the stand.
- Make sure that** the front of the table saw positioned on the long side.
- > Insert four hex bolts M6 x 25 [41] along with flat washers 6 [28] into the aligned holes.
- > Tighten all four hex nuts M6 [30] and hex bolts [41].



NOTE: Do not over-tighten the bolts that hold the saw to the stand. Doing so will damage the saw base.

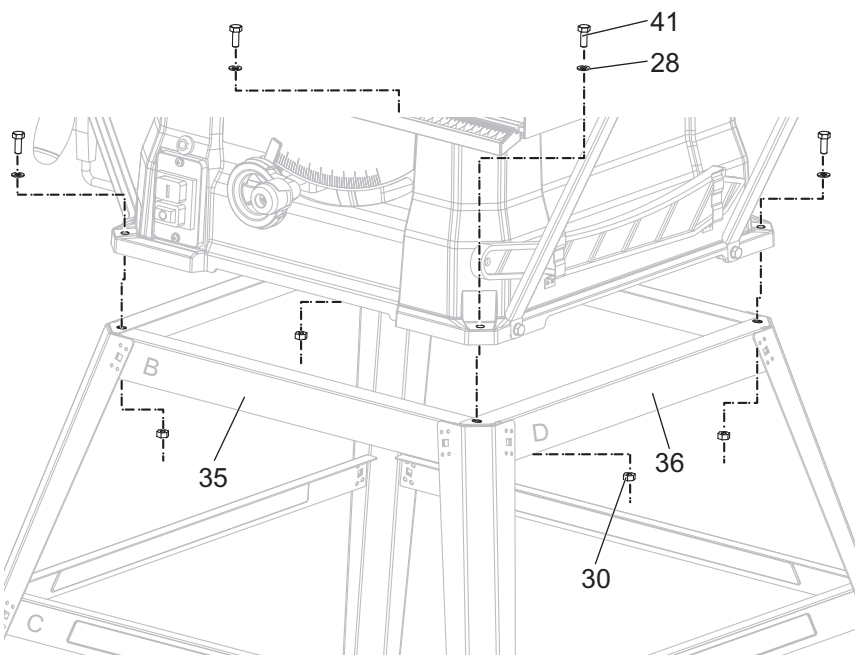

Fig. 20

To mount the table saw onto the workbench

If the stand is not used, the table saw must be properly secured to a sturdy workbench using the four mounting holes on the saw base.

- > Place the table saw over the workbench tabletop and mark four locations on top of the workbench by setting the mounting holes at the saw base.
- > Drill four mounting holes at the marked location of the workbench.
- > Place the table saw on the workbench and align the mounting holes of the table saw with the drilled holes in the workbench.
- > Firmly screw the table saw to the bench surface.

Carefully check the workbench after mounting to make sure that no movement can occur during use. If any tipping, sliding, or walking is noted, secure the workbench to the floor before operating.



Warning: Dust extraction must be fitted and the table saw must regularly check for dust build up and cleaned frequently, otherwise there is a risk of heat built up and potential fire.

To attach the dust extraction adapter and dust extraction hose

- > Attach the side A [54] dust extraction adapter [27] to the dust extraction port [55] on the rear of the table saw as shown in the Fig. 21.

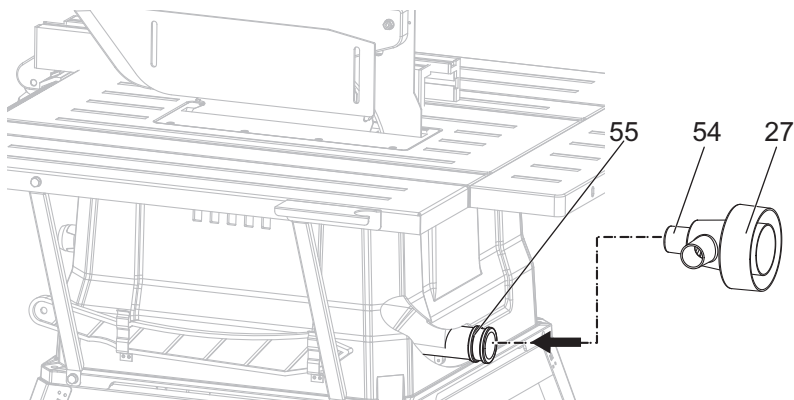

Fig. 21

- > Attach the dust extraction hose [15] to the dust ports [56] on the blade guard and the side B [57] dust extraction adapter [27] as shown in the Fig. 22.

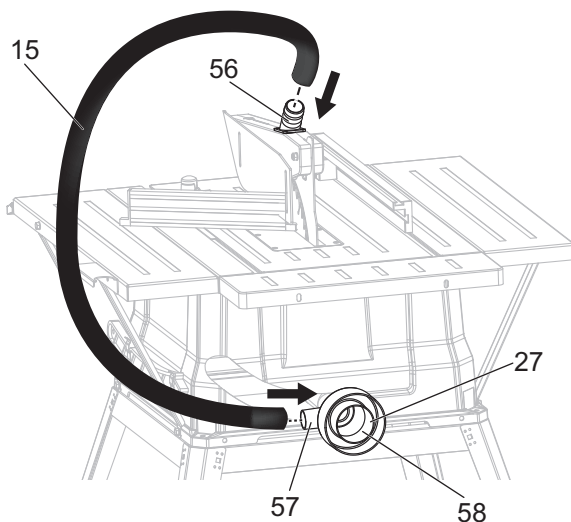

Fig. 22

- > For the work piece passed successfully, to fix the dust extraction hose [15] in the slot of the hose hold [18] before sawing.

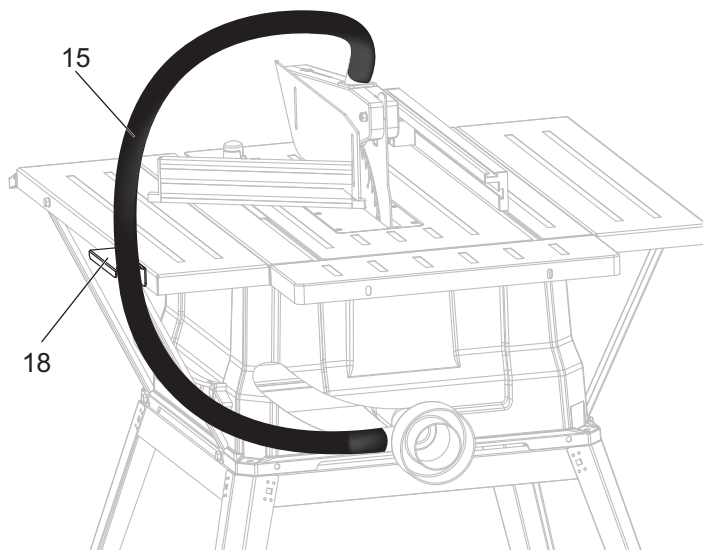

Fig. 23

- > To prevent sawdust buildup, for best result, attach a vacuum hose (not included) to the side C [58] of the dust extraction adapter [27] (See Fig. 22). DO NOT operate the saw with hose in place unless the vacuum is turned on.

Check before starting!



Warning: Risk of injury!

In case of malfunctions, press the red 0-Button on the On/Off switch [7] and pull out the mains plug.



Warning: Risk of injury!

The table saw must only be put into operation if no faults are found. If a part is defective, it must absolutely be replaced before the next use.

Check the safe condition of the product before plugging the power cable:

- > Check whether there are any visible defects.
- > Check whether all parts of the device are firmly attached.
- > Check whether the safety equipment is in faultless condition.
- > Check whether the saw blade can run freely.
- > Check whether the adjusting screw of the tilt setting is tightened.

Connection to the electrical supply

- > Before switching on, make sure that the voltage of the mains supply is the same as indicated on the rating plate. This product is designed to operate on 230-240V~50Hz. Connecting it to any other power source may cause damage.



In more detail...

Product functions	34
Care and maintenance	50
Recycling and disposal	56
Trouble shooting	57
EC declaration of conformity	59

OPERATION CONTROLS

On/Off switch

**Warning: Risk of injury!**

Before turning on the switch make sure the blade guard is correctly installed and operating properly.

Switching on:

> To start the machine by pressing the green I-button [59] on the On/Off switch [7].
When turning the switch ON stand on either side of the blade and never in front of it.

Allow saw blade to reach full speed before cutting.

Switching off:

> To stop the machine by pressing the red 0-Button [60] on the On/Off Switch [7].

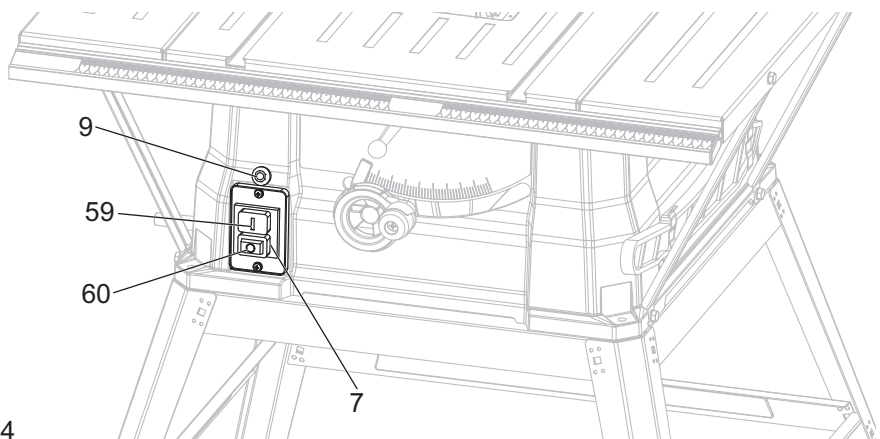

Fig. 24

Overload reset switch

- > This saw is equipped with an overload reset switch. It is situated at the immediate top of the On/Off switch.

The overload reset switch [9] (See Fig. 24) will restart the motor after it shuts off due to overloading.

If the motor stops during operation, push the switch to the OFF position. Wait approximately five minutes for the motor to cool down and push the overload reset switch. Now you can switch to the ON position again.



Warning: Risk of injury!

In order to avoid injury and prevent accidental start-up when the overload reset switch is pushed, On/Off switch should be in the OFF position, and the power cord should be unplugged from the outlet while the saw is cooling down. Overheating may be caused by an under-sized extension cord, an extension cord that is too long, misaligned parts, or a dull blade. Inspect the saw for proper set-up before using it again.

Bevel locking handle

- > The bevel locking handle [10] locks the blade in the desired tilting angle. To loosen turn it anti-clockwise. When setting the angle of the cut fully loosen it. Before turning the table saw ON, be sure it is securely tightened so that the blade will not shift during the table saw operation. (See Fig. 25)

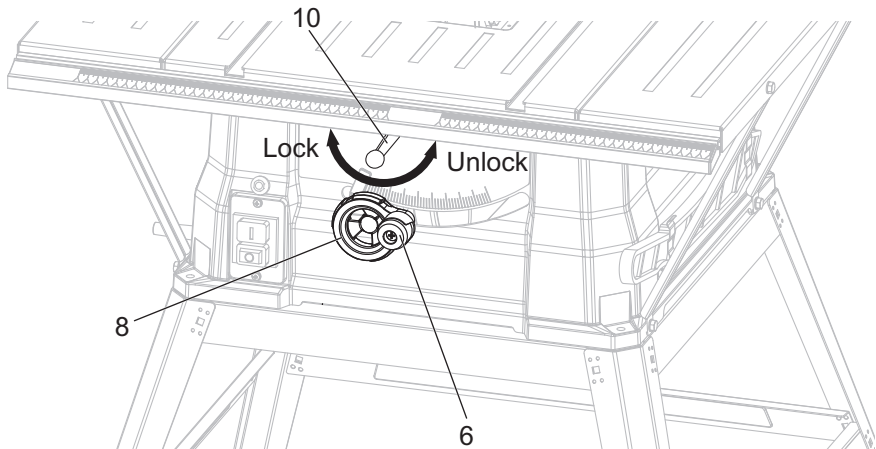

Fig. 25

Bevel adjusting handwheel

- > The saw blade can be adjusted easily between 0° and 45°. The bevel adjusting handwheel [8] is used to tilt the blade for bevel cutting. Loosen the bevel locking handle [10], then slide the bevel adjusting handwheel to the right to tilt the blade to the left and slide it to the left to tilt the blade to the right. (See Fig. 25).



NOTE: In order to be able to use the complete adjustment range of 45°, the cut height must be reduced accordingly.



Warning: Risk of injury!

Body parts or objects which are in the adjustment area can be caught by the running saw blade! Only adjust the cut height when the saw blade is standing still!

Height adjusting handle

- > The height adjusting handle [6] is used to raise and lower the blade. Turn clockwise to lower the blade and anticlockwise to raise it. (Fig. 25)
The cut height of the saw blade must be adjusted to the height of the work piece:
The saw blade must always be lowered onto the work piece.



NOTE: In order to be able to use the complete adjustment range of 45°, the cut height must be reduced accordingly.



Warning: Risk of injury!

Body parts or objects which are in the adjustment area can be caught by the running saw blade! Only adjust the cut height when the saw blade is standing still!



NOTE: To balance out possible play in the cut height adjustment, always move the saw blade into the desired position from below.

Rip fence

- > This fence is used for all ripping operations. Never rip freehand without the fence in place and securely locked.

Adjust the distance of the rip fence

- > Pull the rip fence locking handle [22] up.
- > Slide the rip fence [19] to the required position. The set position can be read off using the scale.
- > Push the rip fence locking handle [22] down.

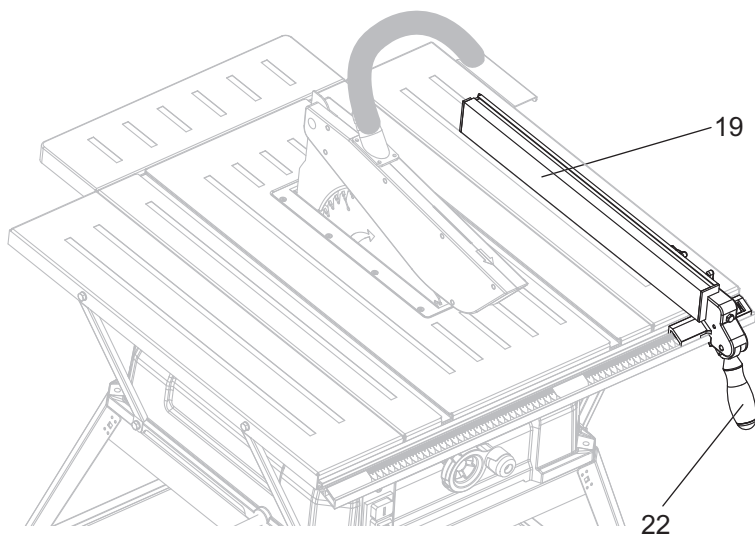

Fig. 26

Push stick

> Push stick [21] is a device used for safely pushing a work piece through the blade instead of using your hands. They can be made from scrap wood in various sizes and shapes to be used in a specific project. The stick must be narrower than the work piece, with a 90° notch in one end and shaped for a grip on the other end. Use a push stick whenever the fence is 12 cm or less from the blade. push stick should be used in place of the user's hand to guide the material between the fence and blade. When using a push stick, the trailing end of the board must be square.

A push stick against an uneven end could slip off or push the work piece away from the fence.



Warning: Risk of injury!

Do not locate the push stick to the rear of the work piece, kickback can result from the push stick pinching the work piece and binding the blade in the saw kerf if positioned improperly. It may cause serious personal injury.

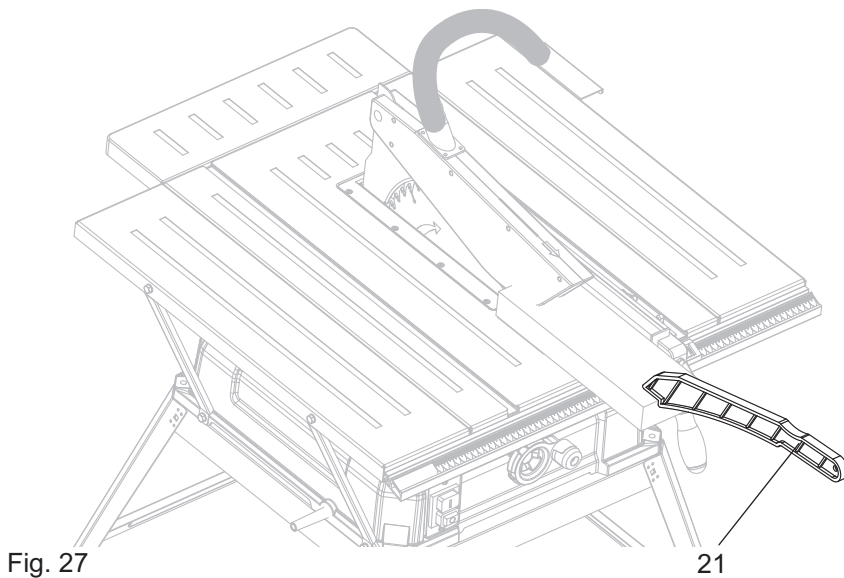

Mitre gauge

- > The head is locked in the desired position for crosscutting or mitring by tightening the locking handle.
Always lock it securely when in use.

Adjust the angle of the mitre gauge

The stop profile can be adjusted by a maximum of 60° for mitre cuts.



Warning: Risk of injury!

Do not push the parallel profile [61] too far in the direction of the saw blade. The distance between the parallel profile and the front of the saw blade should be approx. 2.5 cm.

- > Loosen the mitre gauge locking handle (62).
- > By turning the parallel profile [61], set the desired angle on the scale [63].
- > Tighten the mitre gauge locking handle (62).

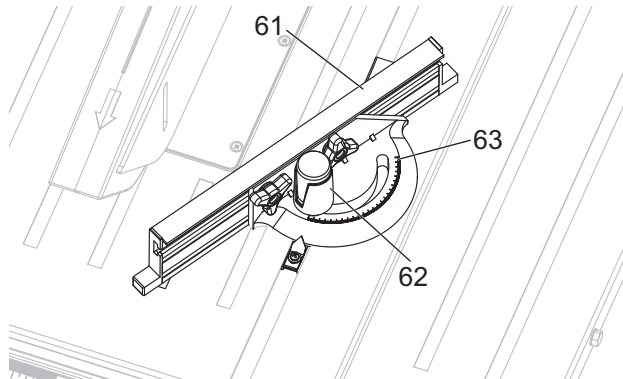

Fig. 28

BASIC TABLE SAW OPERATIONS



Warning: Risk of injury!

If the distance between the rip fence and saw blade is less than 12 cm, the push stick [21] must be used.



Warning: Risk of injury!

Always hold the guided work piece fast, never the free work piece which has been cut off.



Warning: Product damage!

Check the wood to be worked carefully. The device can be damaged severely by foreign bodies such as nails, screws, etc.



Warning: Product damage!

Always use sharp saw blades. Blunt blades can overload and damage the product.

For safety reasons, verify that the operator has read the section entitled general safety guidelines for the table saw before operating this saw. Verify the following before every time the table saw is used:

- > The blade is tight.
- > The blade bevel locking handle is locked.
- > If ripping, the rip fence locking handle is tight, and the fence is parallel to the mitre gauge groove and the blade.
- > If crosscutting, the mitre gauge locking handle is tight.
- > The blade guard and riving knife are in place, and are working properly.
- > The dust extraction hose is fixed in the slot of the hose hold.
- > Safety glasses are worn.
- > Failure to adhere to these safety rules will greatly increase the chances of injury. Before using the table saw, polish the tabletop with an automotive polishing wax in order to keep it clean, and to make it easier to slide the work piece.

There are two basic types of table saw cuts: ripping and crosscutting. Ripping refers to cutting along the length of the grain and the work piece. Crosscutting refers to either cutting across the width or across the grain of the work piece. This distinction may be hard to make with man made materials. Therefore, cutting a piece of material to a different width is ripping, and cutting across the short dimension is crosscutting.

Neither operation can be performed safely freehand: ripping requires the use of the rip fence, and crosscutting requires the use of the mitre gauge. Never use the rip fence and the mitre gauge at the same time during the cutting operation.



Warning: Risk of injury!

Do not use more than one rip fence or a combination of a mitre gauge and a rip fence at the same time during a cutting operation.

Ripping

- > Remove the mitre gauge, and secure the rip fence to the table.
- > Raise the blade until it is approximately 1/8" (3.2 mm) above the top of the work piece.
- > Place the work piece flat on the table and against the fence so that the larger portion of the work piece is between the blade and the fence. Keep the work piece approximately 1" (2.5 cm) away from the blade.

- > Turn the saw ON, and wait for the blade to reach full speed.
- > Slowly feed the work piece into the blade by pushing forward on the section of the work piece that will pass between the blade and the fence.
- > Do not place your thumbs on the table top. Always hold the work piece while the blade is turning. Do not let go of it in order to reach for the push stick. When both thumbs touch the front edge of the table, complete the cut using a push stick.
- > Always use the push stick when performing ripping operations.
- > Continue to push the work piece with the push stick until it passes the blade guard and clears the rear of the table.
- > Do not pull the work piece backward while the blade is turning. Turn the switch OFF, and unplug the power cord. Wait until the blade comes to a complete stop and slide the work piece out.

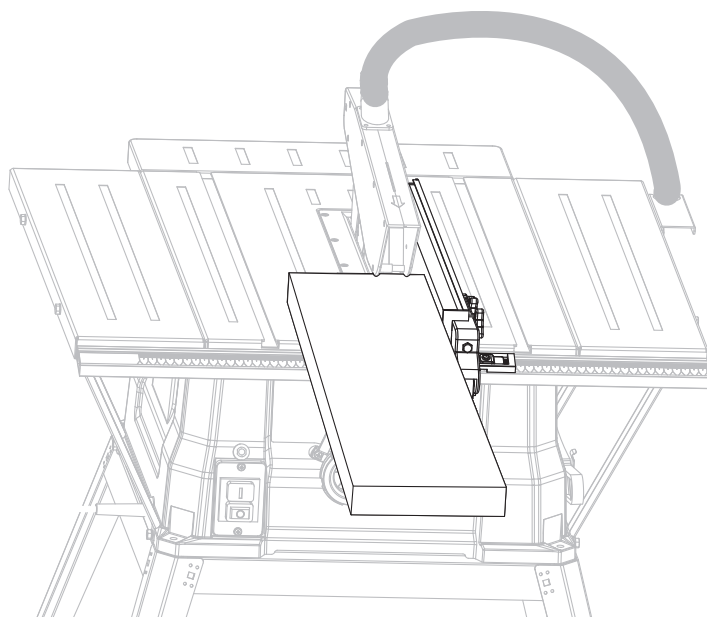

Fig. 29

Bevel ripping

- > Bevel ripping is the same as ripping, except that the blade bevel angle is set to an angle other than "0".

**Warning: Risk of injury!**

The work piece and the fence must be on the right side of the blade when cutting.

Ripping small pieces

**Warning: Risk of injury!**

Avoid injury caused by contact with the blade. Do not use this saw to make throughcuts that are narrower than 1/2" (13 mm).

- > It is not safe to rip small pieces. Instead, rip a larger piece in order to obtain the size of the desired piece.
- > When ripping a small work piece, it is not safe to place the hand between the blade and the rip fence. Use one or more push sticks to push the work piece completely past the blade.

**Warning: Risk of injury!**

If the distance between the rip fence and saw blade is less than 12 cm, the push stick must be used.

Crosscutting

- > Remove the rip fence and place the mitre gauge in the mitre gauge groove on the table.
- > Raise the blade until it is approximately 1/8" (3.2 mm) above the top of the work piece.
- > Hold the work piece firmly against the mitre gauge, with the path of the blade in line with the desired cutting line. Move the work piece to within 1" (2.5 cm) of the blade.

- > Start the saw, and wait for the blade to reach full speed. Do not stand directly in line with the saw blade's path. Instead, stand on the side where the cut is being made.
- > Keep the work piece against the parallel profile of the mitre gauge and flat against the table. Slowly push the mitre gauge with the work piece through the blade.
- > Do not attempt to pull the work piece backward while the blade is turning. Turn the switch OFF, and wait until the blade has come to a complete stop before carefully sliding the work piece out.

**Warning: Risk of injury!**

In order to avoid instability, always place the larger surface of the work piece on the table when crosscutting and/or bevel crosscutting.

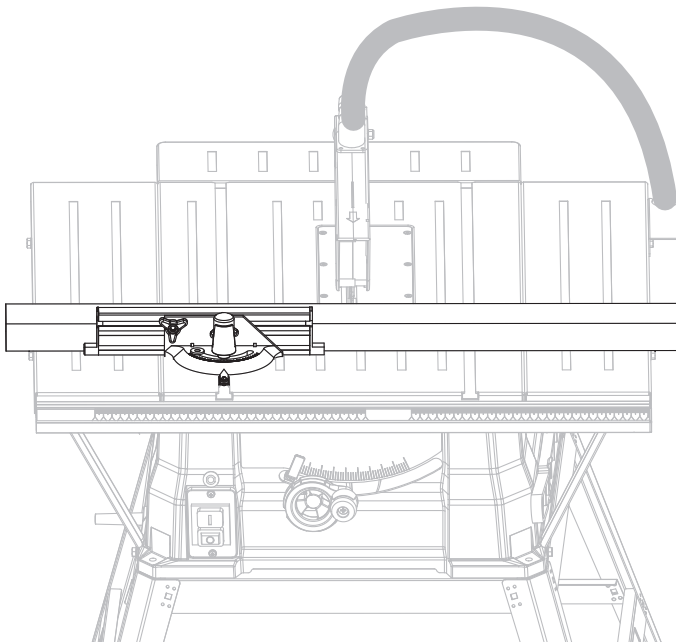

Fig. 30

Bevel crosscutting 0° - 45° blade bevel & 90° mitre angle

- > This operation is the same as crosscutting, except that the blade is at a bevel angle other than 0°.
- > Adjust the blade to the desired angle, and then tighten the blade bevel locking handle.
- > Tighten the mitre gauge locking handle at 90°.
- > Hold the work piece firmly against the parallel profile of the mitre gauge throughout the cutting operation.

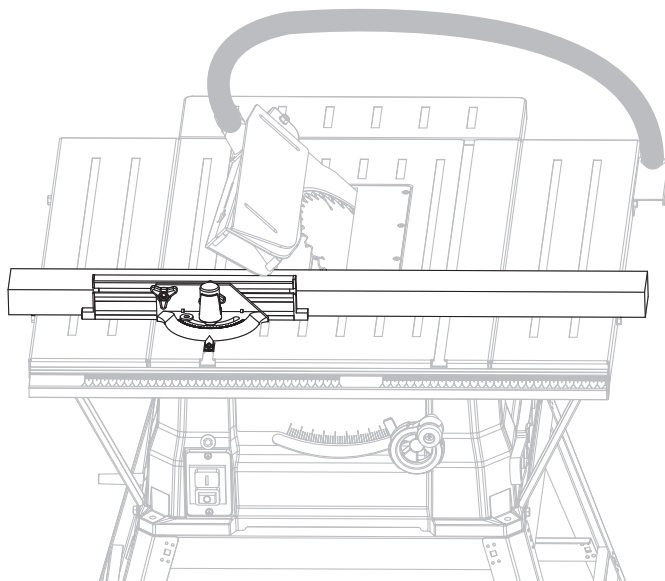

Fig. 31

Compound mitre crosscutting 0° - 45° blade bevel & 0° - 45° mitre angle

- > This sawing operation combines a mitre angle with a bevel angle.

- > Set the miter gauge to the desired angle.
- > Set the blade bevel to the desired bevel angle, and tighten the blade bevel locking handle.
- > Hold the work piece firmly against the face of the miter gauge throughout the cutting operation.

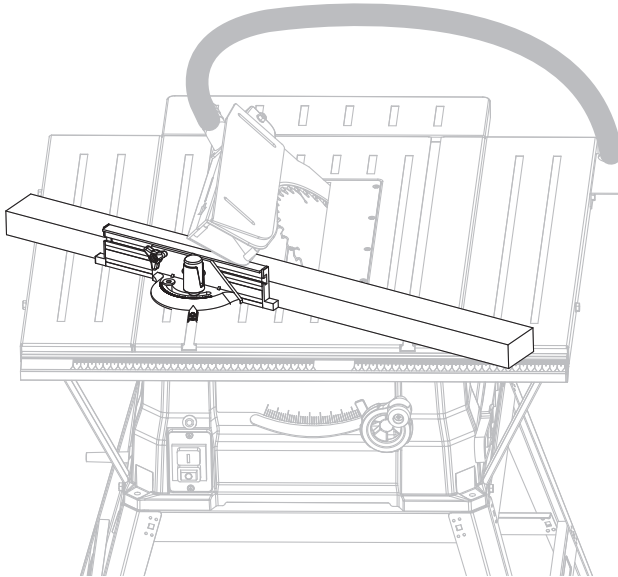

Fig. 32

Mitring: 0° - 45° mitre angle

- > This operation is the same as crosscutting, except that the miter gauge is locked at an angle other than 90°.
- > Set the blade to a 0° bevel angle, and tighten the blade bevel locking handle.
- > Set the miter gauge to the desired mitre angle, and secure it in position by tightening the miter gauge locking handle.
- > Hold the work piece firmly against the parallel profile of the miter gauge throughout the cutting operation.

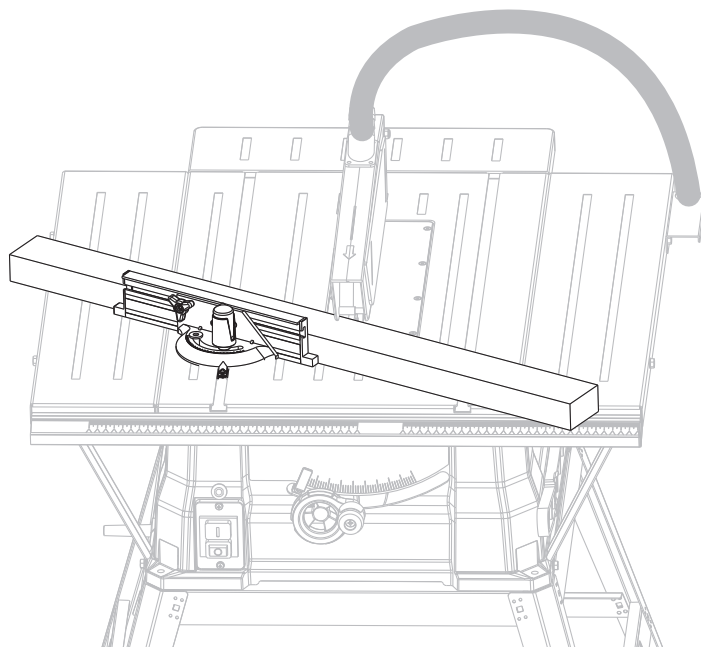

Fig. 33

ADJUSTMENT

Adjusting the bevel stops

This saw has positive stops that will quickly position the saw blade at 90° or 45° to the working table.

The angle settings of the saw have been set at the factory and, unless damaged in shipping, should not require setting during assembly. After extensive use, it may need to be checked.

Make adjustments only if necessary.

- > Unplug the saw.
- > Remove the blade guard.
- > Raise the blade to the maximum height by turning the high adjusting handle counterclockwise.

- > Using a square [63], set the blade to exactly 90°. (Fig. 34)

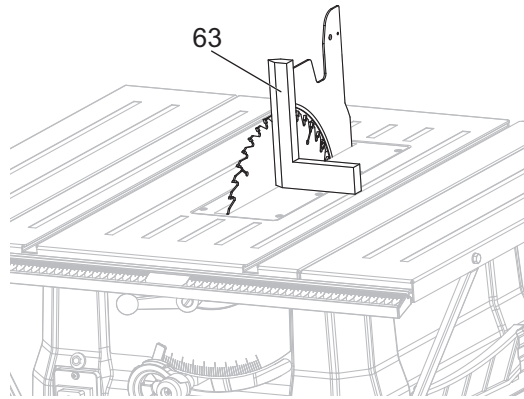

Fig. 34

- > If the blade stops beveling before it gets to 90°, loosen the 90° stop screw [64] (located on the left under the table) (Fig. 35) with the hex key (not included), and then adjust it to 90°.
- > With the blade set at 90°, slowly turn the 90° stop set screw until you feel resistance. Bevel the blade away from 90° a little, and then back to the stop.
- > Re-measure the angle, and repeat the stop adjustment as necessary until the blade stops at 90°.

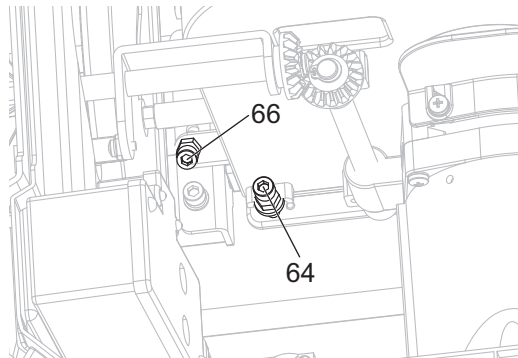

Fig. 35

- > Set the 45° stop in the same way with a triangle square [65]. The set screw [66] for the 45° stop is located on the right under table.

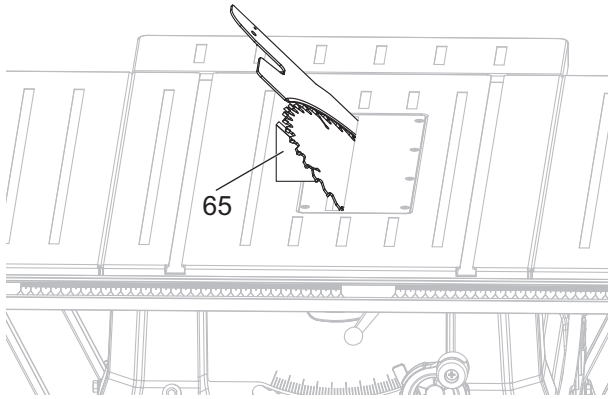

Fig. 36

In more detail...

The golden rules for care



WARNING! Always switch the product off, disconnect it from the power supply and let the product cool down before performing inspection, maintenance and cleaning work!

- > Keep the product clean. Remove chips from it after each use and before storage.
- > Regular and proper cleaning will help ensure safe use and prolong the life of the product.
- > Inspect the product before each use for worn and damaged parts. Do not operate it if you find broken and worn parts.



WARNING! Only perform repairs and maintenance work according to these instructions! All further works must be performed by a qualified specialist!

General cleaning



WARNING! Danger of electric shock!

Never spray the device with water or subject it to water. To clean, never use cleansers or solvents. This can cause irreparable damage to the device. The plastic parts can be eaten away by the chemicals.

- > Keep the ventilation slots of the machine clean to prevent overheating of the engine.
- > Regularly clean the machine housing with a soft cloth, preferably after each use.
- > Keep the ventilation slots free from dust and dirt.
- > If the dirt does not come off use a soft cloth moistened with soapy water.
- > Never use solvents such as petrol, alcohol, ammonia water, etc. These solvents may damage the plastic parts.

Lubrication

- > All motor bearings are permanently lubricated at the factory, and do not require any additional lubrication.
- > Use graphite or silicone to lubricate all mechanical parts of the table saw where a pivot or threaded rod is present.
- > Dry lubricants do not hold sawdust like oil or grease.

To replace the saw blade

When you need replace the saw blade, please follow the procedure as belowing:

- > Unplug the saw.
- > Loosen the hex nut and remove the blade guard.
- > Turn the bevel adjusting handwheel to set the saw blade to 90° and lock the bevel-locking handle, then turn height adjusting handle clockwise to drop the saw blade to lowest position.
- > Loosen the eight cross-screws and remove the table insert.
- > Turn height adjusting handle counterclockwise to raise blade to maximum height.
- > Using one opened-ended blade wrench [23], place the flat open end on the flats on the outer blade flange [67].
- > Using the other opened-ended blade wrench [23], place the flat open end on the flats on the arbor nut [68]. Holding both wrenches firmly, pull the opened-ended blade wrench [23] on the arbor nut forward to the front of the machine.



WARNING! Arbor shaft has left-hand threads. Be extremely careful when loosening arbor nut. Keep firm grasp on both wrenches. Do not allow hands to slip and contact blade.

- > Remove arbor nut [68], outer blade flange [67] and saw blade [2].
- > Place one new blade [2] on arbor shaft [69]. Make sure saw blade teeth point down at the front side of saw table. Place outer flange [67] and arbor nut [68] on arbor shaft and verify that large, flat surface of the outer flange faces the saw blade and the saw blade (2) is firmly seated against the inner flange (70). And all the items are snug against the arbor housing.
- > Use blade wrenches to tighten nut securely. Do not overtighten.



WARNING! Product damage! When installing, make sure to heed the turning direction of the saw blade!



NOTE: During installation, make sure that the saw blade is sitting correctly on the arbor.



WARNING! Risk of injury!

The arbor nut may not be tightened too much. Product damage and severe injuries may result!

- > Lower the saw blade to lowest position and replace the table insert.
- > Raise the saw blade to maximum height and replace the blade guard.

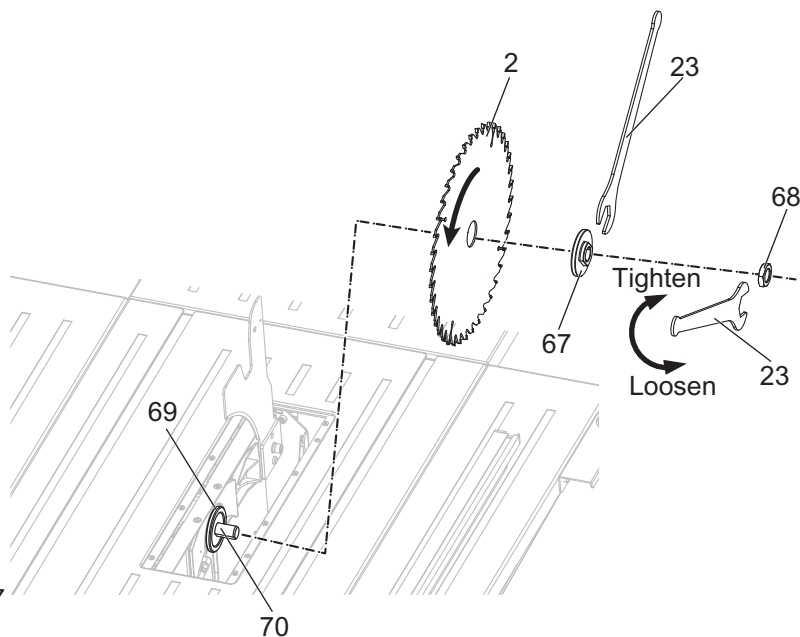

Plug replacement

If you need to replace the fitted plug then follow the instructions below.

Important

The wires in the mains lead are coloured in accordance with the following code:

Blue - Neutral

Brown - Live

As the colours of the wires in the mains lead of this appliance may not correspond with the coloured markings identifying the terminals in your plug, proceed as follows.

The wire which is coloured **blue** must be connected to the terminal which is marked with **N**. The wire, which is coloured brown, must be connected to the terminal, which is marked with the letter **L**.

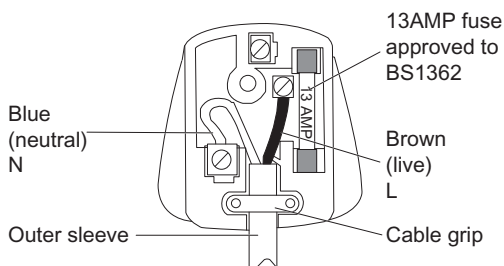

Fig. 38



Warning: Never connect live or neutral wires to the earth terminal of the plug. Only fit an approved 13 Amp BS1363/A plug and the correct rated fuse.



NOTE: If a moulded plug is fitted and has to be removed take great care in disposing of the plug and severed cable, it must be destroyed to prevent engaging into a socket. If the supply cord is damaged it must be replaced by a service agent or a similarly qualified person in order to avoid hazard.

Repair

- > This product does not contain any parts that can be repaired by the consumer. Contact a qualified specialist to have it checked and repaired.
- > If the power cord is damaged, it must be replaced by the manufacturer, its service agent or similarly qualified person in order to avoid a safety hazard.

Transport

- > Drop the saw blade to the lowest position.
- > Remove the attached parts which protrude over the saw.
- > Carry the produce with the help of another person.
- > When shipping, use the original packaging if possible.



NOTE: When transporting the product use only transportation devices and do never use guards for handling, lifting or transportation.



Warning: Risk of injury!

During transportation the upper part of the saw blade should be covered; for example by the guard.

Storage



Warning: Risk of injury!

Store the product so that it cannot be switched on by unauthorized persons.

Ensure that nobody can injure themselves on the product while it is stationary.



NOTE: Product damage!

Do not store the product unprotected in a humid environment.

- > Always store the product in a dry place.

- > Always store the product in a place that is inaccessible to children.
- > Store the product, operating instructions and where necessary the accessories in the original packaging. In this way you will always have all the information and parts ready to hand.

Recycling and disposal



> Waste electrical products should not be disposed of with household waste. Please recycle where facilities exist. Check with your Local Authority or local store for recycling advice.

Trouble shooting

Suspected malfunctions are often due to causes that the users can fix themselves. Therefore check the product using this section. In most cases the problem can be solved quickly.



WARNING! Only perform the steps described within these instructions! All further inspection, maintenance and repair work must be performed by an authorised service centre or a similarly qualified specialist if you cannot solve the problem yourself!

Problem	Possible cause	Solution
Motor not running.	<ol style="list-style-type: none"> 1. No mains voltage. 2. Undervoltage relay triggered by temporary loss of power. 3. Motor overheated. 	<ol style="list-style-type: none"> 1. Check cable, plug, socket and fuse. 2. Switch device on again. 3. Eliminate cause of the overheating, let cool down for a few minutes, then switch on again.
Blade makes poor cuts.	<ol style="list-style-type: none"> 1. Blade is dull or dirty. 2. Blade is the wrong type for cut being made. 3. Blade is mounted backwards. 	<ol style="list-style-type: none"> 1. Clean, sharpen or replace the blade. 2. Replace with the proper type. 3. Remount the blade.
Excess vibration.	<ol style="list-style-type: none"> 1. Blade is out of balance. 2. Blade is damaged. 3. Saw is not mounted securely. 4. Work surface is uneven. 5. Blade is warped. 	<ol style="list-style-type: none"> 1. Replace blade. 2. Replace blade. 3. Tighten all hardware. 4. Reposition on flat surface. 5. Replace blade.
bevel adjusting handwheel is hard to turn.	<ol style="list-style-type: none"> 1. Gear and screw post inside the cabinet are clogged with sawdust. 	<ol style="list-style-type: none"> 1. Clean the gear and screw post.

Problem	Possible cause	Solution
The work piece is touching the back of the saw blade and is jumping out.	<ol style="list-style-type: none"> 1. The fence is not being used. 2. The saw blade is thicker than the riving knife or the riving knife is not being used. 3. The blade is dull. 4. The work piece has not been kept in its place until after sawing. 5. Mitre gauge locking handle is loosen. 	<ol style="list-style-type: none"> 1. Use the fence. 2. Replace blade or mount the riving knife. 3. Replace blade. 4. Keep the work piece in place until finish the sawing. 5. Tighten the mitre gauge locking handle.
Saw does not make accurate 90° or 45° cuts.	<ol style="list-style-type: none"> 1. Positive stops inside the cabinet need adjusting (Bevel cuts). 	<ol style="list-style-type: none"> 1. Adjust the positive stops.

TITAN

Declaration of Conformity

We, Importer
Titan Power Tools (UK) Ltd
Trade House, Mead Avenue, BA22 8RT

Declare that the product:
Designation: 1500W table saw
Model: TTB674TAS

Complies with the following Directives:
2014/30/EU Electromagnetic Compatibility Directive
2006/42/EC Machinery Directive

2011/65/EU Restrictions of the Use of Certain Hazardous Substances in Electrical and Electronic Equipment

2012/19/EU Waste Electrical and Electronic Equipment (WEEE)
Regulation (EC) No 1907/2006, concerning the Registration, Evaluation, Authorization and Restriction of Chemicals (REACH).

Standards and technical specifications referred to:

EN 61029-1:2009+A11:2010
EN 61029-2-1:2012
EN 55014-1:2006/A2:2011
EN 55014-2:1997/A2:2008
EN 61000-3-2:2014
EN 61000-3-11:2000

This statement covers machines whose number series is between 1 and 100000.

Authorised Signatory and technical file holder
Date : 17/10/2016

Signature: 



Name / title: John Fretwell / Quality Assurance Manager
Titan Power Tools (UK) Ltd. Trade House, Mead Avenue, BA22 8RT

1500W TABLE SAW

TTB674TAS



Titan Power Tools (UK) Ltd
Trade House, Mead Avenue,
BA22 8RT
