

VG263-2

2 Heavy duty aluminium roof bars - Volkswagen Transporter T5

SUPPLIED COMPONENTS

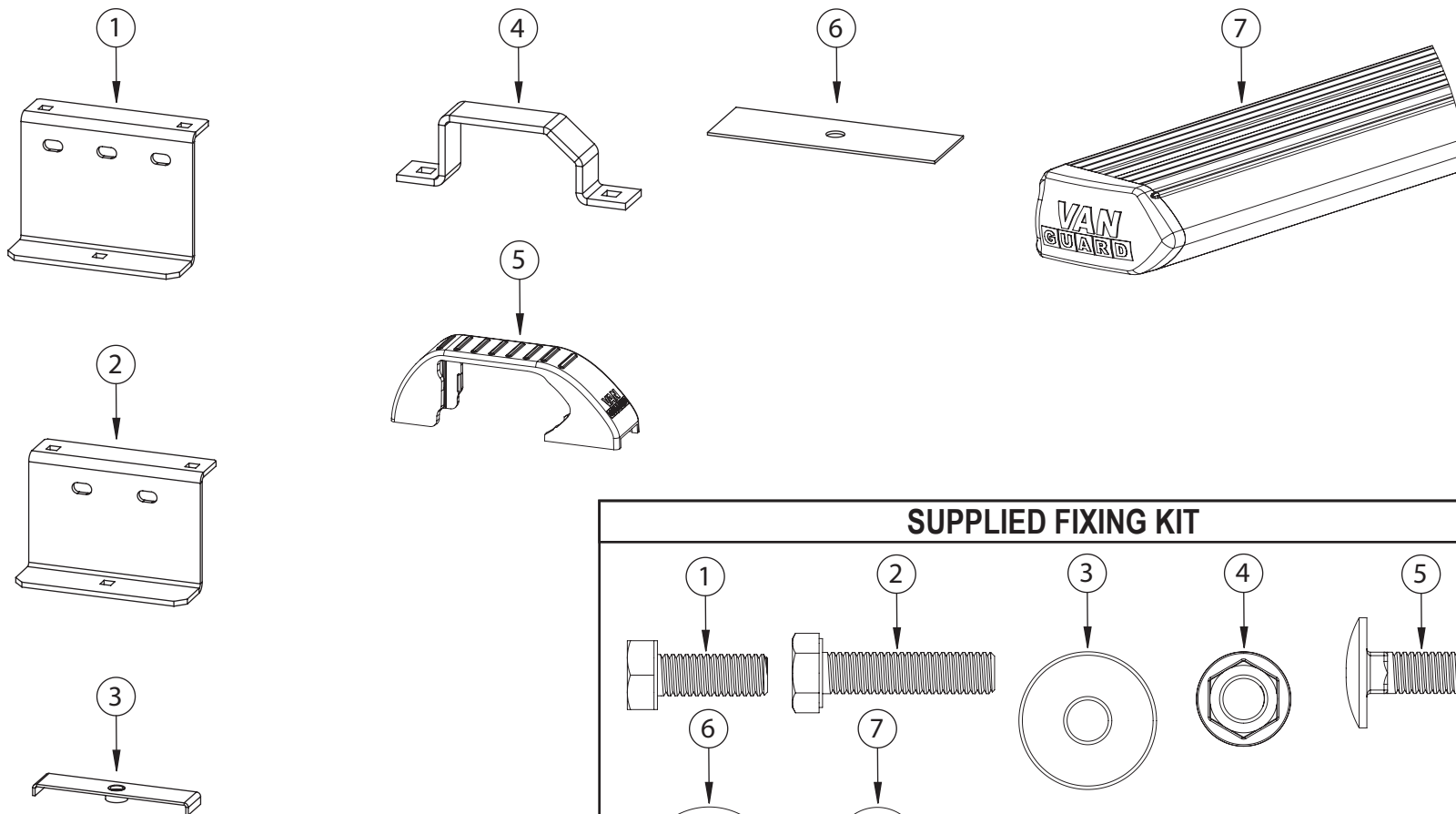

#	DESCRIPTION	QTY
1	REAR ROOF BRACKET	2
2	MIDDLE ROOF BRACKET	2
3	RAIL FIXING PLATE	4
4	TOP HAT	4
5	TOP HAT COVER	4
6	H90 RUBBER PAD	4
7	ROOF BAR	2

SUPPLIED FIXING KIT

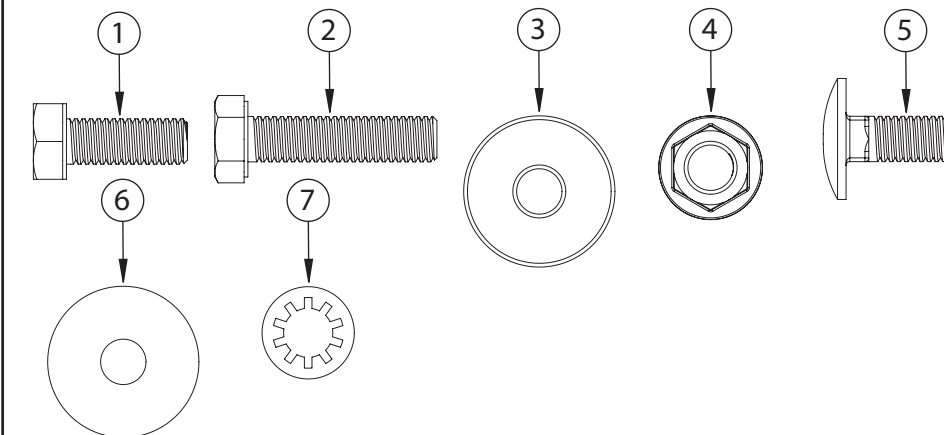

#	DESCRIPTION	QTY
1	M6x16 HEX BOLT	4
2	M6x25 HEX BOLT	4
3	M6 WASHER	4
4	M6 SERRATED FLANGE NUT	8
5	M6x16 COACH BOLT	8
6	RUBBER WASHER	4
7	M6 SHAKEPROOF	4

TOOLS REQUIRED: 10mm SPANNER / RATCHET

This FITTING INSTRUCTION is the property of VAN GUARD ACCESSORIES LTD. and must not be used for manufacturing purposes, copied nor communicated in any way to third parties without written permission from VAN GUARD ACCESSORIES LTD.

IN8082_A - IW - 03/05/2013

Van Guard Accessories Ltd
 Fair Oak Close, Exeter Airport Business Park,
 Exeter, Devon, EX5 2UL
www.van-guard.co.uk

1

The following page is for vehicles with threaded insert fixing points. If your vehicle has a t-rail please refer to page 2.2.

The roof brackets need to be positioned on the vehicle as shown below. The middle brackets can be secured to either middle fixing point.

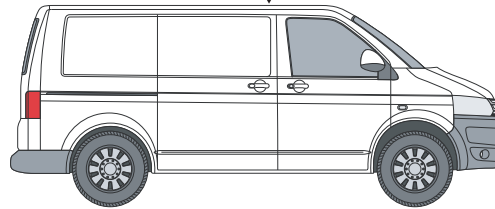
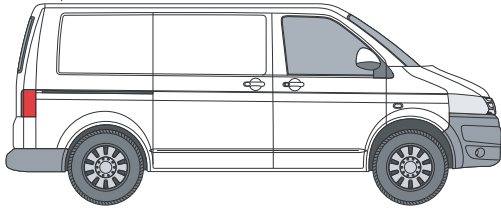
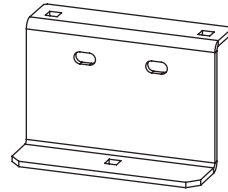
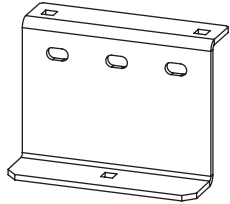
**2**

Stick rubber pads to the underside of all roof brackets.

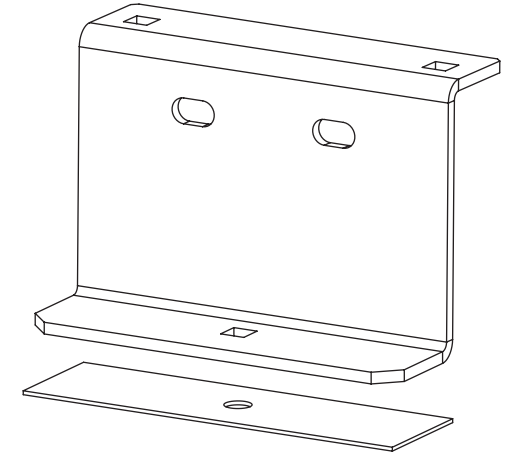
**3**

Remove roof plugs to reveal the vehicles fixing points.

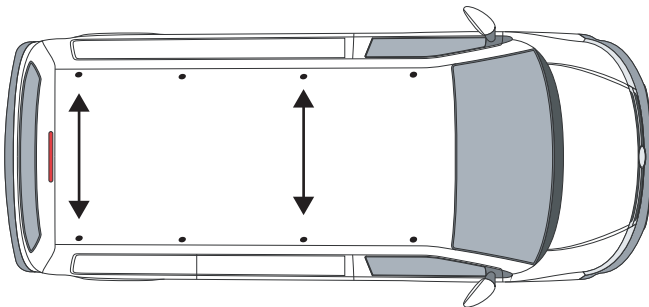
**4**

Secure roof brackets to the fixing points using M6x16* hex bolts, M6 shakeproofs, M6 washers & rubber washers. Ensure that the top hat flange is facing inwards. If M6x16 hex bolts are too small use the M6x25 hex bolts provided instead.

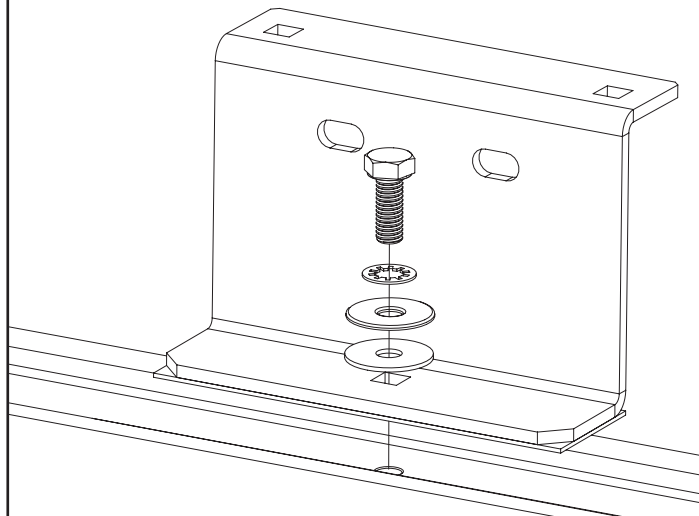
**5**

Place roof bars onto the roof brackets with the t-slot facing upwards, secure using top hat brackets, M6x16 coach bolts & M6 serrated nuts.

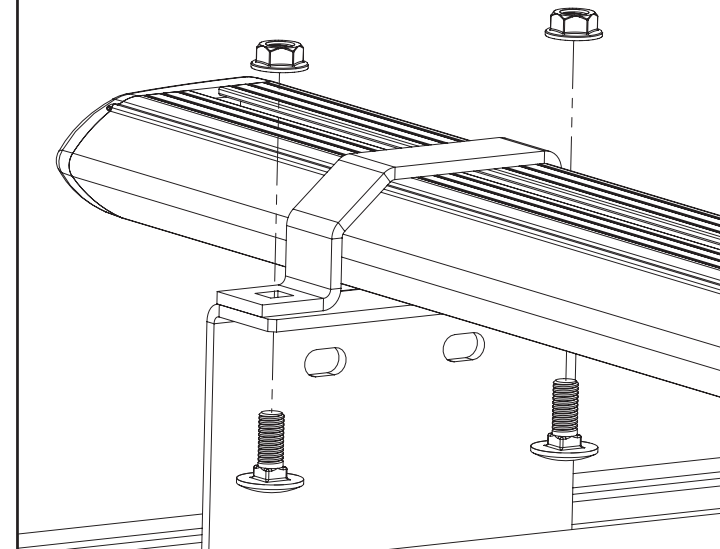

1 The following page is for vehicles with a t-rail fixing. If your vehicle has threaded insert fixing points please refer to page 2.1.

The roof brackets need to be positioned on the vehicle as shown below.

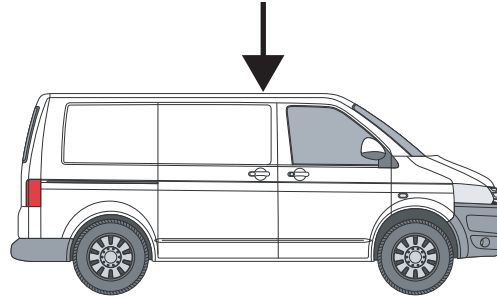
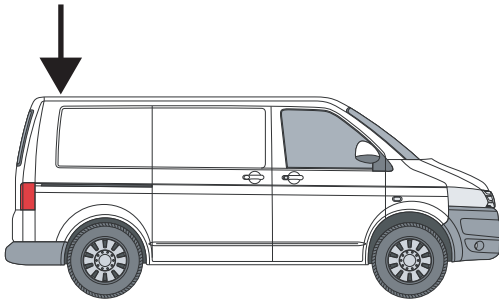
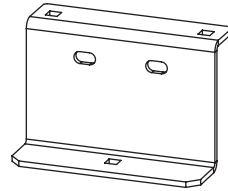
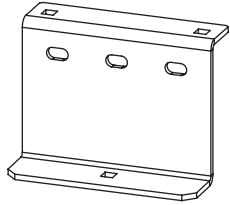

2 Stick rubber pads to the underside of all roof brackets.

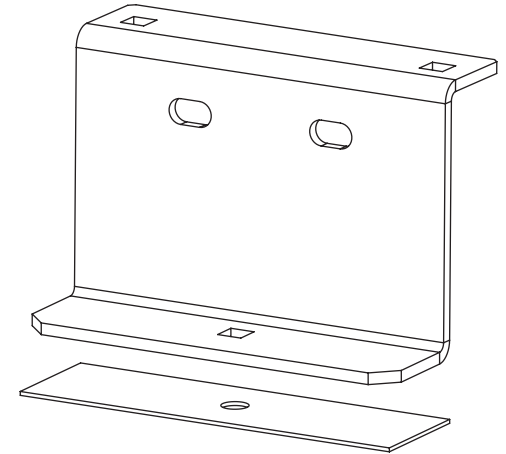

3 Slide the rail fixing plates into the vehicles t-rail.

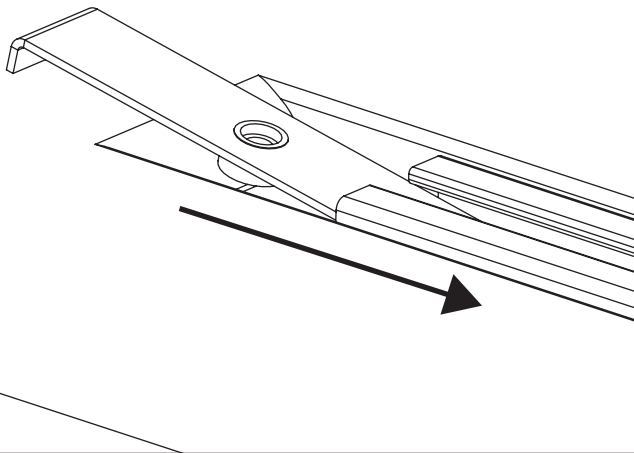

4 Secure roof brackets to the rail plate using M6x16 hex bolts, M6 shakeproofs, M6 washers & rubber washers. Ensure that the top hat flange is facing inwards.

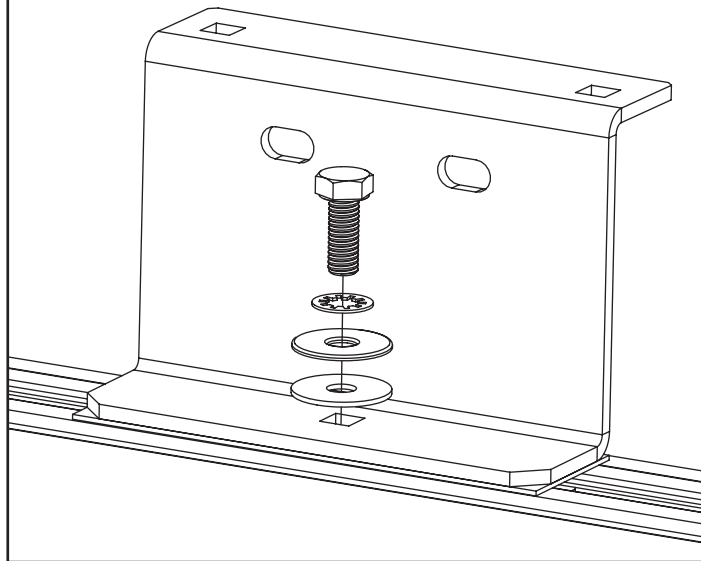

5 Place roof bars onto the roof brackets with the t-slot facing upwards, secure using top hat brackets, M6x16 coach bolts & M6 serrated nuts.

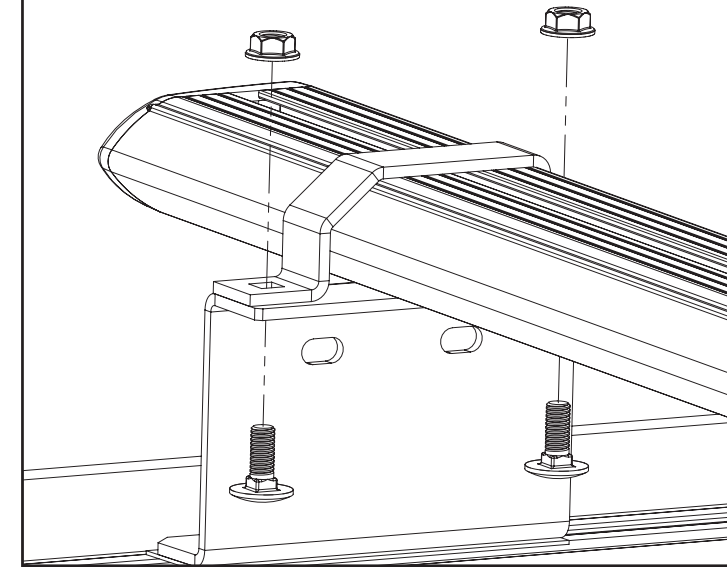

6

Flex the top hat covers over the top hat brackets into position as shown below. Ensure that the covers click into the front and rear of the top hat brackets.

1.

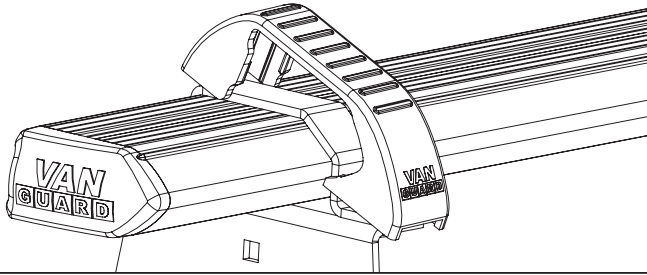

2.

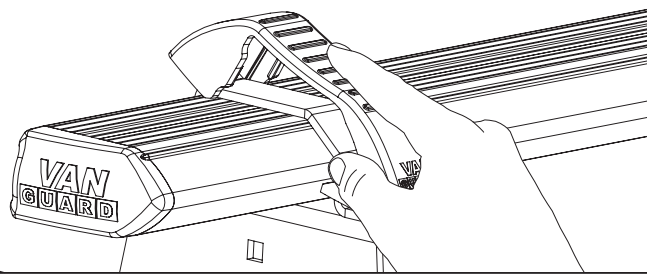

3.

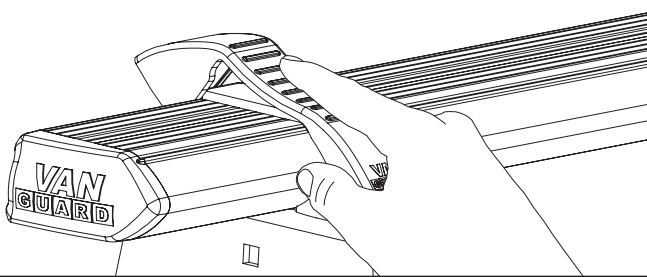

4.

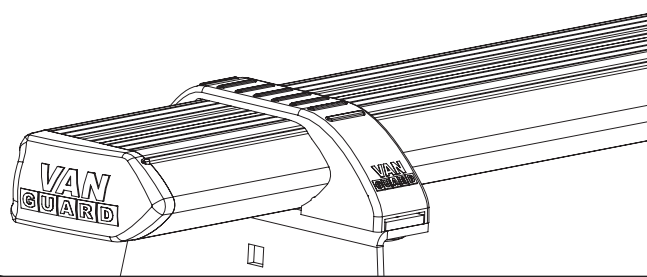
**7**

Once in position tighten all fixings to 8Nm. Periodically check all fixings.



**TIGHTEN
TO
8Nm**

NOTES:

Maximum load is 55kg per bar. Please check that the vehicle manufacturers load bearing capacity for the roof is not exceeded. (Refer to the vehicle handbook)

Periodically check all fixings.

Retain these instructions for future reference.

VAN

GUARD