

VG230-3 3 Heavy duty aluminium roof bars - LDV Maxus

SUPPLIED COMPONENTS

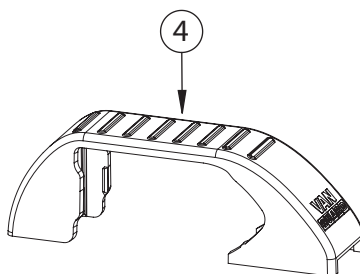
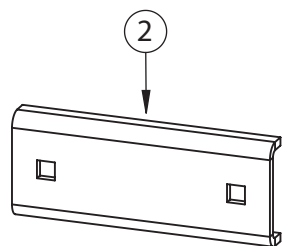
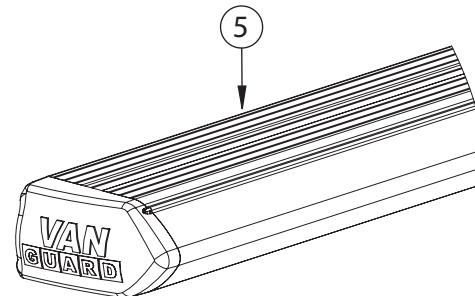
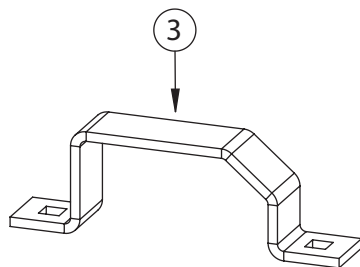
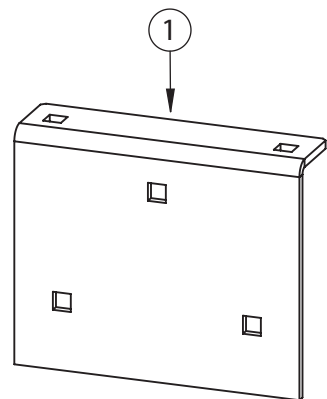

#	DESCRIPTION	QTY
1	ROOF BRACKET	6
2	FIXING BRACKET	6
3	TOP HAT	6
4	TOP HAT COVER	6
5	ROOF BAR	3

SUPPLIED FIXING KIT

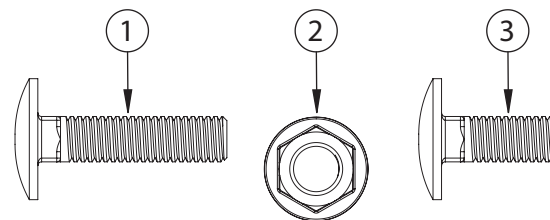

#	DESCRIPTION	QTY
1	M6x25 COACH BOLT	12
2	M6 SERRATED FLANGE NUT	24
3	M6x16 COACH BOLT	12

TOOLS REQUIRED: 10mm SPANNER / RATCHET

This FITTING INSTRUCTION is the property of VAN GUARD ACCESSORIES LTD. and must not be used for manufacturing purposes, copied nor communicated in any way to third parties without written permission from VAN GUARD ACCESSORIES LTD.

IN8072_A - IW - 03/05/2013

Van Guard Accessories Ltd
 Fair Oak Close, Exeter Airport Business Park,
 Exeter, Devon, EX5 2UL
www.van-guard.co.uk

1 Loosely secure the roof bars onto the roof brackets using top hat brackets, M6x16 coach bolts & M6 serrated nuts. Ensure that the roof bar inserts are facing upwards.

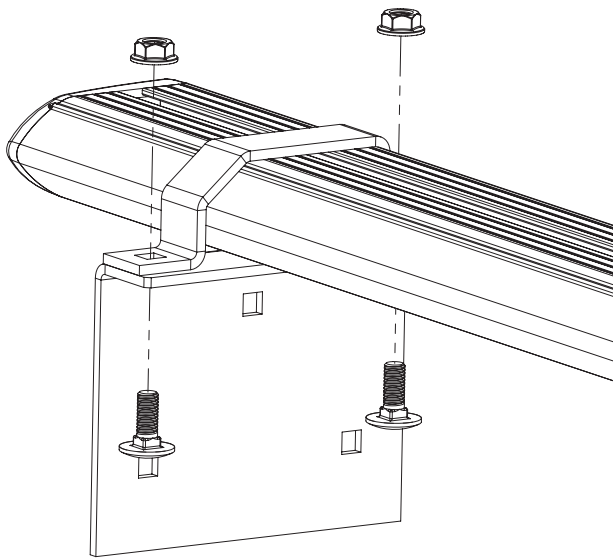

2 Place assembled roof bars onto the vehicles roof and clamp the roof brackets to the vehicles side rail using M6x25 coach bolts, fixing brackets & M6 serrated nuts.

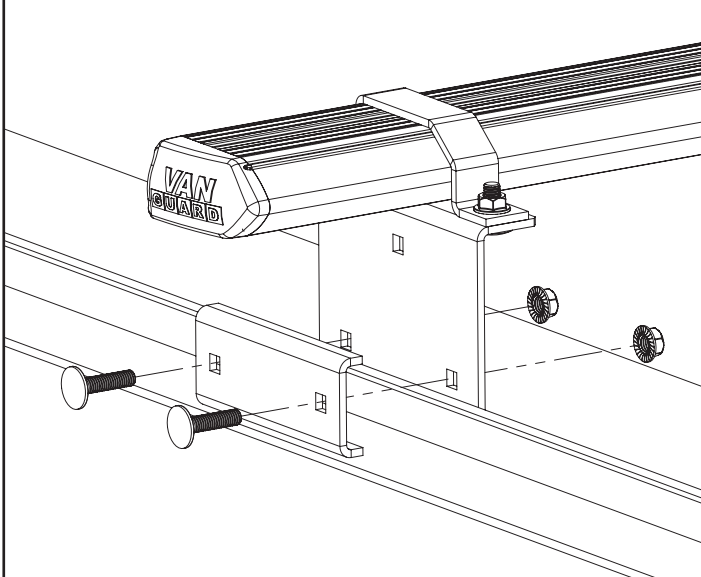

INTENTIONALLY LEFT BLANK

3 Flex the top hat covers over the top hat brackets into position as shown below. Ensure that the covers click into the front and rear of the top hat brackets.

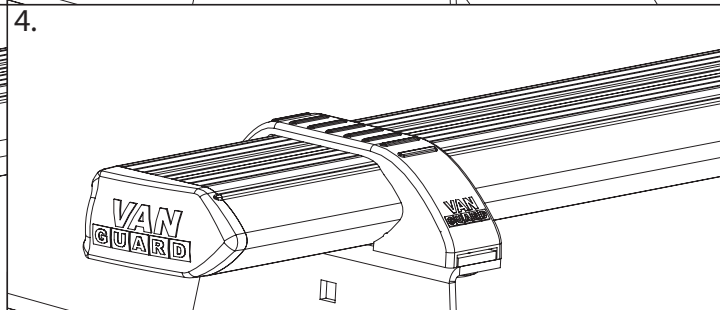
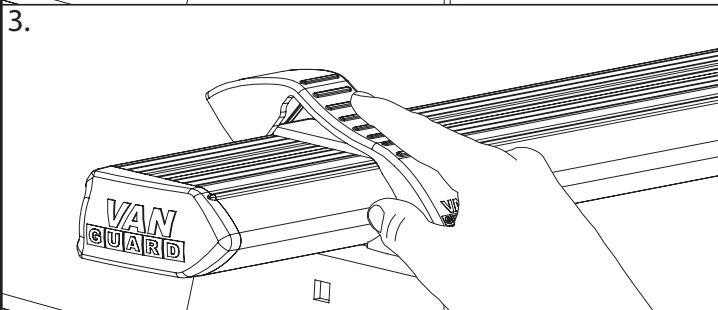
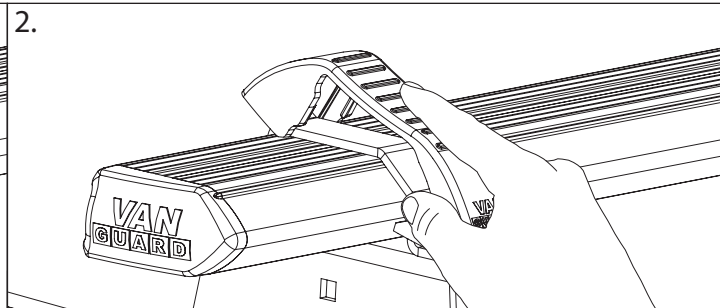
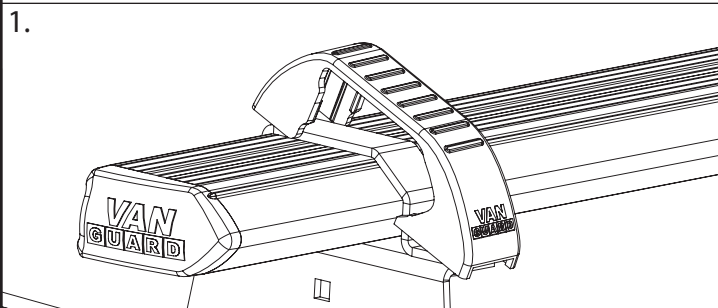

4 Once in position tighten all fixings to 8Nm. Periodically check all fixings.



**TIGHTEN
TO
8Nm**

NOTES:

Maximum load is 55kg per bar. Please check that the vehicle manufacturers load bearing capacity for the roof is not exceeded. (Refer to the vehicle handbook)

Periodically check all fixings.

Retain these instructions for future reference.