

VG187-3

3 bar aluminium roof rack - Vauxhall Combo 2001 - 2012

SUPPLIED COMPONENTS

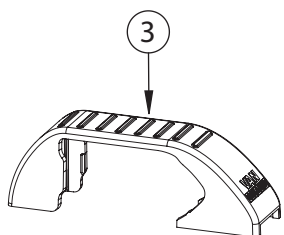
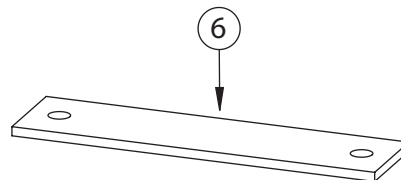
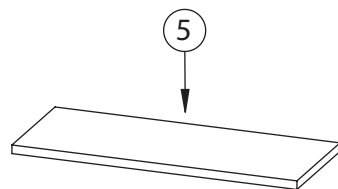
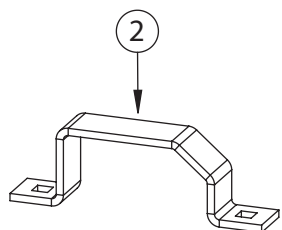
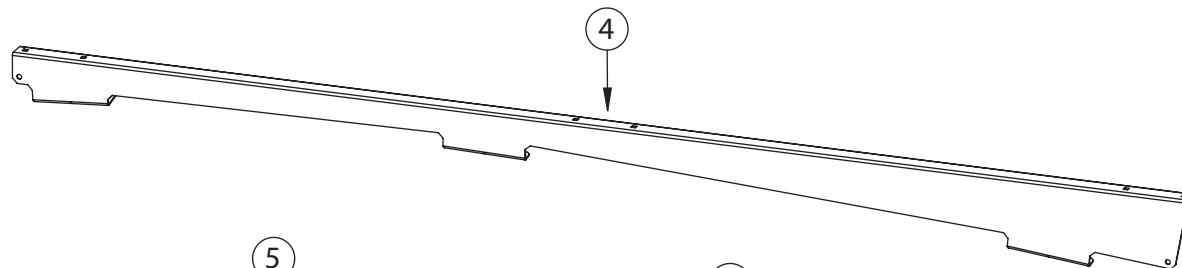
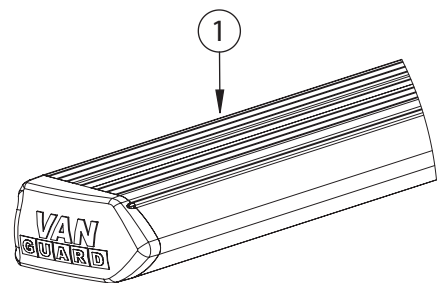

#	DESCRIPTION	QTY
1	ROOF BAR	3
2	TOP HAT	6
3	TOP HAT COVER	6
4	SIDE RAIL	2
5	K100 RUBBER PAD	2
6	H120 RUBBER PAD	4

SUPPLIED FIXING KIT

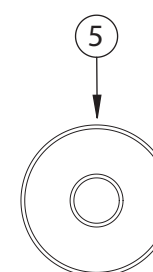
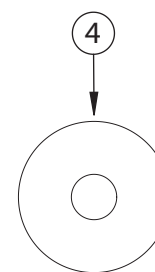
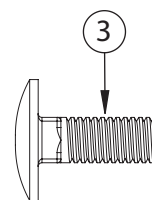
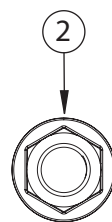
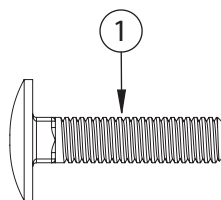

#	DESCRIPTION	QTY
1	M6x25 COACH BOLT	8
2	M6 SERRATED NUT	20
3	M6x16 COACH BOLT	12
4	RUBBER WASHER	8
5	M6 WASHER	8

TOOLS REQUIRED: 10mm SPANNER / RATCHET

This FITTING INSTRUCTION is the property of VAN GUARD ACCESSORIES LTD. and must not be used for manufacturing purposes, copied nor communicated in any way to third parties without written permission from VAN GUARD ACCESSORIES LTD.

IN8130_A - IW - 03/05/2013

Van Guard Accessories Ltd
Fair Oak Close, Exeter Airport Business Park,
Exeter, Devon, EX5 2UL

www.van-guard.co.uk

1 The side rails are handed to suit both sides of the vehicle. Stick rubber pads to the underside of the side rail feet.

ILLUSTRATION BELOW SHOWS THE OFFSIDE SIDE RAIL

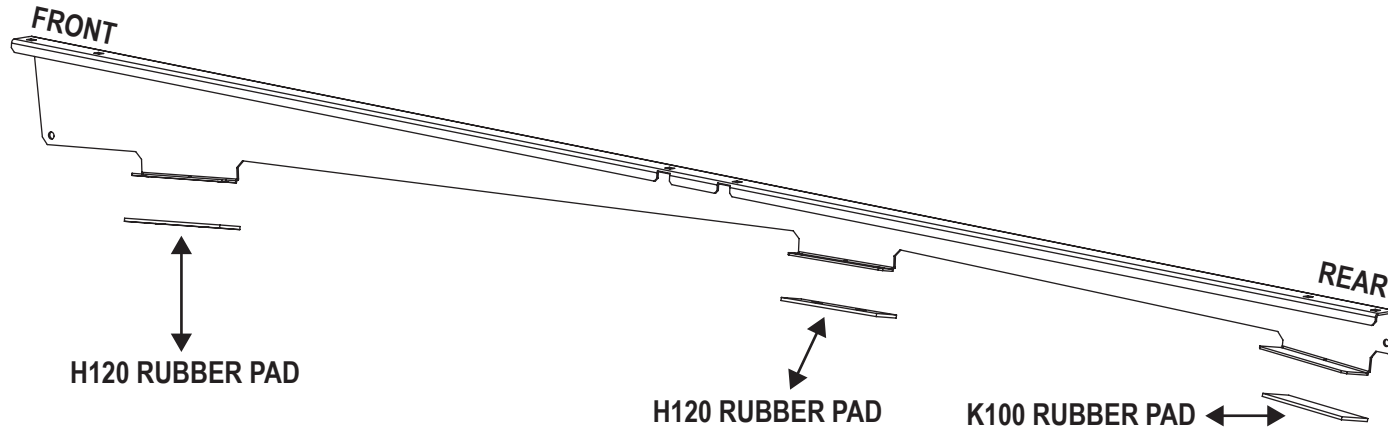

2 Remove roof plugs to reveal the vehicles fixing points. Please note there is no fixing for the rear foot of the side rail, this therefore rests on the roof as a support bracket. **No drilling is required to fit this product.**

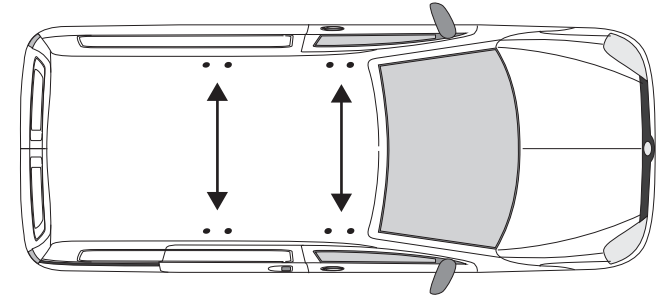

3 Secure the side rails to the vehicles fixing points by bolting through the fixing points using M6x25 coach bolts & rubber washers, secure under the roof using M6 washers & M6 serrated nuts.

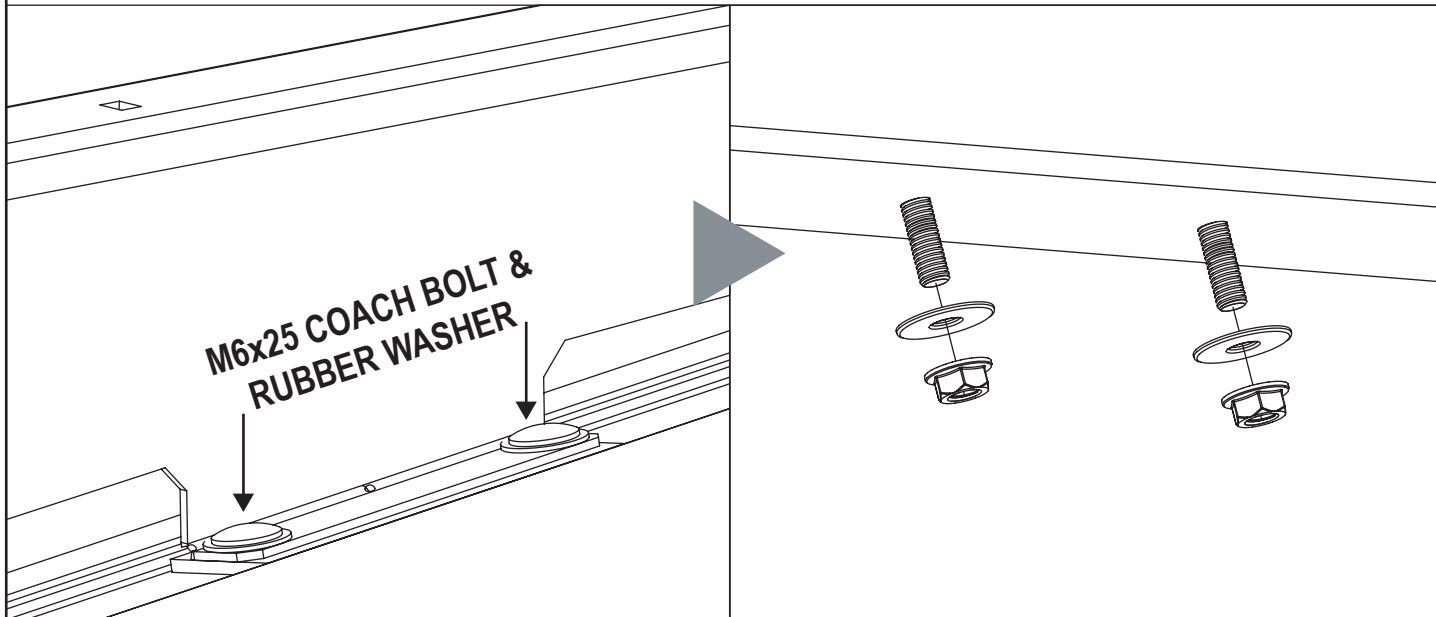

4 Place roof bars onto the side rails with the t-slot facing upwards, secure using top hat brackets, M6x16 coach bolts & M6 serrated nuts.

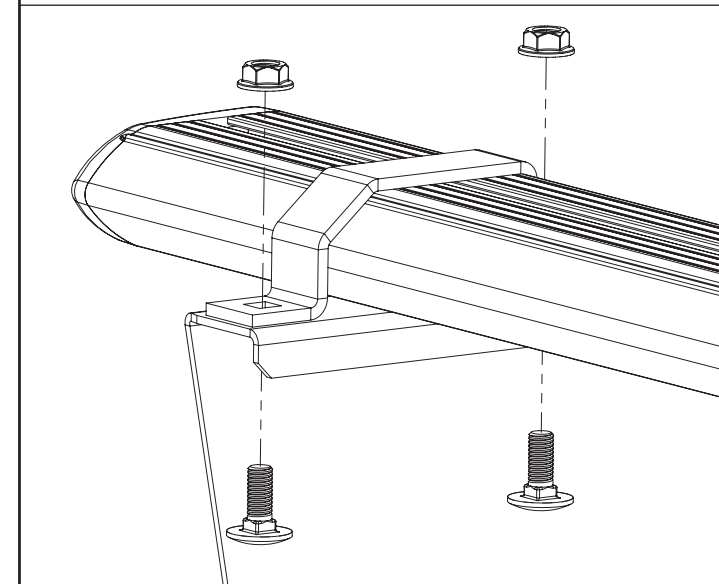

5

Flex the top hat covers over the top hat brackets into position as shown below. Ensure that the covers click into the front and rear of the top hat brackets.

1.

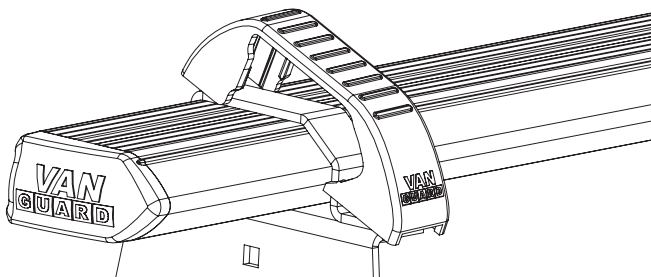

2.

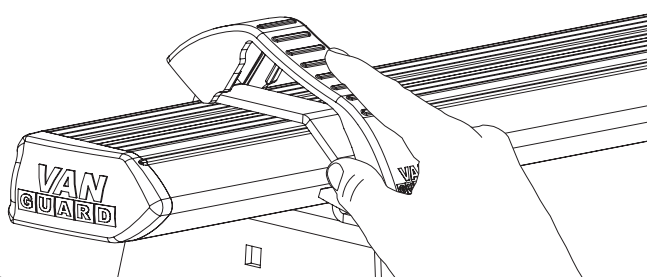

3.

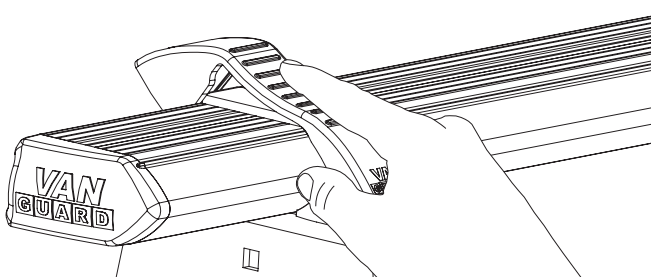

4.

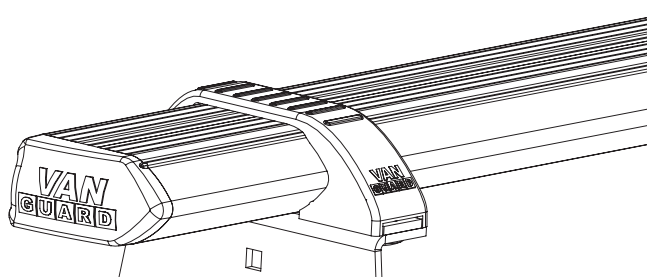
**6**

Once in position tighten all fixings to 8Nm. Periodically check all fixings.



**TIGHTEN
TO
8Nm**

NOTES:

Maximum load is 55kg per bar. Please check that the vehicle manufacturers load bearing capacity for the roof is not exceeded. (Refer to the vehicle handbook)

Periodically check all fixings.

Retain these instructions for future reference.

VAN

GUARD