

VG236-2

2 Heavy duty aluminium roof bars - Mercedes Sprinter 2006 on / Volkswagen Crafter

SUPPLIED COMPONENTS

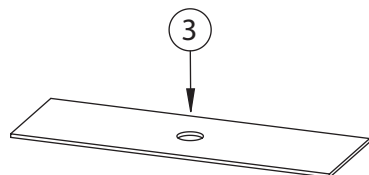
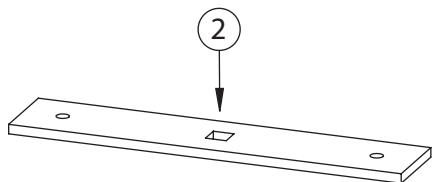
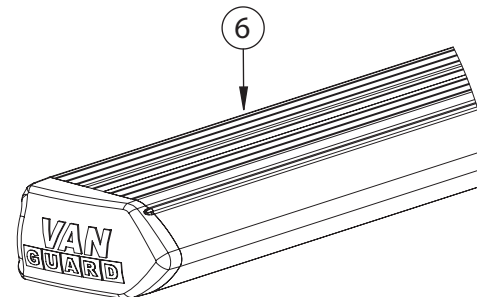
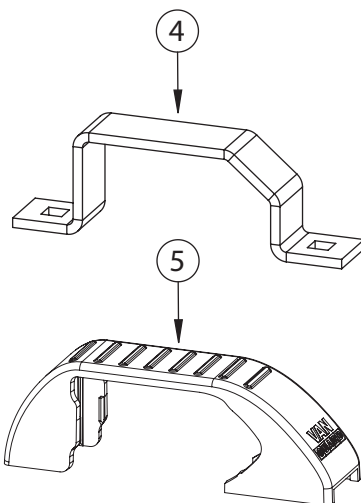
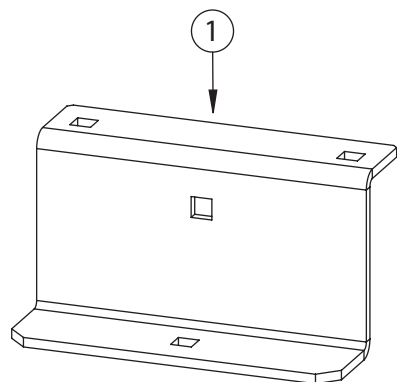

SUPPLIED FIXING KIT

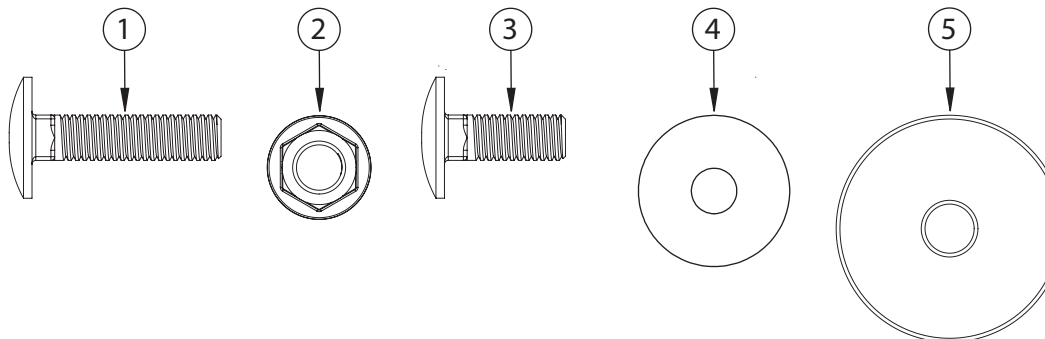

#	DESCRIPTION	QTY
1	ROOF BRACKET	4
2	FIXING PLATE	4
3	H90 RUBBER PAD	4
4	TOP HAT	4
5	TOP HAT COVER	4
6	ROOF BAR	2

#	DESCRIPTION	QTY
1	M6x25 COACH BOLT	4
2	M6 SERRATED FLANGE NUT	12
3	M6x16 COACH BOLT	8
4	RUBBER WASHER	4
5	M6 WASHER	4

TOOLS REQUIRED: 10mm SPANNER / RATCHET

This FITTING INSTRUCTION is the property of VAN GUARD ACCESSORIES LTD. and must not be used for manufacturing purposes, copied nor communicated in any way to third parties without written permission from VAN GUARD ACCESSORIES LTD.

IN8143_A - IW - 19/04/2016

Van Guard Accessories Ltd
 Fair Oak Close, Exeter Airport Business Park,
 Exeter, Devon, EX5 2UL
www.van-guard.co.uk

1 Stick rubber pads to the underside of the roof brackets.

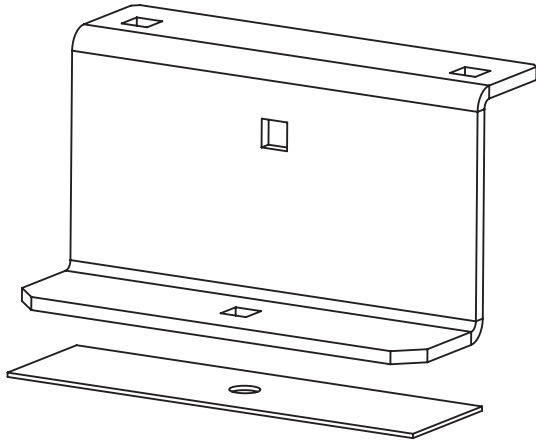

2.1 The following step is for vehicles with bolt through fixing points, if your vehicle has a t-rail please refer to step 2.2.

Secure the roof brackets to the fixing points using M6x25 coach bolts and secure under the roof using rubber washers, M6 washers & M6 serrated nuts. Ensure that the top hat flange is facing inwards. **If fitting a rear roller you must fit the roof brackets in the correct fixing positions, these are the first and fourth fixing points from the rear of the vehicle.**

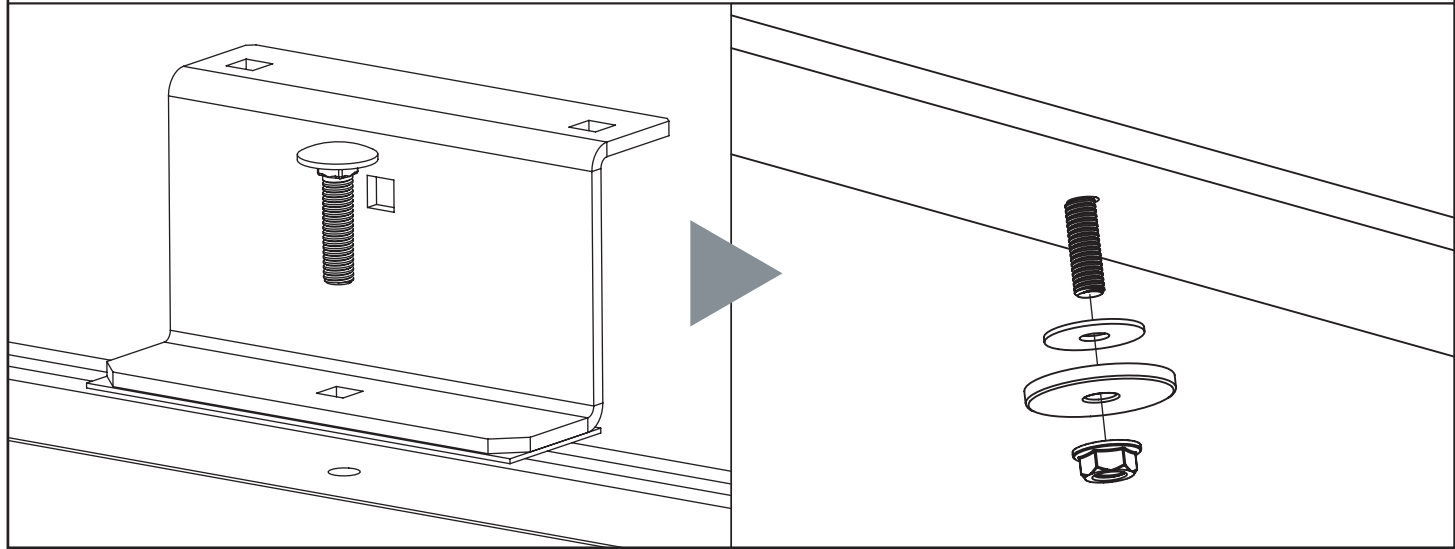

2.2 The following step is for vehicles with a t-rail, if your vehicle has bolt through fixing points please refer to step 2.1.

Secure the roof brackets to the vehicle as shown below using fixing plates, M6x25 coach bolts and M6 serrated nuts. Ensure that the top hat flange is facing inwards. **If fitting a rear roller you must fit the roof bars in the correct fixing positions, these are the first and fourth fixing points which fix the t-rail to the roof from the rear of the vehicle.**

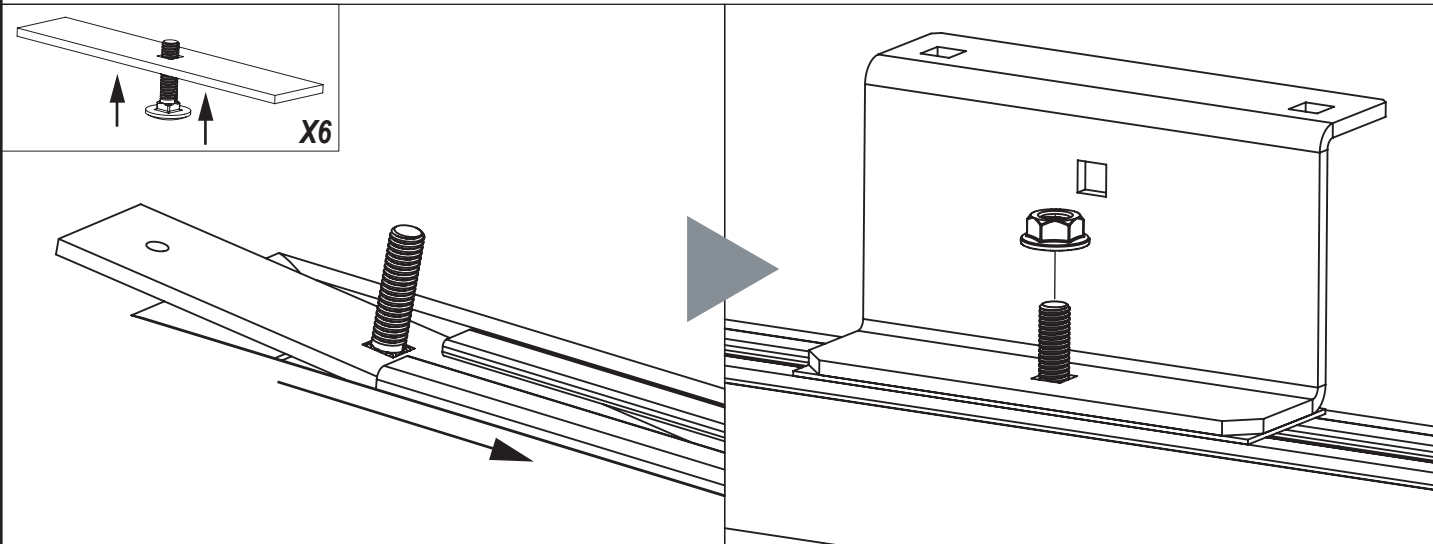

3 Place roof bars onto the roof brackets with the t-slot facing upwards, secure using top hat brackets, M6x16 coach bolts & M6 serrated nuts.

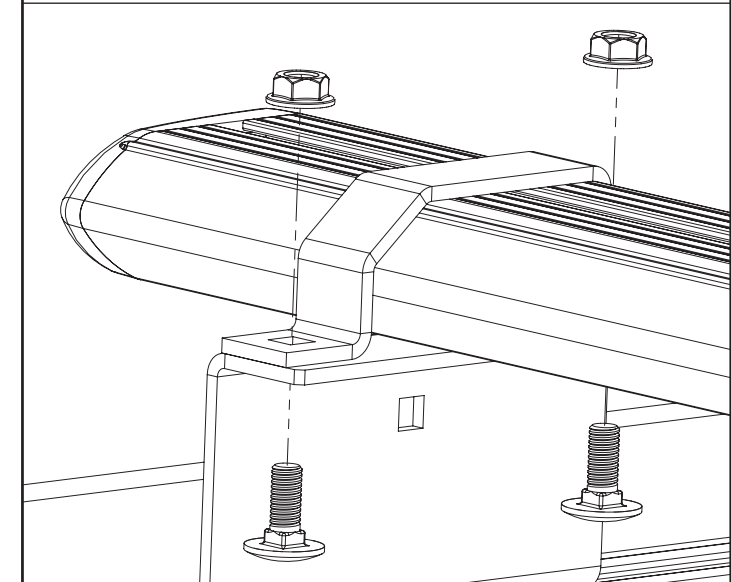

4

Flex the top hat covers over the top hat brackets into position as shown below. Ensure that the covers click into the front and rear of the top hat brackets.

1.

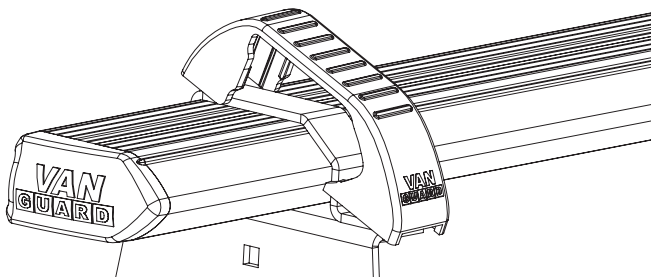

2.

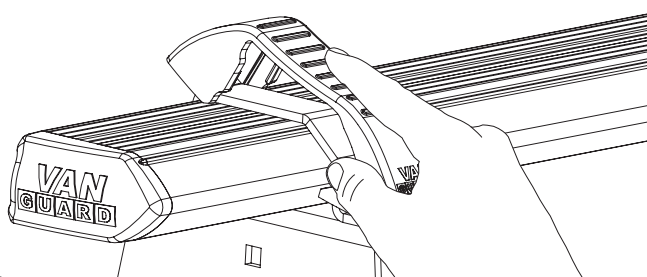

3.

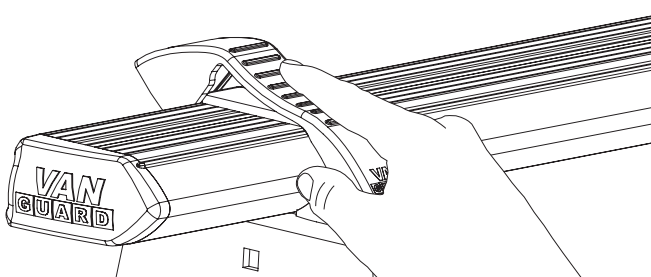

4.

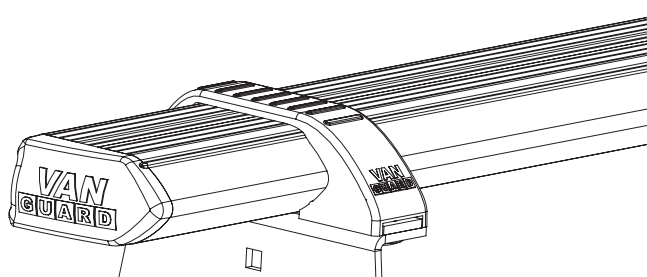
**5**

Once in position tighten all fixings to 8Nm. Periodically check all fixings.



**TIGHTEN
TO
8Nm**

NOTES:

Maximum load is 55kg per bar. Please check that the vehicle manufacturers load bearing capacity for the roof is not exceeded. (Refer to the vehicle handbook)

Periodically check all fixings.

Retain these instructions for future reference.

VAN

GUARD