

INSTRUCTION MANUAL

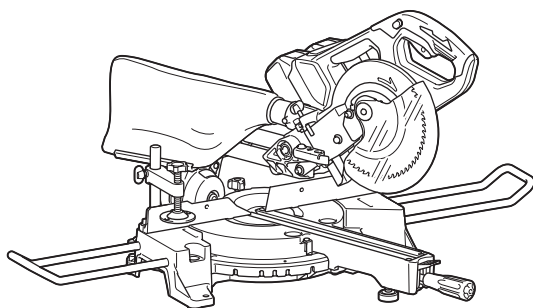

Cordless Slide Compound Miter Saw

DLS714



Read before use.

SPECIFICATIONS

Model:	DLS714	
Blade diameter	190 mm	
Blade body thickness	1.3 mm - 2.0 mm	
Hole (arbor) diameter (country specific)	20 mm or 15.88 mm	
Max. miter angle	Left 47°, Right 57°	
Max. bevel angle	Left 45°, Right 5°	
No load speed	5,700 min ⁻¹	
Dimensions (L x W x H)	655 mm x 430 mm x 445 mm	
Rated voltage	D.C.36 V	
Battery cartridge	BL1815N, BL1820, BL1820B	BL1830, BL1840, BL1840B, BL1850, BL1850B
Net weight	13.0 kg	13.5 kg





Cutting capacities (H x W) with blade 190 mm in diameter

Miter angle	Bevel angle		
	45° (left)	0°	5° (right)
0°	40 mm x 300 mm	52 mm x 300 mm	40 mm x 300 mm
	45 mm x 265 mm (NOTE 1)	60 mm x 265 mm (NOTE 1)	–
45° (left and right)	40 mm x 212 mm	52 mm x 212 mm	–
	45 mm x 185 mm (NOTE 2)	60 mm x 185 mm (NOTE 2)	–
57° (right)	–	52 mm x 163 mm	–
	–	60 mm x 145 mm (NOTE 3)	–

1. Max. Cutting capacity when using a wood facing 20 mm thickness
 2. Max. Cutting capacity when using a wood facing 15 mm thickness
 3. Max. Cutting capacity when using a wood facing 10 mm thickness
- Due to our continuing program of research and development, the specifications herein are subject to change without notice.
 - Specifications and battery cartridge may differ from country to country.
 - Weight, with battery cartridge, according to EPTA-Procedure 01/2003

Symbols

The following show the symbols used for the equipment. Be sure that you understand their meaning before use.

	Read instruction manual.
	To avoid injury from flying debris, keep holding the saw head down, after making cuts, until the blade has come to a complete stop.
	When performing slide cut, first pull carriage fully and press down handle, then push carriage toward the guide fence.
	Do not place hand or fingers close to the blade.
	Always set SUB-FENCE to left position when performing left bevel cuts. Failure to do so may cause serious injury to operator.



Only for EU countries
Do not dispose of electric equipment or battery pack together with household waste material!
In observance of the European Directives, on Waste Electric and Electronic Equipment and Batteries and Accumulators and Waste Batteries and Accumulators and their implementation in accordance with national laws, electric equipment and batteries and battery pack(s) that have reached the end of their life must be collected separately and returned to an environmentally compatible recycling facility.

Intended use

The tool is intended for accurate straight and miter cutting in wood.

Noise

The typical A-weighted noise level determined according to EN61029:

Sound pressure level (L_{PA}) : 88 dB(A)

Sound power level (L_{WA}) : 97 dB (A)

Uncertainty (K) : 3 dB(A)

▲WARNING: Wear ear protection.

Vibration

The vibration total value (tri-axial vector sum) determined according to EN61029:

Vibration emission (a_h) : 2.5 m/s² or less

Uncertainty (K) : 1.5 m/s²

NOTE: The declared vibration emission value has been measured in accordance with the standard test method and may be used for comparing one tool with another.

NOTE: The declared vibration emission value may also be used in a preliminary assessment of exposure.

▲WARNING: The vibration emission during actual use of the power tool can differ from the declared emission value depending on the ways in which the tool is used.

▲WARNING: Be sure to identify safety measures to protect the operator that are based on an estimation of exposure in the actual conditions of use (taking account of all parts of the operating cycle such as the times when the tool is switched off and when it is running idle in addition to the trigger time).

EC Declaration of Conformity

For European countries only

Makita declares that the following Machine(s):

Designation of Machine: Cordless Slide Compound Miter Saw

Model No./ Type: DLS714

Conforms to the following European Directives:

2006/42/EC

They are manufactured in accordance with the following standard or standardized documents: EN61029

The technical file in accordance with 2006/42/EC is available from:

Makita, Jan-Baptist Vinkstraat 2, 3070, Belgium
16.1.2015



Yasushi Fukaya

Director

Makita, Jan-Baptist Vinkstraat 2, 3070, Belgium

General power tool safety warnings

▲WARNING: Read all safety warnings and all instructions. Failure to follow the warnings and instructions may result in electric shock, fire and/or serious injury.

Save all warnings and instructions for future reference.

The term "power tool" in the warnings refers to your mains-operated (corded) power tool or battery-operated (cordless) power tool.

Work area safety

1. **Keep work area clean and well lit.** Cluttered or dark areas invite accidents.

2. **Do not operate power tools in explosive atmospheres, such as in the presence of flammable liquids, gases or dust.** Power tools create sparks which may ignite the dust or fumes.
3. **Keep children and bystanders away while operating a power tool.** Distractions can cause you to lose control.

Electrical Safety

1. **Power tool plugs must match the outlet. Never modify the plug in any way. Do not use any adapter plugs with earthed (grounded) power tools.** Unmodified plugs and matching outlets will reduce risk of electric shock.
2. **Avoid body contact with earthed or grounded surfaces such as pipes, radiators, ranges and refrigerators.** There is an increased risk of electric shock if your body is earthed or grounded.
3. **Do not expose power tools to rain or wet conditions.** Water entering a power tool will increase the risk of electric shock.
4. **Do not abuse the cord. Never use the cord for carrying, pulling or unplugging the power tool. Keep cord away from heat, oil, sharp edges or moving parts.** Damaged or entangled cords increase the risk of electric shock.
5. **When operating a power tool outdoors, use an extension cord suitable for outdoor use.** Use of a cord suitable for outdoor use reduces the risk of electric shock.
6. **If operating a power tool in a damp location is unavoidable, use a residual current device (RCD) protected supply.** Use of an RCD reduces the risk of electric shock.

Personal Safety

1. **Stay alert, watch what you are doing and use common sense when operating a power tool. Do not use a power tool while you are tired or under the influence of drugs, alcohol or medication.** A moment of inattention while operating power tools may result in serious personal injury.
2. **Use personal protective equipment. Always wear eye protection.** Protective equipment such as dust mask, non-skid safety shoes, hard hat, or hearing protection used for appropriate conditions will reduce personal injuries.
3. **Prevent unintentional starting. Ensure the switch is in the off-position before connecting to power source and/or battery pack, picking up or carrying the tool.** Carrying power tools with your finger on the switch or energising power tools that have the switch on invites accidents.
4. **Remove any adjusting key or wrench before turning the power tool on.** A wrench or a key left attached to a rotating part of the power tool may result in personal injury.
5. **Do not overreach. Keep proper footing and balance at all times.** This enables better control of the power tool in unexpected situations.
6. **Dress properly. Do not wear loose clothing or jewellery. Keep your hair, clothing, and gloves away from moving parts.** Loose clothes, jewellery or long hair can be caught in moving parts.
7. **If devices are provided for the connection of dust extraction and collection facilities, ensure these are connected and properly used.** Use of dust collection can reduce dust-related hazards.

Power tool use and care

1. **Do not force the power tool. Use the correct power tool for your application.** The correct power tool will do the job better and safer at the rate for which it was designed.
2. **Do not use the power tool if the switch does not turn it on and off.** Any power tool that cannot be controlled with the switch is dangerous and must be repaired.
3. **Disconnect the plug from the power source and/or the battery pack from the power tool before making any adjustments, changing accessories, or storing power tools.** Such preventive safety measures reduce the risk of starting the power tool accidentally.
4. **Store idle power tools out of the reach of children and do not allow persons unfamiliar with the power tool or these instructions to operate the power tool.** Power tools are dangerous in the hands of untrained users.
5. **Maintain power tools. Check for misalignment or binding of moving parts, breakage of parts and any other condition that may affect the power tool's operation. If damaged, have the power tool repaired before use.** Many accidents are caused by poorly maintained power tools.
6. **Keep cutting tools sharp and clean.** Properly maintained cutting tools with sharp cutting edges are less likely to bind and are easier to control.
7. **Use the power tool, accessories and tool bits etc. in accordance with these instructions, taking into account the working conditions and the work to be performed.** Use of the power tool for operations different from those intended could result in a hazardous situation.

Battery tool use and care

1. **Recharge only with the charger specified by the manufacturer.** A charger that is suitable for one type of battery pack may create a risk of fire when used with another battery pack.
2. **Use power tools only with specifically designated battery packs.** Use of any other battery packs may create a risk of injury and fire.
3. **When battery pack is not in use, keep it away from other metal objects, like paper clips, coins, keys, nails, screws or other small metal objects, that can make a connection from one terminal to another.** Shorting the battery terminals together may cause burns or a fire.
4. **Under abusive conditions, liquid may be ejected from the battery; avoid contact. If contact accidentally occurs, flush with water. If liquid contacts eyes, additionally seek medical help.** Liquid ejected from the battery may cause irritation or burns.

Service

1. **Have your power tool serviced by a qualified repair person using only identical replacement parts.** This will ensure that the safety of the power tool is maintained.
2. **Follow instruction for lubricating and changing accessories.**
3. **Keep handles dry, clean and free from oil and grease.**

Cordless miter saw safety warnings

1. **Keep hands out of path of saw blade. Avoid contact with any coasting blade. It can still cause severe injury.**
2. **Check the saw blade carefully for cracks or deformation before operation. Replace damaged blades immediately.**
3. **Replace the kerf board when worn.**
4. **Use only saw blades specified by the manufacturer which conform to EN847-1.**
5. **Do not use saw blades manufactured from high speed steel.**
6. **Wear eye protection.**
7. **Wear hearing protection to reduce the risk of hearing loss.**
8. **Wear gloves for handling saw blade (saw blades shall be carried in a holder wherever practicable) and rough material.**
9. **Connect miter saws to a dust collecting device when sawing.**
10. **Select saw blades in relation to the material to be cut.**
11. **Do not use the saw to cut other than wood.**
12. **Always secure all moving portions before carrying the tool. When lifting or carrying the tool, do not use the guard as a carrying handle.**
13. **Do not operate saw without guards in place. Check blade guard for proper closing before each use. Do not operate saw if blade guard does not move freely and close instantly. Never clamp or tie the blade guard into the open position.**
14. **Keep the floor area free of loose material e.g. chips and cut-offs.**
15. **Use only saw blades that are marked with a maximum speed equal to or higher than the no load speed marked on the tool.**
16. **When the tool is fitted with a laser or LED, do not replace the laser or LED with a different type. Ask an authorized service center for repair.**
17. **Never remove any cut-offs or other parts of the workpiece from the cutting area whilst the tool is running with an unguarded saw blade.**
18. **Do not perform any operation freehand. The workpiece must be secured firmly against the turn base and guide fence with the vise during all operations. Never use your hand to secure the workpiece.**
19. **Ensure that the tool is stable before each cut.**
20. **Fix the tool to a work bench, if needed.**
21. **Support long workpieces with appropriate additional supports.**
22. **Never cut so small workpiece which cannot be securely held by the vise. Improperly held workpiece may cause kickback and serious personal injury.**
23. **Never reach around saw blade.**
24. **Turn off tool and wait for saw blade to stop before moving workpiece or changing settings.**
25. **Disconnect the plug from the power source and/or the battery pack from the power tool before changing blade or servicing.**
26. **Stopper pin which locks the cutter head down is for carrying and storage purposes only and not for any cutting operations.**

27. Do not use the tool in the presence of flammable liquids or gases. The electrical operation of the tool could create an explosion and fire when exposed to flammable liquids or gases.
28. Use only flanges specified for this tool.
29. Be careful not to damage the arbor, flanges (especially the installing surface) or bolt. Damage to these parts could result in blade breakage.
30. Make sure that the turn base is properly secured so it will not move during operation.
31. For your safety, remove the chips, small pieces, etc. from the table top before operation.
32. Avoid cutting nails. Inspect for and remove all nails from the workpiece before operation.
33. Make sure the shaft lock is released before the switch is turned on.
34. Be sure that the blade does not contact the turn base in the lowest position.
35. Hold the handle firmly. Be aware that the saw moves up or down slightly during start-up and stopping.
36. Make sure the blade is not contacting the workpiece before the switch is turned on.
37. Before using the tool on an actual workpiece, let it run for a while. Watch for vibration or wobbling that could indicate poor installation or a poorly balanced blade.
38. Wait until the blade attains full speed before cutting.
39. Stop operation immediately if you notice anything abnormal.
40. Do not attempt to lock the trigger in the on position.
41. Be alert at all times, especially during repetitive, monotonous operations. Do not be lulled into a false sense of security. Blades are extremely unforgiving.
42. Always use accessories recommended in this manual. Use of improper accessories such as abrasive wheels may cause an injury.
43. Take care when slotting.
44. Some dust created from operation contains chemicals known to cause cancer, birth defects or other reproductive harm. Some examples of these chemicals are:
 - lead from lead-based-painted material and,
 - arsenic and chromium from chemically-treated lumber.
 Your risk from these exposures varies, depending on how often you do this type of work. To reduce your exposure to these chemicals: work in a well ventilated area and work with approved safety equipment, such as those dust masks that are specially designed to filter out microscopic particles.
45. To reduce the emitted noise, always be sure that the blade is sharp and clean.
46. The operator is adequately trained in the use, adjustment and operation of the machine.

SAVE THESE INSTRUCTIONS.

▲WARNING: DO NOT let comfort or familiarity with product (gained from repeated use) replace strict adherence to safety rules for the subject product. MISUSE or failure to follow the safety rules stated in this instruction manual may cause serious personal injury.

Important safety instructions for battery cartridge

1. Before using battery cartridge, read all instructions and cautionary markings on (1) battery charger, (2) battery, and (3) product using battery.
2. Do not disassemble battery cartridge.
3. If operating time has become excessively shorter, stop operating immediately. It may result in a risk of overheating, possible burns and even an explosion.
4. If electrolyte gets into your eyes, rinse them out with clear water and seek medical attention right away. It may result in loss of your eyesight.
5. Do not short the battery cartridge:
 - (1) Do not touch the terminals with any conductive material.
 - (2) Avoid storing battery cartridge in a container with other metal objects such as nails, coins, etc.
 - (3) Do not expose battery cartridge to water or rain.
 A battery short can cause a large current flow, overheating, possible burns and even a breakdown.
6. Do not store the tool and battery cartridge in locations where the temperature may reach or exceed 50 °C (122 °F).
7. Do not incinerate the battery cartridge even if it is severely damaged or is completely worn out. The battery cartridge can explode in a fire.
8. Be careful not to drop or strike battery.
9. Do not use a damaged battery.
10. Follow your local regulations relating to disposal of battery.

SAVE THESE INSTRUCTIONS.

Tips for maintaining maximum battery life

1. Charge the battery cartridge before completely discharged. Always stop tool operation and charge the battery cartridge when you notice less tool power.
2. Never recharge a fully charged battery cartridge. Overcharging shortens the battery service life.
3. Charge the battery cartridge with room temperature at 10 °C - 40 °C (50 °F - 104 °F). Let a hot battery cartridge cool down before charging it.
4. Charge the battery cartridge if you do not use it for a long period (more than six months).

PARTS DESCRIPTION

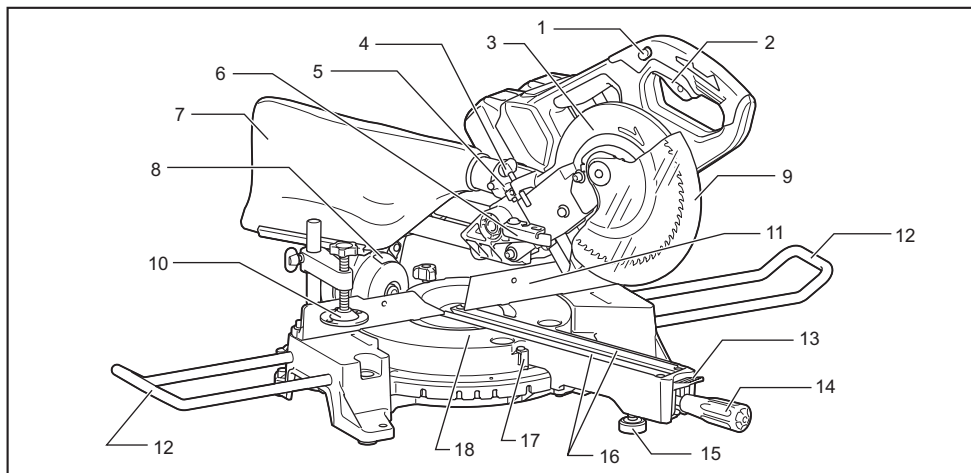

1	Lock-off button	2	Switch trigger	3	Blade case	4	Adjusting screw (for lower limit position)
5	Adjusting bolt (for maximum cutting capacity)	6	Stopper arm	7	Dust bag	8	Bevel scale
9	Blade guard	10	Vertical vice	11	Guide fence	12	Holder
13	Lock lever (for turn base)	14	Grip (for turn base)	15	Adjusting bolt (for turn base)	16	Kerf board
17	Pointer (for miter angle)	18	Turn base	-	-	-	-

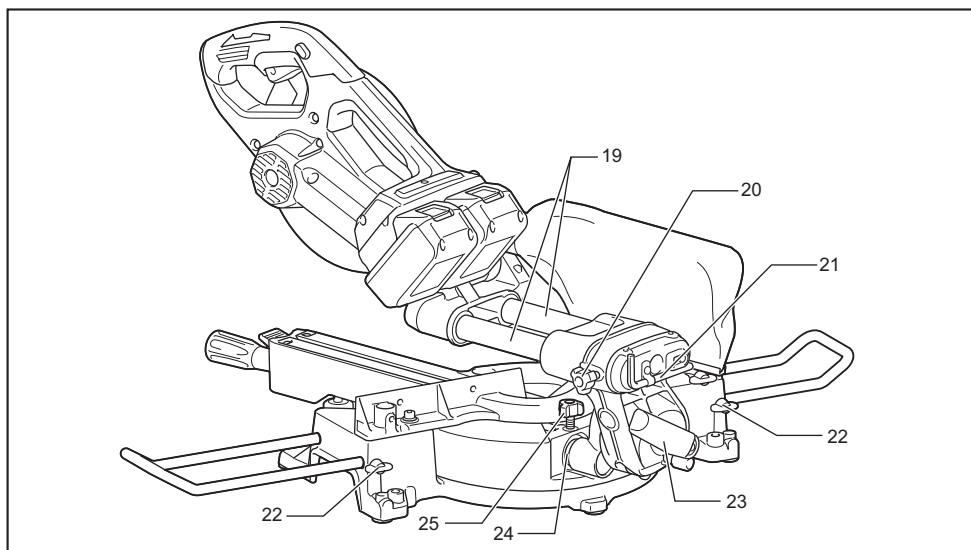

19	Slide pole (upper)	20	Thumb screw (for locking upper slide pole)	21	Hex wrench	22	Clamp screw (for locking holder)
23	Lever (for bevel angle adjustment)	24	Slide pole (lower)	25	Thumb screw (for locking lower slide pole)	-	-

INSTALLATION

Bench mounting

⚠WARNING: Ensure that the tool does not move on the supporting surface. Movement of the miter saw on the supporting surface while cutting may result in loss of control and serious personal injury.

1. Fix the base to a level and stable surface, screwing with two bolts. This helps to prevent from tipping and possible injury.

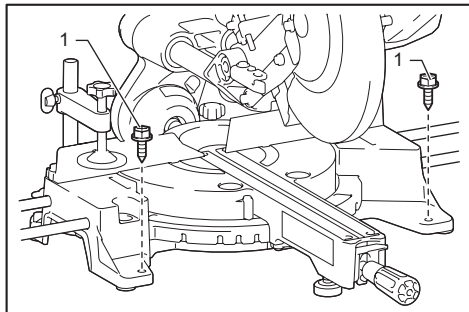

1. Bolt

2. Turn the adjusting bolt clockwise or counterclockwise so that it comes into a contact with the floor surface to keep the tool stable.

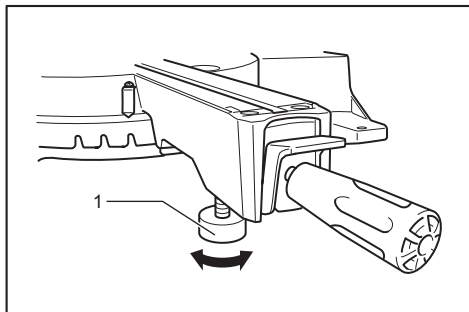

1. Adjusting bolt

FUNCTIONAL DESCRIPTION

⚠WARNING: Always be sure that the tool is switched off and the battery cartridge is removed before adjusting or checking the functions on the tool. Failure to switch off and remove the battery cartridge may result in serious personal injury from accidental start-up.

Installing or removing battery cartridge

⚠CAUTION: Always switch off the tool before installing or removing of the battery cartridge.

⚠CAUTION: Hold the tool and the battery cartridge firmly when installing or removing battery cartridge. Failure to hold the tool and the battery cartridge firmly may cause them to slip off your hands and result in damage to the tool and battery cartridge and a personal injury.

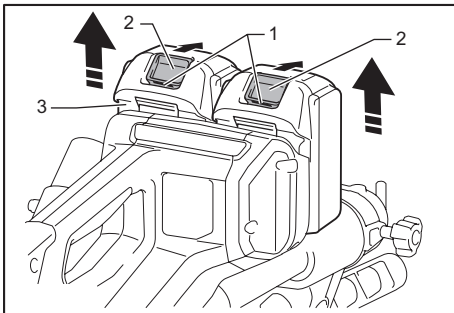

1. Red indicator 2. Button 3. Battery cartridge

To remove the battery cartridge, slide it from the tool while sliding the button on the front of the cartridge. To install the battery cartridge, align the tongue on the battery cartridge with the groove in the housing and slip it into place. Insert it all the way until it locks in place with a little click. If you can see the red indicator on the upper side of the button, it is not locked completely.

⚠CAUTION: Always install the battery cartridge fully until the red indicator cannot be seen. If not, it may accidentally fall out of the tool, causing injury to you or someone around you.

⚠CAUTION: Do not install the battery cartridge forcibly. If the cartridge does not slide in easily, it is not being inserted correctly.

NOTE: The tool does not work with only one battery cartridge.

Tool / battery protection system

The tool is equipped with a tool/battery protection system. This system automatically cuts off power to the motor to extend tool and battery life. The tool will automatically stop during operation if the tool or battery is placed under one of the following conditions. In some conditions, the indicators light up.

Overload protection

When the tool is operated in a manner that causes it to draw an abnormally high current, the tool automatically stops without any indication. In this situation, turn the tool off and stop the application that caused the tool to become overloaded. Then turn the tool on to restart.

Overheat protection

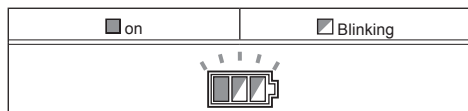

When the tool is overheated, the tool stops automatically, and the battery indicator blink about 60 seconds. In this situation, let the tool cool down before turning the tool on again.

Overdischarge protection

When the battery capacity becomes low, the tool stops automatically. If the product does not operate even when the switches are operated, remove the batteries from the tool and charge the batteries.

Indicating the remaining battery capacity

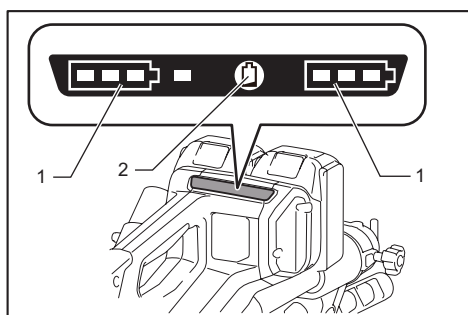

1. Battery indicator 2. Check button

Press the check button to indicate the remaining battery capacities. The battery indicators correspond to each battery.

Battery indicator status			Remaining battery capacity
On	Off	Blinking	
			50% - 100%
			20% - 50%
			0% - 20%
			Charge the battery

Indicating the remaining battery capacity

Only for battery cartridges with "B" at the end of the model number

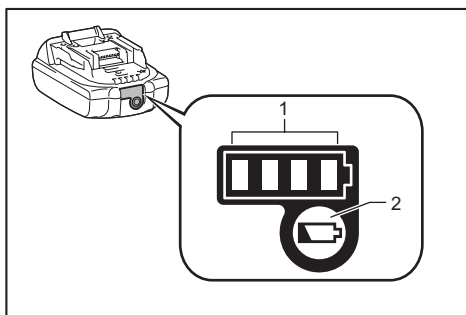

1. Indicator lamps 2. Check button

Press the check button on the battery cartridge to indicate the remaining battery capacity. The indicator lamps light up for few seconds.



Indicator lamps			Remaining capacity
Lighted	Off	Blinking	
			75% to 100%
			50% to 75%
			25% to 50%
			0% to 25%
			Charge the battery.
			The battery may have malfunctioned.

NOTE: Depending on the conditions of use and the ambient temperature, the indication may differ slightly from the actual capacity.

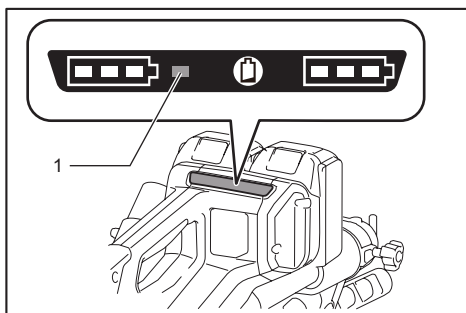
Automatic speed change function



1. Mode indicator

Mode indicator status	Operation mode
	High speed mode
	High torque mode

This tool has "high speed mode" and "high torque mode". It automatically changes operation mode depending on the work load. When mode indicator lights up during operation, the tool is in high torque mode.

Stopper pin

CAUTION: Always hold the handle when releasing the stopper pin. Otherwise the handle springs up and it may result in personal injury.

To release the stopper pin, keep applying a slight downward pressure on the handle and then pulling the stopper pin.

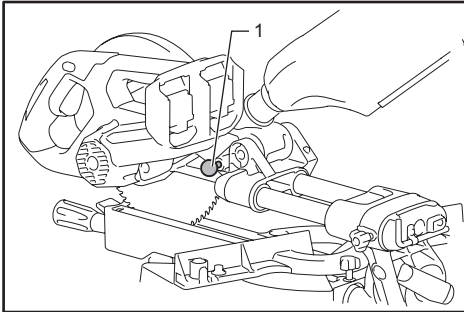

1. Stopper pin

Blade guard

WARNING: Never defeat or remove the blade guard or the spring which attaches to the guard. An exposed blade as a result of defeated guarding may result in serious personal injury during operation.

WARNING: Never use the tool if the blade guard or spring are damaged, faulty or removed. Operation of the tool with a damaged, faulty or removed guard may result in serious personal injury.

CAUTION: Always maintain the blade guard in good condition for safe operation. Stop the operation immediately if there are any irregularity of the blade guard. Check to assure spring loaded return action of guard.

For tools with blade guard release lever

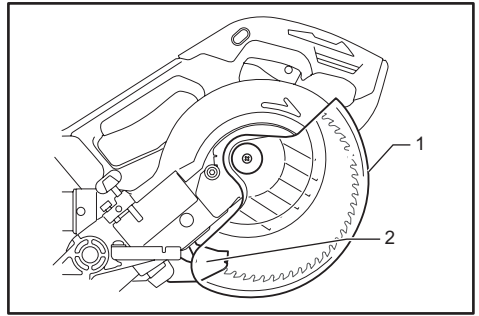

1. Blade guard A 2. Blade guard B

When lowering the handle, the blade guard A rises automatically. The blade guard B rises as it contacts a workpiece. The guards are spring loaded so it returns to its original position when the cut is completed and the handle is raised.

For tools without blade guard release lever

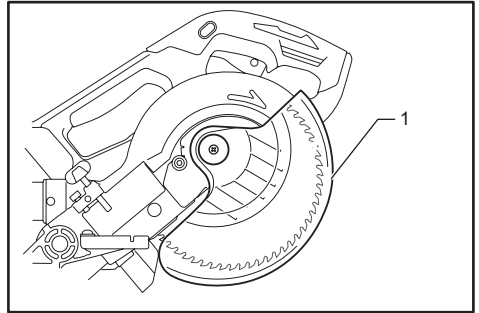

1. Blade guard

When lowering the handle, the blade guard raises automatically. The guard is spring loaded so it returns to its original position when the cut is completed and the handle is raised.

Cleaning

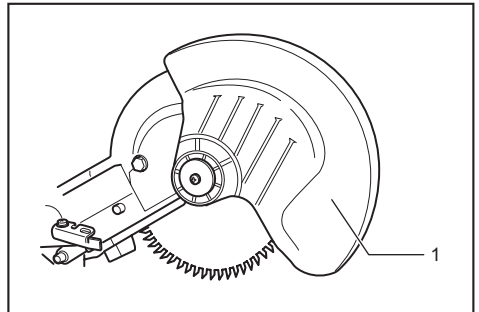

1. Blade guard

If the transparent blade guard becomes dirty, or sawdust adheres to it in such a way that the blade and/or workpiece is no longer easily visible, remove the battery cartridge and clean the guard carefully with a damp cloth. Do not use solvents or any petroleum-based

cleaners on the plastic guard because this may cause damage to the guard.

For cleaning, raise the blade guard by referring to "Installing or removing saw blade".

After cleaning, make sure to return the blade and center cover and tighten the hex socket bolt.

1. Make sure that the tool is switched off and the battery cartridges are removed.
2. Turn the hex socket bolt counterclockwise using the supplied hex wrench with holding the center cover.
3. Raise the blade guard and center cover.
4. When cleaning is complete, return the center cover and tighten the hex socket bolt by performing the steps above in reverse.

⚠WARNING: Do not remove spring holding blade guard. If guard becomes damaged in course of time or UV light exposure, contact a Makita service center for replacement. **DO NOT DEFEAT OR REMOVE GUARD.**

Positioning kerf board

This tool is provided with the kerf boards in the turn base to minimize tearing on the exit side of a cut. The kerf boards are factory adjusted so that the saw blade does not contact the kerf boards. Before use, adjust the kerf boards as follows:

1. Make sure to remove the battery cartridge. Then, loosen all the screws (2 each on left and right) securing the kerf boards.

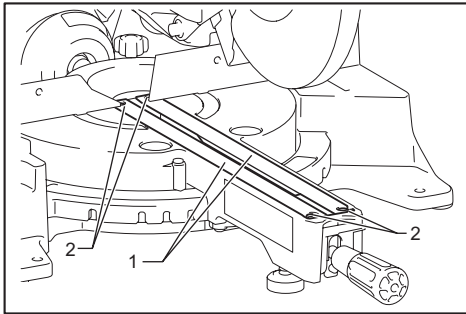

1. Kerf board 2. Screw

2. Re-tighten them only to the extent that the kerf boards can still be easily moved by hand.
3. Lower the handle fully and push in the stopper pin to lock the handle in the lowered position.
4. Loosen two clamp screws which secure the slide poles.

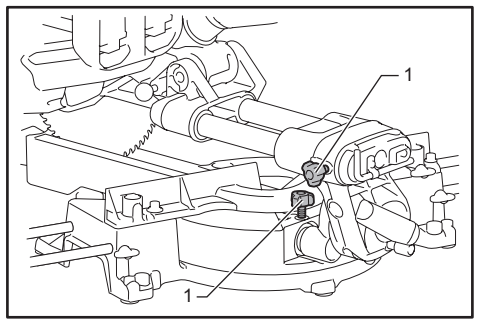

1. Thumb screw

5. Pull the carriage toward you fully.
6. Adjust the kerf boards so that the kerf boards just contact the sides of the blade teeth.

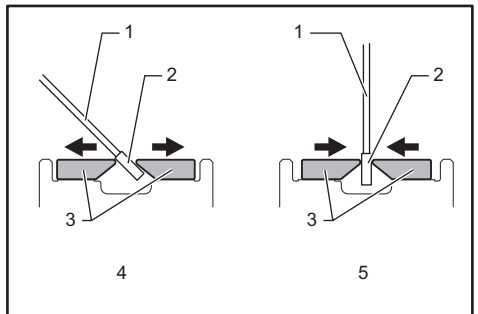
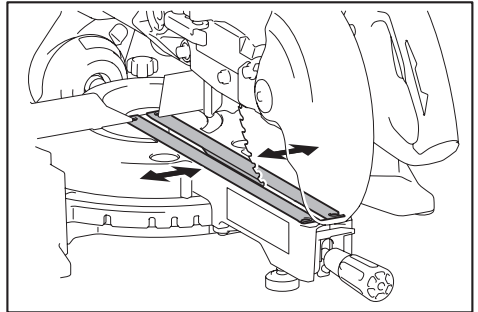

1. Saw blade 2. Blade teeth 3. Kerf board
4. Left bevel cut 5. Straight cut

7. Tighten the front screws (do not tighten firmly).
8. Push the carriage toward the guide fence fully and adjust the kerf boards so that the kerf boards just contact the sides of blade teeth.
9. Tighten the rear screws (do not tighten firmly).
10. After adjusting the kerf boards, release the stopper pin and raise the handle. Then tighten all the screws securely.

NOTICE: After setting the bevel angle ensure that the kerf boards are adjusted properly. Correct adjustment of the kerf boards helps to provide proper support of the workpiece and minimizing workpiece tear out.

Maintaining maximum cutting capacity

This tool is factory adjusted to provide the maximum cutting capacity for a 190 mm saw blade. When installing a new blade, always check the lower limit position of the blade, and if necessary, adjust it as follows:

1. Remove the battery cartridge. Then, push the carriage toward the guide fence fully and lower the handle completely.

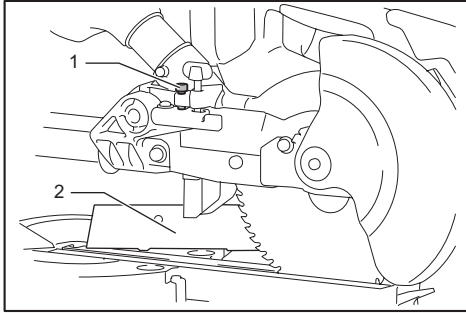

1. Adjusting bolt 2. Guide fence

2. Use the hex wrench to turn the adjusting bolt until the saw blade comes slightly below the cross section of the guide fence and the top surface of the turn base.

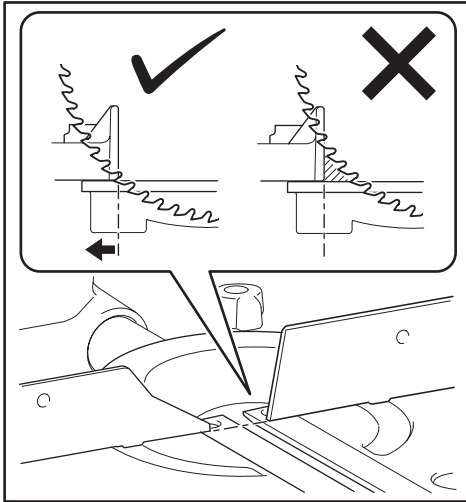

3. Rotate the blade by hand while holding the handle all the way down to be sure that the blade does not contact any part of the lower base. Re-adjust slightly, if necessary.

⚠WARNING: After installing a new blade and with the battery cartridge removed, always be sure that the blade does not contact any part of the lower base when the handle is lowered completely. If a blade makes contact with the base it may cause kickback and result in serious personal injury.

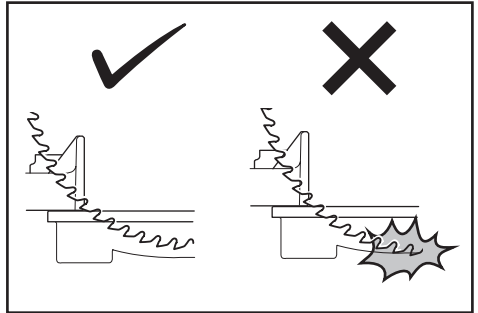

Stopper arm

The lower limit position of the blade can be easily adjusted with the stopper arm. To adjust it, move the stopper arm in the direction of the arrow as shown in the figure. Turn the adjusting screw and press down the handle fully to check the result.

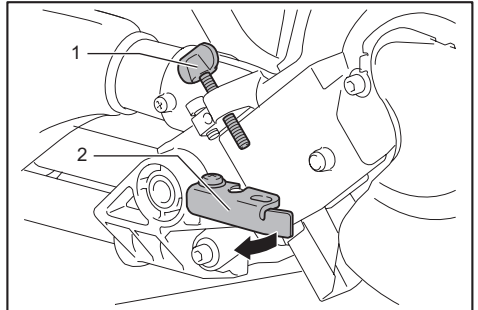

1. Adjusting screw 2. Stopper arm

Sub-fence

Country specific

⚠CAUTION: When performing left bevel cuts, flip the sub-fence outward. Otherwise, it may contact the blade or a part of the tool, and may result in serious injury to the operator.

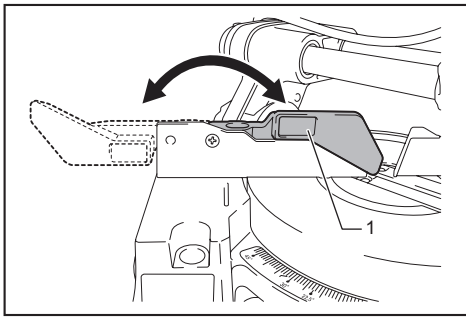

1. Sub-fence

This tool is equipped with the sub-fence. Usually position the sub-fence inside. However, when performing left bevel cuts, flip it outward.

Adjusting the miter angle

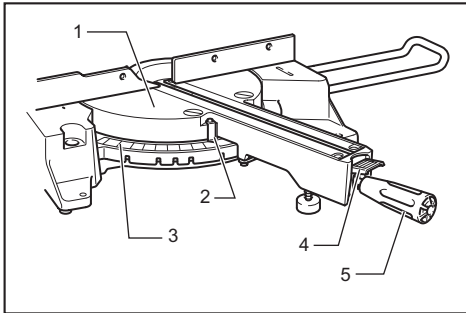

1. Turn base 2. Pointer 3. Miter scale 4. Lock lever 5. Grip

1. Loosen the grip counterclockwise.
2. Press down and hold the lock lever, and adjust the angle of the turn base. Use the pointer and the miter scale as a guide.
3. Tighten the grip clockwise firmly.

CAUTION: After changing the miter angle, always secure the turn base by tightening the grip firmly.

NOTICE: When turning the turn base, be sure to raise the handle fully.

Adjusting the bevel angle

To adjust the bevel angle, loosen the lever at the rear of the tool counterclockwise.

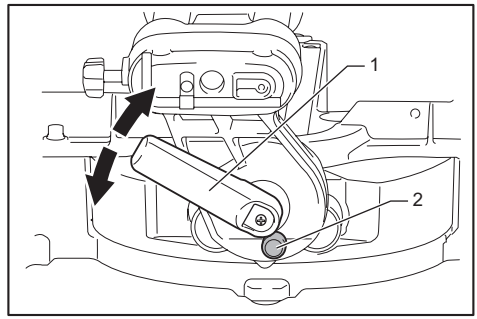

1. Lever 2. Release button

To tilt the blade to the left, hold the handle and tilt the carriage. Use the bevel scale and the pointer as a guide. Then tighten the lever clockwise firmly to secure the arm.

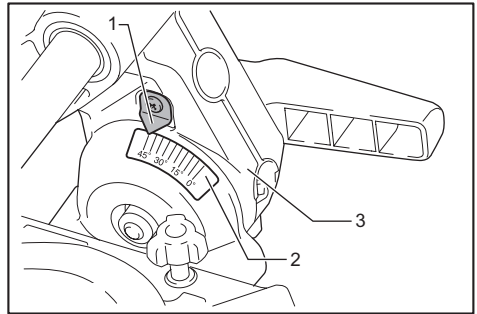

1. Pointer 2. Bevel scale 3. Arm

To tilt the blade to the right, hold the handle and tilt the carriage to the left slightly, and push the release button. With the release button pressed, tilt the saw blade to the right. Then tighten the lever.

CAUTION: After changing the bevel angle, always secure the arm by tightening the lever clockwise.

NOTICE: When tilting the saw blade be sure the handle is fully raised.

NOTICE: When changing bevel angles, be sure to position the kerf boards appropriately as explained in the "Positioning kerf boards" section.

Adjusting the lever position

If the lever does not provide full tightening in course of time, change the position of the lever. The lever can be repositioned at every 30° angle.

Loosen and remove the screw that secures the lever. Remove the lever and install it again so that it points slightly above the horizontal. Then, tighten the lever with the screw firmly.

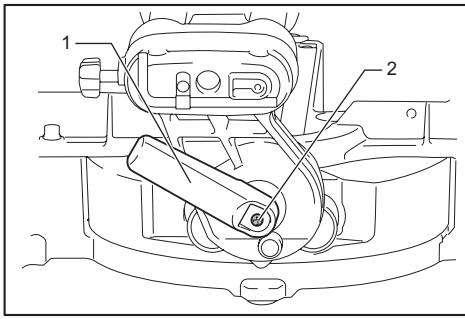

1. Lever 2. Screw

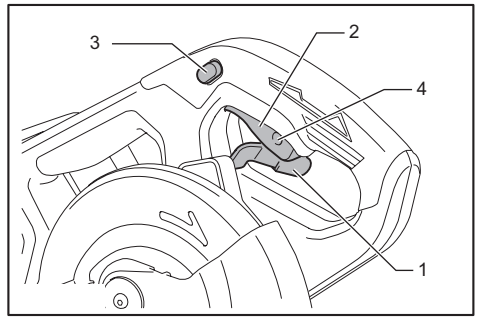

1. Blade guard release lever 2. Switch trigger
3. Lock-off button 4. Hole for padlock

Switch action

⚠WARNING: Before installing the battery cartridge on the tool, always check to see that the switch trigger actuates properly and returns to the "OFF" position when released. Operating a tool with a switch that does not actuate properly can lead to loss of control and serious personal injury.

⚠WARNING: Do not use a lock with a shank or cable any smaller than 6.35 mm (1/4") in diameter. A smaller shank or cable may not properly lock the tool in the off position and unintentional operation may occur resulting in serious personal injury.

⚠WARNING: NEVER use tool without a fully operative switch trigger. Any tool with an inoperative switch is HIGHLY DANGEROUS and must be repaired before further usage or serious personal injury may occur.

⚠WARNING: For your safety, this tool is equipped with a lock-off button which prevents the tool from unintended starting. NEVER use the tool if it runs when you simply pull the switch trigger without pressing the lock-off button. A switch in need of repair may result in unintentional operation and serious personal injury. Return tool to a Makita service center for proper repairs BEFORE further usage.

⚠WARNING: NEVER defeat the lock-off button by taping down or some other means. A switch with a negated lock-off button may result in unintentional operation and serious personal injury.

NOTICE: Do not pull the switch trigger hard without pressing in the lock-off button. This can cause switch breakage.

For tools with blade guard release lever

To prevent the switch trigger from being accidentally pulled, a lock-off button is provided. To start the tool, push the blade guard release lever up, press in the lock-off button and then pull the switch trigger. Release the switch trigger to stop.

The lock-off button can be pressed from either right or left.

A hole is provided in the switch trigger for insertion of a padlock to lock the tool off.

For tools without blade guard release lever

To prevent the switch trigger from being accidentally pulled, a lock-off button is provided. To start the tool, press in the lock-off button and pull the switch trigger. Release the switch trigger to stop.

The lock-off button can be pressed from either right or left.

A hole is provided in the switch trigger for insertion of a padlock to lock the tool off.

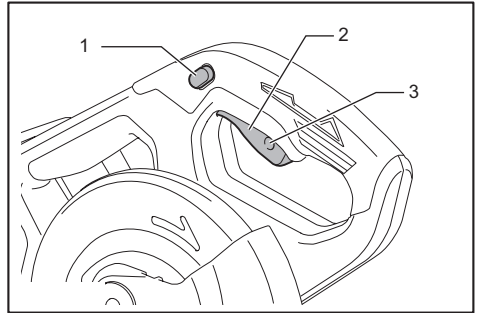

1. Lock-off button 2. Switch trigger 3. Hole for padlock

ASSEMBLY

⚠WARNING: Always be sure that the tool is switched off and the battery cartridge is removed before working on the tool. Failure to switch off and remove the battery cartridge may result in serious personal injury.

Hex wrench storage

The hex wrench is stored as shown in the figure. When the hex wrench is needed it can be pulled out of the wrench holder.

After using the hex wrench it can be stored by returning it to the wrench holder.

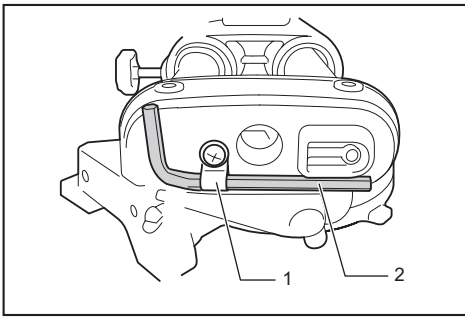

1. Wrench holder 2. Hex wrench

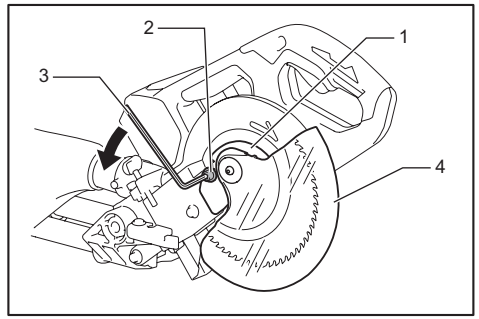

1. Center cover 2. Hex socket bolt 3. Hex wrench
4. Blade guard

Installing or removing saw blade

⚠WARNING: Always be sure that the tool is switched off and the battery cartridge is removed before installing or removing the blade. Accidental start up of the tool may result in serious personal injury.

⚠CAUTION: Use only the Makita hex wrench provided to install or remove the blade. Failure to do so may result in overtightening or insufficient tightening of the hex socket bolt. This could cause an injury.

To remove the blade, perform the following steps:

1. Lock the handle in the raised position by pushing in the stopper pin.

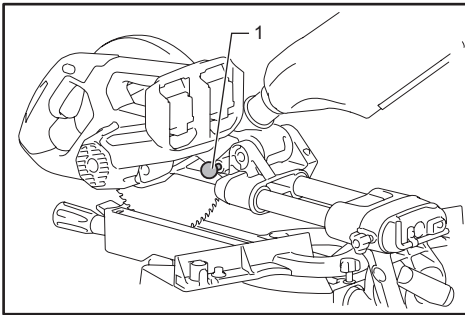

1. Stopper pin

2. Use the hex wrench to loosen the hex socket bolt holding the center cover by turning it counterclockwise. Then, raise the blade guard and center cover.

3. Press the shaft lock to lock the spindle and use the hex wrench to loosen the hex socket bolt clockwise. Then remove the hex socket bolt of the spindle, outer flange and blade.

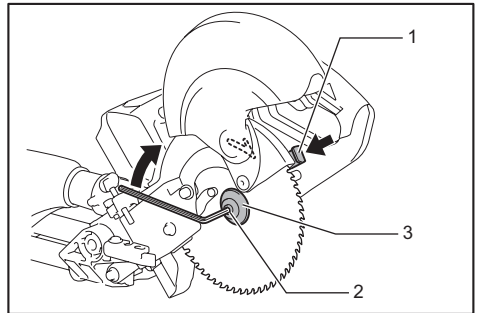

1. Shaft lock 2. Hex socket bolt 3. Outer flange

4. If the inner flange is removed, install it on the spindle with its blade mounting part facing the blade. If the flange is installed incorrectly the flange will rub against the machine.

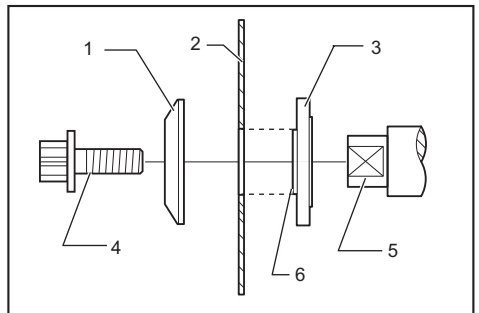

1. Outer flange 2. Saw blade 3. Inner flange
4. Hex socket bolt (left-handed) 5. Spindle
6. Blade mounting part

To install the blade, perform the following steps:

1. Mount the blade carefully onto the inner flange. Make sure that the direction of the arrow on the blade matches the direction of the arrow on the blade case.

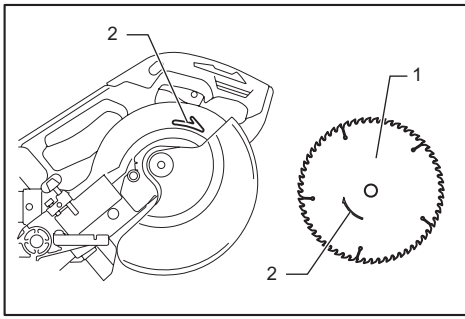

1. Saw blade 2. Arrow

2. Install the outer flange and hex socket bolt, and then use the hex wrench to tighten the hex socket bolt (left-handed) of the spindle securely counterclockwise while pressing the shaft lock.
3. Return the blade guard and center cover to its original position. Then tighten the hex socket bolt of the center cover clockwise to secure the center cover.
4. Release the handle from the raised position by pulling the stopper pin. Lower the handle to make sure that the blade guard moves properly.
5. Make sure the shaft lock has released spindle before making cut.

For tool with the inner flange for 15.88 mm hole-diameter saw blade

Country specific

Mount the blade carefully onto the spindle.

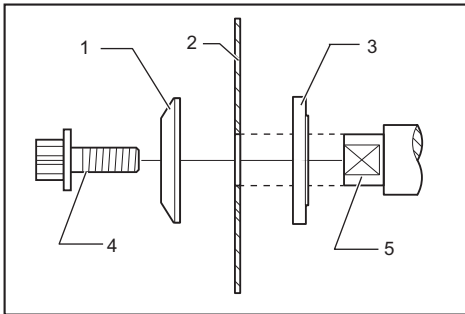

1. Outer flange 2. Saw blade 3. Inner flange
4. Hex socket bolt (left-handed) 5. Spindle

For tool with the inner flange for other than 20 mm or 15.88 mm hole-diameter saw blade

Country specific

The inner flange has a certain diameter of a blade mounting part on one side of it and a different diameter of blade mounting part on the other side. Choose a correct side on which blade mounting part fits into the saw blade hole perfectly.

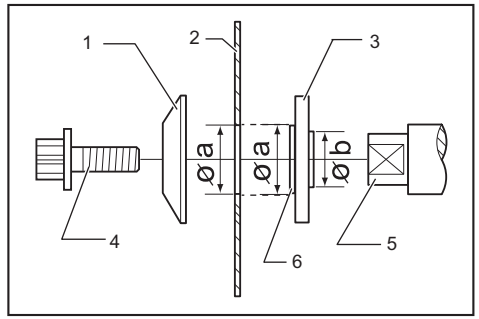

1. Outer flange 2. Saw blade 3. Inner flange
4. Hex socket bolt (left-handed) 5. Spindle
6. Blade mounting part

CAUTION: Make sure that the blade mounting part "a" on the inner flange that is positioned outside fits into the saw blade hole "a" perfectly. Mounting the blade on the wrong side can result in the dangerous vibration.

Dust bag

Optional accessory

The use of the dust bag makes cutting operations cleaner and dust collection easier.

To attach the dust bag, fit it onto the dust nozzle.

To attach the fastener, align the top end of the fastener with the triangular mark on the dust bag.

When the dust bag is about half full, remove the dust bag from the tool and pull the fastener out. Empty the dust bag of its contents, tapping it lightly so as to remove particles adhering to the insides which might hamper further collection.

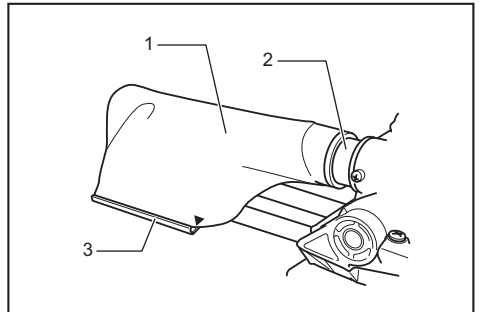

1. Dust bag 2. Dust nozzle 3. Fastener

NOTE: If you connect a vacuum cleaner to your saw, cleaner operations can be performed.

Securing workpiece

⚠WARNING: It is extremely important to always secure the workpiece correctly with the proper type of vise. Failure to do so may result in serious personal injury and cause damage to the tool and/or the workpiece.

⚠WARNING: When cutting a workpiece that is longer than the support base of the saw, support the entire length of the material beyond the support base and at the same height to keep the material level. Proper workpiece support helps to avoid blade pinch and possible kickback which may result in serious personal injury. Do not rely solely on the vertical vise and/or horizontal vise to secure the workpiece. Thin material tends to sag. Support workpiece over its entire length to avoid blade pinch and possible KICKBACK.

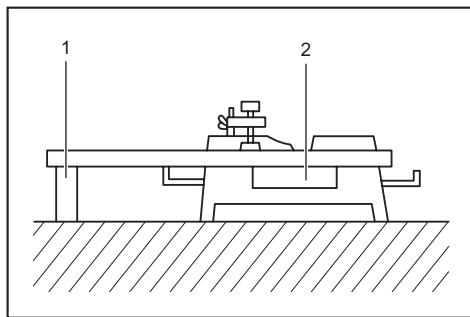

1. Support 2. Turn base

Vertical vise

⚠WARNING: Secure the workpiece firmly against the turn base and guide fence with the vise during all operations. Otherwise the material may move during the cutting operation, cause damage to the blade, and be thrown which may result in loss of control and serious personal injury.

Install the vertical vise on either the left or right side of the guide fence or the holder assembly (optional accessory). Insert the vise rod into the hole in the guide fence or the holder assembly and tighten the lower screw to secure the vise rod.

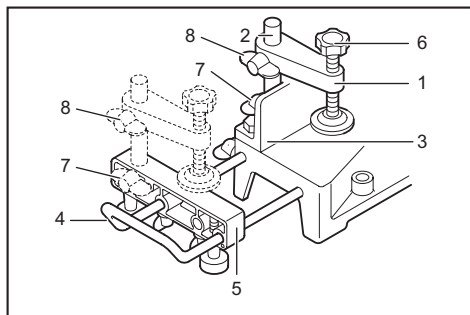

1. Vise arm
2. Vise rod
3. Guide fence
4. Holder
5. Holder assembly
6. Vise knob
7. Lower screw
8. Upper screw

Position the vise arm according to the thickness and shape of the workpiece and secure the vise arm by tightening the upper screw. If the upper screw contacts the guide fence, install the upper screw on the opposite side of vise arm. Make sure that no part of the tool contacts the vise when lowering the handle fully and pulling or pushing the carriage all the way. If some part contacts the vise, re-position the vise. Press the workpiece flat against the guide fence and the turn base. Position the workpiece at the desired cutting position and secure it firmly by tightening the vise knob.

Horizontal vise

Optional accessory

⚠WARNING: Grip the workpiece only when the indicator is at the topmost position. Failure to do so may result in insufficient securing of the workpiece. This may cause the workpiece to be thrown, cause damage to the blade or cause the loss of control, which may result in personal injury.

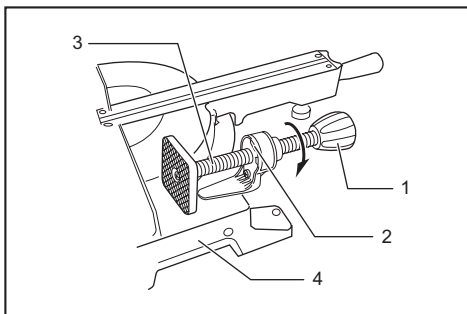

1. Vise knob 2. Indicator 3. Vise shaft
4. Base

The horizontal vise can be installed on the left side of the base.

By turning the vise knob counterclockwise, the screw is released and the vise shaft can be moved rapidly in and out. By turning the vise knob clockwise, the screw remains secured.

To grip the workpiece, turn the vise knob gently clockwise until the indicator reaches its topmost position, then fasten securely. If the vise knob is forced in or pulled out while being turned clockwise, the indicator may stop at an angle. In this case, turn the vise knob back counterclockwise until the screw is released, and then turn it again gently clockwise.

The maximum capacity of the horizontal vise is 120 mm width.

Holders and holder assembly

Optional accessory

⚠WARNING: Always support a long workpiece so it is level with the top surface of the turn base for an accurate cut and to prevent dangerous loss of tool control. Proper workpiece support helps to avoid blade pinch and possible kickback which may result in serious personal injury.

The holders and the holder assembly (optional accessory) can be installed on either side as a convenient means of supporting workpieces horizontally. Install them on the side of the tool, then tighten the screws firmly to secure them.

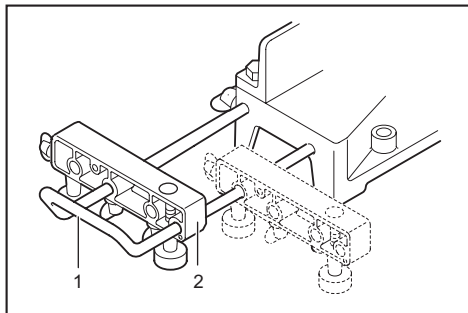

1. Holder 2. Holder assembly

When cutting long workpieces, use the holder-rod assembly (optional accessory). It consists of two holder assemblies and two rods 12.

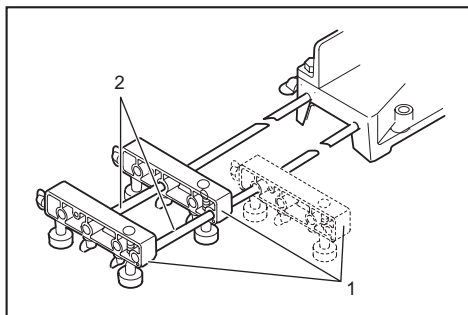

1. Holder assembly 2. Rod 12

OPERATION

⚠WARNING: Make sure the blade is not contacting the workpiece, etc. before the switch is turned on. Turning the tool on with the blade in contact with the workpiece may result in kickback and serious personal injury.

⚠WARNING: After a cutting operation, do not raise the blade until it has come to a complete stop. The raising of a coasting blade may result in serious personal injury and damage to the workpiece.

⚠WARNING: Do not touch the clamp screws which secure the slide poles while the saw blade is rotating. Otherwise the tool may lose control and result in personal injury.

NOTICE: Before use, be sure to release the handle from the lowered position by pulling the stopper pin.

NOTICE: Do not apply excessive pressure on the handle when cutting. Too much force may result in overload of the motor and/or decreased cutting efficiency. Press down handle with only as much force as necessary for smooth cutting and without significant decrease in blade speed.

NOTICE: Gently press down the handle to perform the cut. If the handle is pressed down with force or if lateral force is applied, the blade may vibrate and leave a mark (saw mark) in the workpiece and the precision of the cut may be impaired.

NOTICE: During a slide cut, gently push the carriage toward the guide fence without stopping. If the carriage movement stops during the cut, a mark may be left in the workpiece and the precision of the cut may be impaired.

Press cutting (cutting small workpieces)

⚠WARNING: Firmly tighten two clamp screws which secure the slide poles clockwise so that the carriage will not move during operation. Insufficient tightening of the locking screw may cause possible kickback which may result in serious personal injury.

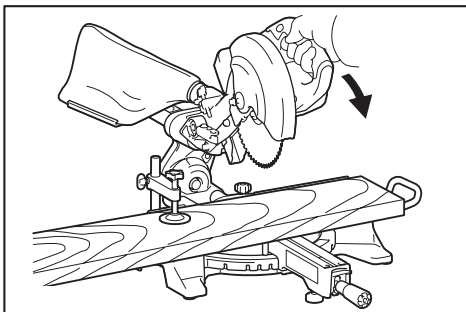

Workpieces up to 52 mm high and 97 mm wide can be cut in the following manner.

1. Push the carriage toward the guide fence fully and tighten two clamp screws which secure the slide poles counterclockwise to secure the carriage.
2. Secure the workpiece with the proper type of vise.
3. Switch on the tool without the blade making any contact and wait until the blade attains full speed before lowering.
4. Gently lower the handle to the fully lowered position to cut the workpiece.
5. When the cut is completed, switch off the tool and wait until the blade has come to a complete stop before returning the blade to its fully elevated position.

Slide (push) cutting (cutting wide workpieces)

▲WARNING: Whenever performing a slide cut, first pull the carriage full towards you and press the handle all the way down, then push the carriage toward the guide fence. Never start the cut with the carriage not pulled fully toward you. If you perform the slide cut without the carriage pulled fully toward you unexpected kickback may occur and serious personal injury may result.

▲WARNING: Never attempt to perform a slide cut by pulling the carriage towards you. Pulling the carriage towards you while cutting may cause unexpected kickback resulting in possible serious personal injury.

▲WARNING: Never perform the slide cut with the handle locked in the lowered position.

▲WARNING: Never loosen the knob which secures the carriage while the blade is rotating. A loose carriage while cutting may cause unexpected kickback resulting in possible serious personal injury.

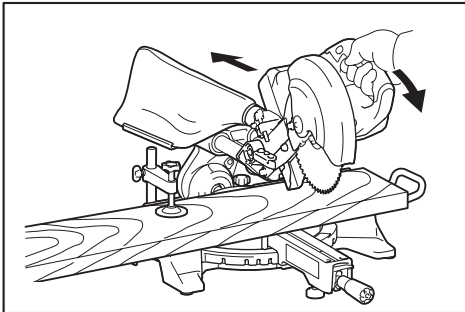

1. Loosen two clamp screws which secure the slide poles counterclockwise so that the carriage can slide freely.
2. Secure the workpiece with the proper type of vise.
3. Pull the carriage toward you fully.
4. Switch on the tool without the blade making any contact and wait until the blade attains full speed.
5. Press the handle down and push the carriage toward the guide fence and through the workpiece.

6. When the cut is completed, switch off the tool and wait until the blade has come to a complete stop before returning the blade to its fully elevated position.

Miter cutting

Refer to the previously covered "Adjusting the miter angle".

Bevel cut

▲WARNING: After setting the blade for a bevel cut, before operating the tool ensure that the carriage and blade will have free travel throughout the entire range of the intended cut. Interruption of the carriage or blade travel during the cutting operation may result in kickback and serious personal injury.

▲WARNING: While making a bevel cut keep hands out of the path of the blade. The angle of the blade may confuse the operator as to the actual blade path while cutting and contact with the blade will result in serious personal injury.

▲WARNING: The blade should not be raised until it has come to a complete stop. During a bevel cut the piece cut off may come to rest against the blade. If the blade is raised while it is rotating the cut-off piece maybe ejected by the blade causing the material to fragment which may result in serious personal injury.

▲CAUTION: (Only for tools with sub-fence)
Always set the sub-fence outside when performing left bevel cuts.

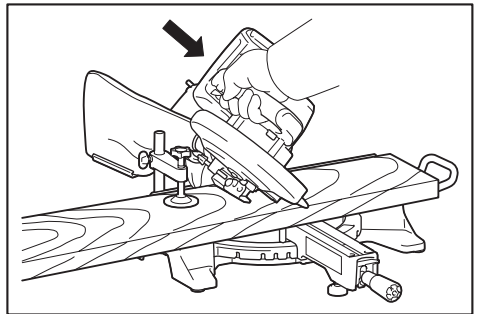

1. Loosen the lever and tilt the saw blade to set the bevel angle (Refer to the previously covered "Adjusting the bevel angle"). Be sure to retighten the lever firmly to secure the selected bevel angle safely.
2. Secure the workpiece with a vise.
3. Pull the carriage toward you fully.
4. Switch on the tool without the blade making any contact and wait until the blade attains full speed.
5. Gently lower the handle to the fully lowered position while applying pressure in parallel with the blade and push the carriage toward the guide fence to cut the workpiece.

6. When the cut is completed, switch off the tool and **wait until the blade has come to a complete stop** before returning the blade to its fully elevated position.

NOTICE: When pressing down the handle, apply pressure in parallel with the blade. If a force is applied perpendicularly to the turn base or if the pressure direction is changed during a cut, the precision of the cut will be impaired.

Compound cutting

Compound cutting is the process in which a bevel angle is made at the same time in which a miter angle is being cut on a workpiece. Compound cutting can be performed at the angle shown in the table.

Miter angle	Bevel angle
Left and Right 45°	Left 0° - 45°
Right 50°	Left 0° - 40°
Right 55°	Left 0° - 30°
Right 57°	Left 0° - 25°

When performing compound cutting, refer to "Press cutting", "Slide cutting", "Miter cutting" and "Bevel cut" explanations.

Cutting crown and cove moldings

Crown and cove moldings can be cut on a compound miter saw with the moldings laid flat on the turn base. There are two common types of crown moldings and one type of cove moldings; 52/38° wall angle crown molding, 45° wall angle crown molding and 45° wall angle cove molding.

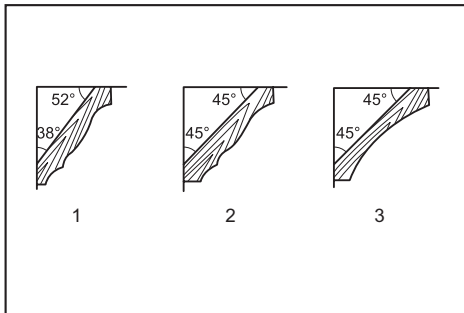

1. 52/38° type crown molding 2. 45° type crown molding 3. 45° type cove molding

There are crown and cove molding joints which are made to fit "Inside" 90° corners ((a) and (b) in the figure) and "Outside" 90° corners ((c) and (d) in the figure.)

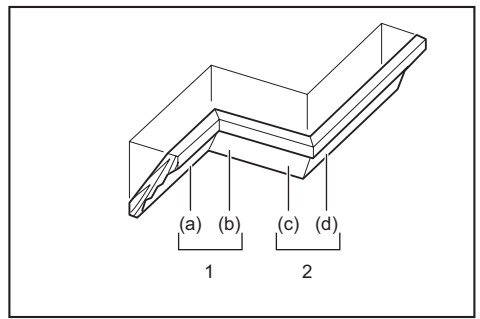

1. Inside corner 2. Outside corner

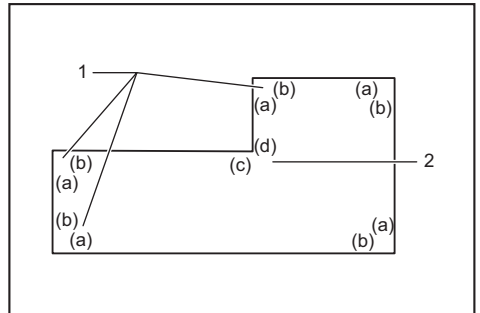

1. Inside corner 2. Outside corner

Measuring

Measure the wall width, and adjust the width of the workpiece according to it. Always make sure that width of the workpiece's wall contact edge is the same as wall length.

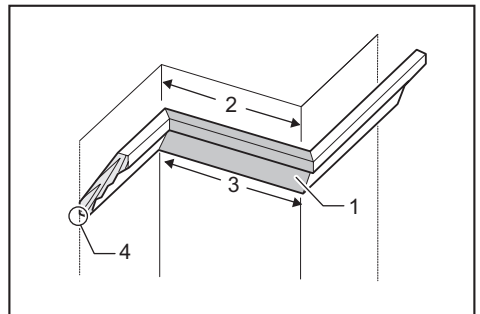

1. Workpiece 2. Wall width 3. Width of the workpiece 4. Wall contact edge

Always use several pieces for test cuts to check the saw angles.

When cutting crown and cove moldings, set the bevel angle and miter angle as indicated in the table (A) and position the moldings on the top surface of the saw base as indicated in the table (B).

In the case of left bevel cut

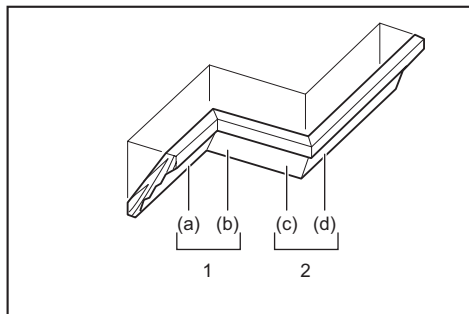

1. Inside corner 2. Outside corner

Table (A)

-	Molding position in the figure	Bevel angle		Miter angle	
		52/38° type	45° type	52/38° type	45° type
For inside corner	(a)	Left 33.9°	Left 30°	Right 31.6°	Right 35.3°
	(b)			Left 31.6°	Left 35.3°
For outside corner	(c)			Right 31.6°	Right 35.3°
	(d)				

Table (B)

-	Molding position in the figure	Molding edge against guide fence	Finished piece
For inside corner	(a)	Ceiling contact edge should be against guide fence.	Finished piece will be on the Left side of blade.
	(b)	Wall contact edge should be against guide fence.	
For outside corner	(c)	Wall contact edge should be against guide fence.	Finished piece will be on the Right side of blade.
	(d)	Ceiling contact edge should be against guide fence.	

Example:

In the case of cutting 52/38° type crown molding for position (a) in the above figure:

- Tilt and secure bevel angle setting to 33.9° LEFT.
- Adjust and secure miter angle setting to 31.6° RIGHT.
- Lay crown molding with its broad back (hidden) surface down on the turn base with its CEILING CONTACT EDGE against the guide fence on the saw.
- The finished piece to be used will always be on the LEFT side of the blade after the cut has been made.

Wood facing

⚠WARNING: Use screws to attach the wood facing to the guide fence. The screws should be installed so that the screw heads are below the surface of the wood facing so that they will not interfere with the positioning of the material being cut. Misalignment of the material being cut can cause unexpected movement during the cutting operation which may result in a loss of control and serious personal injury.

⚠CAUTION: Use the straight wood of even thickness as the wood facing.

Use of wood facing helps to assure splinter-free cuts in workpieces. Attach a wood facing to the guide fence using the holes in the guide fence.

See the figure concerning the dimensions for a suggested wood facing.

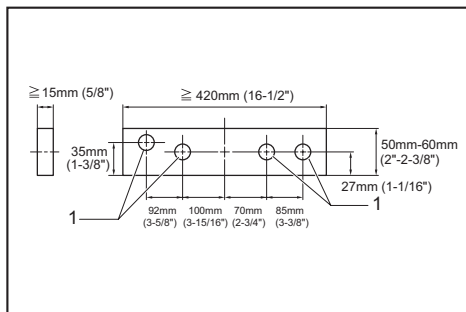

1. Holes

NOTICE: When the wood facing is attached, do not turn the turn base with the handle lowered. The blade and/or the wood facing will be damaged.

Cutting repetitive lengths

When cutting several pieces of stock to the same length, ranging from 220 mm to 385 mm, use the set plate (optional accessory). Install the set plate on the holder (optional accessory) as shown in the figure.

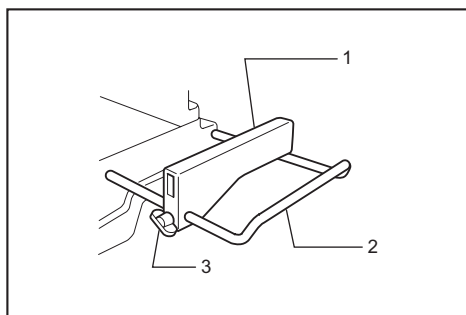

1. Set plate 2. Holder 3. Screw

Align the cutting line on your workpiece with either the left or right side of the groove in the kerf board, and

while holding the workpiece, move the set plate flush against the end of the workpiece. Then secure the set plate with the screw.

When the set plate is not used, loosen the screw and turn the set plate out of the way.

NOTE: Use of the holder-rod assembly (optional accessory) allows cutting repetitive lengths up to 2,200 mm approximately.

Groove cutting

⚠WARNING: Do not attempt to perform this type of cut by using a wider type blade or dado blade. Attempting to make a groove cut with a wider blade or dado blade could lead to unexpected cutting results and kickback which may result in serious personal injury.

⚠WARNING: Be sure to return the stopper arm to the original position when performing other than groove cutting. Attempting to make cuts with the stopper arm in the incorrect position could lead to unexpected cutting results and kickback which may result in serious personal injury.

For a dado type cut, perform as follows:

1. Adjust the lower limit position of the blade using the adjusting screw and the stopper arm to limit the cutting depth of the blade. Refer to "Stopper arm" section described on previously.
2. After adjusting the lower limit position of the blade, cut parallel grooves across the width of the workpiece using a slide (push) cut.

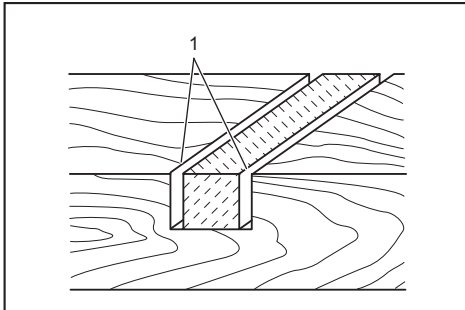

1. Cut grooves with blade

3. Remove the workpiece material between the grooves with a chisel.

Carrying tool

⚠WARNING: Stopper pin is only for carrying and storage purposes and should never be used for any cutting operations. The use of the stopper pin for cutting operations may cause unexpected movement of the saw blade resulting in kickback and serious personal injury.

⚠CAUTION: Always secure all moving portions before carrying the tool. If portions of the tool move or slide while being carried loss of control or balance may occur resulting in personal injury.

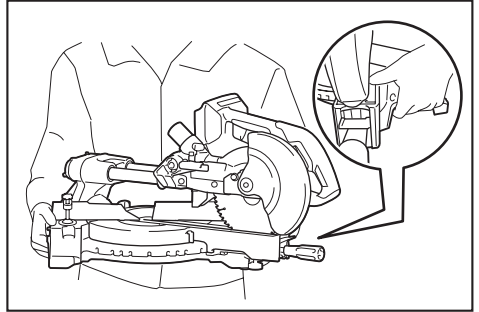

1. Remove the battery cartridge.
2. Secure the blade at 0° bevel angle and the turn base at the full right miter angle position.
3. Secure the slide poles so that the lower slide pole is locked in the position of the carriage fully pulled to operator and the upper poles are locked in the position of the carriage fully pushed forward to the guide fence.
4. Lower the handle fully and lock it in the lowered position by pushing in the stopper pin.
5. Carry the tool by holding both sides of the tool base. If you remove the holders, dust bag, etc., you can carry the tool more easily.

MAINTENANCE

⚠WARNING: Always be sure that the blade is sharp and clean for the best and safest performance. Attempting a cut with a dull and /or dirty blade may cause kickback and result in a serious personal injury.

⚠CAUTION: Always be sure that the tool is switched off and the battery cartridge is removed before attempting to perform inspection or maintenance.

NOTICE: Never use gasoline, benzine, thinner, alcohol or the like. Discoloration, deformation or cracks may result.

Adjusting the cutting angle

This tool is carefully adjusted and aligned at the factory, but rough handling may have affected the alignment. If your tool is not aligned properly, perform the following:

Miter angle

1. Push the carriage toward the guide fence and tighten two clamp screws to secure the carriage.
2. Rotate the turn base until the pointer indicates 0° on the miter scale.

3. Rotate the turn base slightly clockwise and counterclockwise to seat the turn base in the 0° miter notch. (Leave as it is if the pointer does not indicate 0°.)

4. Loosen the hex socket bolt securing the guide fence using the hex wrench.

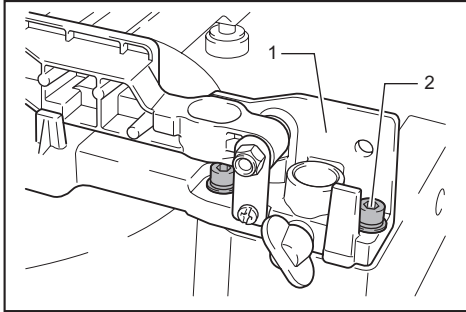

1. Guide fence 2. Hex socket bolt

5. Lower the handle fully and lock it in the lowered position by pushing in the stopper pin.

6. Adjust the guide fence until it makes a perpendicular angle with the blade using a triangular rule, try-square, etc. Then securely tighten the hex socket bolt on the guide fence in order starting from the right side.

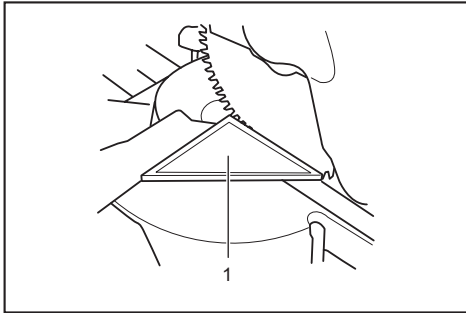

1. Triangular rule

7. Make sure that the pointer indicates 0° on the miter scale. If the pointer does not indicate 0°, loosen the screw which secures the pointer and adjust the pointer so that it indicates 0°.

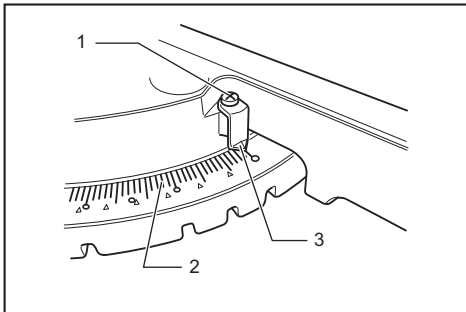

1. Screw 2. Miter scale 3. Pointer

Bevel angle

0° bevel angle

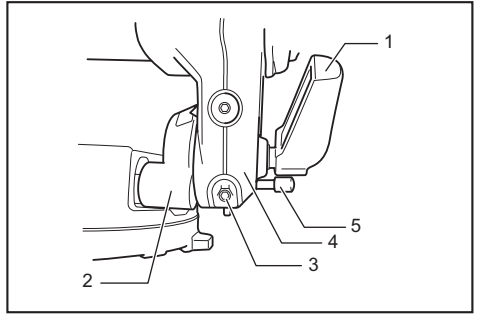

1. Lever 2. Arm holder 3. 0° degree bevel angle adjusting bolt 4. Arm 5. Release button

1. Push the carriage toward the guide fence and tighten two clamp screws to secure the carriage.

2. Lower the handle fully and lock it in the lowered position by pushing in the stopper pin.

3. Loosen the lever at the rear of the tool.

4. Turn the 0° bevel angle adjusting bolt (lower bolt) on the right side of the arm two or three revolutions counterclockwise to tilt the blade to the right.

5. Turn the 0° bevel angle adjusting bolt clockwise carefully until the side of the blade makes a perpendicular angle with the top surface of the turn base. Use the triangular rule, try-square, etc. as a guide. Then tighten the lever securely.

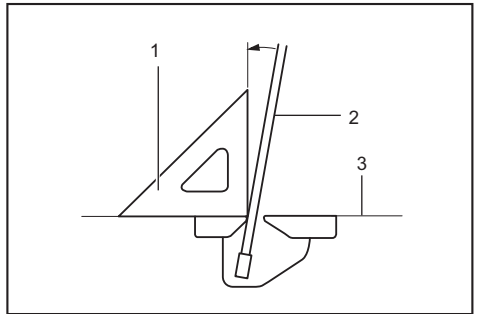

1. Triangular rule 2. Saw blade 3. Top surface of turn table

6. Make sure that the pointer on the arm indicates 0° on the bevel scale. If it does not indicate 0°, loosen the screw which secures the pointer and adjust the pointer so that it indicates 0°.

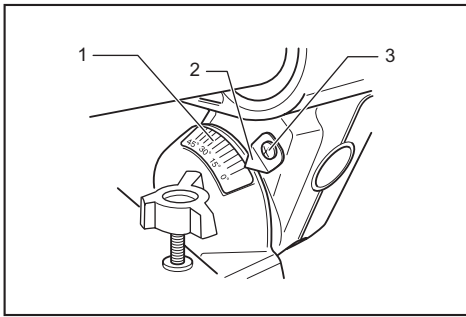

1. Bevel scale 2. Pointer 3. Screw

45° bevel angle

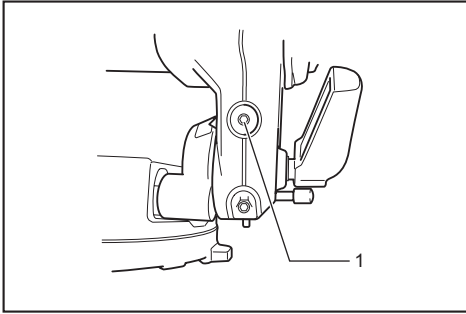

1. Left 45° bevel angle adjusting bolt

Adjust the 45° bevel angle only after performing 0° bevel angle adjustment.

1. Loosen the lever and tilt the blade to the left fully.
2. Make sure that the pointer on the arm indicates 45° on the bevel scale. If the pointer does not indicate 45°, turn the 45° bevel angle adjusting bolt (upper bolt) on the right side of the arm until the pointer indicates 45°.

After use

After use, wipe off chips and dust adhering to the tool with a cloth or the like. Keep the blade guard clean according to the directions in the previously covered section titled "Blade guard". Lubricate the sliding portions with machine oil to prevent rust.

When storing the tool, pull the carriage toward you fully so that the slide pole is thoroughly inserted into the turn base.

To maintain product SAFETY and RELIABILITY, repairs, any other maintenance or adjustment should be performed by Makita Authorized or Factory Service Centers, always using Makita replacement parts.

OPTIONAL ACCESSORIES

▲WARNING: These Makita accessories or attachments are recommended for use with your Makita tool specified in this manual. The use of any other accessories or attachments may result in serious personal injury.

▲WARNING: Only use the Makita accessory or attachment for its stated purpose. Misuse of an accessory or attachment may result in serious personal injury.

If you need any assistance for more details regarding these accessories, ask your local Makita Service Center.

- Carbide-tipped saw blades
- Vise assembly (Horizontal vise)
- Vertical vise
- Holder assembly
- Holder rod assembly
- Set plate
- Dust bag
- Triangular rule
- Hex wrench
- Makita genuine battery and charger

NOTE: Some items in the list may be included in the tool package as standard accessories. They may differ from country to country.

Makita Jan-Baptist Vinkstraat 2, 3070, Belgium
Makita Corporation Anjo, Aichi, Japan

www.makita.com

885417-222

EN
20150413