

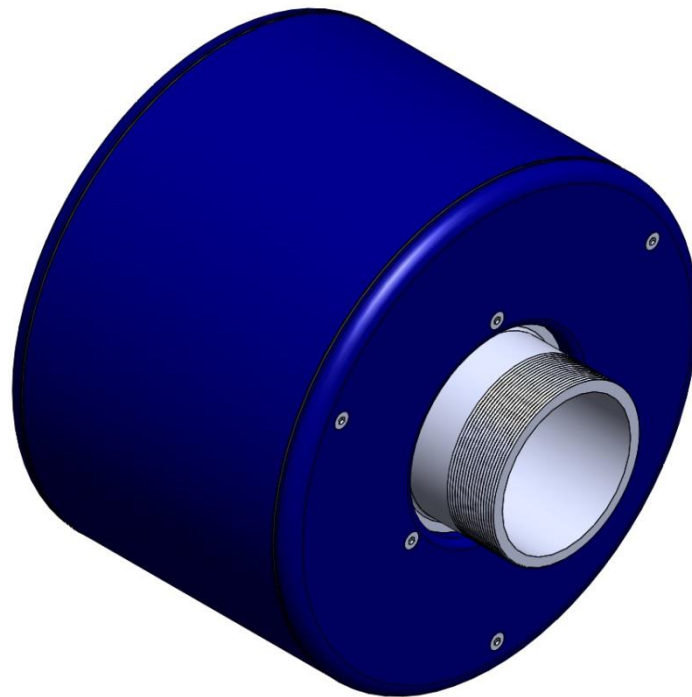

Installation & Operating Instruction Manual



Contents

1. General Notes	3
2. Installation	4
3. Electrical Notes.....	7
4. Troubleshooting Guide	9
5. Spare Parts List.....	9
6. Specifications	10
7. Warranty Information	11

1. General Notes

Powermag is a WRAS approved electromagnetic physical water conditioner that utilises a powerful electromagnetic field to inhibit hard crystalline scale formation in hot and cold water systems. The Powermag induces a specific magnetic field within the water path that has a physical effect on the hardness minerals within the water supply. This helps to inhibit new formations and remove existing formations of scale, providing an environmentally friendly method of scale treatment without the use of chemicals.

The Powermag physical water conditioner alters the structure of scale forming particles encouraging them to pass through the pipe system without leaving deposits of hard scale within the system. The Powermag physical water conditioner does not introduce sodium, or any other chemicals, into the water and therefore the water remains potable.

Physically conditioned water will tend to revert back to its untreated state over time; we recommend the sooner that the water is used after treatment, the more effective the physical water conditioner will be. In addition consideration should be given where water turbulence may be induced in the water flow as this may reduce the effectiveness of the physical water conditioner. Please refer to the installation section of this manual for guidance on the optimum position for treatment of the water supply.

The Powermag does not require a separate drain. It can be installed directly in-line without the need for water bypass. There are no moving parts so the device requires minimal servicing.

2. Installation

Powermag must be installed by a professional installer

The device should be installed directly in-line on pipework in any of the following materials; stainless steel, galvanized steel, copper or plastic.

To ensure that the device is adequately supported and does not place excessive strain on the existing pipework, we recommend using additional support brackets (not supplied) on the inlet and outlet pipework. The device can be installed in either vertical or horizontal orientation to suit your existing pipework and while it may be necessary to install additional pipework, elbows and fittings in order to adequately locate the device we recommend keeping this to a minimum.

The device is manufactured from stainless steel tubing and as such is resistant to corrosion.

We recommend the use of isolation valves before and after the device to facilitate any service or maintenance work that may be required.

The Powermag control panel should be connected to a suitable 13A fused switched spur. Please refer to the product specification data to ensure you have a suitable spur available.

The spur must incorporate an accessible isolation switch to enable maintenance or repair of the device.

Under no circumstances should the Powermag coil assembly be connected directly to any mains power supply. Always connect the coil assembly to the control panel supplied with the device.

Recommended Installations

Powermag units are best installed in one of the following positions:

- Gravity feed from a central water tank
- After a booster pump
- Directly on the cold mains supply, where all outlets are mains fed

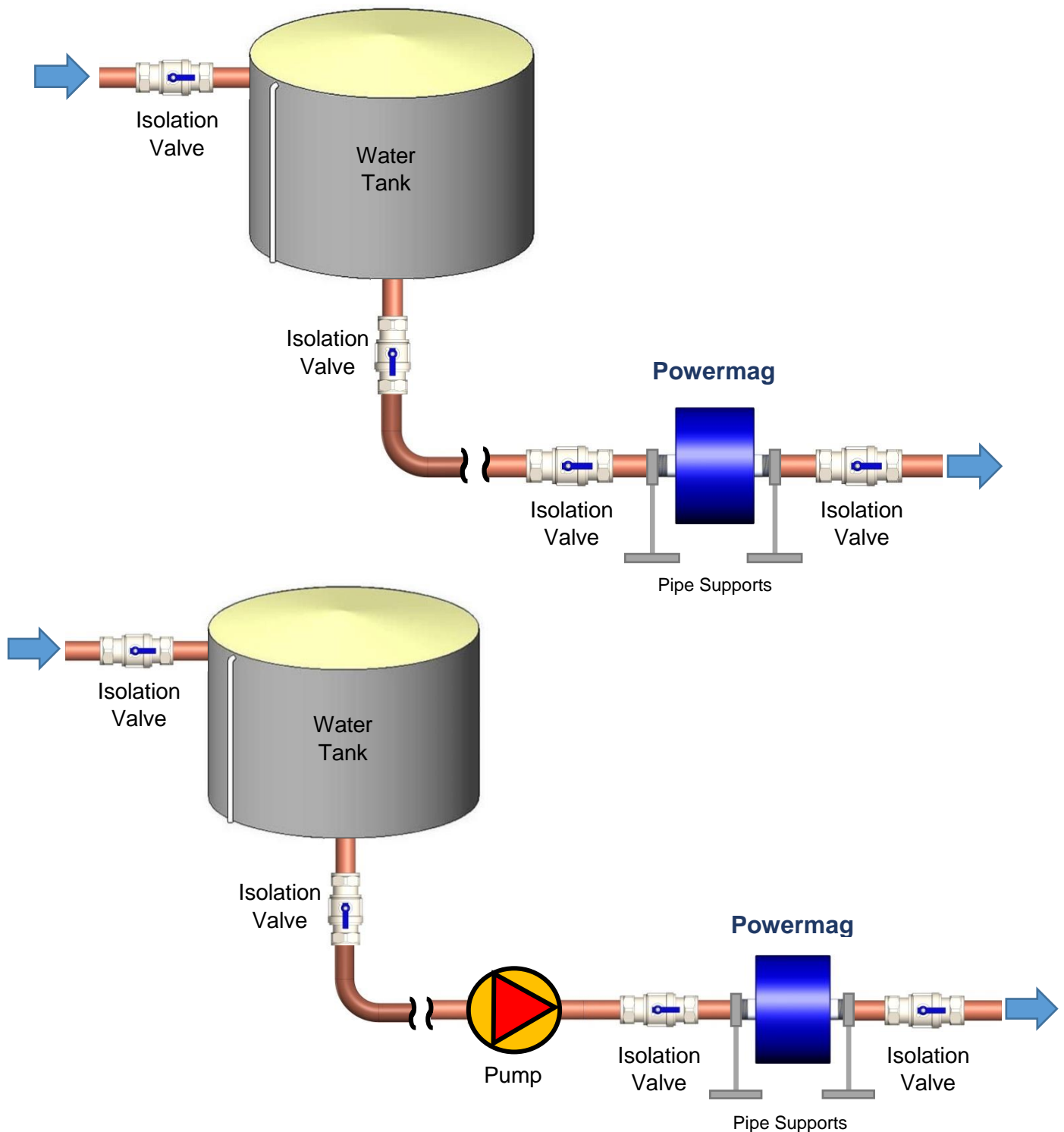

Key to LCD Display

- Running Temperature: Temperature reading from the thermistor on the outlet pipework
- Coil Current: Operating current of electromagnet
- Hours Run: Total hours of coil operation since installation
- Set Temperature: Maximum temperature setting for thermistor circuit
- Coil Status: Current status of the coil
 - Coil Active when operational
 - Coil Inactive when thermistor set temperature is achieved
- Activity LED Display: Visual display of coil activity
 - LED will run left to right when active
 - LED will halt when inactive
 - LED will illuminate fully when a fault is present

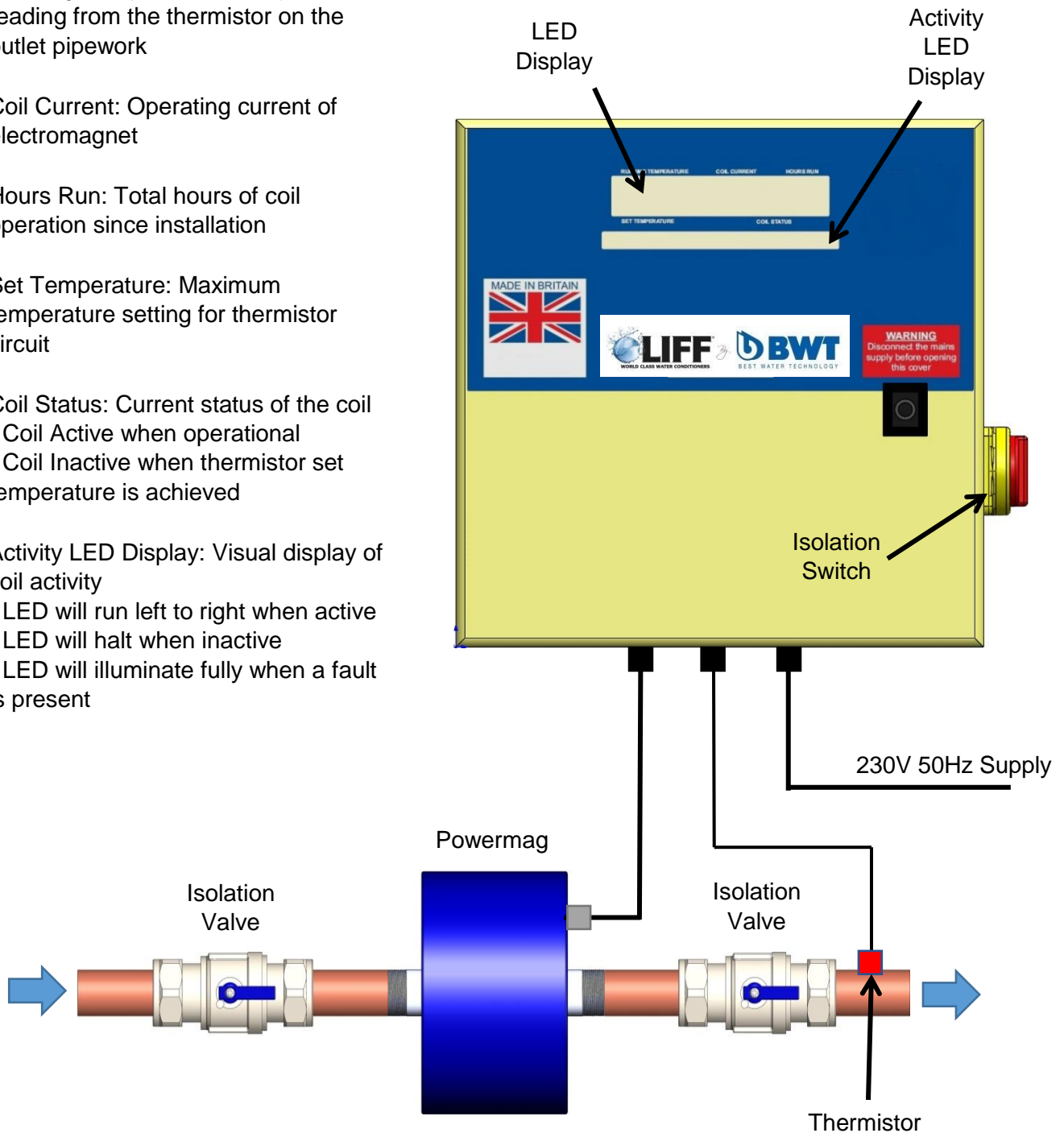

Powermag coil flying lead length supplied: 4.5m (approx.)

Thermistor lead length supplied: 2.5m (approx.)

Attach to the pipe surface downstream of the device using cable tie or similar

Use for cold water only

Thermistor is a safety and efficiency device for cold water systems and will render the coil inactive when water stops flowing by detecting an increase in the standing water temperature in the pipework

3. Electrical Notes

Identifying the main components

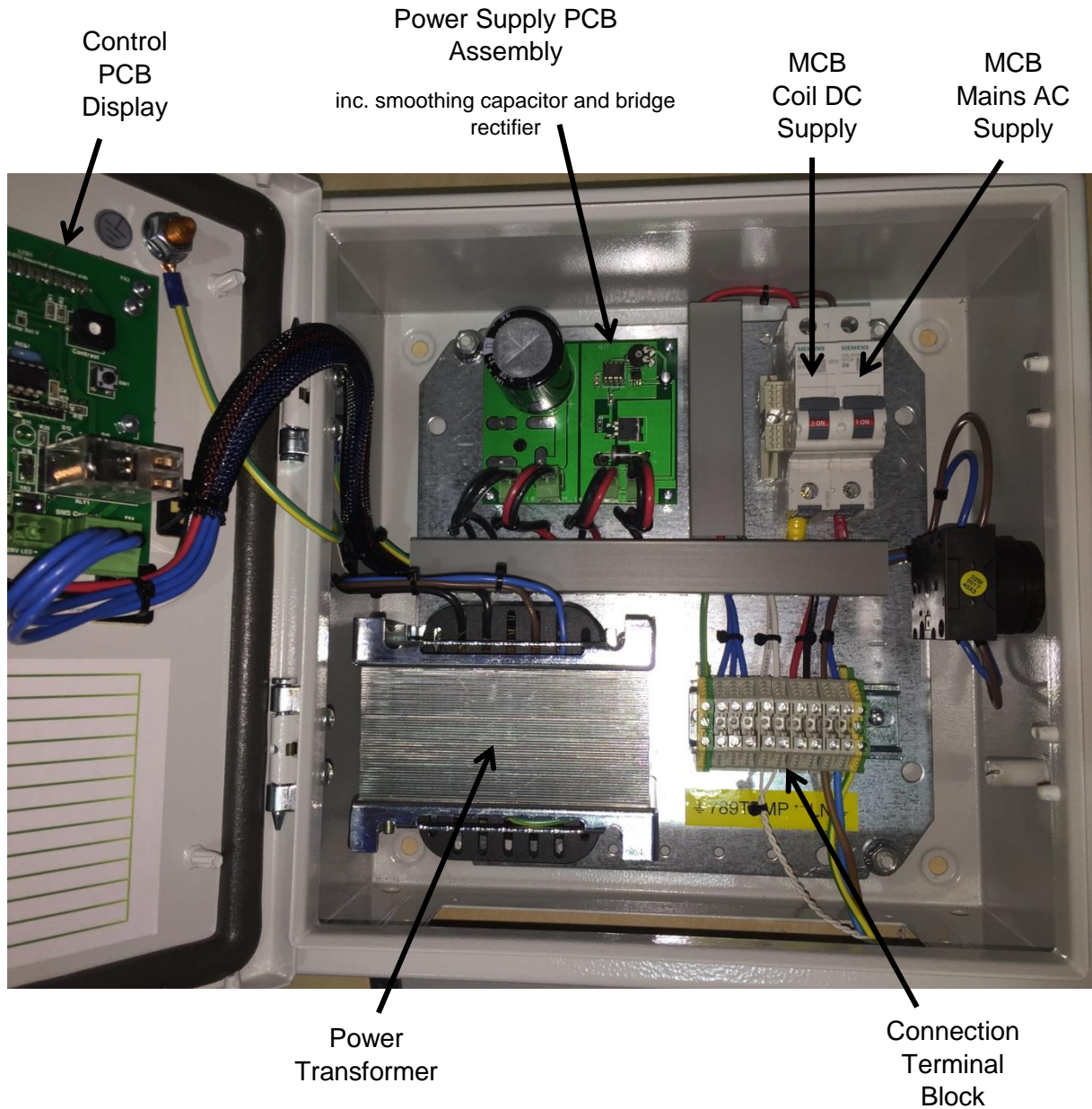

Connection Terminals

- Connect terminals marked L (Live), N (Neutral) and E (Earth) on the right of the terminal box to the fused switched spur for the mains power supply (using the flying lead supplied with the panel or similar)
- Connect flying lead from Powermag coil assembly to the terminals marked:
 + (use brown cable)
 - (use blue cable)
 E (use green / yellow cable) – NOTE: a spare Earth terminal is available on the left of the terminal block
- Connect thermistor cable to 2 central terminals marked TEMP (or Thermistor). The thermistor circuit is a loop so the terminals can be connected either way round
- Terminals 7,8 and 9 are for BMS and fault monitoring systems only
 The diagram below shows the monitoring relay in the power OFF state. When power is ON the terminals 7 and 8 will close circuit

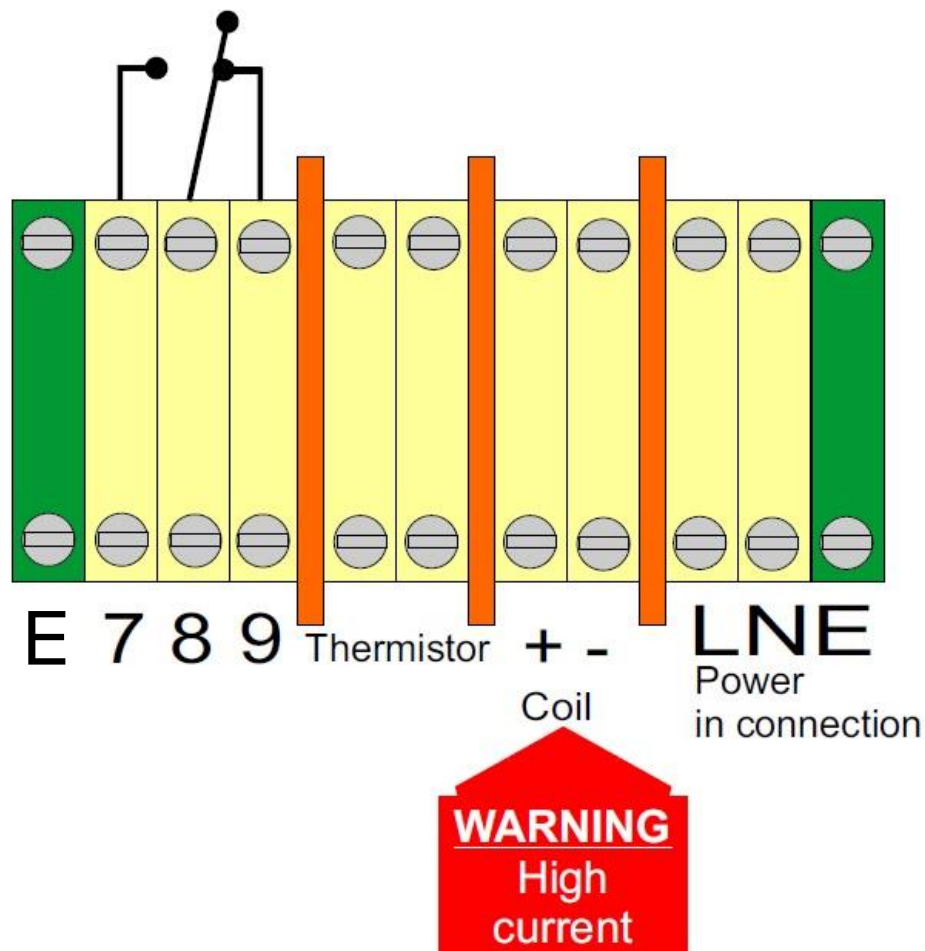

4. Troubleshooting Guide

The following fault table is provided as a guide to resolving operational issues with the Powermag system. Any fault diagnosis must be conducted by a suitably qualified electrical engineer.

Problem	Possible Cause	Recommended Solution
Coil remains inactive	Supply water flow has stopped Water temperature is above the set point of the thermistor	Check water supply flow Do not use thermistor for hot water Adjust thermistor to suit the application using dial on rear of Control PCB Display
Mains MCB tripping	Fault on transformer	Test and replace transformer
Coil DC supply MCB tripping	Fault on coil	Test and replace coil
Panel temperature high	Loose connections on power circuit	Check and secure loose connections
Fault monitoring contacts remain closed	Loss of power to panel	Check power supply and MCB status

5. Spare Parts List

Description	Part Number
Transformer 13.5V (PM100 only)	PMT13.5
Transformer 16V	PM16
Isolation Switch	PMMI30
6A MCB (Mains Supply MCB)	PMCB6
10A MCB (PM100 only)	PMCB10
16A MCB (Coil Supply MCB)	PMCB16
Control PCB Display	PMDISPLAY
Thermistor with lead	PMTHL

For spare parts please contact BWT on 01494 838100 or email commercialuk@bwt-uk.co.uk

6. Specifications

Mechanical Specification

Specification / Model	PM100S	PM150S	PM200S	PM250S	PM300S	PM400S
Pipe Size (BSP male)	1"	1.5"	2"	2.5"	3"	4"
Coil diameter (mm)	324	324	324	324	324	324
Coil width (mm)	140	175	225	225	225	225
Overall length (mm)	180	240	330	330	330	330
Coil weight (kg)	9	20	20	23	24	27
Max flow rate (l/sec)	1.5	3.0	6.0	8.0	12.0	30
Frictional loss (bar)	<0.2	<0.2	<0.2	<0.2	<0.2	<0.2
Max water temperature (°C)	25	25	25	25	25	25
Max pressure (bar)	16	16	16	16	16	16

Electrical Specification

Specification / Model	PM100S	PM150S	PM200S	PM250S	PM300S	PM400S
Transformer Voltage (V)	13.5	16	16	16	16	16
Mains MCB (A)	2	6	6	6	6	6
Coil Supply MCB (A)	10	16	16	16	16	16
AC Power Supply	230V/50Hz	230V/50Hz	230V/50Hz	230V/50Hz	230V/50Hz	230V/50Hz
Power Consumption (kW)	0.2	0.2	0.2	0.2	0.2	0.2

NOTE: MCB ratings are maximum safety ratings. Actual current drawn in operation is significantly lower

7. Warranty Information

The Powermag has been designed to give many years of satisfactory service and is guaranteed against faulty materials and workmanship for a period of 12 months from the date of installation, or 18 months from the date of purchase (depending on which period expires first). Under the provision of this warranty agreement the liability is limited to the repair or replacement cost of the device only and is subject to the terms below

Terms and Conditions of the Warranty:

This warranty provides benefits which are additional to, and do not affect, your legal rights. BWT UK will replace or exchange any necessary parts in order to repair free of charge any Powermag supplied by BWT UK (or its agents) within the United Kingdom (UK Mainland only) where it is shown to the satisfaction of BWT UK to be defective due to faulty workmanship or materials within the warranty period (12 months from installation or 18 months from purchase based on whichever period expires earliest)

What services and associated costs are not included?

Repairs due to breakdown caused by, but not limited to:

- *Use of the equipment for purposes for which it was not designed or intended*
- *Incorrect installation e.g. failure to follow instructions or advice given by BWT UK or its representatives, and failure to follow industry guidelines or standard practice*
- *Any defect caused by malicious or wilful action, negligence, misuse or third party interference*
- *Any defect or damage occasioned by fire, lightning, explosion, flood, storm, frost, impact or other extraneous cause or environmental condition*
- *Consequential loss arising as a result of a defect occurring in the equipment or installation*
- *Any defect or damage arising as a result of failure of the electricity utility supply*

Repair costs for, but not limited to:

- *Consumer replaceable items*
- *Associated items and accessories to the equipment, including pipework, fittings and electrical connections*
- *The expense of a service call when the service engineer finds no fault*

BWT UK Limited
BWT House,
The Gateway Centre,
Coronation Road,
High Wycombe,
Buckinghamshire.
HP12 3SU

Tel: 01494 838100
Fax: 01494 838101
Email: enquiries@bwt-uk.co.uk

www.bwt-uk.co.uk

BWT UK Ltd (2017) endeavour to ensure that the information in this document is correct as stated, but does not accept liability for any error or omission. The development of BWT products is continuous and published information may be out of date. Please check with BWT UK for final specifications.