

Art.Nr.
5903804901
AusgabeNr.
5903804850
Rev.Nr.
01/06/2015

























scheppach



DS920





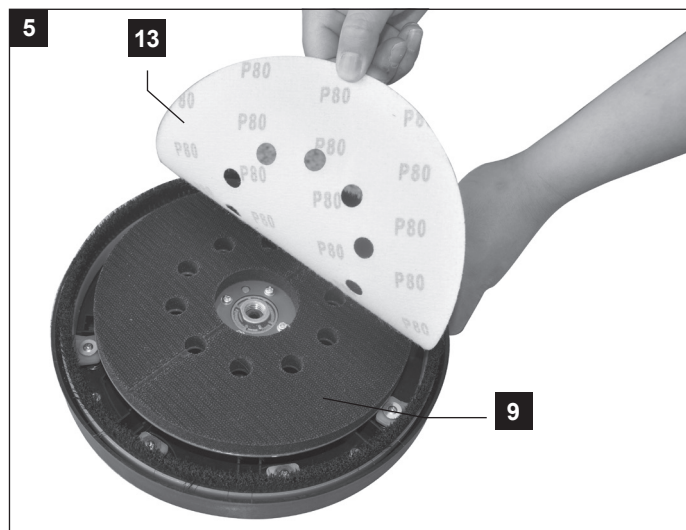
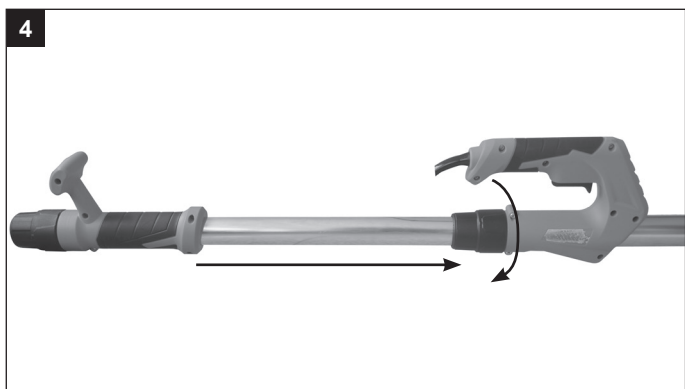
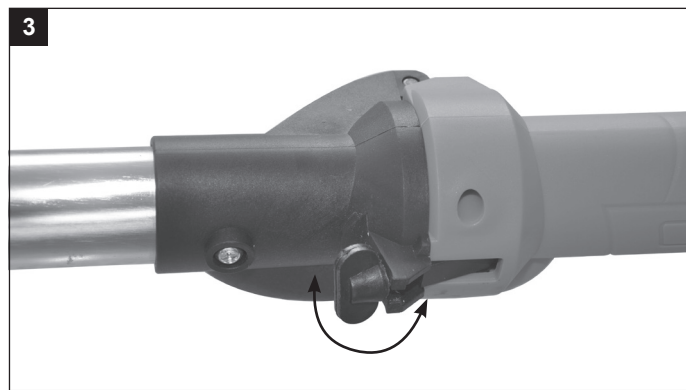
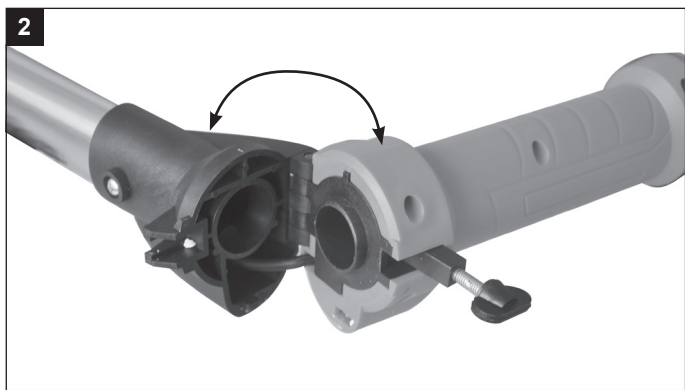
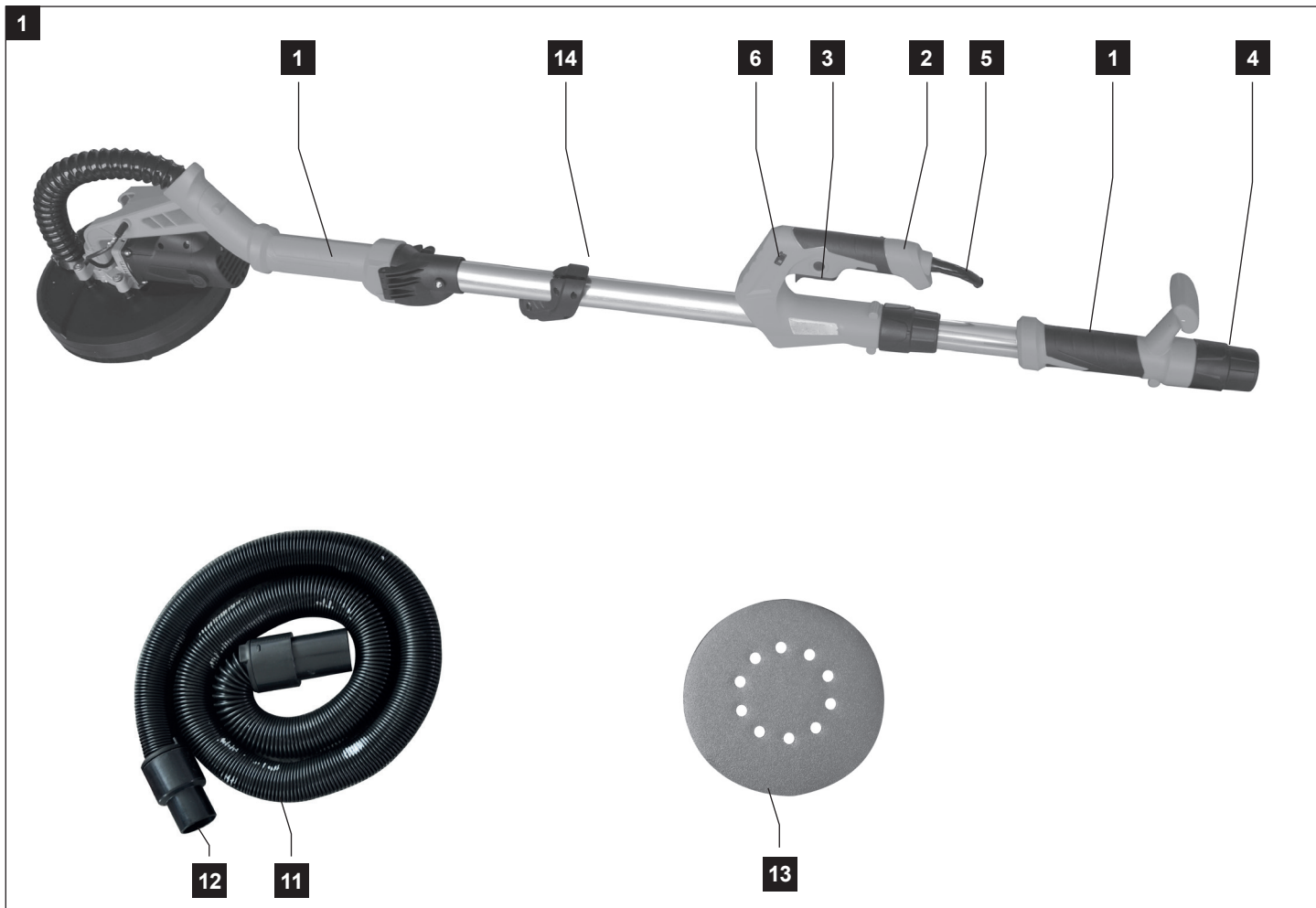

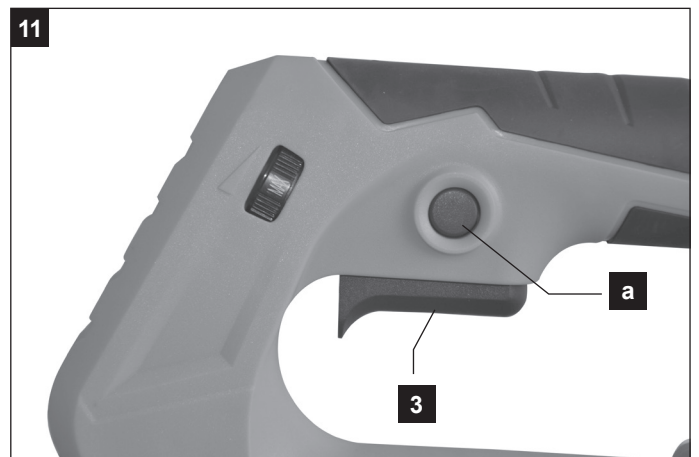
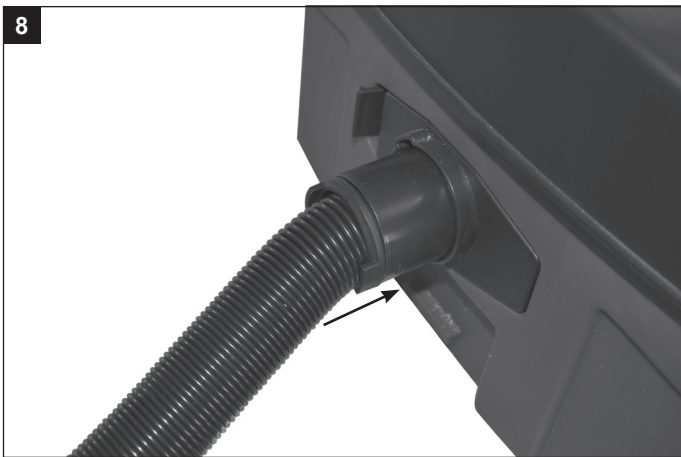
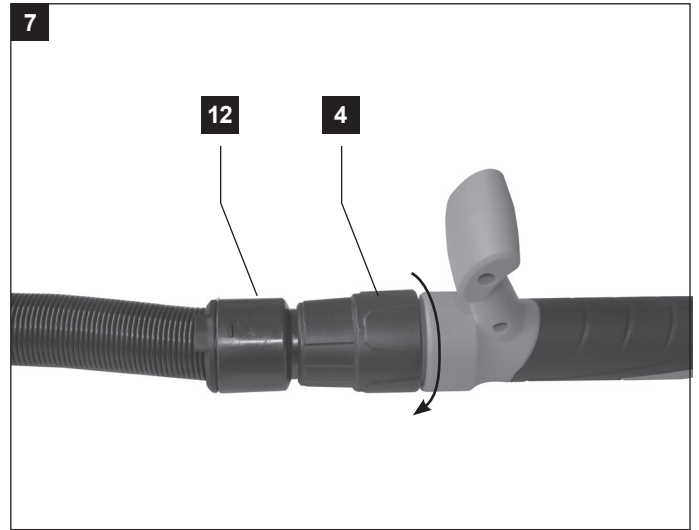
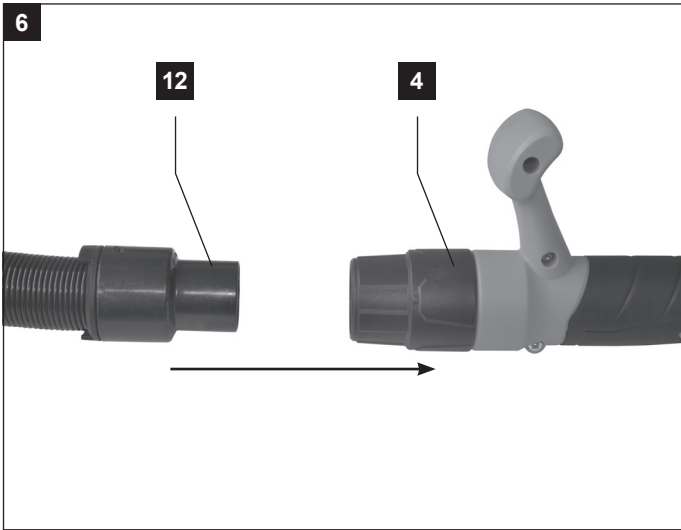





DE	Trockenbauschleifer Originalbetriebsanleitung	6
GB	Drywall Sander Translation of Original Operating Manual	14
FR	Ponceuse de plafond Traduction de la notice originale	21
NL	Langhals-schuurmachine Vertaling van originele gebruiksaanwijzing	28

<p>DE</p> 	<p>Nur für EU-Länder. Werfen Sie Elektrowerkzeuge nicht in den Hausmüll! Gemäß europäischer Richtlinie 2012/19/EU über Elektro- und Elektronik-Altgeräte und Umsetzung in nationales Recht müssen verbrauchte Elektrowerkzeuge getrennt gesammelt und einer umweltgerechten Wiederverwertung zugeführt werden.</p>
<p>GB</p> 	<p>Only for EU countries. Do not dispose of electric tools together with household waste material! In observance of European directive 2012/19/EU on wasted electrical and electronic equipment and its implementation in accordance with national law, electric tools that have reached the end of their life must be collected separately and returned to an environmentally compatible recycling facility.</p>
<p>FR</p> 	<p>Pour les pays européens uniquement Ne pas jeter les appareils électriques dans les ordures ménagères! Conformément à la directive européenne 2012/19/EU relative aux déchets d'équipements électriques ou électroniques (DEEE), et à sa transposition dans la législation nationale, les appareils électriques doivent être collectés à part et être soumis à un recyclage respectueux de l'environnement.</p>
<p>IT</p> 	<p>Solo per Paesi EU. Non gettare le apparecchiature elettriche tra i rifiuti domestici! Secondo la Direttiva Europea 2012/19/EU sui rifiuti di apparecchiature elettriche ed elettroniche e la sua attuazione in conformità alle norme nazionali, le apparecchiature elettriche esauste devono essere raccolte separatamente, al fine di essere reimpiegate in modo eco-compatibile.</p>
<p>NL</p> 	<p>Alleen voor EU-landen. Geef elektrisch gereedschap niet met het huisvuil mee! Volgens de Europese richtlijn 2012/19/EU inzake oude elektrische en elektronische apparaten en de toepassing daarvan binnen de nationale wetgeving, dient gebruikt elektrisch gereedschap gescheiden te worden ingezameld en te worden afgevoerd naar een recycle bedrijf dat voldoet aan de geldende milieu-eisen.</p>
<p>ES</p> 	<p>Sólo para países de la UE ¡No deseches los aparatos eléctricos junto con los residuos domésticos! De conformidad con la Directiva Europea 2012/19/EU sobre residuos de aparatos eléctricos y electrónicos y su aplicación de acuerdo con la legislación nacional, las herramientas eléctricas cuya vida útil haya llegado a su fin se deberán recoger por separado y trasladar a una planta de reciclaje que cumpla con las exigencias ecológicas.</p>
<p>PT</p> 	<p>Apenas para países da UE. Não deite ferramentas eléctricas no lixo doméstico! De acordo com a directiva europeia 2012/19/EU sobre ferramentas eléctricas e electrónicas usadas e a transposição para as leis nacionais, as ferramentas eléctricas usadas devem ser recolhidas em separado e encaminhadas a uma instalação de reciclagem dos materiais ecológica.</p>
<p>SE</p> 	<p>Gäller endast EU-länder. Elektriska verktyg får inte kastas i hushållssoporna! Enligt direktivet 2012/19/EU som avser äldre elektrisk och elektronisk utrustning och dess tillämpning enligt nationell lagstiftning ska uttjänta elektriska verktyg sorteras separat och lämnas till miljövänlig återvinning.</p>
<p>FI</p> 	<p>Koskee vain EU-maita. Älä hävitätä sähkötyökalua tavallisen kotitalousjätteen mukana! Vanhoja sähkö- ja elektroniikkalaitteita koskevan EU-direktiivin 2012/19/EU ja sen maakohtaisten sovellusten mukaisesti käytetyt sähkötyökalut on toimitettava ongelmajätteen keräyspisteeseen ja ohjattava ympäristöstävälliseen kierrätykseen.</p>
<p>NO</p> 	<p>Kun for EU-land. Kast aldri elektroverktøy i husholdningsavfallet! I henhold til EU-direktiv 2012/19/EU om kasserte elektriske og elektroniske produkter og direktivets iverksetning i nasjonal rett, må elektroverktøy som ikke lenger skal brukes, samles separat og returneres til et miljøvennlig gjenvinningsanlegg.</p>
<p>DK</p> 	<p>Kun for EU-lande. Elværktøj må ikke bortskaffes som almindeligt affald! I henhold til det europæiske direktiv 2012/19/EU om bortskaffelse af elektriske og elektroniske produkter og gældende national lovgivning skal brugt elværktøj indsamles separat og bortskaffes på en måde, der skåner miljøet mest muligt.</p>
<p>SK</p> 	<p>Kun for EU-lande. Elværktøj må ikke bortskaffes som almindeligt affald! I henhold til det europæiske direktiv 2012/19/EU om bortskaffelse af elektriske og elektroniske produkter og gældende national lovgivning skal brugt elværktøj indsamles separat og bortskaffes på en måde, der skåner miljøet mest muligt.</p>
<p>SI</p> 	<p>Samo za države EU. Električne orodja ne odstranjuje s hisnimi odpadki! V skladu z Evropsko direktivo 2012/19/EU o odpani električni in elektronski opremi in z njenim izvajanjem v nacionalni zakonodaji je treba električna orodja ob koncu njihove življenjske dobe ločeno zbirati in jih predati v postopek okulju prijaznega recikliranja.</p>
<p>HU</p> 	<p>Csak EU-országok számára. Az elektromos kéziszerszámokat ne dobja a háztartási szemétté! A használt villamos és elektronikai készülékekről szóló 2012/19/EU irányelv és annak a nemzeti jogba való átültetése szerint az elhasznált elektromos kéziszerszámokat külön kell gyűjteni, és környezetbarát módon újra kell hasznosítani.</p>
<p>HR</p> 	<p>Samo za EU-države. Električne alate ne odlažite u kućne otpatke! Prema Europskoj direktivi 2012/19/EU o starim električnim i elektroničkim strojevima i usklađivanju s hrvatskim pravom istrošeni električni alati moraju se sakupljati odvojeno i odvesti u pogon za reciklažu.</p>
<p>CZ</p> 	<p>Jen pro státy EU. Elektrické nářadí nevyhazujte do komunálního odpadu! Podle evropské směrnice 2012/19/EU o nakládání s použitými elektrickými a elektronickými zařízeními a odpovídajících ustanovení právních předpisů jednotlivých zemí se použitá elektrická nářadí musí sbírat odděleně od ostatního odpadu a podrobit ekologicky šetrnému recyklování.</p>
<p>PL</p> 	<p>Tylko dla państw UE. Proszę nie wyrzucać elektronarzędzi wraz z odpadami domowymi! Zgodnie z europejską Dyrektywą 2012/19/EU dot. zużytego sprzętu elektrycznego i elektronicznego oraz odpowiednikiem w prawie narodowym zużyte elektronarzędzia muszą być oddzielnie zbierane i wprowadzane do ponownego użytku w sposób nieszkodliwy dla środowiska.</p>
<p>RO</p> 	<p>Numai pentru țările din UE. Nu aruncați echipamentele electrice la fel ca reziduurile menajere! Conform Directivei Europene 2012/19/EU privitoare la echipamente electrice și electronice scoase din uz și în conformitate cu legile naționale, echipamentele electrice care au ajuns la finalul duratei de viață trebuie să fie colectate separat și trebuie să fie preluate unei unități de reciclare.</p>
<p>EE</p> 	<p>Kehtib vaid EL maade suhtes. Ärge kasutage elektritööriistu koos majapidamisjätmetega! Vastavalt EU direktiivile 2012/19/EU elektri- ja elektroonikaseadmete jätmete osas ja kooskõlas igas riigis kehtivate seadustega, kehtib kohustus koguda kasutatud elektritööriistad eraldi kokku ja suunata need keskkonnasõbralikku taasinglusesse.</p>
<p>LV</p> 	<p>Tikai attiecībā uz ES valstīm. Neutilizējiet elektriskas ierīces kopā ar sadzīves atkritumiem! Pagal Eiropas Direktīvu 2012/19/EU par elektrisko un elektronisko iekārtu atkritumiem un tās ieviešanu saskaņā ar nacionālo likumdošanu, elektriskas ierīces, kas nokalpojušas savu mūžu, ir jāsavāc atsevišķi un jāatgriež videi draudzīgās pārstrādes vietās.</p>
<p>LT</p> 	<p>Tik ES šalims. Nemesti elektros prietaisų kartu su kitomis namų ūkio atliekomis! Pagal Europos Sąjungos direktyvą 2012/19/EU dėl elektros ir elektroninės įrangos atliekų ir jos vykdymo pagal nacionalinius įstatymus elektros įrankius, kurių tinkamumo naudoti laikas pasibaigė, reikia surinkti atskirai ir perduoti aplinkai nekenksmingo pakartotinio perdirbimo įmonei.</p>
<p>IS</p> 	<p>Aðeins fyrir lönd ESB: Ekki henda rafmagnstækjum með heimilisúrgangni! Í fylgni við evrópsku tilskipunina 2012/19/EU um fargaðan rafbúnað og rafmagnan búnað og framkvæmd þess í samræmi við innlend lög, verða rafmagnstæki sem úr sér gengin.</p>





Explanation of symbols used on the device

		<p>Warning! Failure to comply with possible danger to life, risk of injury or damage to the tool!</p>
		<p>Caution - Read the operating instructions to reduce the risk of injury</p>
		<p>Wear safety goggles!</p>
		<p>Wear ear-muffs!</p>
		<p>Wear a breathing mask!</p>
		<p>Protection class II</p>

Introduction

MANUFACTURER

scheppach

Fabrikation von Holzbearbeitungsmaschinen GmbH
Günzburger Straße 69
D-89335 Ichenhausen

DEAR CUSTOMER,

We wish you much joy and success in working with your new device.

NOTE:

According to the applicable product liability laws, the manufacturer of the device does not assume liability for damages to the product or damages caused by the product that occurs due to:

- Improper handling,
- Non-compliance of the operating instructions,
- Repairs by third parties, not by authorized service technicians,
- Installation and replacement of non-original spare parts,
- Application other than specified,
- A breakdown of the electrical system that occurs due to the non-compliance of the electric regulations and VDE regulations 0100, DIN 57113 / VDE0113.

We recommend:

Read through the complete text in the operating instructions before installing and commissioning the device. The operating instructions are intended to help the user to become familiar with the machine and take advantage of its application possibilities in accordance with the recommendations. The operating instructions contain important information on how to operate the machine safely, professionally and economically, how to avoid danger, costly repairs, reduce downtimes and how to increase reliability and service life of the machine.

In addition to the safety regulations in the operating instructions, you have to meet the applicable regulations that apply for the operation of the machine in your country. Keep the operating instructions package with the machine at all times and store it in a plastic cover to protect it from dirt and moisture. Read the instruction manual each time before operating the machine and carefully follow its information. The machine can only be operated by persons who were instructed concerning the operation of the machine and who are informed about the associated dangers. The minimum age requirement must be complied with.

Intended use

The intended use of this power tool is the sanding of large areas of drywalls as a preparation before painting or wallpapering using suitable abrasive sheets.

This power tool is neither suited for the preparation of small areas, corners and edges, nor for the removal of wallpaper and the grinding of ceilings and wet grinding.

Do not use the power tool for cutting or roughing or polishing. Do not use it together with wire brushes. Do not treat asbestos containing materials with this power tool.

This power tool is solely intended for private use. Do not use the power tool for any other purpose than for the intended one. Any other use beyond the intended use is improper.

For any resulting damage or injury, the user/Operator is held liable, not the manufacturer.

Technical Data

Nominal voltage:	230 V
Nominal frequency:	50 Hz
Power consumption:	710 W
Nominal speed (oscillation rate) n:	700 - 1700 1/min
Spindle size:	M14
Grinding disc diameter:	210 mm
Abrasive paper diameter:	214 mm
Protection class:	II
Weight.:	approx 4.5 kg
Sound level	
Sound pressure level L_{PA}:	78 dB(A)
Sound power level L_{WA}:	89 dB(A)
Uncertainty K	3 dB(A)
Hand-arm vibration	
When grinding with abrasive sheets a_h	2.28 m/s²
Uncertainty K:	1.5 m/s²

The specified hand-arm vibration value is based on grinding with an abrasive sheet. Different applications may result in different values.

The noise and vibration values were determined according to EN 60745-1 and EN 60745-2-3.

The specified vibration value was measured on the basis of a standard test method and can be used to compare any kind of power tools.

The specified vibration value can also be used for the initial evaluation of exposure.

Warning! Depending on how you use the power tool, the actual vibration values may deviate from the specified values!

Take measures to protect yourself against vibrations!

Make sure to take into account the entire work process, i.e. also times when the power tool is operated without load or switched off! Appropriate measures include the regular maintenance and care of the power tool and its attachments, keeping your hands warm, regular breaks and planned work processes!

General safety notes for power tools

Warning! Read all safety notes and instructions! Non-compliance with safety notes and instructions may result in electric shock, fire and/or severe injury!

Store all safety notes and instructions for the future.

The term „power tool“ used in the safety notes refers to power tools connected to the mains (with a power cable) or operated with a battery (without a power cable).

Workplace safety

a) Keep your workplace clean and well illuminated.

Disorderliness and poorly illuminated workplaces may lead to accidents.

b) Do not operate the power tool in explosive atmospheres with inflammable liquids, gases or dust. Power tools generate sparks which may ignite dust or vapours.

c) Keep children and other persons away from the power tool during operation. You may lose control of the tool if you are distracted.

Electric safety

a) The plug of the power tool must fit into the socket. Do not modify the plug in any way. Do not use adapter plugs together with grounded power tools. Unmodified plugs and matching sockets reduce the risk of electric shock.

b) Avoid body contact with grounded surfaces such as pipes, radiators, ovens and refrigerators. There is an increased risk of electric shock if your body is grounded.

c) Keep power tools away from rain or humidity. Water permeation into the power tool will increase the risk of electric shock.

d) Use the cable solely for its intended purpose. Do not use the cable to carry or hang up the power tool or to pull out the plug from the socket. Keep the cable away from heat, oil, sharp edges or moving machine parts. Damaged or twisted cables increase the risk of electric shock.

e) When working outdoors with power tools, only use extension cords which are suited for outdoor areas. Using extension cords suited for outdoor applications reduces the risk of electric shock.

f) If the operation of power tools in a humid environment cannot be avoided, you must use a residual current circuit breaker. The use of a residual current circuit breaker will reduce the risk of electric shock.

Personal safety

a) Pay attention to what you are doing and use power tools sensibly. Do not use power tools when you are tired or under the influence of drugs, alcohol or medication. A single moment of inattention while using power tools may cause severe injury.

b) Wear personal protective equipment and safety goggles. Wearing personal protective equipment such as a dust mask, non-skid safety boots, a protective helmet or hearing protection according to the type and application of the power tool reduces the risk of injury.

c) Avoid starting the power tool unintentionally. Make sure that the power tool is switched off before you connect it to the mains and/or insert a battery, pick it up or carry it. If you have your finger on the switch when you carry the power tool, or if the machine is switched on when you connect it to the mains, this may result in accidents.

d) Remove adjustment tools or wrenches before

switching on the power tool. Tools or wrenches in rotating machine parts may cause injury.

e) Avoid abnormal body positions. Stand securely and keep your balance at all times. By doing so, you can control the power tool more easily in unexpected Situations.

f) Wear suitable clothing. Do not wear loose clothing or jewellery. Keep your hair, clothing and gloves away from moving parts. Loose clothing, jewellery or long hair may be trapped in moving parts.

g) If dust extraction tools or collection bins can optionally be attached, you must make sure that they are connected and correctly used. Using dust extraction tools may reduce risks caused by dust.

Use and treatment of the power tool

a) Do not overload the tool. Use the appropriate power tool for your type of work. With appropriate power tools, you can work better and more safely within the given power range.

b) Do not use power tools with defective switches. Power tools which cannot be switched on or off are dangerous and must be repaired.

c) Pull out the plug from the socket and/or remove the battery before you make settings to the tool, replace accessory parts or put aside the power tool. These precautionary measures will prevent the power tool from starting unintentionally.

d) Keep power tools which are not in use away from children. Only persons who are familiar with the power tool and who have read the operating instructions may use the power tool. Power tools are dangerous if used by inexperienced persons.

e) Maintain power tools with care. Check moving parts for proper function and smooth running, and check whether there are parts which are broken or damaged to the extent that the functionality of the power tool is impaired. Have damaged parts repaired before using the power tool. Many accidents are caused by poorly-maintained power tools.

f) Keep cutting tools sharp and clean. Carefully maintained cutting tools with sharp edges are less likely to jam and can be guided more easily.

g) Use power tools, accessory parts, insertion tools, etc. in compliance with these instructions. Take into account the working conditions and the activity which is to be carried out. Using power tools for applications other than those intended may cause dangerous Situations.

Service

a) Have your power tool repaired by qualified specialists only, and always use original spare parts for repair. This is to maintain the safety of the power tool.

Safety notes for all applications- General safety notes for grinding, sanding, working with wire brushes, polishing and cutting by grinding

a) This power tool must be used as a sandpaper grinder. Observe all safety notes, instructions, illustrations and data which are provided together with the tool. Nonobservance of the following instructions may result in electric shock, fire and/or severe injury.

b) This power tool is not suited for grinding, Operations with wire brushes, polishing and cutting by grinding. Using the power tool for applications other than the intended ones may result in risks and injury.

c) Only use accessory parts especially provided for this tool and recommended by the manufacturer.

The mere fact that you can mount accessory parts to your power tool does not ensure safe use.

- d) **The permissible speed of the insertion tool must be at least as high as the maximum speed specified on the power tool.** Accessories with a higher speed may break and fly off.
- e) **The outer diameter and the thickness of the insertion tool must comply with the dimensions specified on your power tool.** It is not possible to shield or control insertion tools with different dimensions.
- f) **Grinding disks, flanges, grinding plates or other accessory parts must exactly mate the grinding spindle of your power tool.** Insertion tools which do not exactly mate the grinding spindle of your power tool will perform irregular rotations, cause high vibrations and thus the loss of control.
- g) **Do not use damaged insertion tools. Prior to each application, you must check insertion tools such as grinding disks for chippings and cracks, grinding plates for cracks, wear or major abrasion, wire brushes for loose or broken wires. If the power tool or insertion tool falls down, you must check it for damages, or use an undamaged insertion tool. After you have checked and inserted the insertion tool, both you and persons in the vicinity must stay out of the level of the rotating insertion tool, and the tool must be operated at maximum speed for one minute.** Most of the damaged insertion tools will break within this test period.
- h) **Wear personal protective equipment. Depending on the application of the power tool, you must wear a full face shield, eye protection or goggles. If appropriate, you must wear a dust mask, hearing protection, protective gloves or a special apron which protects you against small grinding chips and material particles.** Protect your eyes against foreign objects which fly off during different operations. The purpose of dust masks and breathing equipment is to filter the dust generated during the operation. Long-term exposure to high noise pollution may cause hearing loss.
- i) **Make sure that other persons stay a safe distance away from your working area.** Persons accessing your working area must wear personal protective equipment. Fragments of the work piece or broken insertion tools may fly off and cause injury even outside the direct working area.
- j) **Always hold the tool by its insulated handles when the insertion tool may come into contact with hidden power lines or with the power cord of the power tool.** Contact with live lines may energise metal tool parts and cause electric shock.
- k) **Keep the power cord away from rotating insertion tools.** If you lose control of the power tool, the power cord may be cut or trapped, and your hand or arm may get into the path of the rotating insertion tool.
- l) **Never put aside the power tool before the complete halt of the insertion tool.** Rotating insertion tools may get in contact with the place of deposit thus causing the loss of control of the tool.
- m) **Switch off the power tool while you carry it around.** Your clothes may be trapped when unintentionally getting in contact with the rotating insertion tool and the insertion tool may penetrate your body.
- n) **The ventilation slots of your power tool must be cleaned on a regular basis.** The motor fan sucks in dust, and the accumulation of metal dust may cause electrical risks.
- o) **Do not use the power tool in the vicinity of inflammable materials.** Sparks may ignite these ma-

terials.

- p) **Do not use insertion tools which require liquid coolants.** Using water or other liquid coolants may cause electric shock.

Further safety notes for all applications - kickback and corresponding safety notes

A kickback is the sudden reaction caused by rotating insertion tools such as a grinding disk, grinding plate, wire brush, etc. which has got caught or which blocks. Getting caught or blocking results in the immediate stop of the rotating insertion tool. This accelerates the uncontrolled power tool against the rotary direction of the insertion tool.

If for example a grinding disk gets caught or blocks in the work piece, the edge of the grinding disk which penetrates the work piece may get caught, the grinding disk will make a sudden movement or cause a kickback. As a result, the grinding disk moves towards the operator or away from the operator, depending on the rotary direction of the disk when it blocks. This may also cause the fracture of grinding disks.

Kickbacks are the result of the improper or incorrect use of power tools. Kickbacks can be avoided when observing the following precautionary measures.

- a) **Hold the power tool firmly in your hands and bring your body and arms in a position which allows you to adequately react to kickback forces. Always use the additional handle, if available.** This ensures you the utmost control of kickback forces or reaction torques when starting your power tool. When taking appropriate precautions, the operator is in the position to control kickback and reaction forces.
- b) **Keep your hands away from rotating insertion tools.** The insertion tool may move over your hand in the event of a kickback.
- c) **Keep your body away from the area where the power tool may move in the event of a kickback.** Kickbacks always move the power tool in opposite direction to the movement of the grinding disk at the spot where it blocks.
- d) **Corners, sharp edges, etc. must be processed with special care.** Make sure that the insertion tool does not bounce back from or get trapped on the work piece. The rotating insertion tool tends to jam in corners, at sharp edges or when it bounces back. This may cause the loss of control or a kickback.
- e) **Do not use chain rings or toothed saw blades.** These insertion tools frequently cause kickbacks or the loss of control of your power tool.

Additional safety notes regarding grinding with sandpaper- Special safety notes regarding grinding with sandpaper

- a) **Do not use oversized abrasive sheets; always observe the manufacturer's specifications for abrasive sheet dimensions.** Abrasive sheets protruding the grinding plate may cause injury or result in the blocking or tearing apart of the abrasive sheet or in kickbacks.

Additional safety notes

- a) Connect a vacuum cleaner to the supplied adapter before starting your operations.
- b) Attention! Keep away grinding dust from open fire. Dust may be explosive.
- c) Always wear goggles and a dust mask when grinding, in particular du ring overhead work and when processing critical materials! When grinding certain materials (e .g.lead paint, certain types of wood and metal) harmful or noxious dust may be generated. Touching or breathing in such dust may imply risks for the operator or people in the vicinity.

Notes regarding vibration and noise emissions

Reduce noise emissions and vibrations to a minimum!

1. Only use power tools which are free of defects.
2. Maintain and clean the power tool on a regular basis.
3. Adjust your way of working to the power tool.
4. Do not overload your power tool.
5. Have your power tool inspected, if necessary.
6. Switch off the power tool when it is not in use.

Remaining risks

Even if you use this power tool in compliance with the regulations, there are still remaining risks. The following risks may occur due to the type and design of the power tool:

- a) Damage caused to your health resulting from hand/arm vibrations if the power tool is used over a longer period of time or if it is not properly used and maintained.
- b) Injury and damage to property caused by flying off insertion tools which are unexpectedly expelled from the power tool due to sudden damage, wear or incorrect insertion.
- c) Burns and cuts if the insertion tools are touched directly after use and/or with your bare hands.

Warning! This electric tool generates an electromagnetic field du ring operation which may impair active or passive medical implants under certain circumstances. In order to reduce the risk of severe or lethal injury, we recommend that persons with medical implants consult their doctor and the manufacturer of the medical implant before using the power tool.

Tool description and scope of delivery

Tool description (Fig.1)

The tool description refers to the illustration at the beginning of this instruction manual.

1. Handle surface
2. Main handle
3. On/off switch
4. Adapter with connecting nut
5. Powercord
6. Adjustment wheel for speed pre-selection
7. Ventilation opening
8. Flexible grinding head
9. Grinding plate
10. Brush edge
11. Extraction hose
12. Hoseadapter
13. Abrasive sheet
14. LED-Light

Scope of delivery (Fig.1)

- 1 drywall sander
- 1 extraction hose (1 1)
- 2 hose adaptor (1 2)
- 6 abrasive sheets (1 3) (different grain sizes)

Before start-up

unpacking

1. Open the packaging and carefully takeout the power tool.
2. Remove the packaging material as weil as the packaging I transport lacks (if any).
3. Check the scope of delivery for completeness and check the power tool and the accessory parts for transport damage.

Note: Do not start the power tool if you notice that parts are missing or damaged. Contact the retailer where you purchased this power tool.

4. Store the packaging until the end of the warranty period, if possible. Please dispose ofthe packaging in accordance with environmental regulations and take it to a recycling depot.

WARNING!

Neither power tools nor packaging materials are toys! Children must not play with plastic bags, foils and small parts! Danger of swallowing and suffocation!

Installation

- Fold the front and back parttogether (Fig.2). And then tighten the screw nut. (Fig.3).
- The longest length installation Insert the additional handle to the end of the machine. And then turn the screw nut on the end ofthe machine for tightening. (Fig.4)

Sandpaper

Selection

1. The grain size of the sandpaper is specified on its rear side. The smaller the specified number, the coarser the graining.
2. Use sandpaper with coarse grain for rough grinding, and sandpaper with fine grain for finishing. We recommend sandpapers with aluminium oxide, silicon carbide or other synthetic abrasives.
3. If you can chose between sandpapers with different graining, you should start with coarsegraining sandpaper and complete the grinding process with the finest possible graining. Thus you will get good and smooth grinding results.

How to apply and replace sandpaper

Apply the sandpaper (13) to the grinding plate (9) using the Velcro strip mechanism.

1. Align the sandpaper (13) with the grinding plate (9) and press it on evenly.
2. Pull the sandpaper (13) off the grinding plate (9) and replace it with a new one I another one (Fig.5).

Dust extraction

WARNING! Harmfull noxious gases may be generated when e.g. lead-containing paint is processed. These gases entail a risk for the operator and the persons in the vicinity!

Therefore only use the power tool in combination with a dust extraction unit, and protect yourself and other persons in the working area with additional suitable personal protective equipment!

When working with this power tool, a lot of dust is generated. The dust extraction unit is very useful if you want to keep your workplace clean. It is possible to combine the extraction system or a vacuum cleaner with the extraction hose (11) which is connected to the adapter for dust extraction.

1. Align the nose at the hoseend with the extraction hose adapter (12) (Fig.3), insert the end and secure it

- by turning in a clockwise rotation (Fig.7).
2. Connect the dust extraction adapter with a suitable dust extraction unit such as a vacuum cleaner (Fig.8).

Note: Make sure that the vacuum cleaner is suitable for being used together with a power tool.

Brush edge

The grinding head of this power tool is enclosed by a brush edge (10) which offers the following two advantages:

- a) The brush edge (10) protrudes beyond the grinding plate (9) and touches the surface to be processed first. Thus, the grinding plate is positioned in parallel to the working area before the insertion tool comes in contact with the surface which is to be processed. This is to prevent the formation of sickle-shaped recesses caused by the grinding disk edge.
- b) Furthermore, the brush edge (10) prevents the generation of excessive dust. Dust generated during the grinding process is not transported towards the outside but is removed by the extraction system. Make sure before each operation with this power tool that the brush edge (10) is not damaged. Have it replaced if there is damage or wear.

Connection to the power supply

1. Make sure that the power tool is switched off. Always switch the on/off switch (3) to off position before connecting the power tool to the power supply.
2. Plug the power plug into a correctly installed socket which complies with the requirements specified in the technical data.
3. Your power tool is now ready for operation.

Operation

Oscillation rate

Before you start working with the swing speed to match the appliance. Use a low swing speed for coarse grinding, increase the oscillation rate for fine work.

1. Rotate the adjustment wheel (6) to adjust the oscillation rate. Turn the wheel clockwise to reduce the oscillation rate (Fig.9).
2. Turn the wheel counter-clockwise to increase the oscillation rate (Fig. 10).

Switching on/off

To switch on:

Push the on/ off switch (3)

Continuous operation: (Fig.11)

Secure the on/off switch (3) with the locking button (a)

To switch off:

Press the on/off switch (3) briefly.

Note: The insertion tool moves for a short while after having it switched off. Do not put aside the power tool until the insertion tool has come to a complete halt.

Grinding

1. Attach an appropriate abrasive sheet (13) and select the corresponding speed.
2. Hold the power tool securely at the handle surfaces (1, 2) and switch it on as described.
3. Wait until the insertion tool has reached its full operating speed.
4. Hold the grinding plate (9) as parallel as possible to the wall, and touch the surface to be processed with the brush edge (10) first.
5. Apply some pressure to the grinding head (8) such that the insertion tool touches the surface to be pro-

cessed.

6. Constantly move the power tool over the surface.

Note: If you want to avoid irregular grinding results, do not keep the power tool at one spot for too long.

7. Lift the grinding plate (9) from the surface to be processed before switching off the power tool.
8. Do not put aside the power tool until the insertion tool has come to a complete halt.

After use

1. Switch off the power tool as described, disconnect it from the power supply and let it cool down.
2. Clean and maintain the power tool as described below, and store it carefully.

Cleaning, maintenance and repair

WARNING! Unplug the power tool before starting to work on it (e.g. transport, installation, retrofitting, cleaning and maintenance)!

Cleaning

- a) Keep protective devices, ventilation openings and motor housings free from dust and dirt as far as possible.
- b) Wipe the power tool with a clean cloth or remove dust and dirt with compressed air at low pressure (max. 3 bar).
- c) Clean the power tool immediately after each use.
- d) Do not use any detergents or solvents as they may affect the plastic parts of the power tool. Make sure to avoid any water ingress into the tool.

Replacing the power supply line

If the power supply line of this power tool is damaged, it must be replaced by the manufacturer or the customer service or any equally qualified person in order to avoid risks.

Maintenance

Check the power tool and accessory parts (e.g. insertion tools) for wear and damage before and after each operation. If necessary, replace worn out or damaged parts with new parts and make sure to comply with the operating instructions. Observe any technical requirements.

Grinding plate, brush edge

Have a qualified specialist replace damaged or worn out grinding plates (9) and brush edges (10) with new ones of the same type.

Replacing the power supply line

If the power supply line of this power tool is damaged, it must be replaced by the manufacturer or the customer service or an equally qualified person in order to avoid risks.

WARNING! There are no parts inside the power tool which can be serviced by the operator! Never open the power tool! Take it to a qualified specialist for further maintenance!

Storage and transport

1. Whenever you do not use the power tool, you must keep it in a dry and well ventilated place out of the reach of children, e.g. on a high cabinet or in a closed place.
2. Keep power tool, instruction manual and accessory parts, if any, together in the original packaging, if possible. Thus you have all information and parts available at any time.
3. Always hold the power tool by its handle.
4. To avoid transport damages, you must pack the power tool or use the original packaging.
5. Protect the power tool against vibrations and shock, especially during transport in vehicles.

Troubleshooting

Supposed malfunctions, errors or damages are often caused by events which can be remedied by the operator. Therefore check the power tool on the basis of the following table before you contact a specialist. Many malfunctions may thus be remedied.

Problem	Possible cause	Approach
1. Power tool does not start	Power supply interrupted	Check power supply by connecting another power tool
	Power cord or plug defective	Have an electrician check the tool
	Other electrical defect of the power tool	Have an electrician check the tool
2. Power tool does not operate with full power	Extension cord too long and/or cross-section too small	Use extension cord with permissible length and/or adequate cross-section
	Power supply (e.g. generator) voltage too low	Connect power tool to an appropriate power supply
3. Poor operation results	Power tool worn out	Replace insertion tool
	Grinding plate worn out	Have grinding plate replaced
4. Considerable dust formation	Brush edge worn out	Have brush edge replaced
	Dust extraction not connected / switched on	Connect / switch dust extraction

Konformitätserklärung



DE	erklärt folgende Konformität gemäß EU-Richtlinie und Normen für den Artikel	SK	prehlasuje nasledujúcu zhodu podľa smernice EU a noriem pre výrobok
GB	hereby declares the following conformity under the EU Directive and standards for the following article	EST	kinnitab järgmist vastavust vastavalt ELi direktiivi ja standardite järgmist artiklumbrit
FR	déclare la conformité suivante selon la directive UE et les normes pour l'article	LT	pareiškia, taip atitiktis pagal ES direktyvos ir standartai šį straipsnį
IT	dichiara la seguente conformità secondo le direttive e le normative UE per l'articolo	LV	apliecina šādu saskaņā ar ES direktīvu atbilstības un standarti šādu rakstu
CZ	prohlašuje následující shodu podle smernice EU a norem pro výrobek	NL	verklaart hierbij dat het volgende artikel voldoet aan de daarop betrekking hebbende EG-richtlijnen en normen
HU	az EU-irányelv és a vonatkozó szabványok szerinti következo megfeleloségi nyilatkozatot teszi a termékre	RUS	заявляет о соответствии товара следующим директивам и нормам ЕС
HR	ovime izjavljuje da postoji sukladnost prema EU-smjernica i normama za sljedece artikle	PT	declara o seguinte conformidade com a Directiva da UE e as normas para o seguinte artigo
RO	declară următoarea conformitate corespunzător directivelor și normelor UE pentru articolul	ES	declara la conformidad siguiente según la directiva la UE y las normas para el artículo
TR	Normları gereğince aşağıdaki uygunluk açıkla masını sunar.	DK	erklærer hermed, at følgende produkt er ioverensstemmelse med nedenstående EUDirektiver og standarder:
FIN	vakuuttaa täten, että seuraava tuote täyttää ala esitettyt EU-direktiivit ja standardit	SE	försäkrar härmed följande överensstämmelse enligt EU-direktiv och standarder för följande artikeln
PL	deklaruje, że produkt jest zgodny z następującymi dyrektywami UE i normami	NO	erklærer herved følgende samsvar under EU-direktiv og standarder for følgende artikkel
SLO	izjavlja sledeco skladnost z EU-direktivo in normami za artikel	BG	декларира съответното съответствие съгласно Дирек-тива на ЕС и норми за артикул

Drywall Sander - DS920

<input type="checkbox"/> 2009/105/EC	<input type="checkbox"/> 89/686/EC_96/58/EC
<input type="checkbox"/> 2006/95/EC	<input checked="" type="checkbox"/> 2006/42/EC
<input type="checkbox"/> 2006/28/EC	Annex IV Notified Body:xxx Notified Body No.: xxx Reg. No.: xxx
<input type="checkbox"/> 2005/32/EC	<input type="checkbox"/> 2000/14/EC_2005/88/EC
<input checked="" type="checkbox"/> 2004/108/EC	Annex V
<input type="checkbox"/> 2004/22/EC	Annex VI Noise: measured L _{WA} = xx dB(A); guaranteed L _{WA} = xx dB(A) Notified Body: Notified Body No.:
<input type="checkbox"/> 1999/5/EC	<input type="checkbox"/> 2004/26/EC
<input type="checkbox"/> 97/23/EC	Emission. No:
<input type="checkbox"/> 90/396/EC	
<input checked="" type="checkbox"/> 2011/65/EU	

Standard references: EN 60745-1; EN 60745-2-3; EN 55014-1; EN 55014-2; EN 61000-3-2; EN 61000-3-3

Ichenhausen, den 02.06.2015

Unterschrift / Markus Bindhammer / Technical Director

Art.-No. 5903804901
Subject to change without notice

Documents registrar: Georg Kohler
Günzburger Str. 69, D-89335 Ichenhausen

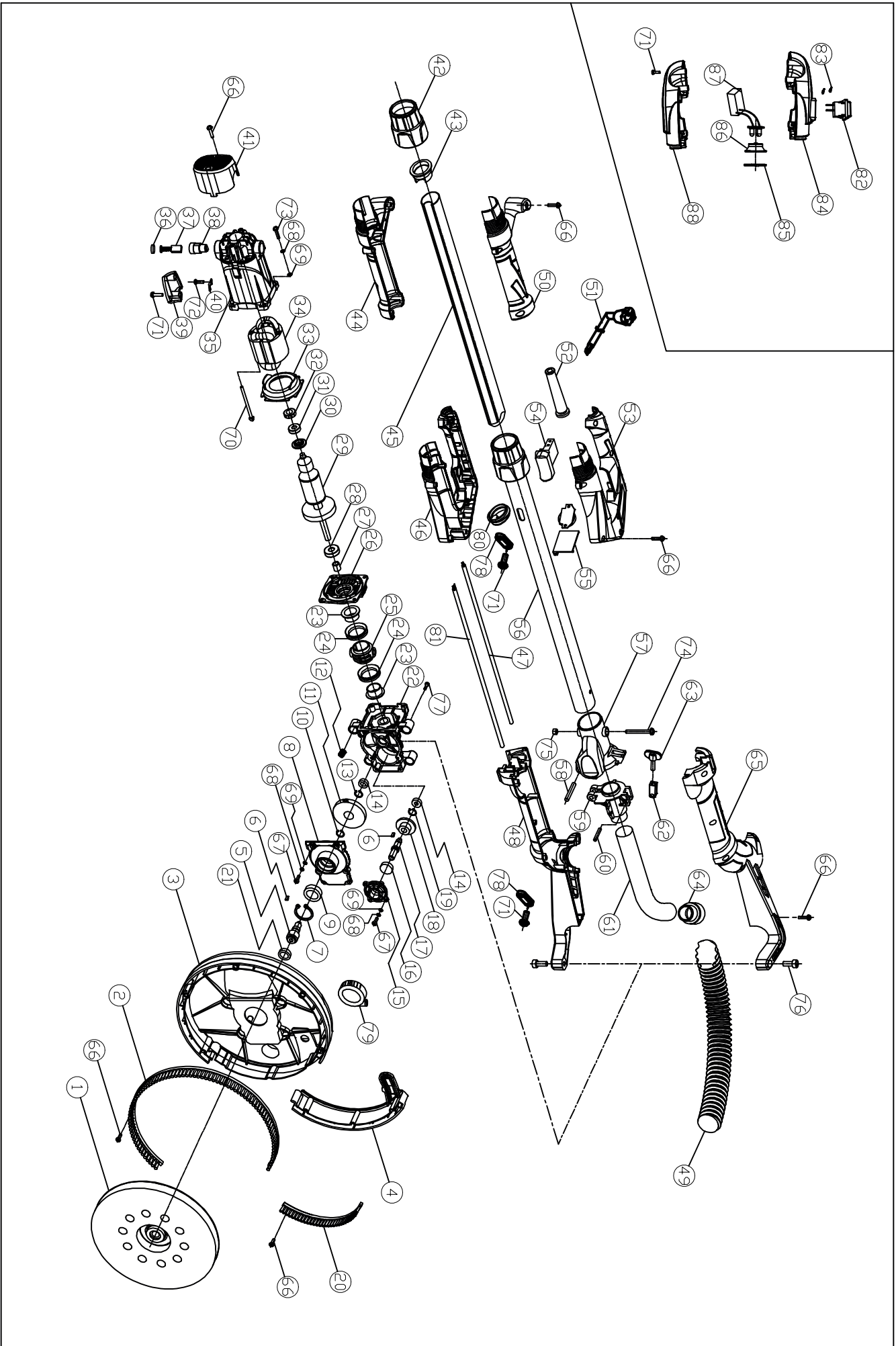

Garantie DE

Offensichtliche Mängel sind innerhalb von 8 Tagen nach Erhalt der Ware anzuzeigen, andernfalls verliert der Käufer sämtliche Ansprüche wegen solcher Mängel. Wir leisten Garantie für unsere Maschinen bei richtiger Behandlung auf die Dauer der gesetzlichen Gewährleistungsfrist ab Übergabe in der Weise, dass wir jedes Maschinenteil, dass innerhalb dieser Zeit nachweisbar in Folge Material- oder Fertigungsfehler unbrauchbar werden sollte, kostenlos ersetzen. Für

Teile, die wir nicht selbst herstellen, leisten wir nur insoweit Gewähr, als uns Gewährleistungsansprüche gegen die Vorlieferanten zustehen. Die Kosten für das Einsetzen der neuen Teile trägt der Käufer. Wandlungs- und Minderungsansprüche und sonstige Schadensersatzansprüche sind ausgeschlossen.

Warranty GB

Apparent defects must be notified within 8 days from the receipt of the goods. Otherwise, the buyer's rights of claim due to such defects are invalidated. We guarantee for our machines in case of proper treatment for the time of the statutory warranty period from delivery in such a way that we replace any machine part free of charge which provably becomes unusable due to faulty material or defects of fabrication within such period of time. With respect to parts not

manufactured by us we only warrant insofar as we are entitled to warranty claims against the upstream suppliers. The costs for the installation of the new parts shall be borne by the buyer. The cancellation of sale or the reduction of purchase price as well as any other claims for damages shall be excluded.

Garantie FR

Les défauts visibles doivent être signalés au plus tard 8 jours après la réception de la marchandise, sans quoi l'acheteur perd tout droit au dédommagement.

Nous garantissons nos machines, dans la mesure où elles sont utilisées de façon conforme, pendant la durée légale de garantie à compter de la réception, sachant que nous remplaçons gratuitement toute pièce de la machine devenue inutilisable du fait d'un défaut de matière ou

d'usinage durant cette période. Toutes les pièces que nous ne fabriquons pas nous-mêmes ne sont garanties que si nous avons la possibilité d'un recours en garantie auprès des fournisseurs respectifs. Les frais de main d'œuvre occasionnés par le remplacement des pièces sont à la charge de l'acquéreur. Tous droits à réhabilitation et toutes prétentions à une remise ainsi que tous autres droits à dommages et intérêts sont exclus

Garanzia IT

Vizi evidenti vanno segnalati entro 8 giorni dalla ricezione della merce, altrimenti decadono tutti i diritti dell'acquirente inerenti a vizi del genere. Appurato un impiego corretto da parte dell'acquirente, garantiamo per le nostre macchine per tutto il periodo legale di garanzia a decorrere dalla consegna in maniera tale che sostituiamo gratuitamente qualsiasi componente che entro tale periodo presenti dei vizi di materiale o di fabbricazione tali da renderlo inutilizzabile. Per

componenti non fabbricati da noi garantiamo solo nella misura nella quale noi stessi possiamo rivendicare diritti a garanzia nei confronti dei nostri fornitori. Le spese per il montaggio dei componenti nuovi sono a carico dell'acquirente. Sono escluse pretese di risoluzione per vizi, di riduzione o ulteriori pretese di risarcimento danni.

Garantie NL

Zichtbare gebreken moeten binnen de 8 dagen na ontvangst van de goederen worden gemeld, zo niet verliest de verkoper elke aanspraak op grond van deze gebreken. Onze machines worden geleverd met een garantie voor de duur van de wettelijke garantietermijn. Deze termijn gaat in vanaf het moment dat de koper de machine ontvangt. De garantie houdt in dat wij elk onderdeel van de machine dat binnen de garantietermijn aantoonbaar onbruikbaar wordt als gevolg van materiaal- of productiefouten, kosteloos vervangen. De garantie vervalt echter bij

verkeerd gebruik of verkeerde behandeling van de machine. Voor onderdelen die wij niet zelf produceren, geven wij enkel de garantie die wij zelf krijgen van de oorspronkelijke leverancier. De kosten voor de montage van nieuwe onderdelen vallen ten laste van de koper. Eisen tot het aanbrengen van veranderingen of het toestaan van een korting en overige schadeloosstellingsclaims zijn uitgesloten.

Garantía ES

Los defectos evidentes deberán ser notificados dentro de 8 días después de haber recibido la mercancía, de lo contrario el comprador pierde todos los derechos sobre tales defectos. Garantizamos nuestras máquinas en caso de manipulación correcta durante el plazo de garantía legal a partir de la entrega. Sustituiremos gratuitamente toda pieza de la máquina que dentro de este plazo se torne inútil a causa de fallas de material o de fabricación. Las piezas que no

son fabricadas por nosotros mismos serán garantizadas hasta el punto que nos corresponda garantía del suministrador anterior. Los costes por la colocación de piezas nuevas recaen sobre el comprador. Están excluidos derechos por modificaciones, aminoraciones y otros derechos de indemnización por daños y perjuicios.

Garantia PT

Para este aparelho concedemos garantia de 24 meses. A garantia cobre exclusivamente defeitos de material ou de fabricação. Peças avariadas são substituídas gratuitamente. cabe ao cliente efetuar a substituição. Assumimos a garantia unicamente de peças genuínas. Não há direito à garantia no caso de: peças de desgaste, danos de transporte, danos causados

pelo manejo indevido ou pela desatenção as instruções de serviço, falhas da instalação elétrica por inobservância das normas relativas á electricidade. Além disso, a garantia só poderá ser reinvidicada para aparelhos que não tenham sido consertados por terceiros. O cartão de garantia só vale em conexão com a fatura.

Garanti NO

Åpenbare mangler skal meldes innen 8 dager etter at varen er mottatt, ellers taper kunden samtlige krav pga slik mangel. Vi gir garanti for at våre maskiner ved riktig behandling under den rettslige garanti tidens varighet, fra overlevering, på den måten at vi erstatter kostnadsfritt hver maskindel, som innen denne tiden påviselig er ubrukelig som følge av material- eller

produksjonsfeil. For deler som vi ikke produserer selv, yter vi garanti kun i den utstrekning som garantikrav mot underleverandør tilkommer oss. Kjøperen bærer kostnadene ved montering av nye deler. Endrings- og verditapskrav og øvrige skadeerstatningskrav er utelukkede.

Takuu FI

Ilmeisistä puutteista tulee ilmoittaa kahdeksan päivän kuluessa tavaran vastaanottamisesta. Muutoin ostaja ei voi vaatia korvausta ko. puutteista. Annamme takuun oikein käsitellyille koneillemme lakisääteiseksi takuujaksiksi tavaran luovutuksesta alkaen siten, että vaihdamme korvauksetta minkä tahansa koneenoson, joka osoittautuu tämän ajan kuluessa käyttökelvot-

tomaksi raaka-aine- tai valmistusvirheestä johtuen. Osille, joita emme valmista itse, annamme takuun vain mikäli osien toimittaja on antanut niistä takuun meille. Uusien osien asennuskustannukset maksaa ostaja. Purku- ja vähennysvaatimukset ja muut vahingonkorvausvaatimukset eivät tule kysymykseen.

Garanti SE

Med denna maskin följer en 24 månaders garanti. Garantins täcker endast material- och konstruktionsfel. Defekta delar ersätts utan omkostningar, men kunden står för installationen. Vår garanti täcker endast original-delar. Anspråk på garanti öreligger inte för: garantin täcker ej,

transportskador, skador orsakade av felaktig behandling och då skötsel föreskrifter inte beaktats. Vidare kan garantikrav endast ställas för maskiner som inte har reparerats av tredje part.

Záruka SK

Zrejme vady musia byť predstavené v priebehu 8 dni po obdržaní tovaru, ináč zákazník stratí všetky nároky týkajúce sa takejto vady. Ponúkame záruku na naše aparáty, ktoré sú správne používané počas zákonného termínu záruky tak, že bezplatne vymeníme každú časť aparátu, ktorá sa v priebehu tohto času môže stať dokázateľne nefunkčnou dôsledkom materiálnej či

výrobnej vady. Na časti ktoré sami nevyrobíme, poskytujeme záruku iba v rozsahu, v ktorom nám prísluší nárok na záručné plnenie k subdodávateľovi. Za trovy týkajúce sa inštalácie nových súčiastky je zodpovedný zákazník. Nárok na výmenu tovaru, na zľavu a iné nároky na nahradenie škody sú vylúčené.

Garancija SI

Očitne pomanjkljivosti je potrebno naznaniti 8 dni po prejemu blaga, v nasprotnem primeru izgubi kupec vse pravice do garancije zaradi takšnih pomanjkljivosti. Za naše naprave dajemo garancijo ob pravilni uporabi za čas zakonsko določenega roka garancije od prodaje in sicer na takšen način, da vsak del naprave brezplačno nadomestimo, za katerega bi se v tem roku

izkazalo, da je zaradi slabega materiala ali slabe izdelave neuporaben. Za dele, ki jih sami ne izdelujemo, jamčimo samo toliko, kolikor zahteva garancija drugih podjetij. Stroški za vstavljanje novih delov nosi kupec. Zahteve za spreminjanje in zmanjšanje ter ostale zahteve za nadomestilo škode so izključene.

Szavatosság HU

A nyilvánvaló hibákat ki kell jelenteni számított 8 napon belül az áruk, különben a vevő elveszti minden igényt az ilyen hibák. Kínálunk garanciát a gépeinket a megfelelő kezelés időtartamának hallgatólagos garancia a szállítás időpontját oly módon, hogy cserélje ki minden egyes része ezen idő alatt észlelhető a sorban anyag-vagy gyártási legyen hiábavaló, ingyen. Az alkatrészeket, hogy

nem termel magunkat, hogy csak olyan garanciát, hiszen jogosultak jótállási igények beszállítókkal szemben. A költségek beillesztése az új részek a vevőnek. Átalakítása és csökkentése követelések és egyéb kártérítési igények ki vannak zárva.

Garancija HR

Vidljive štete se moraju prijaviti u roku od 8 dana od primitka robe. U suprotnom slučaju kupac gubi pravo na reklamaciju. Mi jamčimo za naše strojeve u slučaju ispravnog postupanja tijekom perioda zakonskog jamstva tako što zamijenjujemo besplatno bilo koji dio stroja koji dokazano postane neupotrebljiv uslijed neispravnog materijala ili grešaka u proizvodnji u tom vremenskom

periodu. Za dijelove koje mi nismo proizveli jamčimo samo ukoliko imamo pravo na reklamaciju prema dobavljačima. Troškove za ugradnju novih dijelova snosi kupac. Molbe za smanjenjem cijene kao i sve druge reklamacije zbog šteta su isključene.

Záruka CZ

Viditelné vady jsou poukazatelné během 8 dní od obdržení zboží, jinak ztrácí zákazník všechny nároky týkající se takovýchto vad. Poskytujeme záruku na naše stroje, s kterými je správně zacházeno, na dobu zákonně záruční lhůty začínající od doručení tak, že bezplatně vyměníme každou část stroje, která se během této doby může stát prokazatelně nepoužitelnou následkem

materiálové či výrobní vady. Na díly, které sami neopravujeme, poskytujeme záruku pouze v rozsahu, v němž nám přísluší nárok na záruční plnění vůči subdodavateli. Náklady na instalaci nového dílu nese zákazník. Nárok na výměnu zboží, na slevu a jiné nároky na odškodnění jsou vyloučené.

Gwarancja PL

Wszelkie uszkodzenia muszą być zgłaszane w przeciagu 8 dni od daty otrzymania towaru, w przeciwnym wypadku, prawo do reklamacji wygasa. Gwarantujemy, że w czasie trwania gwarancji wymienimy wszelkie części maszyny, które okażą się niesprawne na skutek wad materiału z jakiego zostały wykonane lub błędów w produkcji bez dodatkowych opłat pod warunkiem, że maszyna

będzie obsługiwana zgodnie z zaleceniami. W odniesieniu do części nie produkowanych przez nas, gwarancja obowiązuje tylko w przypadku naszych dostawców. Koszty instalacji nowych części są ponoszone przez klienta. Odszkodowania wynikłe z uszkodzeń maszyny oraz redukcje ceny zakupu maszyny w ramach reklamacji nie będą rozpatrywane.

Garantie RO

Defecte evidente trebuie să fie raportate în termen de 8 zile de la primirea de bunuri, altfel cumpărătorul pierde toate cererile pentru astfel de defecte. Oferim o garanție de pe mașinile noastre cu un tratament adecvat pe durata unei garanții implicite de la data de livrare în așa fel încât vom înlocui fiecare parte în acel moment detectabil într-un rând în material sau manoperă ar fi inutil, gratuit. Pentru părțile care nu ne pro-

duc, vom face doar o astfel de garanție, așa cum avem dreptul la pretenții de garanție împotriva furnizorilor. Costurile pentru introducerea de piese noi la cumpărător. Conversie și reducerea creanțe și alte cererile de despăgubire sunt excluse.

Garantii EE

Ilmselgetest vigadest tuleb teatada 8 päeva jooksul pärast kauba kättesaamist, vastasel juhul kaotab ostja kõik õigused garantiile nimetatud vigade tõttu. Õige käsitsemise korral anname oma masinatele garantii seadusega ettenähtud ajaks alates kauba üleandmisest nii, et vahetame tasuta välja kõik masina osad, mis nimetatud aja jooksul peaks muutuma kasutuskölbmatuks

materjali- või tootmisvea tõttu. Osade eest, mida me ise ei tooda, anname garantii vaid selles osas, mis tarnija on meile garanteerinud. Uute osade paigaldamise kulud kannab ostja. Muutmis- ja amortisatsiooninõuded ning muud kahjutasunõuded välistatakse.

Garantija LV

Acīmredzami defekti ir jāpaziņo 8 dienu laikā no preces saņemšanas. Pretējā gadījumā pircēja tiesības pieprasīt atbilstību par šādiem defektiem ir spēkā neesošas. Mēs dodam garantiju savām iekārtām, ja pircējs pret tām atbilstoši izturas garantijas laikā. Mēs apņemamies bez maksas piegādāt jebkuru rezerves daļu, kas iespējams kļuvusi nelietoājama bojātu materiālu vai ražošanas defektu dēļ šajā laika periodā. Attiecībā uz rezerves daļām, kuras nav mūsu ražotas, mēs garantējam

tikai gadījumā, ja mums ir garantija no saviem piegādātājiem. Jauno detaļu uzstādīšanas izmaksas ir jāuzņemas pircējam. Pirkuma atcelšana vai pirkuma cenas samazināšana, kā arī jebkuras citas prasības par bojājumu atbilstināšanu netiek izskatītas.

Garantija LT

Dėl akivaizdžiai matomų defektų turi būti informuota per 8 dienas nuo įrenginio gavimo momento. Kitu atveju pirkėjo teisė reikšti pretenziją dėl šių defektų yra negaliojanti. Savo įrenginiams mes garantuojame įstatymo nustatytą pilną aptarnavimą garantinio laikotarpio metu, jei yra laikomasi gamintojo-vartotojo susitarimo ir mes pažadame nemokamai pakeisti bet kurias mašinos dalis,

sugedusias dėl blogos medžiagos ar gamyklinio broko. Mes neatsakome už dalis, pagamintas ne mūsų ir jūsų gautas iš kito tiekėjo. Naujų dalių montavimo kaštai yra pirkėjo atsakomybė. Pirkimo nutraukimas ar pirkimo kainos sumažinimas, kaip ir bet kurios kitos pretenzijos dėl nuostolių nebus patenkinamos.

Abyrgð IS

Augljósar skemmdir verður að tilkynna innan 8 daga frá viðtöku vörunnar. Annars er réttur kaupanda um bætur vegna sílka skemmda ógildur. Við ábyrgjumst, í tilfelli rétttrar meðhöndlunar yfir lögbundið ábyrgðartímabil frá afhendingu, að við skiptum um hvern vélarhlut án kostnaðar sem ónothæfur er vegna gallaðs efnis eða skemmda í framleiðslu innan ákveðins tímabils. Af því er

tekur til hluti sem ekki eru framleiddir af okkur, ábyrgjumst við af því leiti aðeins að við eigum rétt á ábyrgðarkröfum gagnvart birgðasöllum. Kostnaður vegna uppsetningar á nýjum hlutum skal falla í skaut kaupanda. Ógilding sölu eða afsliáttur á kaupverði sem og aðrar kröfur vegna skemmda eru undanskildar.

Garanti TR

Apaçık kusurları malların alınmasından 8 gün içinde bildirilmesi gerekir, aksi takdirde alıcı bu kusurları için tüm talepler kaybeder. Biz ücretsiz, yarasız olmalıdır malzeme veya işçilik üst üste saptanabilir bu süre içinde her bir parça takmadan böyle bir şekilde teslim tarihinden itibaren zimmi garanti süresine uygun tedavi ile makinelerde bir garanti veriyoruz. Biz tedarikçiler karşı garanti

talepleri hakkı olarak kendimizi üretmek değil bu parça için, biz, sadece teminat olun. Alıcıya yeni parçaların yerleştirilmesi için maliyetleri. Dönüşüm ve azaltma iddiaları ve diğer tazminat talepleri dahil değildir.

гаранция BG

Очевидни недостатъци трябва да бъдат докладвани в рамките на 8 дни от получаването на стоки, в противен случай купувачът губи всякакви претенции за такива дефекти. Предлагаме гаранция на нашите машини с правилното лечение на срока на действие на косвена гаранция от датата на доставка по такъв начин, че ние замени всяка част в рамките на това време открива в един ред в материала или изработката трябва да бъде безполезно,

безплатно. За части, които ние не се произвеждат, ние правим само като гаранция, като имаме право на гаранционни искове срещу доставчици. Разходите за вмякване на нови части на купувача. Преобразуване и намаляване вземания и други искове за обезщетения, са изключени.

Гарантия RU

Об очевидных дефектах необходимо уведомить в течение 8 дней после получения товара. В ином случае все претензии покупателя по таким дефектам не принимаются. Мы предоставляем гарантию на наши машины при условии правильного обращения с ними. Гарантия действует с момента передачи машины в течение установленного законом гарантийного срока. В течение этого времени мы гарантируем бесплатную замену любой части машины, если они стали непригодны к использованию в результате доказуемых ошибок в применяемых

материалах или при изготовлении. На части машины, которые мы не изготавливаем сами, мы предоставляем гарантии в той мере, насколько нас касаются рекламационные претензии к изготовителям. Расходы по замене деталей несет покупатель. Претензии на расторжение договора купли-продажи, штрафы и прочие требования о возмещении ущерба исключаются.

Garantie BE-VLG

Zichtbare gebreken moeten binnen 8 dagen na ontvangst van de goederen worden gemeld, anders verliest de koper elk recht op aanspraak voor dergelijke gebreken. Bij een juiste behandeling van onze machines en gedurende de wettelijke garantietermijn vanaf de aflevering bieden wij garantie door elk machineonderdeel, dat tijdens deze periode door materiaal- of

productiefouten onbruikbaar zou worden, gratis te vervangen. Voor onderdelen die wij niet zelf produceren, bieden wij enkel garantie in de mate die de toeleveranciers ons bieden. De kosten voor de plaatsing van de nieuwe onderdelen draagt de koper. Aanspraken voor wijzigingen, waardevermindering en overige schadeloosstelling zijn uitgesloten.