

mira

event xs

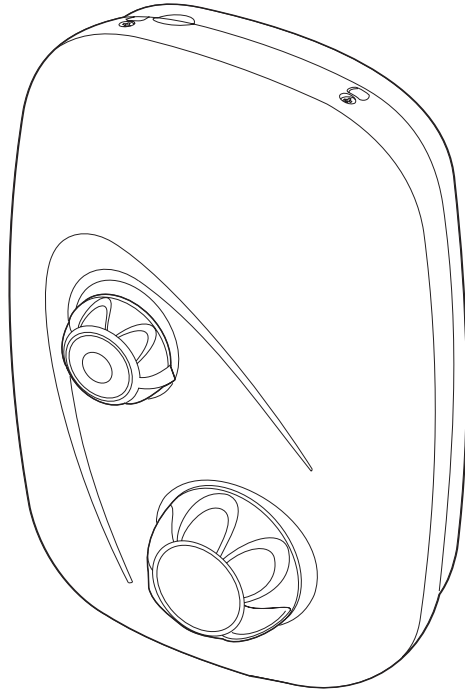

MIRA EVENT XS

MANUAL POWER SHOWER

Installation and User Guide

These instructions are to be left with the user

CONTENTS

Introduction	3
Guarantee	3
Recommended Usage.....	3
Important Safety Information	4
Pack Contents Checklist	6
Dimensions	7
Specifications	8
1. General.....	8
2. Plumbing	8
3. Electrical.....	9
4. Standards.....	9
Installation Requirements	10
1. General.....	10
2. Electrical.....	10
3. Plumbing	11
4. Installation Diagrams.....	13
Installation	14
1. Before You Start	14
2. Configuring Inlet Supplies	15
3. Shower Installation.....	17
Commissioning	21
1. General Commissioning	21
Operation	22
Fault Diagnosis.....	23
1. User Maintenance	23
2. Installer Maintenance	24
Maintenance.....	26
Wiring Diagram.....	30
Spare Parts	31
Accessories	32
Notes	33
Customer services	36

INTRODUCTION

Thank you for purchasing a quality Mira product. To enjoy the full potential of your new shower, please take time to read this guide thoroughly, and keep it handy for future reference.

The Mira Event XS is a surface mounted all-in-one manual power shower. It is designed for use with a mains voltage electrical supply and gravity fed hot and cold water supplies. It features a built-in pump unit, manual mixer assembly and separate controls for flow and temperature.

The product is fitted with a 15 mm dual entry push-fit inlet manifold which allows pipe connections to the top, bottom or rear of the power shower. The inlet manifold also contains inlet filters and check valves.

The shower control is supplied with Mira Logic power shower fittings. These fittings consist of an adjustable spray handset with four different spray actions (start, champagne, massage and economy), flexible hose, adjustable clamp bracket assembly, slide bar and supports, hose retaining ring and wall mounted soap dish. The fittings are available in a white/chrome or all white finish.

The Mira Event XS is not suitable for use in institutional/commercial applications. It **must not** be used with mains water pressure applications; for example, instantaneous electric heaters, instantaneous gas water heaters, unvented mains pressure systems, pumped shower systems and some combination-type storage systems.

Guarantee

Mira Showers guarantee the Mira Event XS against any defect in materials or workmanship for a period of **one** year from the date of purchase.

For terms and conditions refer to the back cover of this guide.

Recommended Usage

Domestic	✓
Light Commercial	✓
Heavy Commercial	✗
Healthcare	✗

Patents

UK: 2 340 210, 2 392 223, 2 392 224, 2 392 225, 2 421 297

USA: 7 240 850

Patent Applications:

Euro: 03254070.0

USA: 2007-0221740-A1

If you experience any difficulty with the installation or operation of your new power shower, please refer to '**Fault Diagnosis**' before contacting Kohler Mira Limited. Our contact details can be found on the back cover of this guide.

IMPORTANT SAFETY INFORMATION

1. Warning!

- 1.1. Products manufactured by us are safe and without risk provided they are installed, used and maintained in good working order in accordance with our instructions and recommendations.
- 1.2. **THIS APPLIANCE MUST BE EARTHED. ENSURE SUPPLEMENTARY BONDING COMPLIES WITH THE "REQUIREMENTS FOR ELECTRICAL INSTALLATIONS".**

In accordance with the current edition of 'The Plugs and Sockets etc. (Safety Regulations)' in force at the time of installation, the Mira Event XS is intended to be permanently connected to the fixed electrical wiring of the mains system.
- 1.3. **DO NOT** connect the Mira Event XS to a mains-fed water supply. Such a connection will damage the Mira Event XS, and is not covered under the manufacturer's guarantee.
- 1.4. The Mira Event XS must not be fitted where it may be exposed to freezing conditions. Make sure that any pipework that could become frozen is properly insulated.
- 1.5. **DO NOT** operate the Mira Event XS if it is frozen. Allow the Mira Event XS to thaw before using again.
- 1.6. **DO NOT** operate the Mira Event XS if water leaks from the unit, maintenance will be required before the Mira Event XS can be safely used.
- 1.7. **DO NOT** allow the Mira Event XS to be run dry.
- 1.8. **DO NOT** fit any form of outlet flow control. Only Mira recommended outlet fittings should be used.
- 1.9. There are no user serviceable components beneath the cover of the Mira Event XS. Only a competent tradesperson should remove the cover.
- 1.10. If any of the following conditions occur, isolate the electricity and water supplies and refer to "**To contact us**", on the back page of this guide.
 - 1.10.1. If the cover is not correctly fitted and water has entered the case.
 - 1.10.2. If the case is damaged.
 - 1.10.3. If the Mira Event XS begins to make an odd noise, smell or smoke.
 - 1.10.4. If the Mira Event XS shows signs of a distinct change in performance, indicating a need for maintenance.
 - 1.10.5. If the Mira Event XS is frozen.
- 1.11. Turn off the electrical and water supplies before removing the cover. The electricity must be turned off at the mains and, if applicable, the appropriate circuit fuse removed.
- 1.12. Mains connections are exposed when the cover is removed.
- 1.13. Moving parts are exposed when the cover is removed.
- 1.14. Ensure all electrical connections are tight, to prevent overheating.

- 1.15.** Make a note of the layout of the wire runs and connections before removal, make sure that they are replaced and connected as noted.

2. Caution!

2.1. Read all of these instructions and retain this guide for later use.

- 2.2.** Pass on this guide in the event of change of ownership of the installation site.
- 2.3.** Follow all warnings, cautions and instructions contained in this guide.
- 2.4.** Follow all warnings, cautions and instructions contained on or inside the Mira Event XS.
- 2.5.** The electrical installation must comply with the “Requirements for Electrical Installations” commonly referred to as the IEE Wiring Regulations, or any particular regulations and practices specified by the local electricity supply company, in force at the time of installation. The installation should be carried out by an electrician or contractor who is registered or is a member of an association such as:
 - 2.5.1.** National Inspection Council for Electrical Installation and Contracting (NICEIC), throughout the UK.
 - 2.5.2.** The Electrical Contractors Association (ECA), England and Wales.
 - 2.5.3.** The Electrical Contractors Association of Scotland (ECAS).
- 2.6.** The plumbing installation must comply with Water Supply Regulations/Bye-laws (Scotland), Building Regulations or any particular regulations and practices, specified by the local water company or water undertakers. The installation should be carried out by a plumber or contractor who is registered, or is a member of, an association such as:
 - 2.6.1.** Institute of Plumbing (IOP), throughout the UK.
 - 2.6.2.** National Association of Plumbing, Heating and Mechanical Services Contractors (NAPH & MSC), England and Wales.
 - 2.6.3.** Scottish and Northern Ireland Plumbing Employers’ Federation (SNIPEF), Scotland and Northern Ireland.
- 2.7.** Anyone who may have difficulty understanding or operating the controls of any shower should be attended whilst showering. Particular consideration should be given to the young, the elderly, the infirm, or anyone inexperienced in the correct operation of the controls.
- 2.8.** Children should be supervised to ensure that they do not play with the appliance.
- 2.9.** Sunburn or skin conditions can increase your sensitivity to hot water. Make sure that you set the shower to a cooler temperature.
- 2.10.** When the Mira Event XS has reached the end of its serviceable life, it should be disposed of in a safe manner, in accordance with current local authority recycling, or waste disposal policy.

PACK CONTENTS CHECKLIST

Tick the appropriate boxes to familiarise yourself with the part names and to confirm that the parts are included.

1 x Event XS M Manual Power Shower

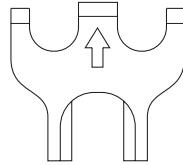
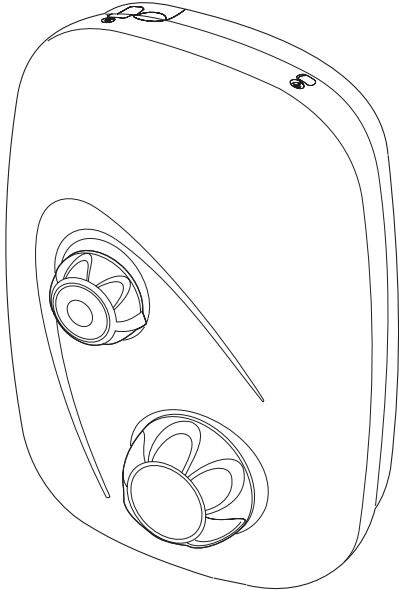

1 x Push-Fit Release Tool

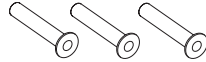

3 x Rubber Wall Plugs



3 x Fixing Screws



3 x Rubber Feet

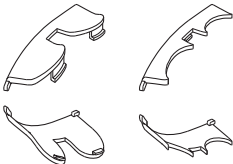

4 x Case Inserts

Documentation

- 1 x Guarantee Registration Document
- 1 x Installer/Product Check List

DIMENSIONS

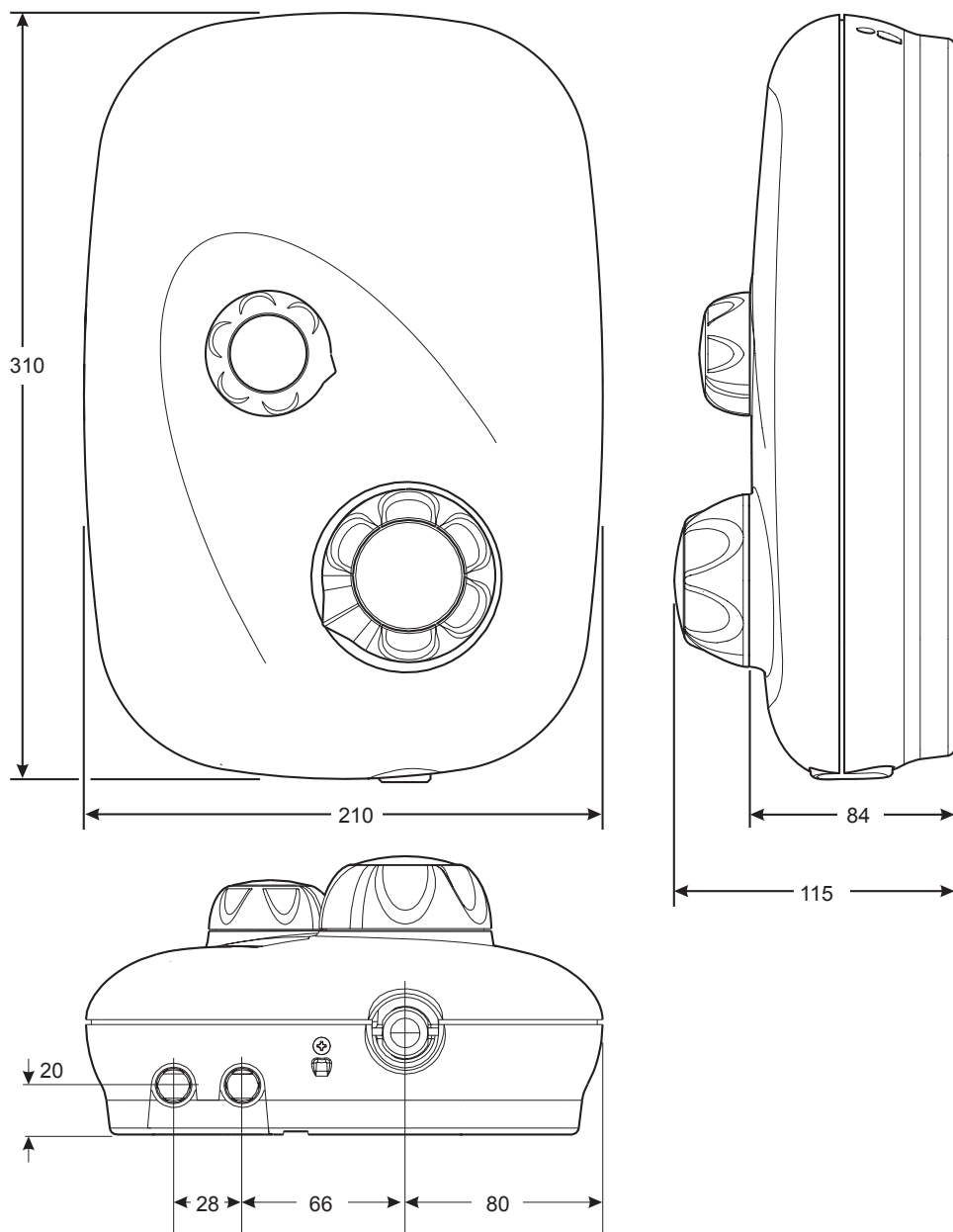

All dimensions in millimetres

SPECIFICATIONS

1. General

- 1.1. **Ambient temperature** – Maximum recommended ambient temperature for the appliance is 30°C.
- 1.2. **Maximum recommended hot water temperature** – 65°C.
Warning! For safety reasons set the maximum stored hot water temperature to between 60 and 65°C. Such temperatures are considered sufficient to meet all normal requirements and will also minimise the deposition of scale in hard water areas.
- 1.3. **Temperature control** - To obtain full performance the Mira Event XS should be installed, operated and maintained in accordance with this guide.
- 1.4. **Maximum static inlet pressure** - 1 bar or 10 m (supplies must be gravity-fed at nominally equal pressures). Refer to section: '**Installation Requirements, Plumbing**'.
- 1.5. **Maximum recommended inlet pressure** - 0.5 bar or 5 m.
- 1.6. **Minimum static inlet pressure** - 0.008 bar or 80 mm (required to prime the integral centrifugal pump). The minimum static pressure will increase for long supply pipe lengths. Refer to section: '**Installation Requirements, Plumbing**'.
- 1.7. Minimum Flow Rate - 8 l/Min (with a static inlet pressure of 0.1 bar).
Maximum Flow Rate - 16 l/Min (with a static inlet pressure of 0.1 bar).
Flow Rates may vary due to differences in supply pressures.
- 1.8. **Duty Cycle** - The Mira Event pump is continuously rated. The motor is fitted with a self-resetting thermal trip, designed to operate if motor temperatures become too high due to abnormally high supply voltages.
- 1.9. **Noise** - The Mira Event XS is supplied with anti-vibration rubber feet and rubber wall plugs that isolate the unit from the wall in order to minimize the amount of noise transmitted. The type of wall the Mira Event XS is fixed to will also affect the perceived noise level; solid walls will provide a quieter operation.

2. Plumbing

- 2.1. **Inlet** – 15 mm Push-fit inlet manifold.
- 2.2. **Outlet** – 1/2" BSP to BS2779.

3. Electrical

- 3.1. Appliance power supply** – 230–240 V, 50 Hz, fused at 3 Amps, via a double pole switched fused connection unit (not supplied) with a minimum 3 mm contact separation in each pole.
- 3.2. Power supply connection** – The Mira Event XS is fitted with a terminal block which will accept cable up to 2.5 mm². Minimum cable size (cross-sectional area) required under normal installation conditions is 1 mm².
- 3.3. Absorbed power** - Approximately 150 W under normal working conditions.

4. Standards

- 4.1.** The Mira Event XS complies with all relevant directives for CE marking.

INSTALLATION REQUIREMENTS

1. General

- 1.1. **Do not** take risks with plumbing or electrical equipment.
- 1.2. **Do not** install the Mira Event XS in a position where it could become frozen.
- 1.3. Isolate electrical and water supplies before proceeding with the installation of the Mira Event XS.
- 1.4. The shower control **must** be fed from a cold water storage cistern and hot water cylinder providing nominally equal pressures.
- 1.5. The installation must be carried out by a competent installer.
- 1.6. Decide on a suitable position for the Mira Event XS (minimum distance of 200 mm from the ceiling to allow for fitting and removal of the cover). The position of the Mira Event XS and the shower fittings must provide a minimum gap of 25 mm between the spillover level of the shower tray/bath and the handset. This is to prevent back siphonage.
- 1.7. The Mira Event XS must be fitted onto the finished wall surface i.e. on top of the tiles. **Do not** fit the Mira Event XS to the wall and then tile up to the sides of the casing. (Small pillars moulded on the back of the case allow air to circulate and water to drain from behind the appliance).
- 1.8. When fitting the Mira Event XS with wall entry inlet supplies it is recommended that the supply pipework is sealed to the wall to prevent water from leaking back into the wall.
- 1.9. In solid wall installations the supply pipework should be installed within ducting to allow some free lateral movement when making supply connections.

2. Electrical

- 2.1. **Do not turn on the electrical supply until the plumbing has been completed.**
- 2.2. The mains supply must be 230-240 V at 50 Hz connected to the appliance via a double pole switched 3 Amp fused connection unit (not supplied) with a minimum 3 mm contact separation gap in each pole.
- 2.3. Fuses do not give personal protection against electric shock.
- 2.4. The Mira Event XS **must be earthed** by connecting the supply-cable earth conductor to the earth terminal.
Supplementary bonding: Within the bathroom or shower room, all accessible conductive parts of electrical equipment and extraneous conductive parts that are likely to introduce earth potential, must be electrically bonded to earth using a minimum cable size of 4.0 mm² if the cable is not mechanically protected (2.5 mm² if mechanically protected).
- 2.5. The minimum cable size (cross-sectional area) required is 1 mm² under normal conditions of installation.

- 2.6.** A 30mA residual current device (RCD) must be fitted. This may be part of the consumer unit or a separate unit.

3. Plumbing

- 3.1.** **Do not** use excessive force when making connections to the flexible hoses or handset, finger tightness is sufficient.
- 3.2.** **Do not** solder supply pipework with the Mira Event XS connected. Heat transmitted through the pipework will melt the inlet manifold.
- 3.3.** The storage cistern should have a minimum storage capacity of 230 litres to provide adequate showering time. Insufficient storage may result in the pump being run dry.
- 3.4.** Avoid layouts where the hose will be sharply kinked. This may reduce the life of the hose.
- 3.5.** No form of flow control should be fitted to the outlet of the appliance.
- 3.6.** Fit non-restrictive (free-flowing) isolating valves to the inlet pipework in an easily accessible position. These valves will allow the water supply to be turned off to the Mira Event XS, for maintenance purposes.
- 3.7.** When using surface mounted inlet supply pipework the use of polyethylene plastic pipe suitable for hot water is recommended to enhance the appearance of the finished installation. Internal pipe supports (not supplied) should be used with this type of pipe.
- 3.8.** Only use the Mira showerhead supplied with this appliance.
- 3.9.** If the appliance is installed on a common supply ensure the appliance is the first take-off from the supply and is not influenced by the operation of any other appliance.
- 3.10.** If the appliance is installed on a common supply which feeds an adjacent tap, the maximum static inlet pressure for the appliance will, under certain circumstances, be exceeded. The action of closing the tap can cause a pulse in the supply pressure which will result in damage to the appliance. This can be resolved by the installation of a suitably sized mini expansion vessel, sited as close as possible to the tap and pressurised to 0.5 bar.
- 3.11.** Long pipe runs and excessive use of 90° elbows will significantly reduce the head available to supply the Event XS. If the effective head is less than **80 mm** then:
- 3.11.1** The expected flow rate may not be achieved.
- 3.11.2** Air may be drawn into the hot supply from the vent pipe, causing spluttering and temperature fluctuations at the handset.

Use the table below to calculate the actual head of water (x) needed in your installation.

A = Total length of 15 mm pipe in hot water supply pipe run*

B = Total length of 22 mm pipe in hot water supply pipe run*

C = Total length of 15 mm pipe in cold water supply pipe run*

D = Total length of 22 mm pipe in cold water supply pipe run*

*Measure from the base of the cold water cistern to the relevant inlet port on the Mira Event XS.

Size	Hot Water Supply			Cold Water Supply		
	Pipe Run / Qty of Elbows		Head Loss (mm)	Pipe Run / Qty of Elbows		Head Loss (mm)
15 mm Pipe	A x 120 x 120		C x 120 x 120	
22 mm Pipe	B x 20 x 20		D x 20 x 20	
15 mm Elbow	No of Elbows x 55		No of Elbows x 55	
22 mm Elbow	No of Elbows x 15		No of Elbows x 15	
	Add the minimum effective head required		+80	Add the minimum effective head required		+80
	Required head of water = x mm			Required head of water = x mm		

Example: With A = 1.5 m, B = 2.5 m, C = 2.2 m, D = 0 m.

Size	Hot Water Supply			Cold Water Supply		
	Pipe Run / Qty of Elbows		Head Loss (mm)	Pipe Run / Qty of Elbows		Head Loss (mm)
15 mm Pipe	A x 120	1.5 m x 120	180	C x 120	2.2 m x 120	264
22 mm Pipe	B x 20	2.5 m x 20	50	D x 20	0 m x 20	0
15 mm Elbow	No of Elbows	3 x 55	165	No of Elbows	3 x 55	165
22 mm Elbow	No of Elbows	2 x 15	30	No of Elbows	0 x 15	0
	Add the minimum effective head required		+80	Add the minimum effective head required		+80
	Required head of water = x mm		<u>505</u>	Required head of water = x mm		<u>509</u>

4. Installation Diagrams

To prevent operational difficulties, the feed from the cylinder should be as illustrated below. Side entry cylinder bosses are not recommended because:

- A drop in cylinder water level could expose a top entry immersion element if fitted.
- Air-in-water solution gathers at the edge of the cylinder and in the centre, during the heating process before travelling up the vent.

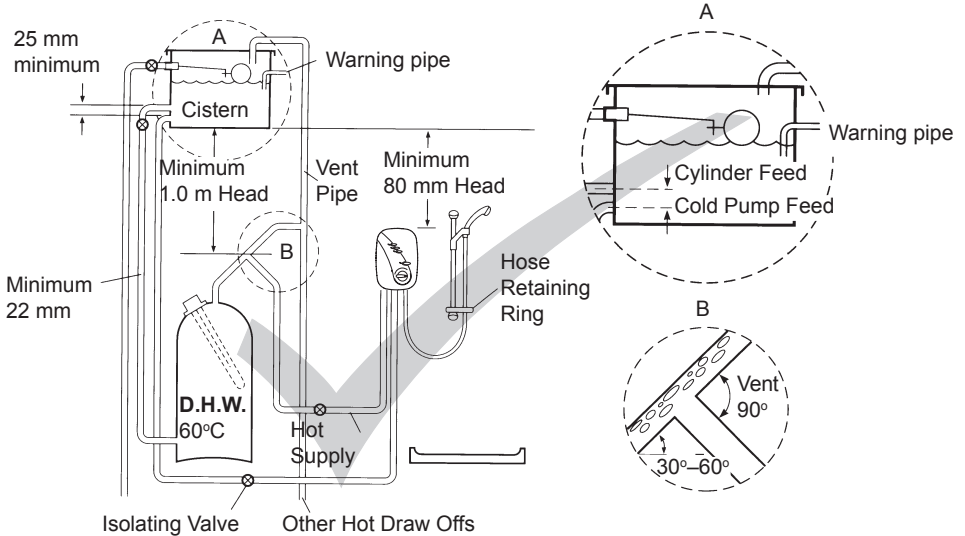

Correct Installation

A high level hot feed pipe run as illustrated below will result in air locking and should be avoided.

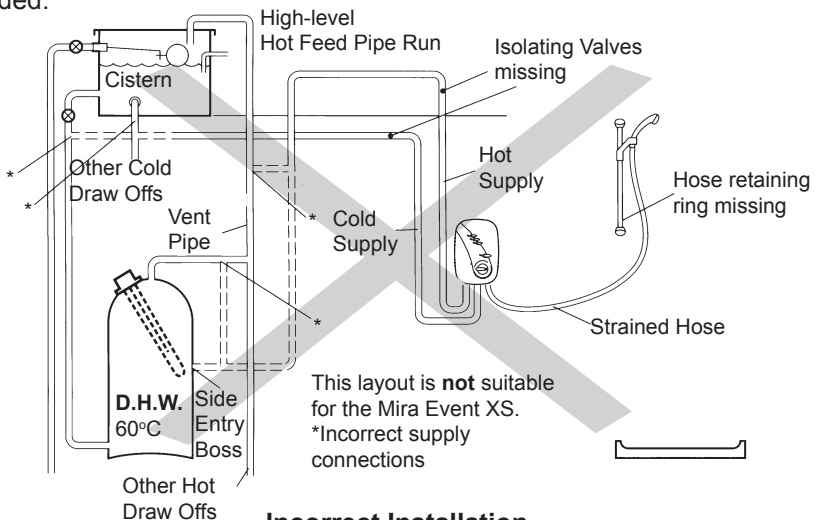

Incorrect Installation

INSTALLATION

1. Before You Start

Decide where to site the Mira Event XS power shower. It should be positioned at a height convenient for all the family. The fittings should be fitted so the handset sprays away from the Mira Event XS, either down the centre line of the bath or across the shower cubicle opening.

The Mira Event XS can support top, bottom or wall entry configurations for both the water and power supplies. Choose the appropriate configuration for your installation, refer to section: '**Configuring Inlet Supplies**'.

Falling Water
Supply Pipes

Falling Electrical Supply
(in miniature trunking)

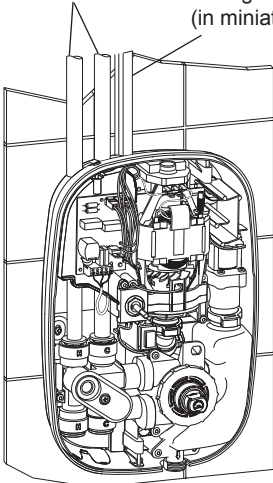

**Top Entry Supply
Configuration**

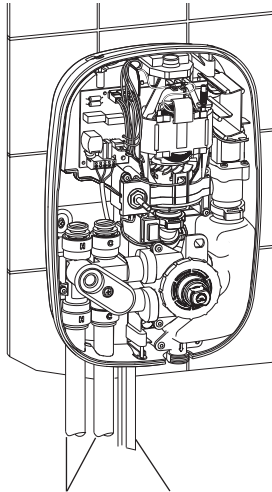

Rising Water
Supply Pipes

Rising Electrical Supply
(in miniature trunking)

**Bottom Entry Supply
Configuration**

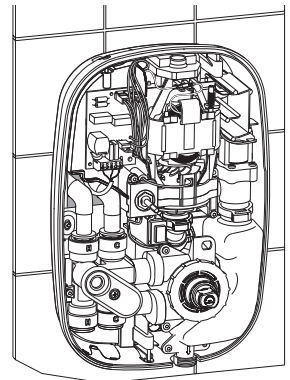

**Wall Entry Supply
Configuration**

2. Configuring Inlet Supplies

The Mira Event XS is supplied with blanking plugs fitted to all four ports of the inlet manifold. The pipework configuration will determine which blanking plugs and case inserts supplied must be fitted to the case.

Supply Pipework	Inlet Manifold Ports	Case Inserts
Top Entry Inlet	Fit blanking plugs to bottom ports of the inlet manifold.	Fit half insert in the top inlet of the case. Fit full insert in the bottom inlet of the case.
Bottom Entry Inlet	Fit blanking plugs to top ports of the inlet manifold.	Fit full insert in the top inlet of the case. Fit half insert in the bottom inlet of the case.
Wall Entry Inlet	Fit blanking plugs to bottom ports of the inlet manifold.	Fit full insert in the top inlet of the case. Fit full insert in the bottom inlet of the case.

The Mira Event XS allows for electrical cable entry from the top, bottom or back of the case. For top and bottom entries a thinned section of the case, covering the top or the bottom cable channel, must be removed before the cable can be fitted.

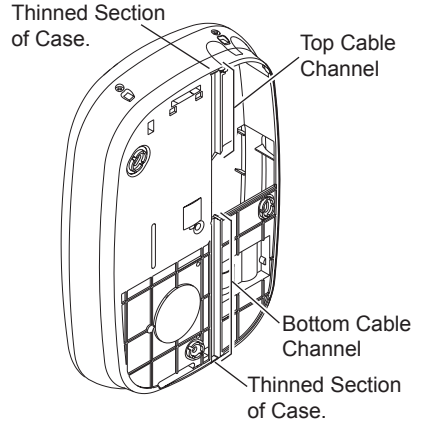
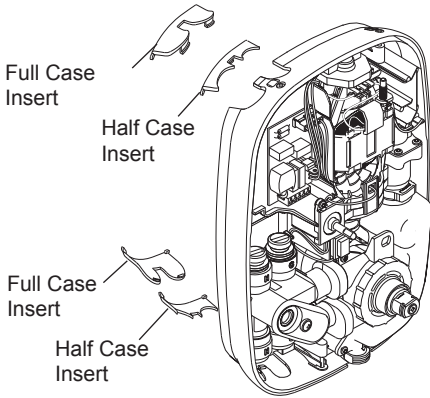

This procedure removes the top two blanking plugs from the inlet manifold for top or wall entry pipe configurations. Using this procedure as a guide, adjust the steps for bottom entry configurations as appropriate.

2.1. Remove the temperature knob concealing cap.

2.2. Use the push-fit release tool to lever off the temperature knob.

Note! It will be easier to lever off the temperature control knob with the push-fit release tool inserted under the knob directly below the temperature indicator.

2.3. Unscrew the three cover retaining screws sufficiently to remove the cover.

Note! The cover retaining screws are captive and need not be removed.

2.4. Insert the push-fit release tool between the flange of each of the blanking plugs and the collet of the inlet manifold, and lever the plugs outward. Whilst holding back on the collet, pull out each appropriate blanking plug by hand.

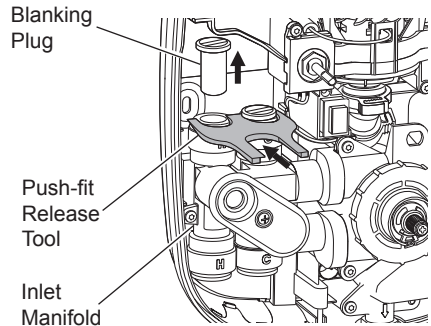
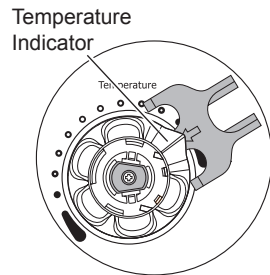
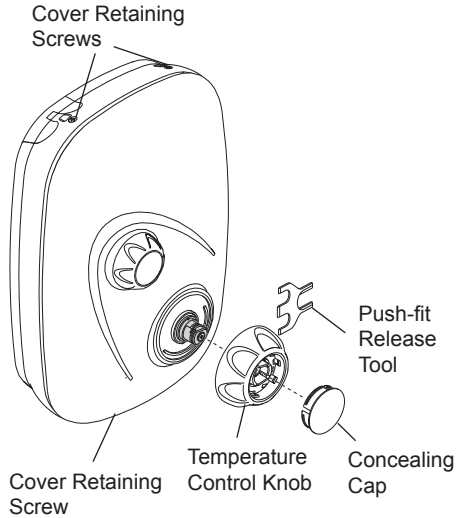

3. Shower Installation

The following installation procedure is based on a bottom entry pipework configuration (rising hot and cold water supplies) and a top entry electrical supply configuration (via miniature trunking from above). Using this procedure as a guide, adjust the steps for alternative water supply or electrical supply configurations as appropriate.

- 3.1. Decide on a suitable location for the Mira Event XS **avoiding buried cables and pipes**. Leave a **minimum distance of 200 mm from the ceiling** to allow for the fitting and removal of the cover. Ensure that when the hose retaining ring is placed on the lowest position on the slide bar, there is a **minimum distance of 25 mm between the handset and the bath or shower tray spillover** when the handset is hanging down.
- 3.2. Fit the three rubber feet into the recesses in the case as shown. The feet will reduce the noise transmitted by the power shower through the wall.
- 3.3. Remove the temperature knob concealing cap.
- 3.4. Insert the push-fit tool between the temperature control knob and cover directly under the temperature indicator and lever off the temperature knob.
- 3.5. Unscrew the three retaining screws sufficiently to remove the shower cover.

Note! The cover retaining screws are captive and need not be removed.

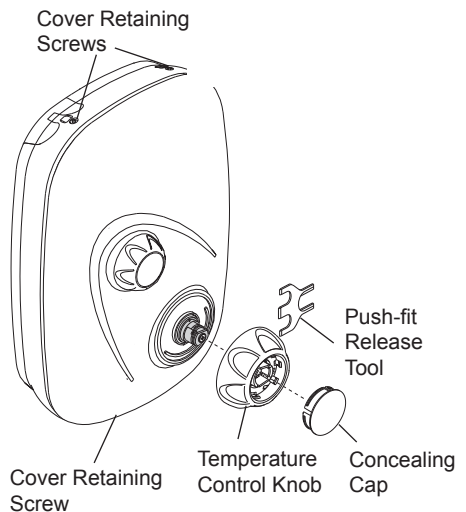
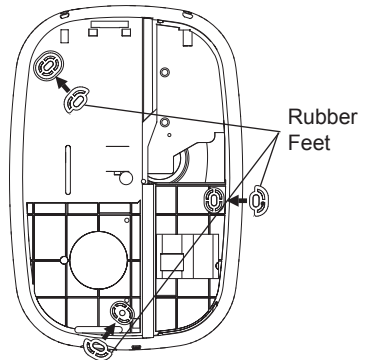
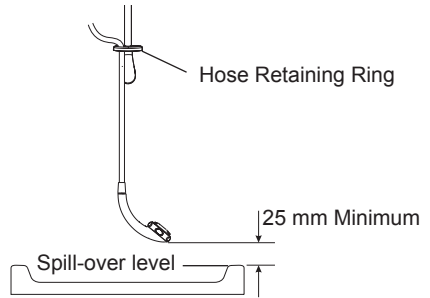

3.6. Using a spirit level position, the appliance on the wall, then mark through the three fixing points.

Tip! Special consideration should be given to the strength of the fixing arrangements when installing on to a dry lined, stud partition or dry partition wall structure. Installers may wish to obtain alternative proprietary cavity fixings, or choose other options such as fabricating rear supports using wooden blocks, however, these methods of fixing are beyond the scope of this guide.

Warning! Ensure the marked fixing points are not inline with buried cables and pipes before drilling.

3.7. Drill 9.5 mm holes and fit the rubber wall plugs supplied.

3.8. Cut away and trim the thinned section in the top of the case to allow the electrical supply cable to run down cable channel in the back of the case.

3.9. Run the electrical supply cable in surface mounted miniature trunking (not supplied). Allow sufficient cable to connect to the Mira Event XS terminal block (approximately 275 mm). Strip back approximately 30 mm of outer cable insulation.

3.10. Hot and cold inlet supply connections as marked are:

Hot – Left, Cold – Right

Note! Supply connections **must not** be connected in reverse.

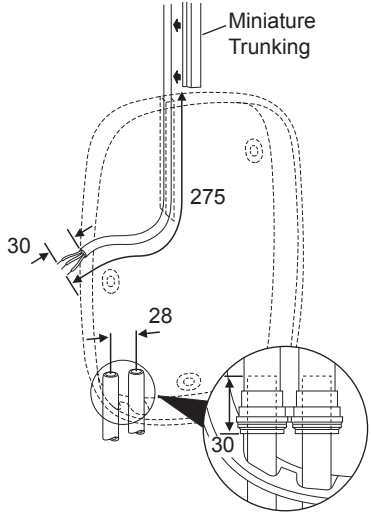
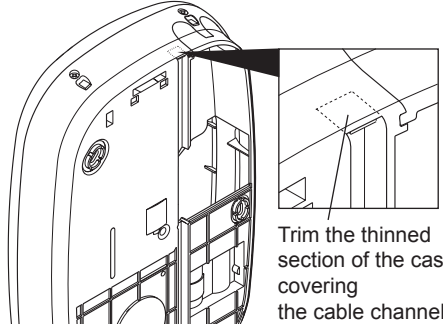
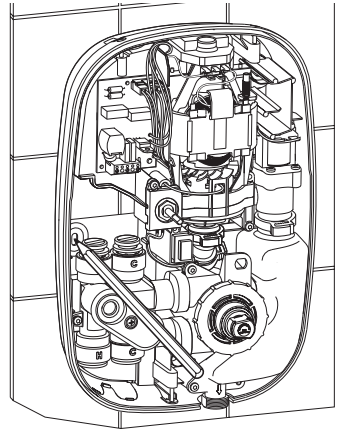

All dimensions in millimetres

Run the hot and cold water supply pipes at 28 mm centres, ensuring that the pipe ends project into the Mira Event XS by 30 mm to allow connection into the inlet manifold.

Caution! Do not use stainless steel piping for inlet pipework.

Caution! If chrome plated copper pipework is used then all traces of chrome plate must be removed from the connecting surfaces. If the chrome is not completely removed then the inlet manifold collet will fail to grip the supply pipe and the pipes will be forced out of the inlet manifold due to the water supply pressure.

- 3.11.** Ensure that the end of the supply pipework is cut squarely and **free from burrs** which can damage the inlet manifold seals.

Chamfer the end of the pipe to assist insertion into the fitting and prevent the 'O' seal tearing.

Note! PTFE tape or liquid jointing is **not** required to assist connection.

Warning! Do not insert fingers into the push-fit connectors as this can result in injury.

Caution! Thoroughly flush the incoming hot and cold water supply pipes to remove debris before connecting the Mira Event XS shower.

- 3.12.** Push the supply pipework inside the inlet manifold until resistance is felt. **DO NOT FORCE!**

- 3.13.** The collet and 'O' seal will automatically make a hydraulic seal.

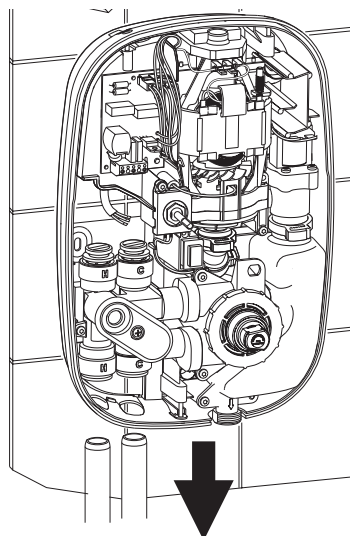
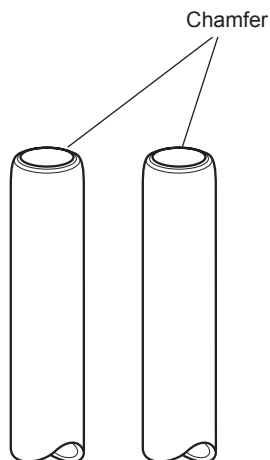

Important! This Mira Event XS **must** be fixed to the wall at all three fixing positions. The fixing holes are elongated to assist in vertical and horizontal alignment.

- 3.14.** Screw the Mira Event XS to the wall using either the supplied wall screws or alternative fixings depending on the wall structure.

Do not over-tighten!

Ensure that the electrical supply cable is correctly seated in the channel in the back of the case.

- 3.15.** Connect the conductors of the electrical supply cable to the terminal block. The supply cable earth connector should be sleeved.

- 3.16.** Turn the flow spindle fully clockwise so that the flat is facing towards 11 o'clock.

- 3.17** Turn the flow knob fully clockwise on the cover so that the indicator is pointing to the off position.

- 3.18** Refit the cover and secure with the three cover retaining screws.

- 3.19.** Refit the temperature control knob and the concealing cap.

- 3.20.** This completes the installation of the **Mira Event XS**. The appliance will now require commissioning. Refer to section: '**Commissioning**'.

- 3.21.** To install the **shower fittings**, refer to your shower fittings Installation and User Guide.

Flow Spindle

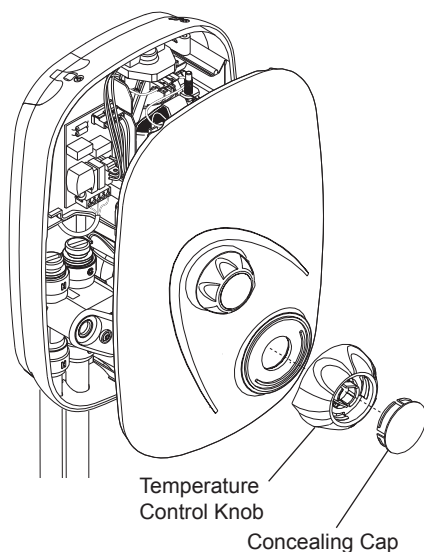
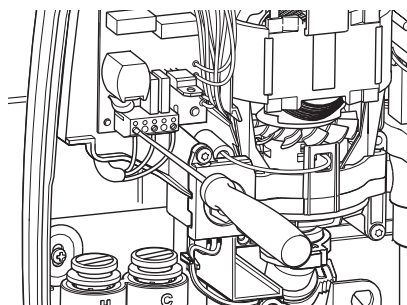
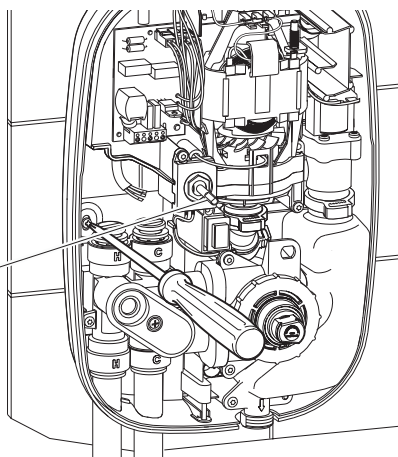

COMMISSIONING

1. General Commissioning

- 1.1. Make sure the flow control knob is turned to the "**stop**" position and the electrical supply is isolated. If applicable remove the appropriate circuit fuse.

Caution! Do not over-tighten the hose connector.

- 1.2. Connect the flexible hose from the shower fitting to the outlet of the appliance. Ensure the hose washer is fitted.
- 1.3. Turn the water supplies fully on at the isolating valves. Check that water is not leaking from the bottom of the case.
- 1.4. Switch on the electrical supply to the product.
- 1.5. Turn the flow control knob anticlockwise fully to start the shower. Check that water flows freely from the shower within a few seconds.
- 1.6. Turn the flow control knob fully anticlockwise to select the maximum flow.
- 1.7. Turn the temperature knob anticlockwise to check the hot supply and clockwise to check the cold supply.
- 1.8. Turn the flow control knob clockwise to the "**stop**" position to switch off the shower and stop the flow of water.

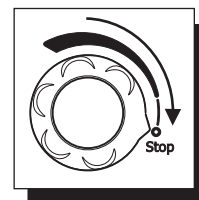
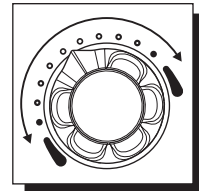
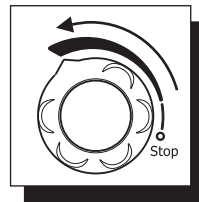
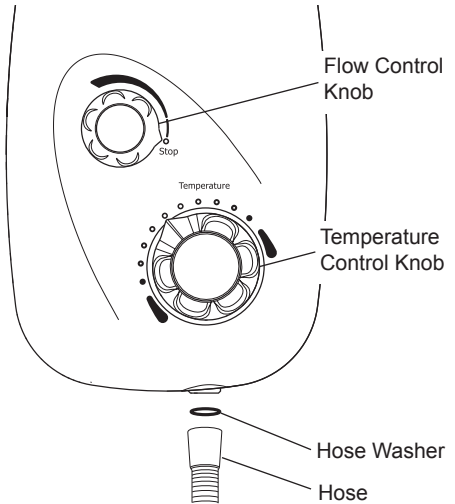

OPERATION

Warning! The shower is a manual mixing shower which can select water temperatures from **FULL HOT** to **FULL COLD**. If the temperature control knob is turned anticlockwise fully the shower will deliver water at the same temperature as the stored hot water temperature (this will be the same temperature as the hot tap water temperature).

Note! The shower is a manual mixing shower. The showering temperature will change if the incoming water temperature changes. Therefore incoming water supply temperatures must remain constant if a stable showering temperature is to be achieved.

- 1.1. From the "**stop**" position turn the flow control knob anticlockwise to start the flow of water.
- 1.2. Turn the flow control knob until the desired flow of water is obtained. The further the flow knob is turned anticlockwise the greater the flow.
- 1.3. Turn the temperature control knob in the direction of the red indicator (anticlockwise) for warmer water and in the direction of the blue indicator (clockwise) for cooler water, until the desired water temperature is achieved.
- 1.4. Turn the flow control knob clockwise to the "**stop**" position to stop the flow of water.

Note! If the Mira Event XS is used continuously for a prolonged period the self-resetting thermal trip fitted may operate. This will shutdown the pump motor and prevent it from overheating.

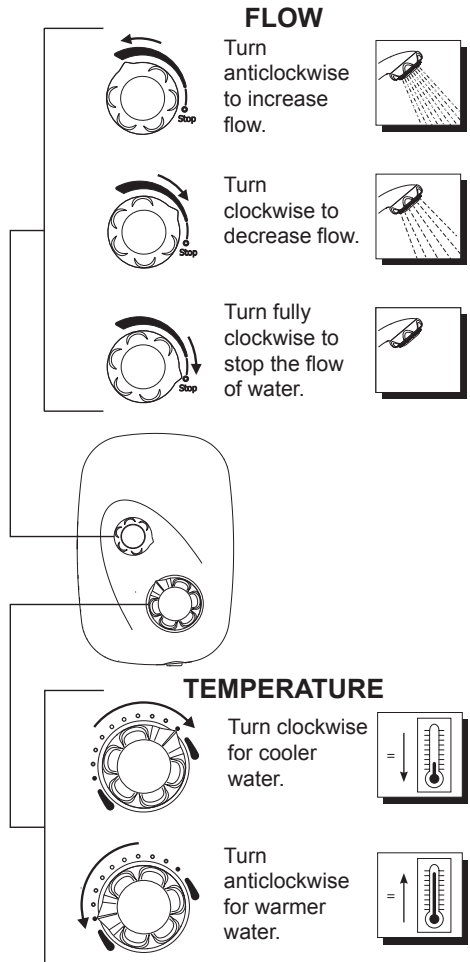

FAULT DIAGNOSIS

1. User Maintenance

The Mira Event XS is fully performance tested after assembly. Providing the Mira Event XS has been correctly installed and is operated as advised, difficulties should not arise. In the unlikely event that you experience problems with your appliance then the following procedure will enable you to undertake basic fault finding before contacting the person responsible for installing your shower.

Malfunction	Cause	Remedy
Shower temperature too cold.	Hot water cylinder temperature less than 12°C above shower temperature.	Adjust cylinder temperature. Note! It is recommended that the stored water temperature does not exceed 65°C .
Blend temperature unstable.	Spray plate blocked. Inlet filter blocked. Isolating valve partially closed. Plumbing system fault.	Clean spray plate. Refer to the Installation & User guide supplied with the shower fittings. Contact your installer. Open valve. Contact your installer.
Pump does not operate.	Electrical supply failure. PCB failure. Motor overheated, thermal switch operated.	Contact your installer. Contact your installer. If the thermal switch operates repeatedly contact customer services for further advice.
Low or no water flow.	Isolating valves closed. Inlet filters blocked. Check valve fitted incorrectly. Appliance sited above cold water storage cistern. Plumbing system fault (airlock).	Open valves. Contact your installer. Contact your installer. The appliance is not suitable for negative head installations. Refer to section: ' Installation Requirements '. Contact your installer.

2. Installer Maintenance

The Mira Event XS is one part of an entire plumbing system. The fitting of a pump places additional requirements on the plumbing system. Some systems may require plumbing modifications to allow them to cope with higher flow rates.

Providing the Mira Event XS has been correctly installed and is operated as advised, difficulties should not arise. Fault diagnosis and maintenance must be carried out by a competent person for whom the fault diagnosis table is provided.

In the event of any of the following tests failing, re-check as appropriate before contacting the Kohler Mira Ltd (our contact details can be found on the back cover of this guide).

Malfunction	Cause	Remedy
Shower runs for a short time (30-60 seconds) then flow reduces, splutters or stops. Aggravated when other hot taps are in use. Less evident on full cold.	Air is being sucked down the vent pipe, as the hot take off to the shower is too high up the pipe.	Refer to plumbing system diagrams in section: 'Installation Requirements' . Note the 1 metre hot take-off dimension. Consider increasing cold feed pipe to cylinder to 28 mm diameter.
Shower runs cool after a short time (1–2 minutes) then flow splutters.	Air ingress into hot pipework.	Refer to plumbing system diagrams in section: 'Installation Requirements' .
Flow of water virtually stops and surges on/off, after a few minutes.	Insufficient storage of cold water in cistern (230 litres recommended).	Increase storage of cold water cistern.
Shower runs cold after 5–10 minutes.	Insufficient storage of hot water in cylinder.	Increase storage of hot water.
Shower temperature affected by use of adjacent hot/cold tap.	Insufficiently sized pipework for both systems to be used together.	Increase pipe sizes or separately feed shower. Refer to plumbing system diagrams in the section: 'Installation Requirements' .
Shower temperature too cold.	Hot water cylinder temperature less than 12°C above shower temperature.	Adjust cylinder temperature. Note! It is recommended that the stored water temperature does not exceed 65°C .

Blend temperature unstable.	Inlet filter blocked. Isolating valve partially closed. Spray plate blocked.	Clean filters. Open valve. Clean spray plate. Refer to the Installation and User guide supplied with the shower fittings.
Drip from shower head.	Solenoid valve defective.	Renew the solenoid assembly.
Pump does not operate.	Electrical supply failure. PCB failure. Motor overheated, thermal switch operated.	Check power supply. Renew the PCB. If the thermal switch operates repeatedly contact Kohler Mira for further advice.
Pump speed does not change.	PCB failure.	Renew the PCB.
Low or no water flow.	Isolating valves closed. Inlet filters blocked. Check valve fitted incorrectly. Appliance sited above cold water storage cistern. Plumbing system fault (airlock). Blocked spray plate.	Open valves. Clean filters, refer to section: 'Maintenance' . Check, refer to section: 'Maintenance' . The appliance is not suitable for negative head installations, refer to section: 'Installation Requirements' . Reroute the pipework to avoid airlock. Clean spray plate. Refer to the Installation and User guide supplied with the shower fittings.
Pump does not stop.	Microswitch failure. PCB failure.	Renew the harness assembly. Renew the PCB.

MAINTENANCE

1. General

Read the section '**Important Safety Information**' first.

If any maintenance is required then it must be carried out by a competent tradesperson for whom the maintenance instructions are provided. Before replacing any parts ensure that the underlying cause of the malfunction has been resolved.

Warning! There are no user serviceable components beneath the cover of the appliance. Only a competent tradesperson should remove the cover.

2. Cleaning

Many household cleaners contain abrasives and chemical substances, and should not be used for cleaning plated or plastic fittings. These finishes should be cleaned with a mild washing up detergent or soap solution, and then wiped dry using a soft cloth.

3. Front Cover – Removal

Warning! Before proceeding turn off the electrical and water supplies. The electricity supply must be turned off at the mains and, if applicable, the appropriate circuit fuse removed. Mains electrical connections are exposed when the cover is removed.

3.1. Remove the temperature knob concealing cap.

3.2. Insert the end of the push-fit tool under the temperature control knob, inline with the temperature indicator, and lever off the temperature knob.

3.3. Unscrew the three cover retaining screws sufficiently to remove the cover.

Note! The cover retaining screws are captive and need not be removed.

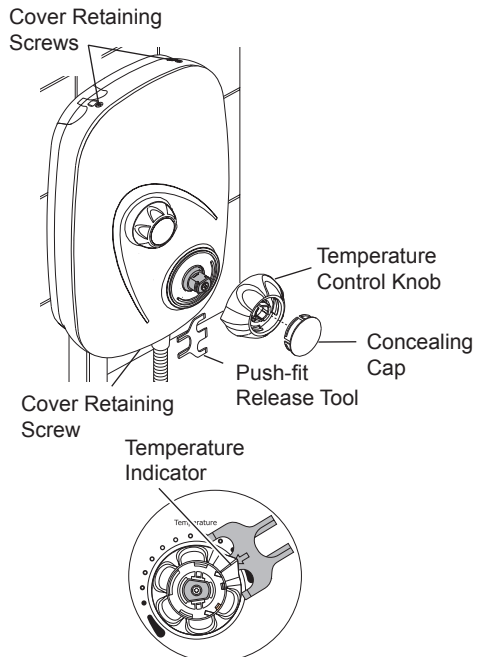

4. Inlet Filter Cap, Cleaning – Removal and Installation

The following procedure can be applied for cleaning or renewing the inlet filter cap or inlet filter cap 'O' seals.

Warning! Before proceeding, turn off the electrical and water supplies. The electricity supply must be turned off at the mains and, if applicable, the appropriate circuit fuse removed. Mains electrical connections are exposed when the cover is removed.

4.1. Remove the front cover, refer to section: '**Maintenance, 3. Front Cover – Removal**'.

4.2. Unscrew the retaining screw and remove the filter cap.

Note! A small amount of trapped water may drain from the manifold.

4.3. Thoroughly clean both the inlet filter meshes. Inspect the 'O' seals and renew if required. Before refitting the inlet filter cap lightly grease 'O' seals with a silicone based lubricant.

4.4. Refit components in reverse order.

4.5. Restore the water supplies and check for any leaks.

4.6. Refit the cover and secure with the three cover retaining screws, refit the temperature knob and concealing cap.

4.7. Restore the electrical supply.

4.8. Commission the Mira Event XS, refer to section: '**Commissioning**'.

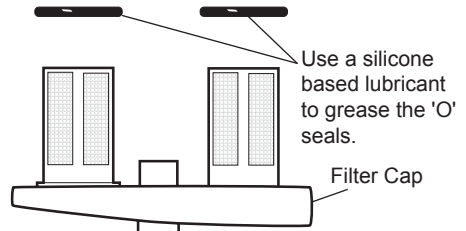
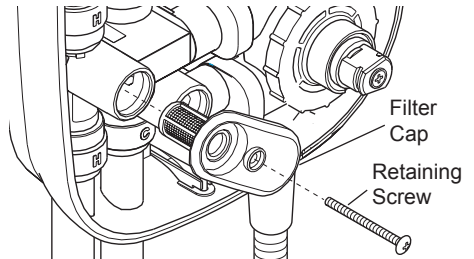

5. Inlet Manifold, Check Valve - Removal and Installation

The following procedure can be applied to cleaning or renewing the inlet manifold, inlet check valves or 'O' seals.

Warning! Before proceeding turn off the electrical and water supplies. The electricity supply must be turned off at the mains and, if applicable, the appropriate circuit fuse removed. Mains electrical connections are exposed when the cover is removed.

5.1. Remove the front cover, refer to section: '**Maintenance, 3. Front Cover – Removal**'.

5.2. Disconnect the electrical supply cable from the terminal block.

5.3. Remove the flexible hose from the appliance.

5.4. Remove the three wall fixing screws.

5.5. Using the push-fit release tool, push back and hold the collets from the supply pipework, lift the Mira Event XS from the wall to remove the supply pipework from the inlet manifold.

5.6. Remove the screws securing the inlet manifold and mixer assembly using a T10 Torx screwdriver. Unclip the pump transfer tube.

5.7. Remove the inlet manifold and mixer assembly.

5.8. The ports adjacent to the mixer assembly contain the inlet check valves. The check valves can be removed and replaced if required. Ensure the check valve is inserted with the 'O' seal on the check valve facing into the outlet port of the manifold.

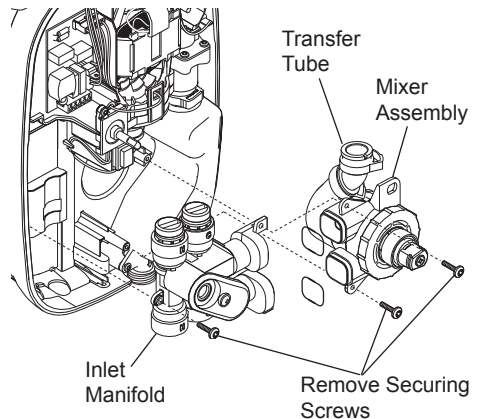
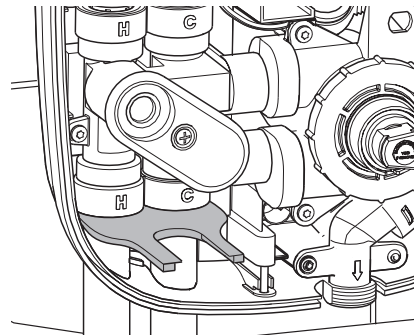
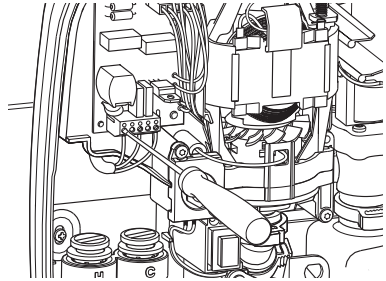

5.9. Inspect inlet manifold/valve interface seals and renew if required.

Note! When refitting the inlet manifold, lightly grease seals with a silicone based lubricant.

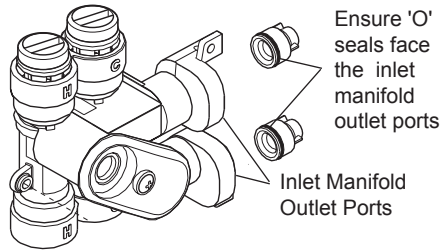

5.10. Refit components in reverse order.

5.11. Restore the water supplies and check for any leaks.

5.12. Refit the cover and secure by tightening the three cover retaining screws, refit the temperature control knob and concealing cap.

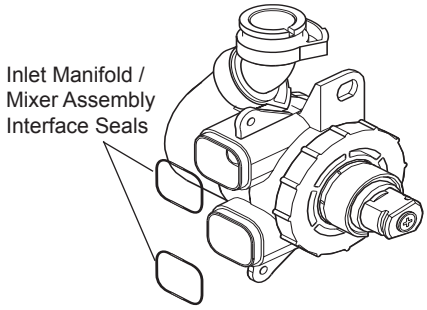

5.13. Commission the Mira Event XS, refer to section: '**Commissioning**'.

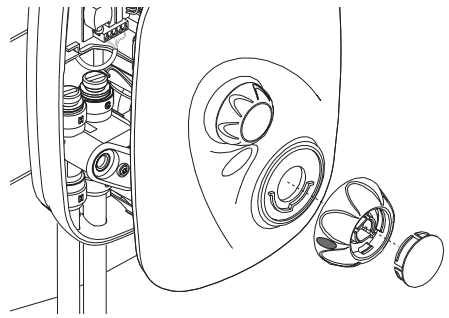

WIRING DIAGRAM

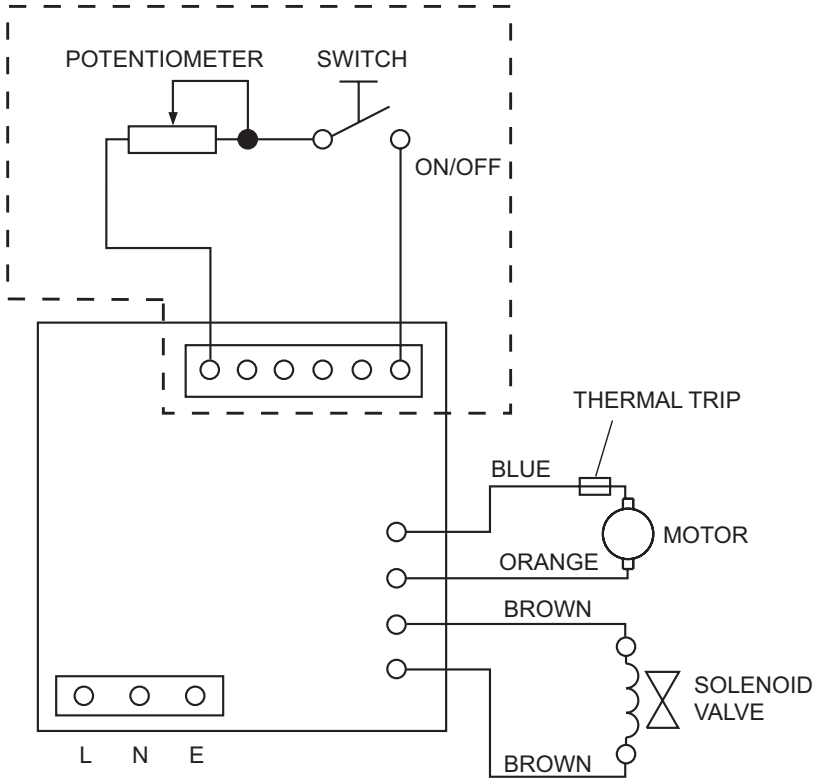

SPARE PARTS

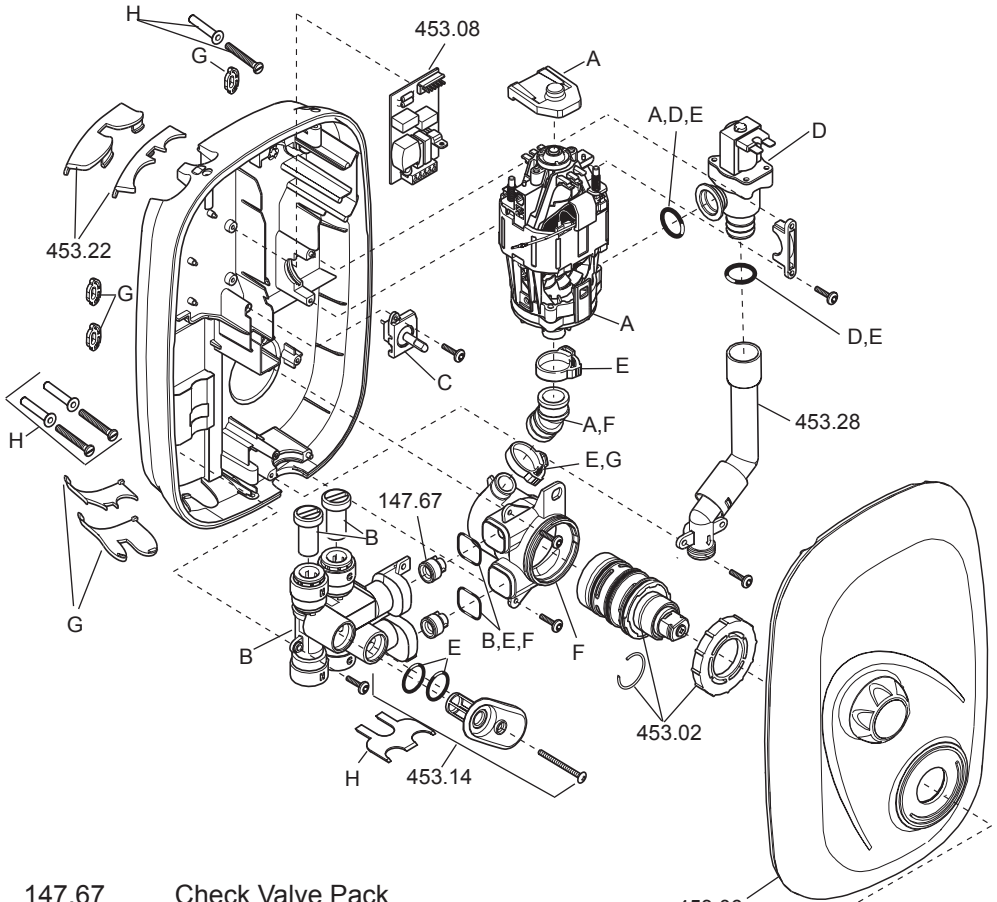

- 147.67 Check Valve Pack
- 453.02 Cartridge - Manual
- 453.03 Motor Pump Assembly - identified 'A'
- 453.06 Cover Assembly - Manual
- 453.07 Inlet Manifold Assembly - identified 'B'
- 453.08 PCB Assembly - Power
- 453.11 Harness Assembly - Manual - identified 'C'
- 453.13 Solenoid Valve Assembly - identified 'D'
- 453.14 Filter/Cap Assembly
- 453.15 Seal Pack - identified 'E'
- 453.18 Temperature Knob Assembly - Manual
- 453.23 Mixer Valve Body- identified 'F'
- 453.24 Inserts/Rubber Feet Pack - Power - identified 'G'
- 453.28 Outlet Elbow Assembly
- 1532.297 Stud Wall Fixing Kit – identified 'H'

ACCESSORIES

Genuine Mira accessories can be purchased direct from Customers Services (our contact details can be found on the back cover of this guide) or from approved stockists or merchants.

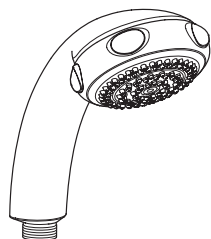

Eco Showerhead
White - 2.1668.001
Chrome - 2.1668.002

The Eco shower head gives you an invigorating shower, but reduces water consumption and heating costs.

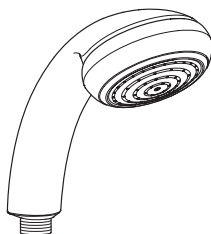

Everclear Showerhead
White - 2.1616.030
Chrome - 2.1616.031

Mira's new Everclear range has been specially designed for hard water areas and reduces the risk of lime scale build up.

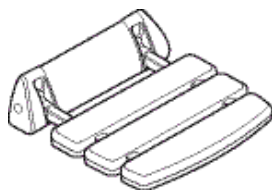

Shower Seat
White - 2.1536.128
White/Chrome - 2.1536.129

For use in or out of the showering area. **Note!** Must be installed onto a solid wall. Shower seat folds up when not in use

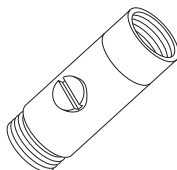

Double Outlet Check Valve (DCV-H)
Chrome - 1.0.110.55.1

DCV-H: An outlet double check valve, designed to prevent the backflow or backsiphonage of potentially contaminated water, through shower controls which are fitted with a flexible hose as part of the outlet shower fitting.

NOTES

NOTES

NOTES

CUSTOMER SERVICES

Guarantee

Your product has the benefit of our manufacturer's guarantee which starts from the date of purchase.

To activate this guarantee, please return your completed registration card, visit our website or free phone 0800 0731248 within 30 days of purchase (UK only).

Within the guarantee period we will resolve defects in materials or workmanship, free of charge, by repairing or replacing parts or product as we may choose.

This guarantee is in addition to your statutory rights and is subject to the following conditions:

- The product must be installed and maintained in accordance with the instructions given in this user guide.
- Servicing must only be undertaken by us or our appointed representative. **Note!** if a service visit is required the product must be fully installed and connected to services.
- Repair under this guarantee does not extend the original expiry date. The guarantee on any replacement parts or product ends at the original expiry date.
- For shower fittings or consumable items we reserve the right to supply replacement parts only.

The guarantee does not cover:

- Call out charges for non product faults (such as damage or performance issues arising from incorrect installation, improper use, lack of maintenance, build up of limescale, frost damage, corrosion, system debris or blocked filters) or where no fault has been found with the product.
- Water or electrical supply, waste and isolation issues.
- Compensation for loss of use of the product or consequential loss of any kind.
- Damage or defects caused if the product is repaired or modified by persons not authorised by us or our appointed representative.
- Routine maintenance or replacement parts to comply with the requirements of the TMV 2 or TMV 3 healthcare schemes.

What to do if something goes wrong

If your product does not function correctly when you first use it, contact your installer to check that it is installed and commissioned in accordance with the instructions in this manual.

Should this not resolve the issue, contact our Customer Services Team who will offer you or your installer advice and if applicable arrange for a Service Technician to call.

If the performance of your product declines, check in this manual to see if simple home maintenance is required. If you require further assistance call our Customer Services Team.

Extended Guarantees

A selection of protection plans are available that enable you to cover repair bills for the life of your policy (excludes Eire). Ring 01922 471763 for more details.

Helpdesk Service

Our dedicated Customer Services Team is comprehensively trained and can offer help and advice, spare parts, accessories or a service visit. We will need you to have your model name or number, power rating (if applicable) and date of purchase. As part of our quality and training programme calls may be recorded or monitored.

Mira Showers Website (www.mirashowers.co.uk)

From our website you can register your guarantee, download additional user guides, diagnose faults, purchase our full range of accessories and popular spares, refer to our FAQ's and request a service visit.

Spares and Accessories

We maintain extensive stocks of genuine spares and accessories and aim to provide support throughout the product's expected life. Payment can be made by phone at time of order using most major Credit or Debit cards and we aim to despatch orders within two working days. Items purchased from us are guaranteed for 12 months from date of purchase. For safety reasons spares exposed to mains voltages should only be fitted by competent persons.

Returns – items can be returned within one month of date of purchase, providing that they are in good condition and the packaging is unopened. Please obtain authorisation from our Customer Services Team before return. We reserve the right to apply a 15% restocking charge.

Service / Repairs

We have a nationwide team of Service Technicians who can carry out all service or repair work to your product within the guarantee period and beyond. You have the assurance of a fully trained Mira Technician, genuine Mira spare parts and a 12 month guarantee on any chargeable work done.

Payment should be made directly to the Service Technician who will accept most major Credit or Debit cards.

To Contact Us

UK

Telephone: 0844 571 5000

Mon to Fri 8:00 am - 5:30 pm, Sat 8:30 am - 3:30 pm

E-mail: technical@mirashowers.com

Fax: 01242 282595

By Post: Mira Customer Services Dept, Cromwell Road, Cheltenham, Gloucestershire, GL52 5EP

Eire

Telephone: 01 459 1344

Mon to Fri 9:00 am - 5:00 pm

E-mail: sales@modernplant.ie

Fax: Dublin 01 459 2329

By Post: Modern Plant Ltd (Dublin), Otter House, Naas Road, Clondalkin, Dublin 22

Mira is a registered trade mark of
Kohler Mira Limited.

The company reserves the right to alter
product specifications without notice.



FM 14648

mira
SHOWERS