

Robert Bosch GmbH

Power Tools Division
70745 Leinfelden-Echterdingen
Germany

www.bosch-pt.com

1 609 92A 0CN (2013.07) T / 157 EURO



1 609 92A 0CN

GSA 1300 PCE Professional



de Originalbetriebsanleitung
en Original instructions
fr Notice originale
es Manual original
pt Manual original
it Istruzioni originali
nl Oorspronkelijke gebruikers-
aanwijzing
da Original brugsanvisning
sv Bruksanvisning i original
no Original driftsinstruks
fi Alkuperäiset ohjeet
el Πρωτότυπο οδηγιών χρήσης

tr Orijinal işletme talimatı
pl Instrukcja oryginalna
cs Původní návod k používání
sk Pôvodný návod na použitie
hu Eredeti használati utasítás
ru Оригинальное руководство
по эксплуатации
uk Оригінальна інструкція з
експлуатації
kk Пайдалану нұсқаулығының
түпнұсқасы
ro Instrucțiuni originale
bg Оригинална инструкция

mk Оригинално упатство за работа
sr Originalno uputstvo za rad
sl Izvirna navodila
hr Originalne upute za rad
et Algupärane kasutusjuhend
lv Instrukcijas oriģinālvalodā
lt Originali instrukcija
ar تعليمات التشغيل الأصلية
fa دفترچه راهنمای اصلی



3 |

The diagram illustrates six different types of Bosch saw blades, each with a corresponding application icon:

- WOOD**: A standard wood-cutting blade.
- HCS** High carbon steel: Shown with a wood grain icon, indicating use for wood.
- BIM** Bi-Metal: Shown with a metal icon, indicating use for metal.
- BIM** Bi-Metal: Shown with a metal icon, indicating use for metal.
- BIM** Bi-Metal: Shown with a metal icon and a **DEMOLITION** icon, indicating use for metal and demolition.
- BIM** Bi-Metal: Shown with a metal icon, a wood grain icon, and a **FIBREGLASS** icon, indicating use for metal, wood, and fiberglass.

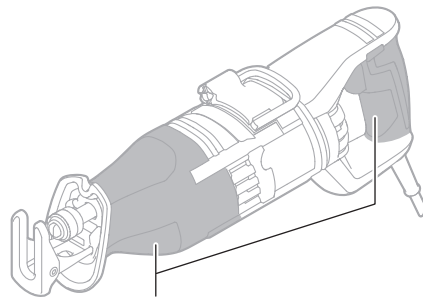
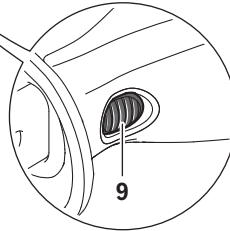
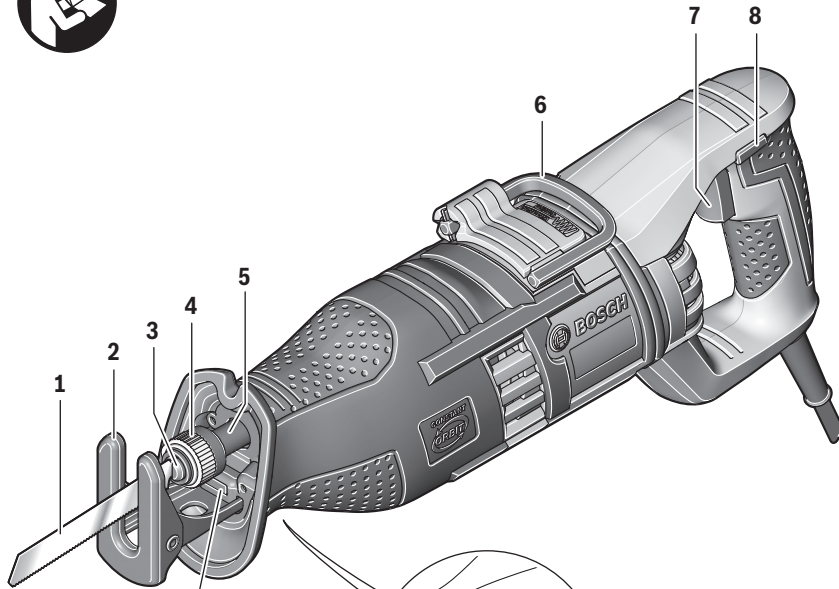

GSA 1300 PCE



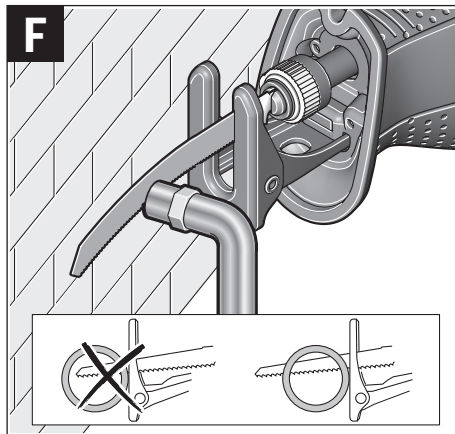
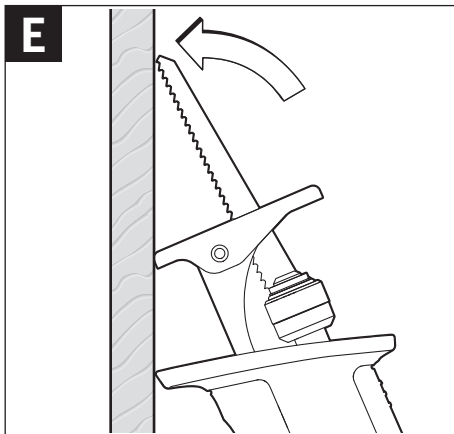
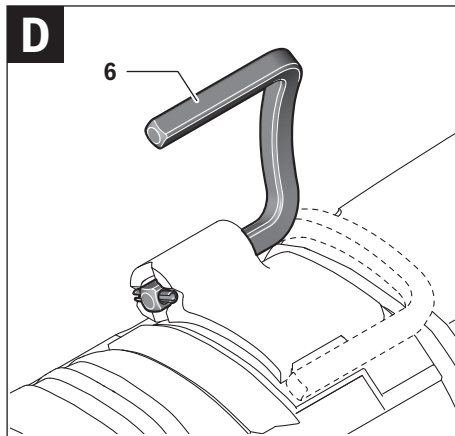
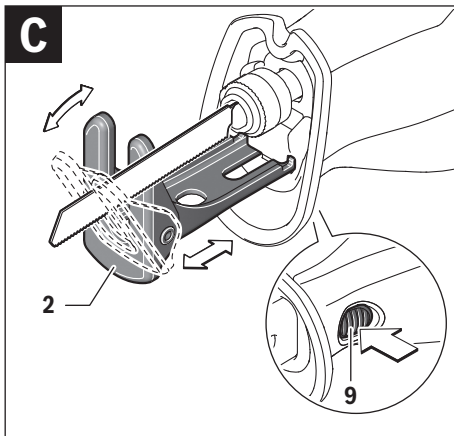
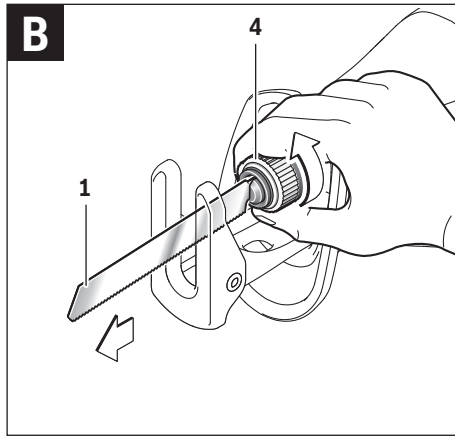
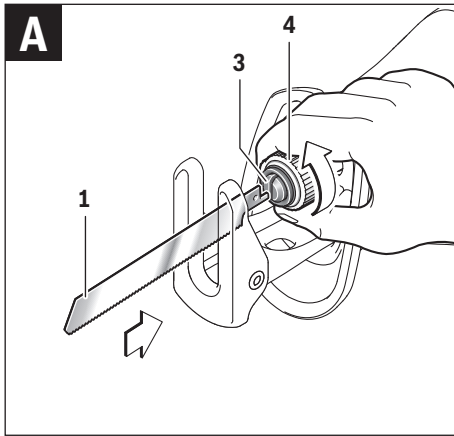

English

Safety Notes

General Power Tool Safety Warnings

⚠ WARNING Read all safety warnings and all instructions. Failure to follow the warnings and instructions may result in electric shock, fire and/or serious injury.

Save all warnings and instructions for future reference.

The term "power tool" in the warnings refers to your mains-operated (corded) power tool or battery-operated (cordless) power tool.

Work area safety

- ▶ **Keep work area clean and well lit.** Cluttered or dark areas invite accidents.
- ▶ **Do not operate power tools in explosive atmospheres, such as in the presence of flammable liquids, gases or dust.** Power tools create sparks which may ignite the dust or fumes.
- ▶ **Keep children and bystanders away while operating a power tool.** Distractions can cause you to lose control.

Electrical safety

- ▶ **Power tool plugs must match the outlet. Never modify the plug in any way. Do not use any adapter plugs with earthed (grounded) power tools.** Unmodified plugs and matching outlets will reduce risk of electric shock.
- ▶ **Avoid body contact with earthed or grounded surfaces, such as pipes, radiators, ranges and refrigerators.** There is an increased risk of electric shock if your body is earthed or grounded.
- ▶ **Do not expose power tools to rain or wet conditions.** Water entering a power tool will increase the risk of electric shock.
- ▶ **Do not abuse the cord. Never use the cord for carrying, pulling or unplugging the power tool. Keep cord away from heat, oil, sharp edges and moving parts.** Damaged or entangled cords increase the risk of electric shock.
- ▶ **When operating a power tool outdoors, use an extension cord suitable for outdoor use.** Use of a cord suitable for outdoor use reduces the risk of electric shock.
- ▶ **If operating a power tool in a damp location is unavoidable, use a residual current device (RCD) protected supply.** Use of an RCD reduces the risk of electric shock.

Personal safety

- ▶ **Stay alert, watch what you are doing and use common sense when operating a power tool. Do not use a power tool while you are tired or under the influence of drugs, alcohol or medication.** A moment of inattention while operating power tools may result in serious personal injury.
- ▶ **Use personal protective equipment. Always wear eye protection.** Protective equipment such as dust mask, non-skid safety shoes, hard hat, or hearing protection used for appropriate conditions will reduce personal injuries.

- ▶ **Prevent unintentional starting. Ensure the switch is in the off-position before connecting to power source and/or battery pack, picking up or carrying the tool.** Carrying power tools with your finger on the switch or energising power tools that have the switch on invites accidents.
- ▶ **Remove any adjusting key or wrench before turning the power tool on.** A wrench or a key left attached to a rotating part of the power tool may result in personal injury.
- ▶ **Do not overreach. Keep proper footing and balance at all times.** This enables better control of the power tool in unexpected situations.
- ▶ **Dress properly. Do not wear loose clothing or jewellery. Keep your hair, clothing and gloves away from moving parts.** Loose clothes, jewellery or long hair can be caught in moving parts.
- ▶ **If devices are provided for the connection of dust extraction and collection facilities, ensure these are connected and properly used.** Use of dust collection can reduce dust-related hazards.

Power tool use and care

- ▶ **Do not force the power tool. Use the correct power tool for your application.** The correct power tool will do the job better and safer at the rate for which it was designed.
- ▶ **Do not use the power tool if the switch does not turn it on and off.** Any power tool that cannot be controlled with the switch is dangerous and must be repaired.
- ▶ **Disconnect the plug from the power source and/or the battery pack from the power tool before making any adjustments, changing accessories, or storing power tools.** Such preventive safety measures reduce the risk of starting the power tool accidentally.
- ▶ **Store idle power tools out of the reach of children and do not allow persons unfamiliar with the power tool or these instructions to operate the power tool.** Power tools are dangerous in the hands of untrained users.
- ▶ **Maintain power tools. Check for misalignment or binding of moving parts, breakage of parts and any other condition that may affect the power tool's operation. If damaged, have the power tool repaired before use.** Many accidents are caused by poorly maintained power tools.
- ▶ **Keep cutting tools sharp and clean.** Properly maintained cutting tools with sharp cutting edges are less likely to bind and are easier to control.
- ▶ **Use the power tool, accessories and tool bits etc. in accordance with these instructions, taking into account the working conditions and the work to be performed.** Use of the power tool for operations different from those intended could result in a hazardous situation.

Service

- ▶ **Have your power tool serviced by a qualified repair person using only identical replacement parts.** This will ensure that the safety of the power tool is maintained.

12 | English

Safety Warnings for Sabre Saws

- ▶ **Hold power tool by insulated gripping surfaces, when performing an operation where the cutting accessory may contact hidden wiring or its own cord.** Cutting accessory contacting a "live" wire may make exposed metal parts of the power tool "live" and could give the operator an electric shock.
- ▶ **Keep hands away from the sawing range. Do not reach under the workpiece.** Contact with the saw blade can lead to injuries.
- ▶ **Apply the machine to the workpiece only when switched on.** Otherwise there is danger of kickback when the cutting tool jams in the workpiece.
- ▶ **When sawing, the adjustable footplate 2 must always faces against the workpiece.** The saw blade can become wedged and lead to loss of control over the machine.
- ▶ **When the cut is completed, switch off the machine and then pull the saw blade out of the cut only after it has come to a standstill.** In this manner you can avoid kickback and can place down the machine securely.
- ▶ **Use only undamaged saw blades that are in perfect condition.** Bent or dull saw blades can break, negatively influence the cut, or lead to kickback.
- ▶ **Do not brake the saw blade to a stop by applying side pressure after switching off.** The saw blade can be damaged, break or cause kickback.
- ▶ **Clamp material well. Do not support the workpiece with your hand or foot. Do not touch objects or the floor with the saw running.** Danger of kickback.
- ▶ **Use suitable detectors to determine if utility lines are hidden in the work area or call the local utility company for assistance.** Contact with electric lines can lead to fire and electric shock. Damaging a gas line can lead to explosion. Penetrating a water line causes property damage or may cause an electric shock.
- ▶ **When working with the machine, always hold it firmly with both hands and provide for a secure stance.** The power tool is guided more secure with both hands.
- ▶ **Secure the workpiece.** A workpiece clamped with clamping devices or in a vice is held more secure than by hand.
- ▶ **Always wait until the machine has come to a complete stop before placing it down.** The tool insert can jam and lead to loss of control over the power tool.
- ▶ **Products sold in GB only:** Your product is fitted with an BS 1363/A approved electric plug with internal fuse (ASTA approved to BS 1362).
If the plug is not suitable for your socket outlets, it should be cut off and an appropriate plug fitted in its place by an authorised customer service agent. The replacement plug should have the same fuse rating as the original plug. The severed plug must be disposed of to avoid a possible shock hazard and should never be inserted into a mains socket elsewhere.
- ▶ **Products sold in AUS and NZ only:** Use a residual current device (RCD) with a rated residual current of 30 mA or less.

Product Description and Specifications

Read all safety warnings and all instructions. Failure to follow the warnings and instructions may result in electric shock, fire and/or serious injury.

While reading the operating instructions, unfold the graphics page for the machine and leave it open.

Intended Use

The machine is intended for sawing wood, plastic, metal and building materials while resting firmly on the workpiece. It is suitable for straight and curved cuts. When using the appropriate bimetal saw blades, it is possible to cut flush to the workpiece surface. The saw blade recommendations must be observed.

The light of this power tool is intended to illuminate the power tool's direct area of working operation and is not suitable for household room illumination.

Product Features

The numbering of the product features refers to the illustration of the machine on the graphics page.

- 1 Saw blade*
- 2 Adjustable footplate
- 3 Saw blade holder
- 4 Locking sleeve for saw blade
- 5 Stroke rod
- 6 Utility hook
- 7 On/Off switch
- 8 Lock-off button for On/Off switch
- 9 Footplate release button
- 10 "PowerLight"
- 11 Handle (insulated gripping surface)

*Accessories shown or described are not part of the standard delivery scope of the product. A complete overview of accessories can be found in our accessories program.

Technical Data

Sabre saw	GSA 1300 PCE	
Article number		3 601 F4E 2..
Rated power input	W	1300
Stroke rate at no load n_0	min ⁻¹	0 – 2900
Tool holder		SDS
Orbital action		●
Constant electronic control		●
Stroke	mm	28
Cutting depth, max.		
– in wood	mm	220
– in non-alloy steel	mm	20
– Pipe diameter	mm	175
Weight according to EPTA-Procedure 01/2003	kg	4.1
Protection class		□/II

The values given are valid for a nominal voltage [U] of 230 V. For different voltages and models for specific countries, these values can vary.

Noise/Vibration Information

Measured sound values determined according to EN 60745. Typically the A-weighted noise levels of the product are: Sound pressure level 95 dB(A); Sound power level 106 dB(A). Uncertainty K = 3 dB.

Wear hearing protection!

Vibration total values a_h (triax vector sum) and uncertainty K determined according to EN 60745:

Cutting board: $a_h = 17.5 \text{ m/s}^2$, $K = 1.5 \text{ m/s}^2$,

Cutting wooden beam: $a_h = 23.5 \text{ m/s}^2$, $K = 1.5 \text{ m/s}^2$.

The vibration emission level given in this information sheet has been measured in accordance with a standardised test given in EN 60745 and may be used to compare one tool with another. It may be used for a preliminary assessment of exposure.

The declared vibration emission level represents the main applications of the tool. However if the tool is used for different applications, with different accessories or poorly maintained, the vibration emission may differ. This may significantly increase the exposure level over the total working period.



An estimation of the level of exposure to vibration should also take into account the times when the tool is switched off or when it is running but not actually doing the job. This may significantly reduce the exposure level over the total working period. Identify additional safety measures to protect the operator from the effects of vibration such as: maintain the tool and the accessories, keep hands warm, organise work patterns.

Declaration of Conformity

We declare under our sole responsibility that the product described under "Technical Data" is in conformity with the following standards or standardisation documents: EN 60745 according to the provisions of the directives 2009/125/EC (Regulation 1194/2012), 2011/65/EU, 2004/108/EC, 2006/42/EC.

Technical file (2006/42/EC) at:
Robert Bosch GmbH, PT/ETM9,
D-70745 Leinfelden-Echterdingen

Henk Becker	Helmut Heinzelmann
Executive Vice President	Head of Product Certification
Engineering	PT/ETM9

PPA.
 i.V. 

Robert Bosch GmbH, Power Tools Division
D-70745 Leinfelden-Echterdingen
Leinfelden, 08.07.2013

Assembly

Replacing/Inserting the Saw Blade

- ▶ **Before any work on the machine itself, pull the mains plug.**
- ▶ **When mounting the saw blade, wear protective gloves.**
Danger of injury when touching the saw blade.
- ▶ **When changing the saw blade, take care that the saw blade holder is free of material residue, e. g. wood or metal shavings.**

Selecting a Saw Blade

An overview of recommended saw blades can be found at the beginning of these instructions. Use only ½" universal shank saw blades. The saw blade should not be longer than required for the intended cut.

Use a thin saw blade for narrow curve cuts.

Inserting the Saw Blade (see figure A)

Turn the locking sleeve **4** approx. 90° in the direction of the arrow and hold. Push the saw blade **1** into the saw blade holder **3**. Release the locking sleeve **4** again.

- ▶ **Check the tight seating of the saw blade.** A loose saw blade can fall out and lead to injuries.

For certain work, the saw blade **1** can also be turned through 180° (with the teeth pointed upwards) and re-inserted again.

Removing the Saw Blade (see figure B)

- ▶ **Before removing, allow the saw blade to cool down.**
Danger of injury when touching the hot saw blade.

Turn the locking sleeve **4** approx. 90° in the direction of the arrow and hold. Remove the saw blade **1**.

Dust/Chip Extraction

- ▶ Dusts from materials such as lead-containing coatings, some wood types, minerals and metal can be harmful to one's health. Touching or breathing-in the dusts can cause allergic reactions and/or lead to respiratory infections of the user or bystanders.

Certain dusts, such as oak or beech dust, are considered as carcinogenic, especially in connection with wood-treatment additives (chromate, wood preservative). Materials containing asbestos may only be worked by specialists.

- Provide for good ventilation of the working place.
- It is recommended to wear a P2 filter-class respirator.

Observe the relevant regulations in your country for the materials to be worked.

- ▶ **Prevent dust accumulation at the workplace.** Dusts can easily ignite.

Operation

Operating Modes

- ▶ **Before any work on the machine itself, pull the mains plug.**

Pivoting and Retractable Footplate (see figure C)

Due to its movability, the adjustable footplate **2** adapts to the required angular position of the surface.

Depending on the saw blade being used and the application, the footplate **2** can be moved in lengthway direction in three steps. Press the release button for the footplate **9** and slide the footplate **2** to the required position. Release the footplate release button **9** and check that the footplate **2** is firmly latched. Slide the footplate **2** as required until it is firmly latched.

14 | English

Utility Hook (see figure D)

Your tool is equipped with a utility hook **6** for hanging it, e.g., to a ladder, etc. Simply fold out the utility hook **6** to the required position.

- ▶ **When the tool is hanging by the utility hook, ensure that the saw blade is protected against unintended contact. Danger of injury.**

Fold the utility hook **6** back in again when you are ready to continue working.

Starting Operation

- ▶ **Observe correct mains voltage! The voltage of the power source must agree with the voltage specified on the nameplate of the machine. Power tools marked with 230 V can also be operated with 220 V.**

The "PowerLight" **10** is lit when the mains plug is inserted, and allows for illumination of the working range under unfavourable light conditions.

Switching On and Off

To **start** the machine, **first** push the lock-off button for the On/Off switch **8** and **then** press the On/Off switch **7** and keep it pressed.

To **switch off** the machine, release the On/Off switch **7**.

Note: For safety reasons, the On/Off switch **7** cannot be locked; it must remain pressed during the entire operation.

To save energy, only switch the power tool on when using it.

Orbital action

To achieve a high cutting speed, the orbital action is continuously in operation.

Constant Electronic Control

The constant electronic control keeps the stroke rate almost constant at no-load and under load, and ensures uniform working performance.

Controlling/Presetting the Stroke Rate

Increasing or reducing the pressure on the On/Off switch **7** enables stepless stroke-rate control of the switched-on machine.

Light pressure on the On/Off switch **7** results in a low stroke rate. Increasing the pressure also increases the stroke rate.

The required stroke rate is dependent on the material and the working conditions and can be determined by a practical trial.

Reducing the stroke rate is recommended when the saw blade engages in the material as well as when sawing plastic and aluminium.

Working Advice

- ▶ **Before any work on the machine itself, pull the mains plug.**

Tips

- ▶ **When sawing light building materials, observe the statutory provisions and the recommendations of the material suppliers.**

Check wood, press boards, building materials, etc. for foreign objects such as nails, screws or similar, and always use the correct sawblade.

Switch the machine on and guide it toward the workpiece. Position the footplate **2** onto the surface of the work and saw through the material applying uniform contact pressure and feed. After completing the working procedure, switch the machine off.

If the saw blade should jam, switch the machine off immediately. Widen the gap somewhat with a suitable tool and pull out the machine.

Plunge Cutting (see figure E)

- ▶ **The plunge cutting procedure is only suitable for treating soft materials such as wood, plaster board or similar! Do not work metal materials with the plunge cutting procedure!**

Use only short saw blades for plunge cutting.

Place the machine with the edge of the footplate **2** onto the workpiece and switch on. For power tools with stroke speed control, set the maximum stroke speed. Press the power tool firmly against the workpiece and allow the saw blade to slowly plunge into the workpiece.

As soon as the footplate **2** fully lays on the surface of the workpiece, continue sawing alongside the desired cutting line.

For certain work, the saw blade **1** can also be inserted turned through by 180° and the sabre saw can be guided accordingly in a reversed manner.

Flush Cuts (see figure F)

Using elastic bimetal saw blades, items still attached to a wall (e.g. projecting building elements such as water pipes, etc.) can be sawn off flush at the wall.

- ▶ **Pay attention that the saw blade always extends beyond the diameter of the material being worked. There is danger of kickback.**

Position the saw blade directly against the wall and apply some lateral pressure via the tool until the footplate faces against the wall. Switch the power tool on and saw through the workpiece, applying constant lateral pressure.

Coolant/Lubricant

When sawing metal, coolant/lubricant should be applied alongside cutting line because of the material heating up.

Maintenance and Service**Maintenance and Cleaning**

- ▶ **Before any work on the machine itself, pull the mains plug.**
- ▶ **For safe and proper working, always keep the machine and ventilation slots clean.**

Clean the saw blade holder preferably with compressed air or a soft brush. Remove the saw blade from the power tool for this. Ensure proper operation of the saw blade holder by applying a suitable lubricant.

Heavy contamination of the machine can lead to malfunctions. Therefore, do not saw materials that produce a lot of dust from below or overhead.

If the replacement of the supply cord is necessary, this has to be done by Bosch or an authorized Bosch service agent in order to avoid a safety hazard.

After-sales Service and Application Service

Our after-sales service responds to your questions concerning maintenance and repair of your product as well as spare parts. Exploded views and information on spare parts can also be found under:

www.bosch-pt.com

Bosch's application service team will gladly answer questions concerning our products and their accessories.

In all correspondence and spare parts order, please always include the 10-digit article number given on the type plate of the machine.

Great Britain

Robert Bosch Ltd. (B.S.C.)

P.O. Box 98

Broadwater Park

North Orbital Road

Denham

Uxbridge

UB 9 5HJ

Tel. Service: (0844) 7360109

Fax: (0844) 7360146

E-Mail: boschservicecentre@bosch.com

Ireland

Origo Ltd.

Unit 23 Magna Drive

Magna Business Park

City West

Dublin 24

Tel. Service: (01) 4666700

Fax: (01) 4666888

Australia, New Zealand and Pacific Islands

Robert Bosch Australia Pty. Ltd.

Power Tools

Locked Bag 66

Clayton South VIC 3169

Customer Contact Center

Inside Australia:

Phone: (01300) 307044

Fax: (01300) 307045

Inside New Zealand:

Phone: (0800) 543353

Fax: (0800) 428570

Outside AU and NZ:

Phone: +61 3 95415555

www.bosch.com.au

Republic of South Africa

Customer service

Hotline: (011) 6519600

Gauteng – BSC Service Centre

35 Roper Street, New Centre

Johannesburg

Tel.: (011) 4939375

Fax: (011) 4930126

E-Mail: bsctools@icon.co.za

KZN – BSC Service Centre

Unit E, Almar Centre

143 Crompton Street

Pinetown

Tel.: (031) 7012120

Fax: (031) 7012446

E-Mail: bsc.dur@za.bosch.com

Western Cape – BSC Service Centre

Democracy Way, Prosperity Park

Milnerton

Tel.: (021) 5512577

Fax: (021) 5513223

E-Mail: bsc@zsd.co.za

Bosch Headquarters

Midrand, Gauteng

Tel.: (011) 6519600

Fax: (011) 6519880

E-Mail: rbsa-hq.pts@za.bosch.com

Disposal

The machine, accessories and packaging should be sorted for environmental-friendly recycling.

Do not dispose of power tools into household waste!

Only for EC countries:



According to the European Guideline 2012/19/EU for Waste Electrical and Electronic Equipment and its implementation into national right, power tools that are no longer usable must be collected separately and disposed of in an environmentally correct manner.

Subject to change without notice.

Français

Avertissements de sécurité

Avertissements de sécurité généraux pour l'outil

⚠ AVERTISSEMENT Lire tous les avertissements de sécurité et toutes les instructions.

Ne pas suivre les avertissements et instructions peut donner lieu à un choc électrique, un incendie et/ou une blessure sérieuse.

Conservation de tous les avertissements et toutes les instructions pour pouvoir s'y reporter ultérieurement.

Le terme « outil » dans les avertissements fait référence à votre outil électrique alimenté par le secteur (avec cordon d'alimentation) ou votre outil fonctionnant sur batterie (sans cordon d'alimentation).