

Mira Elite QT 9.8kW / 10.8kW

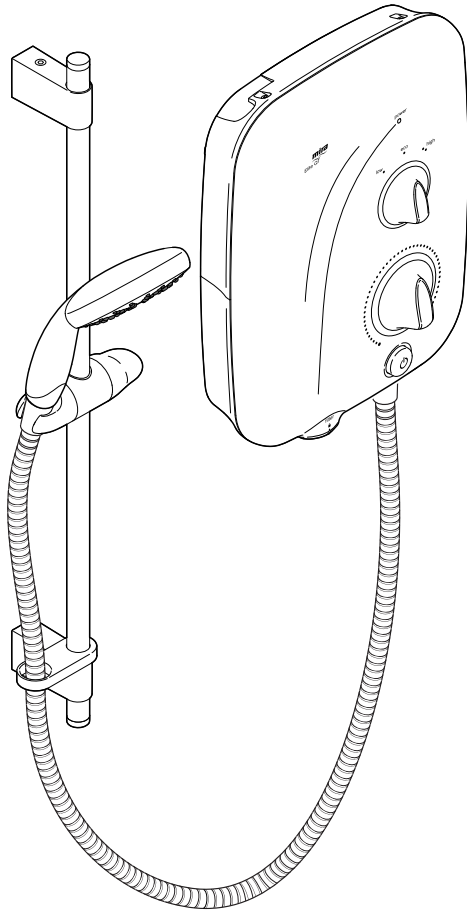

These instructions must be left with the user

Installation & User Guide

Showering perfection

mira
SHOWERS

Important Safety Information

WARNING! This shower can deliver scalding temperatures. For continued safe operation, follow all instructions, warnings and cautions contained in this guide and on or inside the shower unit. Failure to follow the instructions provided with the shower will invalidate the guarantee.

PLEASE OBSERVE THE FOLLOWING TO REDUCE THE RISK OF FIRE, ELECTRIC SHOCK OR INJURY:

INSTALLING THE SHOWER

- 1.** Installation of the shower must be carried out in accordance with these instructions by qualified, competent personnel. Read all instructions before installing the shower.
- 2.** Isolate the electrical and water supplies before commencing installation. The electricity must be isolated at the consumer unit and the appropriate circuit fuse removed, if applicable. Mains connections are exposed when the shower cover is removed.
- 3. DO NOT** install the shower in areas with high humidity and temperature (i.e. steam rooms and saunas).
- 4. DO NOT** install the shower where it may be exposed to freezing conditions. Ensure that any pipework that could become frozen is properly insulated.
- 5. DO NOT** connect the outlet of the shower to any tap, control valve, trigger handset or showerhead other than those specified for use with this shower. Only Kohler Mira recommended accessories must be used.
- 6. DO NOT** perform any unspecified modifications, drill or cut holes in the shower or fittings other than instructed by this guide. When servicing only use genuine Kohler Mira replacement parts.
- 7.** If the shower is dismantled during installation or servicing then, upon completion, an inspection must be made to ensure all electrical connections are tight and that there are no leaks.

USING THE SHOWER

- 8.** The shower must be operated and maintained in accordance with

the requirements of this guide. Make sure you fully understand how to operate the shower before use, read all instructions and retain this guide for future reference.

9. **DO NOT** switch the shower on if there is a possibility that the water in the shower unit or fittings is frozen.
10. **DO NOT** switch the shower on if water leaks from the shower unit. Isolate the electrical supply to the shower immediately.
11. **DO NOT** switch the shower on if the case appears to be damaged or incorrectly fitted. Isolate the electrical supply to the shower immediately.
12. The shower can be used by children aged from 8 years and above and persons with reduced physical, sensory or mental capabilities or lack of experience and knowledge if they have been given supervision or instruction concerning use of the appliance in a safe way and understand the hazards involved. Children must not be allowed to play with the shower.
13. **DO NOT** allow children to clean or perform any user maintenance to the shower unit without supervision.
14. Always check the water temperature is safe before entering the shower.
15. **DO NOT** increase the power setting or adjust the temperature control rapidly while using the shower.
16. Use caution when altering the water temperature, always check the temperature before continuing to shower.
17. **DO NOT** switch the shower off and back on while standing in the water flow.
18. **DO NOT** run the shower with the filter removed.
19. Switch the shower off at the electrical isolating switch when not in use. This is recommended with all electrical appliances.
20. **DO NOT** connect the outlet of the shower to any tap, control valve, trigger handset or showerhead other than those specified for use with this shower. Only Kohler Mira recommended accessories must be used.
21. The showerhead must be descaled regularly. Any blockage of the showerhead or hose can cause damage to the shower.

Introduction

Thank you for choosing a Mira shower. To enjoy the full potential of your new shower, please take time to read this guide thoroughly, and keep it handy for future reference. Products manufactured by Kohler Mira Ltd are designed to be safe, provided that they are installed, used and maintained in good working order, in accordance with our instructions and recommendations.

Follow all warnings, cautions and instructions contained in this guide, and on, or inside the shower. This guide is also available in digital format from our website or by contacting customer services.



Electrical and electronic devices contain a range of materials that can be separated for recycling and used in new products.

This product should not be disposed of with your general household waste. When this product has reached the end of its serviceable life please take it to a recognised WEEE (Waste Electrical and Electronic Equipment) collection facility such as your local civic amenity site for recycling. Your local authority or retailer will be able to advise you of your nearest recycling facility.

Mira Electric Showers covered by this guide:

Product	kW	Model Number	Colour
Mira Elite QT	9.8	J08I	White / Chrome
	10.8	J08J	

Guarantee

This product has been designed for **domestic use only**, Mira Showers guarantee this product against any defect in materials or workmanship for a period of **two** years from the date of purchase (shower fittings for **one** year).

For terms and conditions, refer to the back cover of this guide.

Recommended Usage

Recommended Usage	
Domestic	✓
Light Commercial	✗
Heavy Commercial	✗
Healthcare	✗

Pack Contents

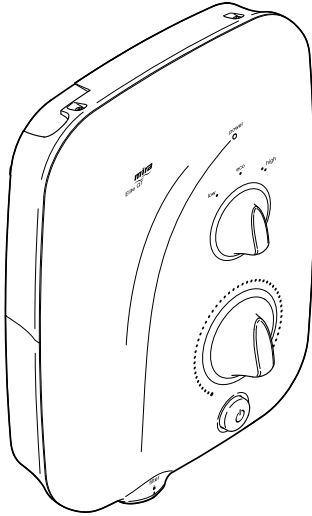

1 x Shower Unit

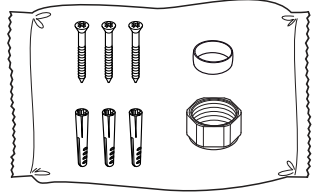

1 x Component Pack (shower unit)

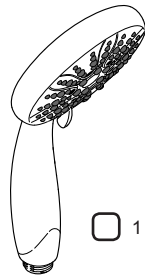

1 x Showerhead

2 x Caps

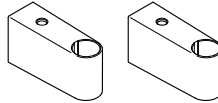

2 x Slide Bar Supports

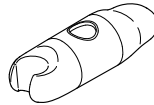

1 x Clamp Bracket



1 x Hose Retaining Ring

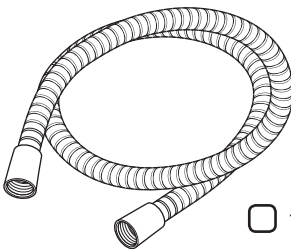

1 x Hose

2 x Washers

1 x Slide Bar

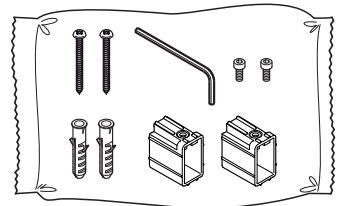

1 x Component Pack (shower fittings)

- 1 x Installation & User Guide
- 1 x Installation Template (remove from packaging)
- 1 x Guarantee Card

Specifications

Plumbing	
Maximum Static Pressure	100 kPa (1 bar)
Minimum Static Pressure	0.8 kPa (0.008 bar)
Minimum Inlet Temperature	2°C
Maximum Inlet Temperature	30°C
Maximum Water Hardness	200 ppm CaCO ₃
Inlet	15 mm compression. Adjustable for top, bottom or rear entry pipework.
Outlet	1/2" BSP Male to flexible hose
Electrical	
Power Supply	230 - 240 V, 50 Hz 9.8 kW model (230 V = 9.0 kW, 240 V = 9.8 kW) 10.8 kW model (230 V = 9.9 kW, 240 V = 10.8 kW)
Duty Cycle	Continuously rated.
Maximum Supply Cable Size	16 mm ²
Recommended RCD Rating	30 mA tripping current
Recommended Isolator Switch	Double-pole with 3 mm contact separation, 45 A
Recommended MCB Rating	9.8 kW model = 40 A 10.8 kW model = 45 A
Ingress Protection Rating	IP X4 - Suitable for installation in Zone 1
Minimum Ambient Temperature	2°C
Maximum Ambient Temperature	30°C
Dimensions (shower unit)	
Height	363 mm
Width	270 mm
Depth	110 mm

The Mira Elite QT complies with the following European directives:

2006/95/EC Low Voltage Directive, 2004/108/EC EMC Directive, 2011/65/EU RoHS Directive.

The Mira Elite QT is a high power appliance and is subject to conditional connection. If the main electrical supply fuse is rated less than 80 Amps, the local electricity supply company must be contacted to confirm if the electrical supply is adequate.

The Mira Elite QT complies with the requirements of the UK's water regulations.

Design Registration & Patents

Patents: GB 2 289 323, 2 341 667, 2 359 339, 2 427 460, 2 432 201

Ireland: 80655, 82835, 83692

Installation

Plumbing

1. The plumbing installation must comply with all national or local water regulations and all relevant building regulations, or any particular regulation or practice specified by the local water supply company.
2. The shower is designed to operate with a gravity fed water supply providing a pressure from 0.8 kPa* (0.008 bar / 80 millimetres head) to 100 kPa (1 bar / 10 metres head, the vertical distance from the base of the cold water cistern to the top of the shower unit). The shower must have its own separate supply from the cistern.

DO NOT FIT THE SHOWER TO A MAINS WATER SUPPLY OR WHERE THE MAXIMUM SPECIFIED PRESSURE MAY BE EXCEEDED!

Failure to comply with these restrictions may result in product damage not covered by the guarantee.

* **Note!** In practice the minimum head required will increase with pipe length. See **"Pipework"** for further guidance which includes a calculation table to make sure that adequate head is available for any given installation.

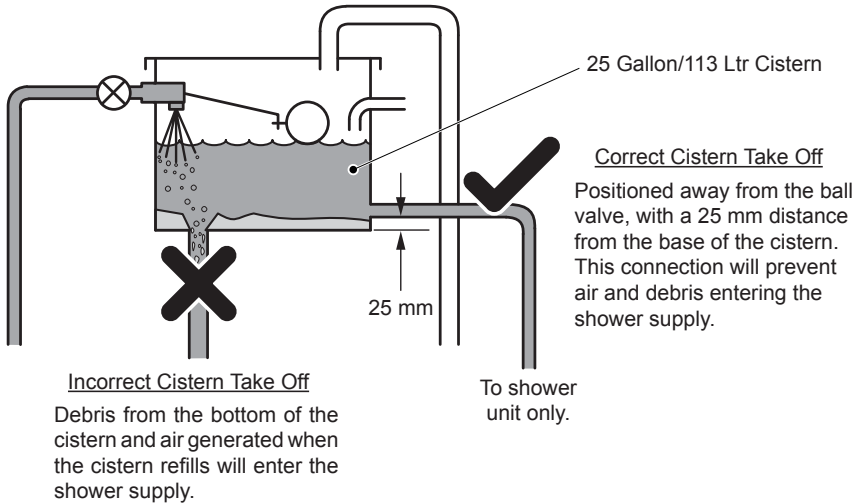

3. **DO NOT** install the product in a position or location that will limit access for servicing.
4. A suitable position for the shower will have a minimum clear distance of 200 mm above and below the shower unit to allow for cover removal and refitting.
5. The position of the shower and shower fittings must provide a minimum air gap of 25 mm between the showerhead and the spill over level of any bath, shower tray or basin. There must be a minimum distance of 30 mm between the

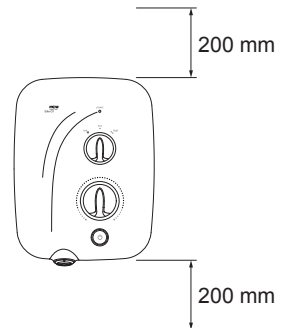

showerhead and the spill over lever of any toilet, bidet or other appliance with a Fluid Category 5 backflow risk.

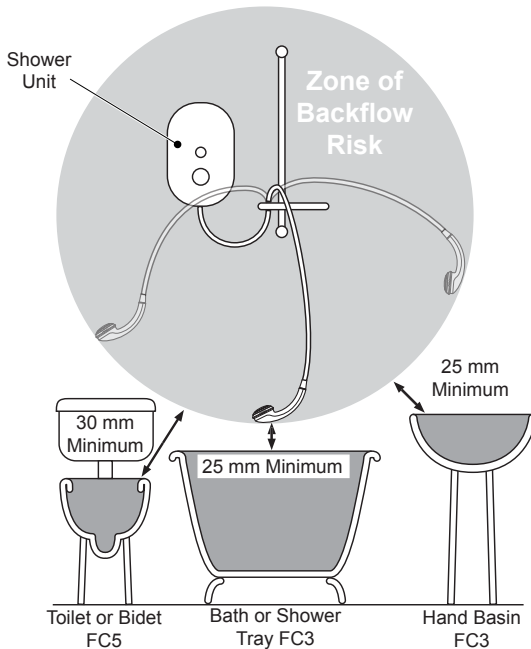

Note! There will be occasions when the hose retaining ring will not provide a suitable solution for Fluid Category 3 installations. In these instances an outlet double checkvalve must be fitted, this will increase the required supply pressure typically by 10 kPa (0.1 bar). Double checkvalves fitted in the inlet supply to the appliance cause a pressure build up, which affects the maximum static inlet pressure for the appliance and must not be fitted. For Fluid Category 5, double checkvalves are not suitable.

6. The shower is suitable for installation within the shower area. The shower is fitted with an internal pressure relief valve and must be installed over a water catchment area.
7. Position the shower where the controls area at a convenient height for the user. Position the showerhead so that the water sprays in line with the bath or across the opening of a shower cubicle. The showerhead must not spray directly onto the shower unit during normal use. The installation must not cause the shower hose to be kinked during normal use.
8. The shower must be fitted to a waterproof, flat and even wall surface. The 3 screws (No. 8 x 1¼") and wall plugs supplied are suitable for most solid wall installations. Alternative fixing screws for panel structures are not supplied. Use all 3 fixing points to secure the shower unit, be sure to use fixings appropriate for the chosen wall structure.
DO NOT fit the shower to the wall and tile up to the case or seal the gap between the shower and the wall surface with sealant.
9. The shower is intended to be permanently connected to a gravity fed water supply using the inlet connection supplied as part of the shower unit.
DO NOT use any other type of fitting.
10. Use a minimum of 15 mm diameter supply pipework. For long pipe runs, this should be increased to 22 mm (see "**Pipework**" for guidance and calculation table). When using flexible plastic pipe it is essential that the pipe is kept flat to minimise air build up in the system.
11. A full bore/non restrictive servicing valve must be fitted in a readily accessible position adjacent to the shower to facilitate maintenance of the shower.

DO NOT use a valve with a loose washer plate (jumper) as this can lead to a build up of static pressure.

12. The shower is not designed to be plumbed directly from the rear. For rear-entry supply, add an elbow to the supply pipe and connect as a rising or falling supply. We recommend a falling supply to prevent air lock in the pipework.
13. If pipework and/or electrical cables enter the shower from the rear through a hole in the wall, provision must be made to prevent water ingress back into the wall structure.
14. **DO NOT** apply excessive force to plumbing connections; always provide mechanical support when making plumbing connections. Any soldered joints should be made before connecting the shower.
15. A water treatment device should be installed where the water hardness may exceed 200 ppm. Malfunctions caused by excessive limescale formation are not covered by the guarantee.
16. **DO NOT** perform the electrical installation until the plumbing has been completed and checked for leaks.
17. The water supplies to this product should be isolated if the product is not to be used for a long period of time. If the product or pipework is at risk of freezing during this period they should also be drained of water.

Pipework

Long pipe runs and excessive use of 90° elbow fittings will significantly reduce the available head to supply the shower unit. The pipework table provided should be used to ensure that an adequate pressure is available for any given application.

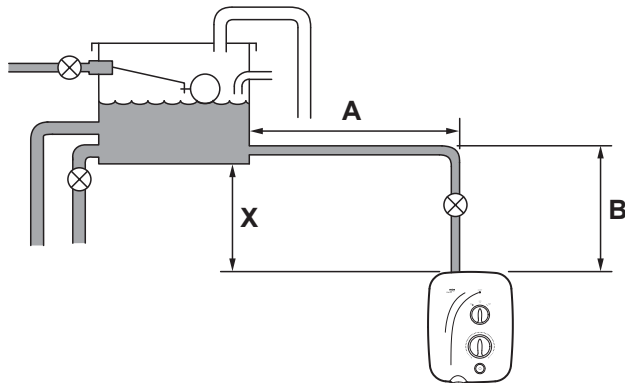

Pipework Schematic Diagram

Use the following table to calculate the dimension (x) to give a minimum effective head of 80 mm required to produce a satisfactory shower in all conditions.

The example below is based on the **“Pipework Schematic Diagram”** with 15 mm pipework, A = 1.5 m, B = 0.75 m.

Size	Quantity	Head Loss (mm)
15 mm Pipe	(A) <u>1.5</u> + (B) <u>0.75</u> = <u>2.25</u> x 120	270
22 mm Pipe	(A) ___ + (B) ___ = ___ x 20	
15 mm Elbow	Number of Elbows <u>1</u> x 55	55
22 mm Elbow	Number of Elbows ___ x 15	
		Minimum Effective Head
		80
		(X) mm
		405

Electrical

1. The electrical installation must comply with BS 7671 (commonly referred to as the IEE Wiring Regulations) and all relevant building regulations, or any particular regulation or practice specified by the local electricity supply company.
2. Ensure that all circuit protection devices, switches and cabling are adequate for the rated current of the shower and that the rating of the electricity supply company fuse and the consumer unit are adequate for the additional demand.
3. The shower must be earthed. Ensure that any supplementary bonding complies with the relevant regulations.
4. The shower is intended to be permanently connected to the fixed electrical wiring of the mains system. A separate supply must be provided from the consumer unit to the shower.
5. The shower must be provided with means for local disconnection that is incorporated into the fixed wiring in accordance with the relevant local wiring regulations. This must be a double pole switch, which has at least 3 mm contact separation in each pole. The switch can be a pull-cord type mounted to the ceiling within the shower room or a rocker type switch mounted to the wall in the applicable zone area.
6. For new installations a 30 mA Residual Current Device (RCD) must be incorporated into the electrical supply to the shower in accordance with the current wiring regulations. When replacing an existing electric shower we recommend that a 30 mA RCD is incorporated in accordance with current wiring regulations if not already provided.

7. Check all electrical connections are tight, to prevent overheating, before switching on the electrical supply.
DO NOT apply excessive force to the terminal block.
8. **DO NOT** supply any other electrical equipment including extractor fans or pumps via the shower unit.
9. **DO NOT** switch on the electrical supply until the plumbing has been completed and checked for leaks.

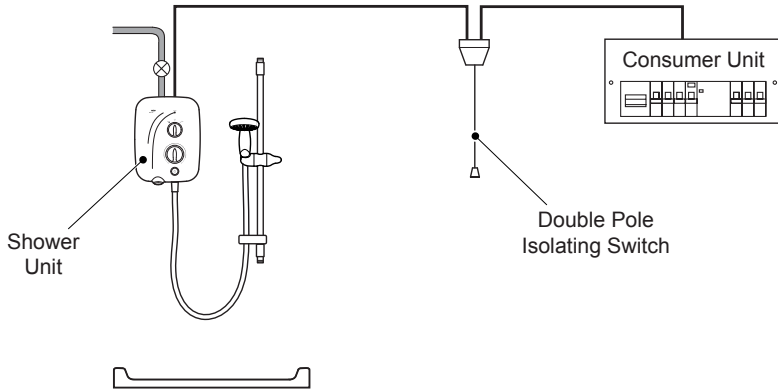

Electrical Schematic Diagram

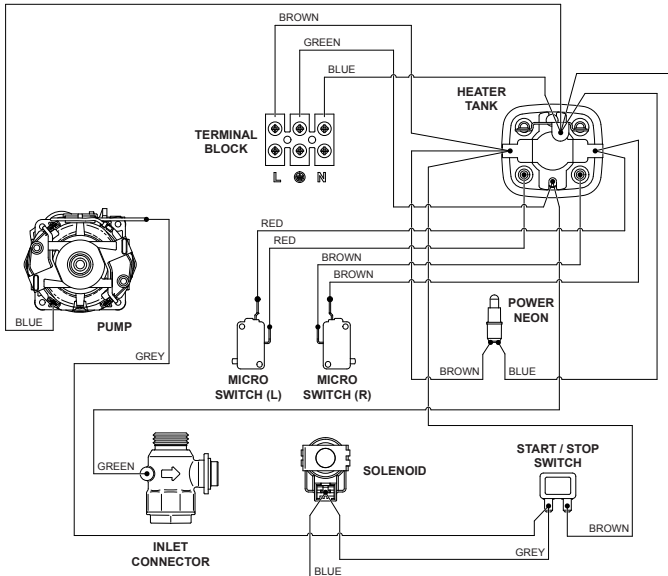

Shower Unit Wiring Diagram

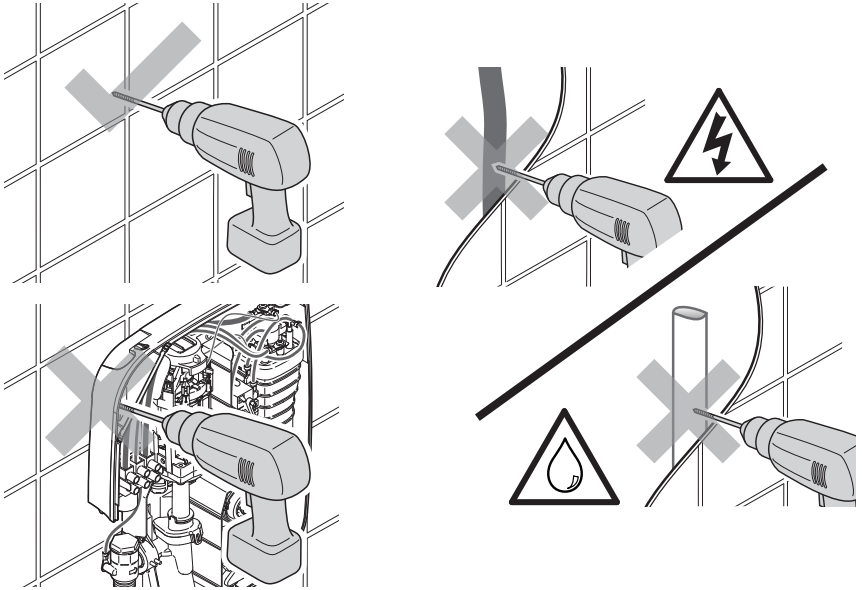
4

Drill the fixing holes.

DO NOT drill through the shower unit into the wall.

DO NOT drill into buried cables or pipes.

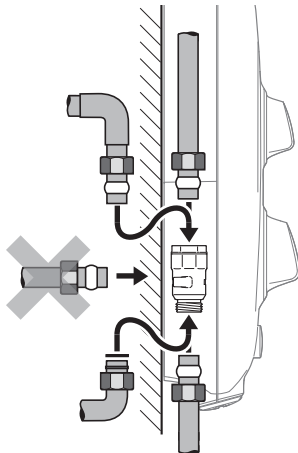
5

Feed the water pipe and electrical cable to the inlet of the shower unit. For rear inlet, use an elbow fitting. We recommend a falling supply to prevent air lock in the pipework.

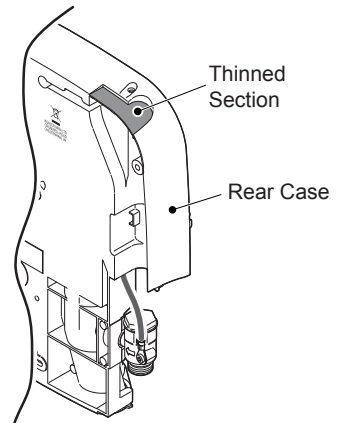
6

For a falling water supply pipe, carefully remove the thinned section of the rear case using an appropriate cutting tool.

6

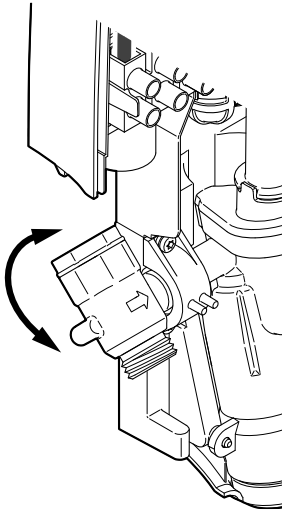

Thoroughly flush the water supply pipe. Rotate the inlet connector to suit the direction of the water supply.

7

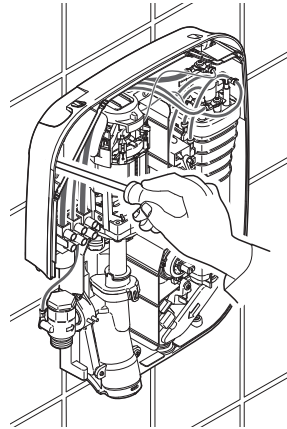

Fix the shower unit to the wall, 3 x No. 8 x 1¼" screws and wall plugs are supplied. See **"Installation - Plumbing"** for further details.

8

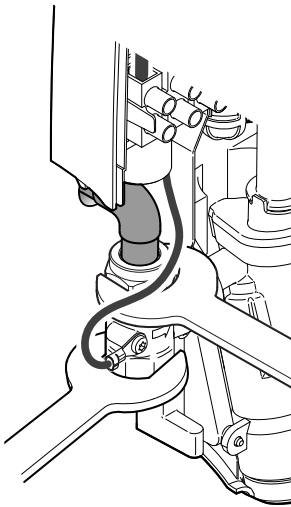

Connect the water pipe to the shower unit.

DO NOT use jointing paste.
DO NOT overtighten the fitting.
DO NOT trap the green wire.

9



Turn the water supply on and check the shower unit for leaks.

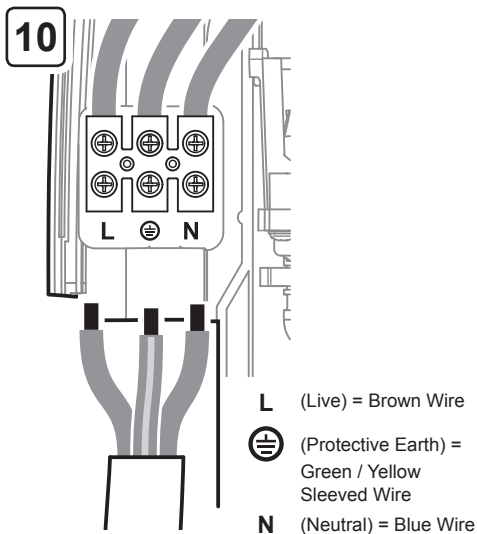

Turn the water supply back off. Feed the electrical cable into the shower unit. Strip the insulation and fit an earth sleeve (not supplied). Secure the wires firmly into the terminal block.

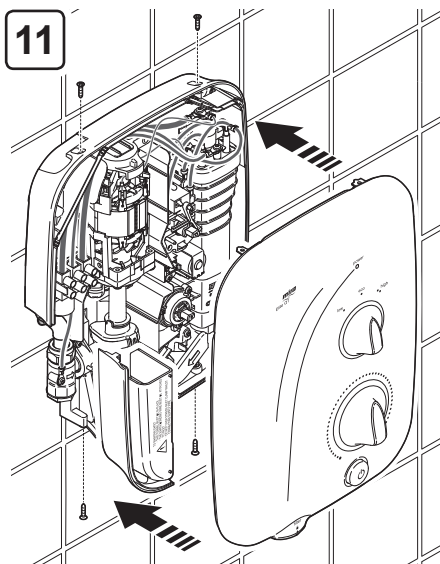

Refit the service tunnel. Align the controls with the spindles and refit the cover. Secure with screws supplied.

DO NOT trap any wires.

DO NOT use alternative screws to secure the cover. This can cause internal damage to the shower unit.

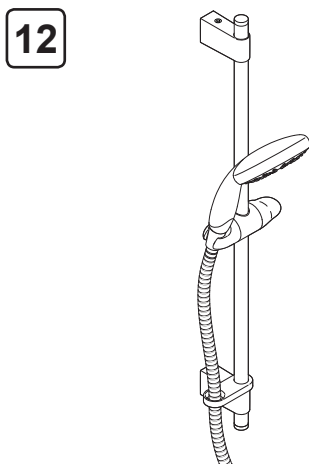

Install the shower fittings provided with this shower, see **“Installation of the Shower Fittings”**.

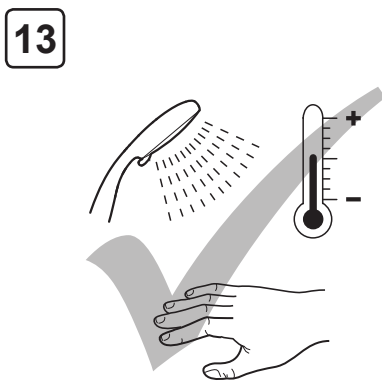

The shower must be commissioned before use, see **“Commissioning”** for full instructions.

Installation of the Shower Fittings

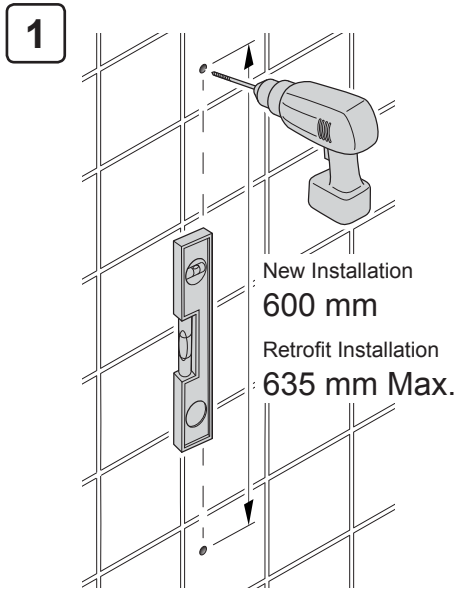

Mark and drill the fixing points for the wall screws. New installations at a distance of 600 mm. Retrofit installations up to a maximum distance of 635 mm.

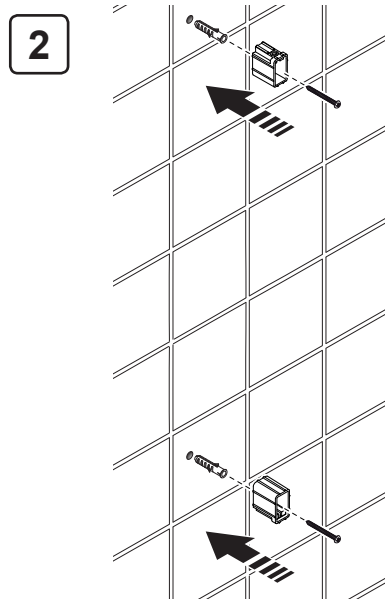

Fix the brackets to the wall, 2 x No. 8 x 45 mm screws and wall plugs are supplied. Use appropriate screws for the wall structure and use a spirit level to align the brackets vertically.

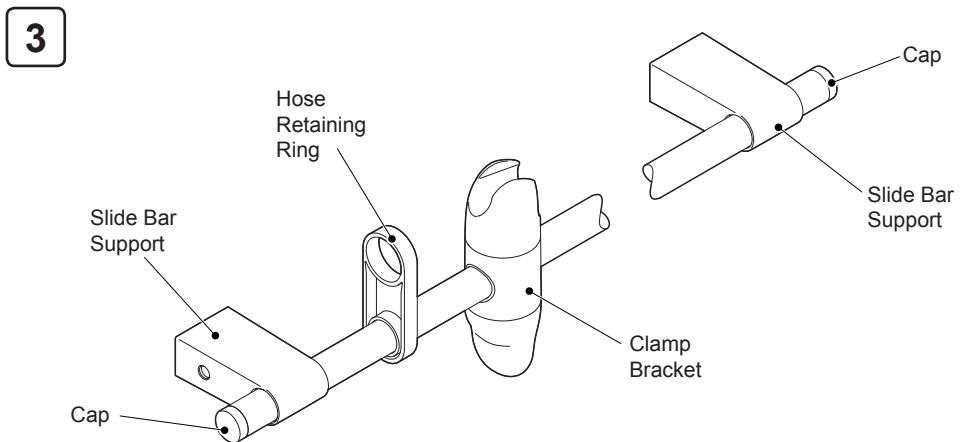

Assemble the clamp bracket, hose retaining ring, slide bar supports and caps to the slide bar.

4

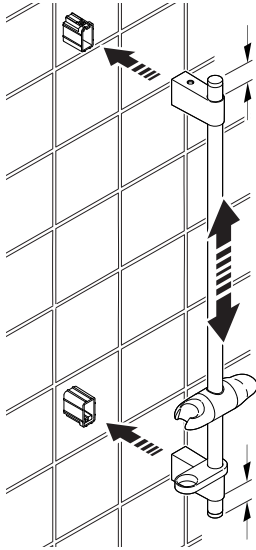

Fit the slide bar supports over the mounting brackets and adjust the slide bar vertically. The slide bar should extend equally at both ends.

5

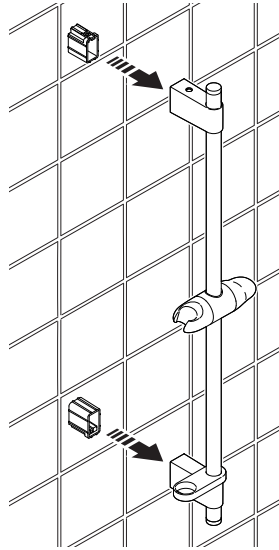

Remove the assembly, without moving the supports on the slide bar.

6

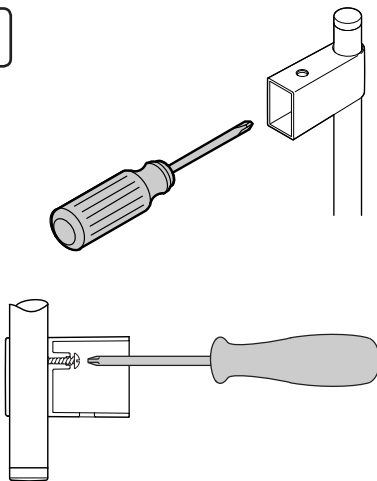

Tighten the two slide bar clamping screws no more than half a turn to secure the slide bar supports to the slide bar.

Caution! Overtightening these screws will cause damage.

7

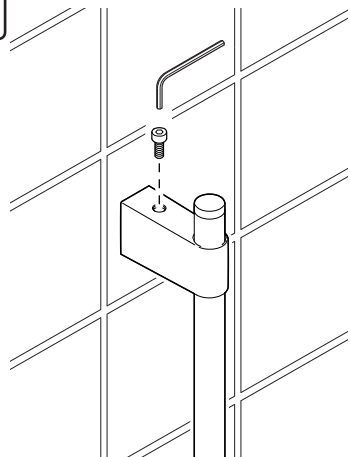

Fix the slide bar at both ends with the M4 screws supplied.

8

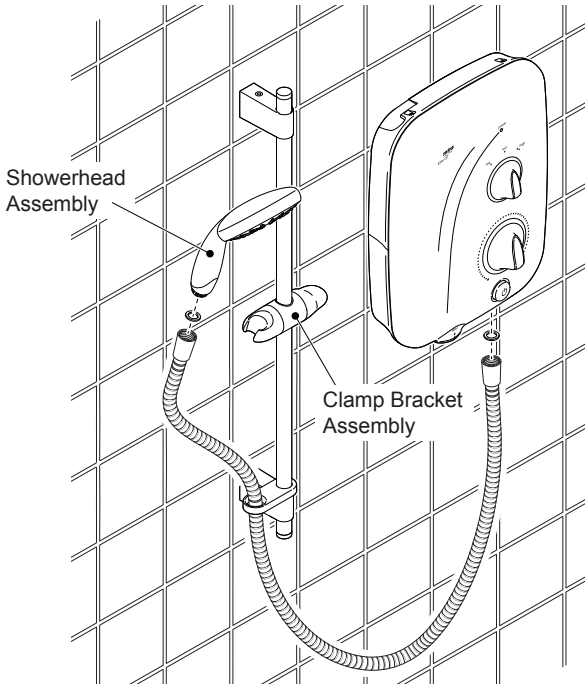

Feed the hose through the retaining ring and screw to both the showerhead and shower unit. Use the washers supplied to seal the connections. Place the showerhead assembly into the clamp bracket assembly and check the operation. Turn the water supply back on.

Commissioning

Follow this procedure to check the function and performance before using the shower for the first time. **Make sure that all users are familiar with the operation of the shower. This guide is the property of the homeowner.**

1

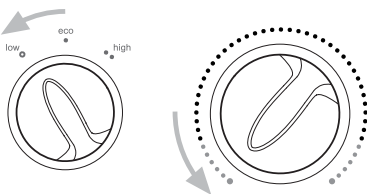

Turn power control to **low**.
Turn temperature control to **full cold**.

2

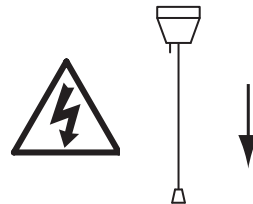

Switch electrical supply **on**.

3



Start shower running, water is cold and at maximum flow.

4

AIR IN SYSTEM ?

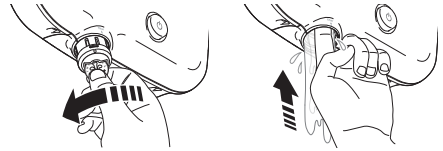

Turn shower off.
Remove filter from shower unit.
Push rod up until water flows freely.
Refit filter, turn until locked.

5

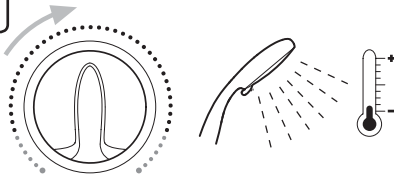

Turn temperature control to **mid-temperature**. Water remains cold, but flow is reduced.

6

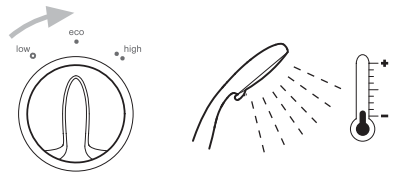

Turn power control to **eco**. Water temperature rises, but stays cool.

7

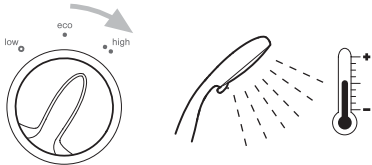

Turn power control to **high**. Water temperature rises further.

8

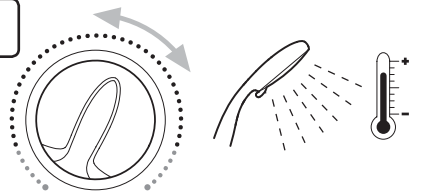

Turn temperature control to test water temperature change. Water flow adjusts automatically as you adjust the temperature.

9

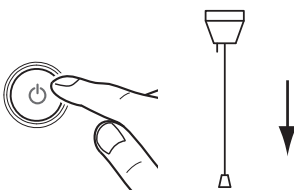

Stop shower and switch electrical supply **off**.

10



Residual water may drain for a few minutes.

Operation

Please read **“Important Safety Information”** before using the shower for the first time.

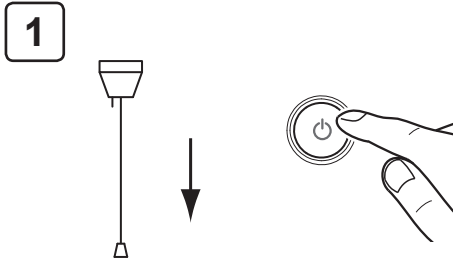

Switch electrical supply **on** and start shower.

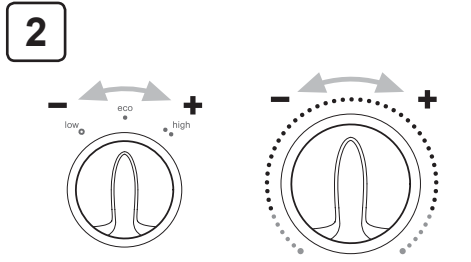

Set power control to **low / eco / high**. Adjust temperature control until desired showering temperature is reached.

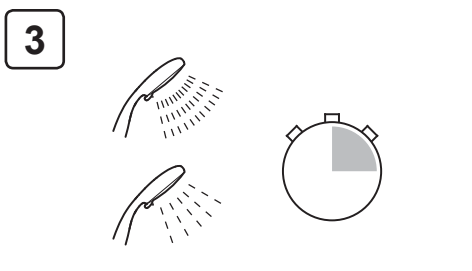

Allow a few seconds for any temperature adjustment to take effect. Allow temperature to stabilise before making a new adjustment.

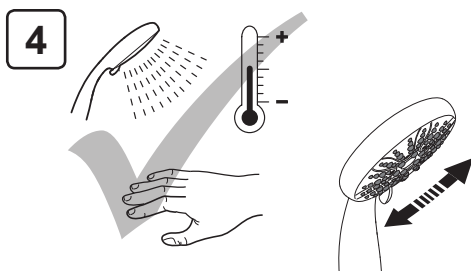

Check water temperature before entering shower. Spray pattern can be adjusted while showering.

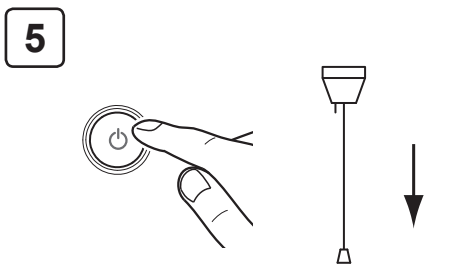

Stop shower and switch electrical supply **off**.

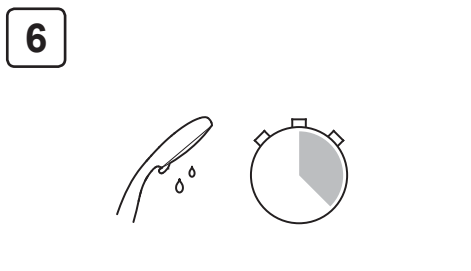

Residual water may drain for a few minutes.

Please note when altering the shower temperature...

CAUTION! Altering the temperature control rapidly can cause the water temperature to become briefly hotter or colder than required. For best results, adjust the temperature control a small amount and allow the temperature to stabilise. Continue to adjust until a comfortable showering temperature is reached.

DO NOT increase the power setting while standing in the water flow. Avoid changing the power setting when the shower is in use, this can cause a large increase or decrease in water temperature.

DO NOT switch the shower off and back on while standing in the water flow. Cycling the shower off/on may result in unstable water temperatures. Always ensure the temperature has stabilised before re-using the shower.

The shower has a high performance pump installed, which has been acoustically designed for quieter performance, but will produce some noise during operation. Pump tone may change when altering temperature position.

Effect of Seasonal Changes

The temperature of the mains water feed to the cistern is not constant throughout the year, i.e. cooler during winter, warmer during summer. To maintain the desired showering temperature, adjust the power and temperature controls accordingly. The shower flow rate will adjust automatically.

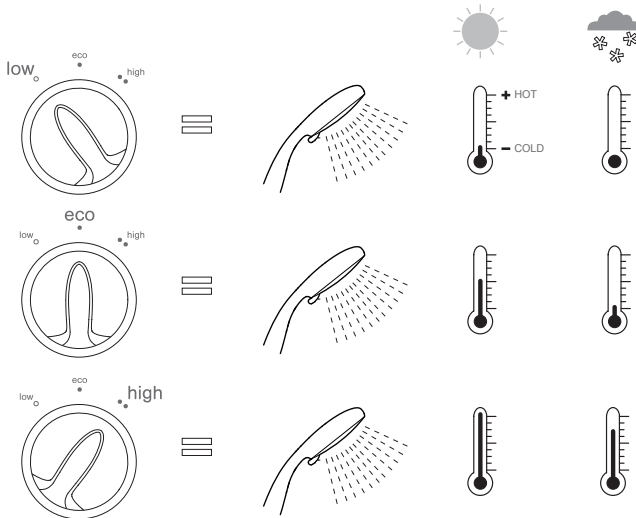

For a cold shower select **low**.

For a summer warm shower select **eco / high**.

For a winter warm shower select **high**.

Adjust the power and temperature controls as required.

Flow rate will reduce when temperature control is increased.

User Maintenance

WARNING! PLEASE OBSERVE THE FOLLOWING TO REDUCE THE RISK OF FIRE, ELECTRIC SHOCK, INJURY OR PRODUCT DAMAGE:

- No user serviceable parts can be accessed by removing the cover. Mains connections are exposed when the cover is removed. Only qualified, competent personnel should remove the cover.
- Isolate the electricity to the shower unit before cleaning or performing any user maintenance.
- **DO NOT** allow children to clean or perform any user maintenance to the shower unit without supervision.
- **DO NOT** use the showerhead to clean the shower unit.
- If the shower is not to be used for a long period, the electrical supply and water supply to the shower unit should be isolated. If the shower unit or pipework is at risk of freezing during this period, a qualified, competent person should drain them of water.

Cleaning / Replacing Filter

The filter can be safely removed from the lower left of the shower unit. Isolate the electrical supply to the shower unit before removing the filter. The water supply will shut off automatically as the filter is removed, however we recommend isolating the water supply to the shower unit to aid with refitting the filter.

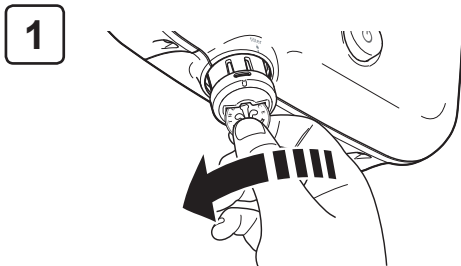

Insert a suitable coin or an 8 mm hexagonal key into the cap and turn to the left.

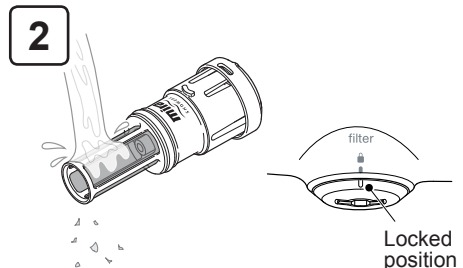

Rinse the filter in clean warm water removing any dirt or debris. Replace if the filter mesh is damaged. Make sure the filter is correctly refitted to the locked position.

Cleaning

Many household cleaners contain abrasives and chemical substances, and should not be used for cleaning plated or plastic fittings. These finishes should be cleaned with a mild washing up detergent or soap solution, and then wiped dry using a soft cloth.

Important! The showerhead must be descaled regularly. Keeping the shower spray clean and free from limescale will ensure that your shower continues to give the best performance. Limescale build up can restrict the flow rate and may cause damage to your shower.

The shower hose should be inspected periodically for damage or internal collapse. Any restriction to the water flow from the showerhead and may cause damage to the shower. Remove the shower hose from the shower, inspect and replace the hose if necessary.

Fault Diagnosis

If any of the following conditions occur, isolate the electricity and water supplies and contact Kohler Mira Customer Service.

- If the case is damaged or the cover is not correctly fitted and water has entered the shower case.
- If the shower begins to make an odd noise, smell or smoke.
- If the shower shows signs of a distinct change in performance indicating a need for maintenance.

Only use genuine Kohler Mira replacement parts.

If you require a Mira trained service engineer or agent, please see “**Customer Service**” on the back cover of this guide.

Symptom	Cause	Recommended Action
Shower fails to operate.	Electrical supply isolated.	Switch on shower via pull cord or wall switch.
	Fuse blown or MCB/RCD tripped.	Reset the MCB/RCD. Replace fuse. If fault persists, contact your installer.
Low water flow. No water flow.	Hose or shower head blocked. Filter blocked or removed.	Remove and clean. Check hose and replace if necessary. Refit all parts correctly.
	Water supply isolating valve set too low or turned off.	Fully open isolating valve.
	Air in system.	Refer to “ Commissioning ” and bleed air by removing filter.
	Insufficient water pressure or water flow for shower operation.	Gravity fed system, minimum pressure 0.8 kPa. (0.008 bar / 80mm head.)
	Flow Valve faulty.	Contact your installer to replace.
	Heater Tank excessively scaled.	Contact your installer to replace. Consult your installer about fitting a water softener for hard water areas.

Symptom	Cause	Recommended Action
Low water flow. No water flow. (continued...)	Pump overheated or faulty.	Wait 30 minutes for pump to cool and reset automatically. If fault persists, contact your installer to replace.
Water flow stops and motor tone increases.	Stored water is blocked or has run out.	Turn shower off immediately! Make sure there is a constant water supply when shower is in use.
	Air in system.	Refer to “ Commissioning ” and bleed air by removing filter.
Water will not turn off.	Shower’s Flow Valve, Solenoid or Start/Stop switch has failed.	Contact your installer to replace parts as required.
Shower cycles from hot to cold.	Controls are set too high.	Turn the power control to eco and readjust the temperature control.
	Filter, Hose or shower head blocked.	Remove and clean. Check hose and replace if necessary.
Unable to select a cool enough temperature.	Stored water temperature has increased.	Turn the power control to eco and readjust the temperature control.
	Filter, Hose or shower head blocked.	Remove and clean. Check hose and replace if necessary.
Shower head drips constantly.	Shower’s Flow Valve has failed.	Contact your installer to replace.
No change in temperature of low / eco / high settings.	Shower’s Flow Valve, Microswitch or Heater Tank has failed.	Contact your installer to check the continuity of the Microswitch or Heater Tank and replace parts as required.
The temperature control has little or no effect on water temperature.	Filter, Hose or shower head blocked.	Remove and clean. Check hose and replace if necessary.
	Shower’s Flow Valve (joined to the Heater Tank) has failed.	Contact your installer to check the Heater Tank and replace parts as required.
No hot water when set to eco / high .	Shower’s Flow Valve, Microswitch or Heater Tank has failed.	Contact your installer to check the continuity of the Microswitch or Heater Tank and replace parts as required.

Spare Parts

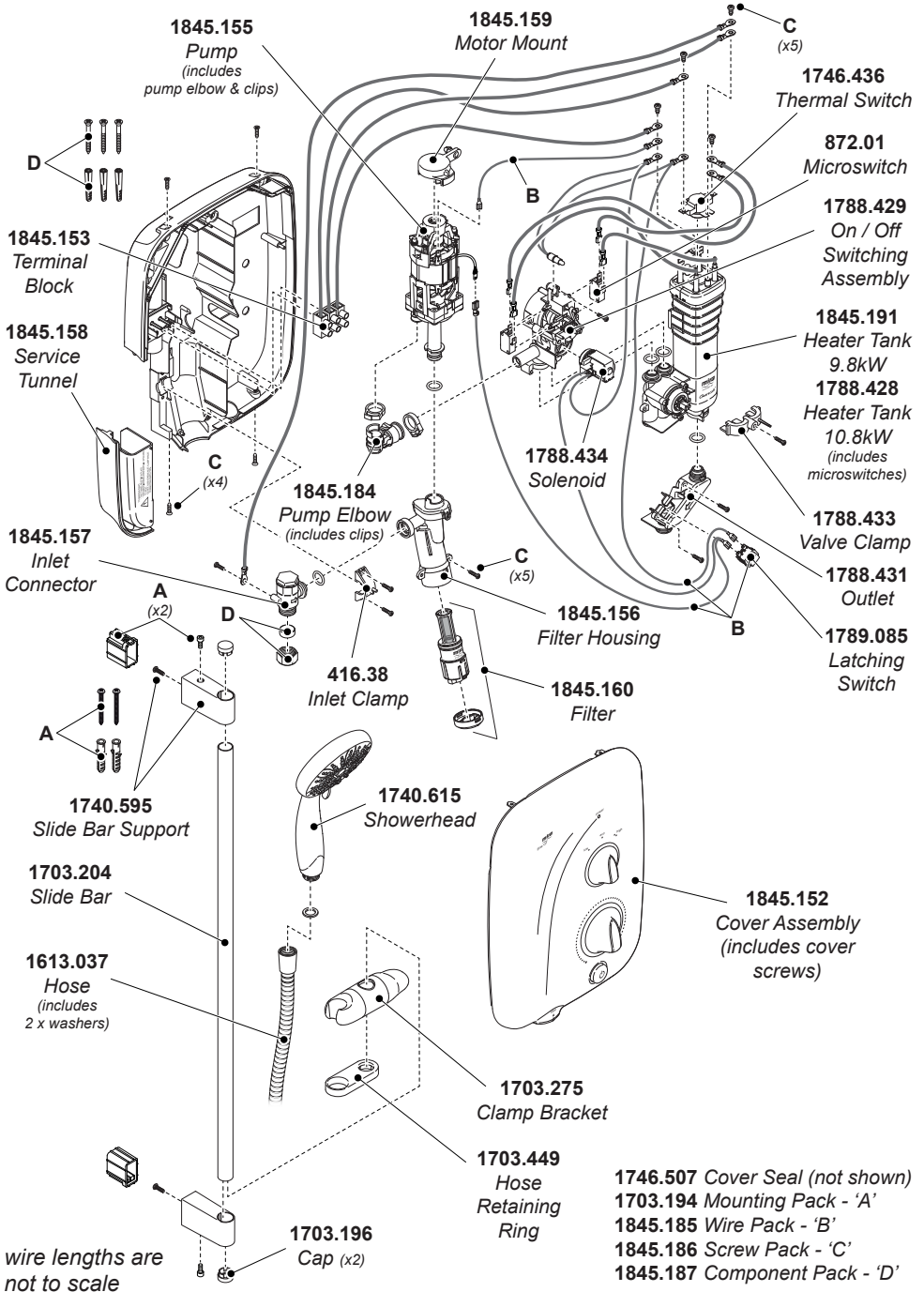

Notes

Notes

Customer Service

Guarantee

Your product has the benefit of our manufacturer's guarantee which starts from the date of purchase. This guarantee only applies in the United Kingdom and Republic of Ireland. To activate this guarantee, please return your completed registration card, visit our website or free phone **0800 5978551** within 30 days of purchase (UK only).

Within the guarantee period we will resolve defects in materials or workmanship, free of charge, by repairing or replacing parts or product as we may choose.

This guarantee is in addition to your statutory rights and is subject to the following conditions:

- The guarantee applies solely to the original installation under normal use and to the original purchaser only. The product must be installed and maintained in accordance with the instructions given in this guide.
- Servicing must only be undertaken by us or our appointed representative.
Note! If a service visit is required the product must be fully installed and connected to services.
- Repair under this guarantee does not extend the original expiry date. The guarantee on any replacement parts or product ends at the original expiry date.
- For shower fittings or consumable items we reserve the right to supply replacement parts only.

The guarantee does not cover:

- Call out charges for non product faults (such as damage or performance issues arising from incorrect installation, improper use, inappropriate cleaning, lack of maintenance, build up of limescale, frost damage, chemical attack, corrosion, system debris or blocked filters) or where no fault has been found with the product.
- Water or electrical supply, wast and isolation issues.
- Compensation for loss of use of the product or consequential loss or indirect loss of any kind.
- Damage or defects caused if the product is repaired or modified by persons not authorised by us or our appointed representative.
- Routine maintenance or replacement parts to comply with the requirements of the TMV2 or TMV3 healthcare schemes.
- Accidental or wilful damage.
- Products purchased ex-showroom display.

What to do if something goes wrong

If your product does not work correctly refer to this guide for fault diagnosis and check that it is installed and commissioned in accordance with our instructions. If this does not resolve the issue, contact us for help and advice.



Helpdesk Service

Contact our Customer Service Team for product advice, to purchase spare parts or accessories or to request a service visit. You can contact us via phone or e-mail - contact details below. Please provide your model name, power rating (if applicable) and date of purchase.



Mira Showers Website

(www.mirashowers.co.uk)

Visit our website to register your guarantee, download user guides, diagnose faults, purchase our full range of accessories and popular spares, or request a service visit.



Spares and Accessories

We hold the largest stocks of genuine Mira spares and accessories. Contact us for a price or visit our website to purchase items from our accessory range and popular spares. (Only available in the United Kingdom.)



Service/Repairs

No one knows our products better than our nationwide team of Service Technicians. We carry out service or repair work to your product both during and after the guarantee period. (Only available in the United Kingdom and Republic of Ireland.) Ask about our fixed price service repairs.

To Contact Us: UK



0844 571 5000

Please note: Calls cost 7p per minute plus your phone company's access charge.



01242 282595



Email - Visit

www.mirashowers.co.uk/contactus



By Post:

**Mira Customer Services Dept, Cromwell Road,
Cheltenham, Gloucestershire, GL52 5EP**

To Contact Us: Eire Only



01 531 9337



Email -

CustomerServiceEire@mirashowers.com

*Mira is a registered trade mark of
Kohler Mira Limited.*

*The company reserves the right to alter
product specifications without notice.*



FM 14648

mira
SHOWERS