

Acoustic door holder fitting instructions

AGRIPPA



Fitting the holder

Decide where the door holder will be mounted (at least 650 mm from the door hinge). For doors fitted with overhead closers, a position towards the top of the door is best. Mark the position for the keeper plate on the door.



Check the rubber ring is fitted before screwing the keeper plate to the door.



Screw the keeper plate onto the door.



Align the keeper plate with the magnet face.



Use the paper template supplied to drill holes in the wall.

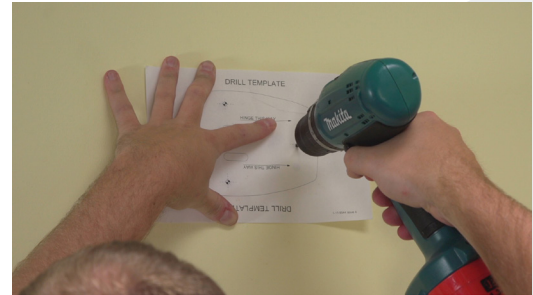

Remove the lid and fit the holder securely to the wall using three screws.



Fit the supplied batteries (2 x "C" cells). Note, the correct orientation is marked in the battery compartment. The motor will turn for around five seconds.

Fit the lid. The red dot will illuminate and after 10 seconds the magnet will turn on, **providing the background noise is low.**

You must now teach the holder the alarm sound as explained in the 'Learning the Alarm' section (see page 2).

If the holder is fitted to a left hand door, command option 2 may be selected to make the display easier to read (see page 3).

Do not put the door holder into use without performing a fire test to check that the door releases. Refer to the testing section.

Sounder locations

When fitting an Agrippa door holder, take note of where the nearest sounder is. If there is a door between this unit and the nearest sounder, before following the 'Learning the Alarm' section, make sure the door between the unit and the sounder is closed so that the unit is learnt in the 'worst case' ensuring it releases in a fire.

Learning the alarm

Remove the lid and press ENT. The display will show 0.



Press INC and the display will show 1.
Press ENT to select option 1.

Three flashing lines show that it is ready to learn.
Put the lid on the holder. Open the door until it is held by the magnet (the lid must be fitted before the magnet will turn on).



The unit is ready to learn.

Sound the fire alarm and press the red release button to start recording. **There must be no background noise while the alarm is recording.**



The display changes to show that it is recording.
This takes around 15 seconds.

The door will release once the recording has finished. You can now switch off the alarm.



The holder takes another two minutes to process the sound. This is indicated by the rotating pattern on the display.

Once the red dot lights, the door holder is ready to use.

N.B. If the unit is left for more than 20 minutes in option 1 without starting the learn cycle, the learn mode will time out.

Bells as alarms

If the alarm sound is generated by a bell, you may find that the Agrippa is sensitive to general background noise after the learning process. The red dot will often stay lit and the door may not hold or release. This can be improved by removing the lid and selecting command option 9 (see page 3).

This can be done any time after completing the learning process as long as the Agrippa has not been returned to default settings. Once selected, the display will show a rotating pattern for around 10 seconds. Replace the lid.

If the holder has already been returned to default settings, you will have to repeat the learning process before selecting option 9.

Noisy doors and keepers

When doors are near to each other, note whether any of the doors make a noise when closing whether due to the closing mechanism, the door slamming shut, or a chain keeper knocking against

the door surface. If this is the case, doors need to be put through the learn cycle separately to stop a unit hearing this noise and having the noise skew its sound processing.

Daily timed release

You can set a daily time when the door holder will release. It will then stay released until another set time when it will reactivate.

Times are entered in 24 hour format.

The current time, release time and a resume-hold time must be set before this function will work.

If the batteries are removed, the current time must be reset.

To set the current time, remove the lid then press the ENT button. 0 is displayed.

Press the INC button until 4 is displayed. Press ENT and 4 will flash.

This example shows how to enter a time of 3:20 pm or 15:20.

Press the INC button until 1 is displayed. Press ENT. The tens of hours is now set.

Press the INC button until 5 is displayed. Press ENT. The hour is now set.

Press the INC button until 2 is displayed. Press ENT. The tens of minutes is now set.

Press the INC button until 0 is displayed. Press ENT.

The time is now set and the display is blank.

Now set the release time using command option 5 and the resume-hold time using command option 6. Enter the time in the same way as shown above.

Command option 7 can be used to check the times that have been set. Select this option to display the current time, the release time and the resume-hold time. The 12 digits are displayed sequentially. Refit the lid when complete.



Release/reset button

If the magnet is holding normally, pressing the red button will release the door. The display will show the battery level.

If the holder is not magnetised, press the red button to reset. The display will show why the magnet is off. If, after 10 seconds of listening, no alarm is detected (and the holder is not in timed release or low battery) the magnet will turn on.

Command options

Remove the lid and press the ENT button to enter command mode. Press the INC button until the number for the required option is displayed then press ENT to select that option.

Option 1. Learn - see over page.

Option 2. Use this option if the numbers on the display are upside down.

Option 3. Restore default settings with a level of approximately 70dB. This will replace any settings previously entered.

Option 4. Set time - enter the current time in 24 hour format. Note that this must be re-set if the batteries are removed.

Option 5. Release time - enter the time at which the magnet will release. Enter 0000 to cancel.

Option 6. Resume-hold time - enter the time at which the magnet will turn back on.

Option 7. Display time - display the current time, the release time and the resume-hold time.

Option 8. Set release setting to approximately 65dB. This will replace any previous settings. Note that at this low sound level, the unit is susceptible to false releases from background noise.

Option 9. Alarm bell setting. Use if the alarm sound is produced by a bell and the holder is too sensitive to background noise. Only select after the learning process has been completed (see page 2).

For a step by step video fitting tutorial, visit our vimeo account at: www.vimeo.com/geofire

Display messages

The messages shown when the red button is pressed are below. You may need to select option 2 to turn the display the right way up.

New batteries will display b9.

If b0 is shown, fit new batteries.

A flashing bL indicates the batteries are critically low. The door will not hold until the batteries are replaced.

Flashing A. The door is released because of an alarm.

Flashing F. The door is released due to a timed release.

Flashing E followed by 1. The batteries are too low to learn the the alarm sound.

Flashing E followed by 2. The lid has not been fitted for recording the alarm sound.

Flashing E followed by 3. The red button has not been pressed to start the learn process within 20 minutes.

Flashing E followed by 4. The sound level detected in the learn process is below 65dB and the default parameters of 70dB have been used.

Flashing E followed by 5. The sound level detected in the learn process was found to be intermittent but its timing could not be identified. The sound levels detected are set but the holder may be slow in waking up. It is recommended a different alarm pattern is used on the sounder.

Flashing E followed by 6. The intermittent sound level detected during the learn process is below 65dB and the default parameters of 70dB have been used.

Flashing E followed by 7. The unit has not been put through the learn cycle or has been set back to default settings. Perform a learn process before choosing option 9 (see learning the alarm).

Testing

1. Open the door so that it is held by the door holder.
2. Check that any doors between the holder and the nearest fire sounder are closed.
3. Sound the fire alarm.
4. The holder will release within 20 seconds.
5. Check that the door closes fully.
6. Press the red button to reset the magnet. If the button is not pressed, the holder will reset automatically after 30 minutes.
7. If the door does not release, follow the instructions in the learning process section.

The test can be accelerated by holding the red release button for four seconds. After 10 seconds, the red dot will flash every second. In this mode the holder will respond to a typical alarm sound in about five seconds. The holder will return to normal operation after it has detected an alarm or five minutes after the button is pressed.

Maintenance

Check all fire doors release and close as part of a weekly fire test routine. In normal operation, the holder will release within 20 seconds of the alarm sounding.

Replace the batteries annually or when indicated by a low battery warning. Simply remove the cover, remove the old batteries, and replace with new batteries. The unit will hold automatically when the cover is replaced and the unit has detected a quiet state. There is no need to put the unit through the learn cycle again. If a release time has been programmed, the current time will need to be entered as per the 'Daily Timed Release' section.

Keep the faces of the magnet and keeper plate clean and free from damage.

Specification

Holding force	200N
Power	2 x alkaline "C" Cells
Typical battery life	12 months +
Default Release Volume	70 dB

Patented in the United Kingdom under patent number 2507582

CE	Stephenson Gable Ltd Bishop Auckland DL14 6XB England	13					
	1121-CPD-AE0019	EN115:1997+A1:2002	3	5	5	1	1

- DIGITAL ACOUSTICALLY TRIGGERED DOOR HOLDER
- LEARNS THE SOUND OF YOUR FIRE ALARM
- EASY, WIRE FREE INSTALLATION AND PROGRAMMING
- DAILY TIMED RELEASE OPTION
- 200 N HOLDING FORCE
- TWO ALKALINE C CELL BATTERIES
- APPROVED TO EN1155 AND CE MARKED



The Agrippa door holder learns the sound of your specific fire alarm, releasing the door in the event of a fire.

This new innovation in the industry is also wire free, so it can easily be retrofitted to any door. The releasing trigger reacts to a particular sound rather than simply a loud noise, significantly reducing false activations.

The holder is easy to install, only requires C cell batteries (which last for 12 months) and can be programmed for daily release. Suitable for installation to BS 7273-4 Standard Actuation (Category B).

Other features include a seven segment LED display, manual release button and a low battery warning display.

Ideally suited to environments such as care homes, schools and hospitals where it is essential to have doors in an open position at certain times of the day to aid access, but equally as important to ensure the doors are closed in the event of a fire.

The holder is part of the Agrippa suite of products, which also includes an acoustically triggered fire door closer.

TECHNICAL INFORMATION

Holding force	200 N
Power size	5
Default setting	70dBA, 1.2 - 3.0 kHz
Preferred sounder	Continuous tone *
Dimensions	L-118 x W-102 x D-66
Standard finish	White
Finish	Part number
Standard white	3-80-0060
Polished brass	3-80-0062
Black	3-80-0066

* Not suitable for voice alarm systems

Patented in the United Kingdom under patent number 2507582

Part Number : 3-80-0060

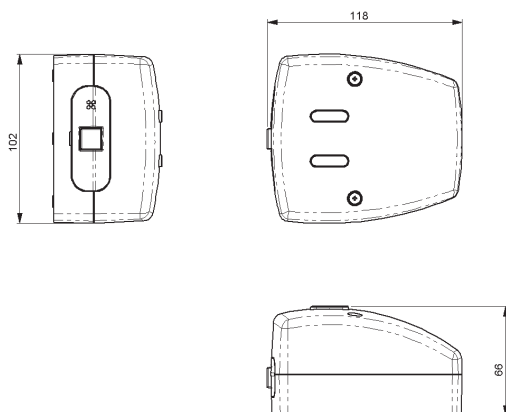

Keeper Plate

