

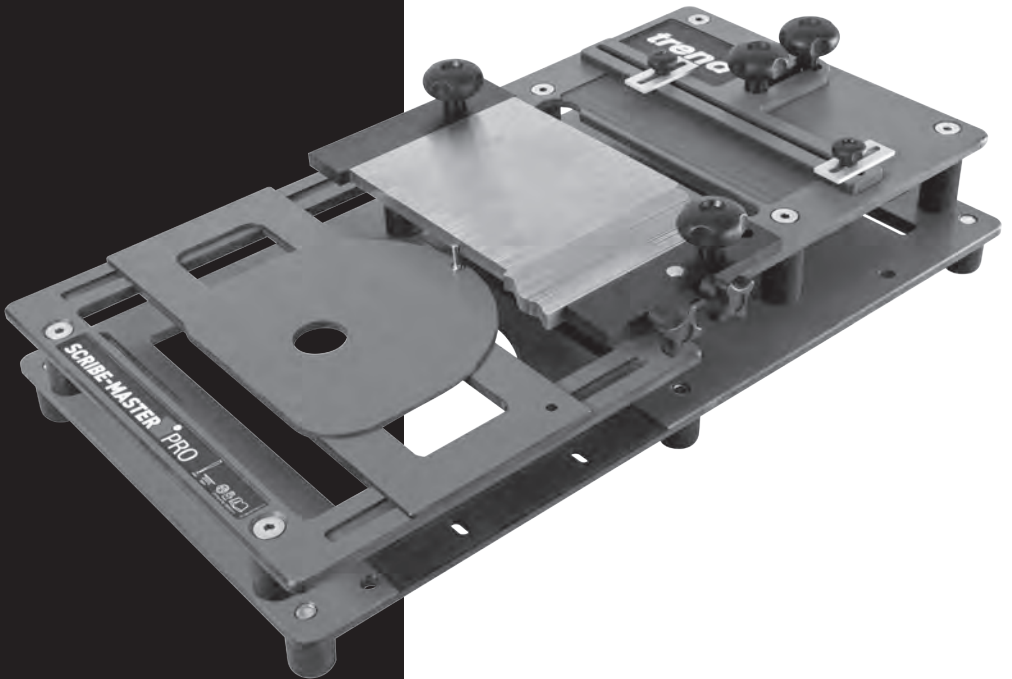

SM/PRO



trend[®]
routing technology



Please read these instructions before use.

Patent No.:
GB2441513

Dear Customer

Thank you for purchasing this Trend product, we hope you enjoy many years of creative and productive use.

Please remember to return your guarantee card within 28 days of purchase.

CONTENTS

TECHNICAL DATA _____	1
SAFETY _____	2-3
ITEMS ENCLOSED _____	4
DESCRIPTION OF PARTS _____	4-5
ACCESSORIES	
– Recommended Cutters _____	6
– Heavy Duty Bag _____	6
– Mounting Kit _____	6
– Tenon Slide Plate _____	6
– Sub-base Set, 30mm Guide Bush _____	6
ASSEMBLY	
– Fitting the Feet _____	7
– Safe Working Practice _____	7
– Router Setup _____	7
– Jig Overview & Setup Position _____	8
– Jig in Cutting Position _____	8
OPERATION	
– Fitting the Spelch Block _____	9
– Setting the Roller Stop Slides _____	9
– Setting the Rear Material Slide _____	9
– Setting Up the Workpiece in the Rear Material Slide _____	10
– Aligning the Rear Material Slide Stops _____	11
– Aligning the Combs & Comb Assembly _____	11
– Moving the Combs to Cutting Position _____	12
– Adding the Workpiece _____	13
– Making the Cut _____	13-14
ACCESSORIES _____	15
MAINTENANCE _____	16
ENVIRONMENTAL PROTECTION _____	16
GUARANTEE _____	16
SPARE PARTS	
– Spare Parts List _____	17
– Spare Parts Diagram _____	18
FREQUENTLY ASKED QUESTIONS _____	19
QUICK START INSTRUCTIONS _____	20

TECHNICAL DATA

Cutter size	4mm Ø x 40mm x 90mm
Guide bush size	30mm
Workpiece	
Max. thickness	32mm
Max. width	195mm
Min. length	300mm
Weight	5.92kg

The following symbols are used throughout this manual:



Denotes risk of personal injury, loss of life or damage to the tool in case of non-observance of the instructions in this manual.



Refer to the instruction manual of your power tool.



Wear Personal Protective Equipment (PPE). Ear, eye and respiratory protection must be worn.

This unit must not be put into service until it has been established that the power tool to be connected to this unit is in compliance with 2006/42/EC (identified by the CE marking on the power tool).

INTENDED USE

This jig is intended to be used with a plunge router fitted with a suitable cutter and 30mm guide bush for professional heavy duty scribing of natural timbers as well as laminate faced chipboards and MDF.

Important Some guide bushes are not perfectly centred and may be slightly smaller or larger than 30mm. Please check your guide bush. Any guide bush that isn't the correct size and not centred will not deliver the best cut. See Ref. UNIBASE.



If you require further safety advice, technical information or spare parts, please call Trend Technical Support or visit www.trend-uk.com

SAFETY



WARNING:

Observe the safety regulations in the instruction manual of the power tool to be used. Please read the following instructions carefully. Failure to do so could lead to serious injury. When using electric tools, basic safety precautions, including the following should always be followed to reduce the risk of fire, electric shock and personal injury. Also observe any applicable additional safety rules. Read the following safety instructions before attempting to operate this product.

PLEASE KEEP THESE INSTRUCTIONS IN A SAFE PLACE.

The attention of UK users is drawn to The Provision and Use of Work Equipment Regulations 1998, and any subsequent amendments.

Users should also read the HSE/HSC Safe Use of Woodworking Machinery Approved Code of Practice and Guidance Document and any amendments.

Users must be competent with woodworking equipment before using our products.

IMPORTANT NOTE:

Residual Risk. Although the safety instructions and operating manuals for our tools contain extensive instructions on safe working with power tools, every power tool involves a certain residual risk which cannot be completely excluded by safety mechanisms. Power tools must therefore always be operated with caution!

General

1. Disconnect power tool and attachment from power supply when not in use, before servicing, when making adjustments and when changing accessories such as cutters. Ensure switch is in "off" position. Always ensure cutter has stopped rotating.
2. Always mount the power tool, accessory or attachment in conformity with the instructions. Only use attachment and accessories specified in the power tool manual. The tool or attachment should not be modified or used for any application other than that for which it was designed. Do not force tool.
3. Keep children and visitors away. Do not let children or visitors touch the tool, accessory or attachment. Keep children and visitors away from work area. Make the workshop child proof with padlock and master switch.
4. Dress properly. Do not wear loose clothing or jewellery, they can be caught in moving parts. Rubber gloves and non-skid footwear is recommended when working outdoors. Wear protective hair

covering to contain long hair.

5. Consider working environment. Do not use the product in the rain or in a damp environment. Keep work area well lit. Do not use power tools near gasoline or flammable liquids. Keep workshop at a comfortable temperature so your hands are not cold. Connect machines that are used in the open via a residual current device (RCD) with an actuation current of 30 mA maximum. Use only extension cables that are approved for outdoor use.
6. The accessory or attachment must be kept level and stable at all times.
7. Keep work area clean. Cluttered workshops and benches can cause injuries. Ensure there is sufficient room to work safely.
8. Secure idle tools. When not in use, tools should be stored in a dry and high or locked up place, out of reach of children.
9. For best control and safety use both hands on the power tool and attachment. Keep both hands away from cutting area. Always wait for the spindle and cutter to stop rotating before making any adjustments.
10. Always keep guards in place and in good working order.
11. Remove any nails, staples and other metal parts from the workpiece.
12. Maintain tools and cutters with care. Keep cutters sharp and clean for better and safer performance. Do not use damaged cutters. Follow instructions for lubricating and changing accessories. Keep handles dry, clean and free from oil and grease.
13. Maintain accessories. Do not use damaged accessories. Only use accessories recommended by the manufacturer.
14. Check damaged parts. Before operation inspect the attachment, the power tool, the cable, extension cable and the plug carefully for signs of damage. Check for alignment of moving parts, binding, breakage, mounting and any other conditions that may effect its operation. Have any damage repaired by an Authorised Service Agent before using the tool or accessory. Protect tools from impact and shock.
15. Do not use tool if switch does not turn it on or off. Have defective switches replaced by an Authorised Service Agent
16. Don't over reach. Keep proper footing and balance at all times. Do not use awkward or uncomfortable hand positions.
17. Don't abuse the cable. Never carry power tool or accessory by cord or pull it to disconnect from the socket. Keep cord from heat, oil and sharp edges. Always trail the power cord away from the work area.
18. Connect dust extraction equipment. If devices are provided for the connection of dust extraction and collection facilities, ensure these are connected and properly used.
19. Check all fixing and fastening nuts, bolts and screws on power tool, attachment and cutting tools before use to ensure they are tight and secure. Periodically check when machining over long periods.
20. Stay alert. Watch what you are doing. Use common sense. Do not operate tools when you are tired, under the influence of drugs or alcohol.
21. Personal Protective Equipment (PPE) for eye, ear and respiratory protection must be worn. All PPE must meet current UK and EU legislation.
22. Do not leave tools running unattended. Do not leave tool until it comes to a complete stop.
23. Always clamp workpiece being machined securely.
24. Only use cutting tools for woodworking that meet EN847-1/2 safety standards, and any subsequent amendments.
25. Vibration levels. Hand held power tools produce different vibration levels. You should always refer to the specifications and relevant Health & Safety Guide.

Routing Safety

1. Read and understand instructions supplied with power tool, attachment and cutter.
2. Keep hands, hair and clothing clear of the cutter.
3. Remove adjusting keys and spanners. Check to see that keys and adjusting spanners are removed from the router tool, cutter and attachment before turning router on. Make sure cutter can rotate freely.
4. Noise. Take appropriate measures for the protection of hearing if the sound pressure of 85dB(A) is exceeded. Routing sound pressure may exceed 85dB(A), so ear protection must be worn.
5. Eye protection. Always wear eye protection in the form of safety goggles, spectacles or visors to protect the eyes.
6. Respiratory protection. Wear a face or dust mask, or powered respirator. Dust masks/filters should be changed regularly.

7. Do not switch router on with the cutter touching the workpiece. At the end of the cut, release the router plunge and allow spindle to stop rotating. Never use the spindle lock as a brake
8. The direction of routing must always be opposite to the cutter's direction of rotation. Do not back-cut or climb-cut.
9. Check before cutting that there are no obstructions in the path of the router. Ensure there are no obstacles beneath workpiece when cutting full thickness, and that a sacrificial work surface is used.

Router Cutter Safety

1. Cutting tools are sharp. Care should be taken when handling them. Do not drop cutters or knock them against hard objects. Handle very small diameter cutters with extra care. Always return cutter to its packaging after use.
2. Always use cutters with a shank diameter corresponding to the size of the collet installed in your tool.
3. The maximum speed (n.max) marked on the tool, or in instructions or on packaging shall not be exceeded. Where stated the speed range shall be adhered to. Recommended speeds are shown in the Trend Routing Catalogue and/or website.
4. Always use router cutters in a router. Drill and boring bits must not be used in a router. Router cutters must only be used for the material cutting application for which they are designed. Do not use on metal or masonry.
5. Never use cutters with a diameter exceeding the maximum diameter indicated in the technical data of the powertool or attachment used.
6. Before each use check that the cutting tool is sharp and free from damage. Do not use the cutting tool if it is dull, broken or cracked or if in any other damage is noticeable or suspected.
7. Cutters should be kept clean. Resin build up should be removed at regular intervals with Resin Cleaner. The use of a PTFE dry lubricant will reduce resin build up. Do not use PTFE spray on plastic parts.
8. When using stacked tooling (multi-blade, block and groover etc.) on a spindle arbor, ensure that the cutting edges are staggered to each other to reduce the cutting impact.
9. Cutter shanks should be inserted into the collet all the way to the line indicated on the shank. This ensures that at least $\frac{3}{4}$ of the shank length is held in the collet. Ensure clamping

surfaces are cleaned to remove dirt, grease, oil and water.

10. Observe the correct assembly and fitting instructions in the router instruction manual for fitting the collet, nut and cutter.
11. Tool and tool bodies shall be clamped in such a way that they will not become loose during operation. Care shall be taken when mounting cutting tools to ensure that the clamping is by the shank of the cutting tool and that the cutting edges are not in contact with each other or with the clamping elements.
12. It is advisable to periodically check the collet and collet nut. A damaged, worn or distorted collet and nut can cause vibration and shank damage. Do not over-tighten the collet nut
13. Do not take deep cuts in one pass; take several shallow or light passes to reduce the side load applied to the cutter and router. Too deep a cut in one pass can stall the router.
14. In case of excessive vibrations whilst using the router stop immediately and have the eccentricity of the router, router cutter and clamping system checked by competent personnel
15. All fastening screws and nuts should be tightened using the appropriate spanner or key and to the torque value provided by the manufacturer.
16. Extension of the spanner or tightening using hammer blows shall not be permitted.
17. Clamping screws shall be tightened according to instructions provided by the manufacture. Where instructions are not provided, clamping screws shall be tightened in sequence from the centre outwards.

Using Routers In A Fixed Position

1. Attention should be made to the HSE's Safe Use of Vertical Spindle Moulding Machines Information Sheet No.18 and any revisions.
2. After work, release the router plunge to protect the cutter.
3. Always use a push-stick or push-block when making any cut less than 300mm in length or when feeding the last 300mm of the cut.
4. The opening around the cutter should be reduced to a minimum using suitably sized insert rings in the table and closing the back fence cheeks or fitting a false fence on the back fence.
5. Whenever possible use a work holding device or jig to secure component being machined. Ensure any attachment is securely fitted to the workbench, with table surface at

approximately hip height.

6. Use a No-Volt Release Switch. Ensure it is fixed securely, easily accessible and used correctly.
7. In router table (inverted) mode, stand to the front right of the table. The cutter will rotate anti-clockwise when viewed from top so the feed direction is from the right (against the rotation of the cutter). In overhead mode, stand to the front left of the machine table and the feed direction is from the left.
8. Do not reach underneath table or put your hands or fingers at any time in the cutting path while tool is connected to a power supply.
9. Never thickness timber between the back of the cutter and the backfence.

Useful Advice When Routing

1. Judge your feed rate by the sound of the motor. Feed the router at a constant feed rate. Too slow a feed rate will result in burning.
2. Trial cuts should be made on waste material before starting any project.
3. When using some attachments e.g. a router table or dovetail jig, a fine height adjuster is recommended.
4. When using a template guide bush, ensure there is sufficient clearance between cutter tip and inside edge of bush and that it cannot come into contact with collet and nut. Ensure cutter and guide bush are concentric.

Router Cutter Repair/Maintenance

1. Repair of tools is only allowed in accordance with the manufacturers instructions.
2. The design of composite (tipped) tools shall not be changed in process of repair. Composite tools shall be repaired by a competent person i.e. a person of training and experience, who has knowledge of the design requirements and understands the levels of safety to be achieved.
3. Repair shall therefore include, e.g. the use of spare parts which are in accordance with the specification of the original parts provided by the manufacturer.
4. Tolerances which ensure correct clamping shall be maintained.
5. Care shall be taken that regrinding of the cutting edge will not cause weakening of the body and the connection of the cutting edge to the body.

Version 7.2 06/2013

ITEMS ENCLOSED

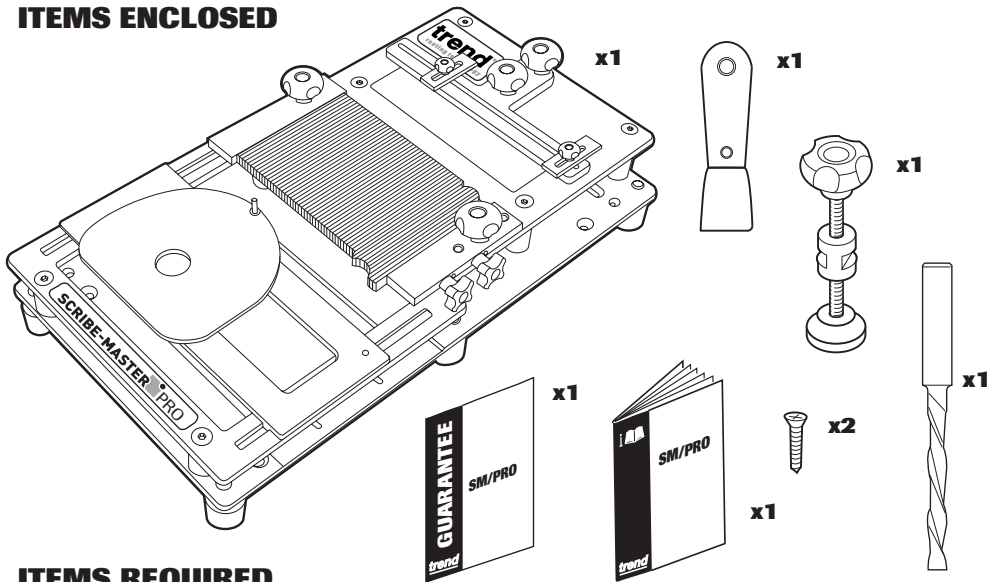

ITEMS REQUIRED

- Plunge router with suitable collet fitted.
- 30mm guide bush.
- Suitable workbench, table or mitre saw stand.
- Pozi[®] No.2 screwdriver.
- Handtools including a try square and sliding bevel.
- Mitre saw.

DESCRIPTION OF PARTS (see next page)

- (A) Main top plate
- (B) Lower top plate
- (C) Base plate
- (D) Rear material slide
- (E) Letterbox slide
- (F) Router base plate
- (G) Router base plate follow pin
- (H) Comb assembly stop end with 3 holes
- (I) Comb assembly stop end with 1 hole
- (J) Material lock down bolt with swivel foot & nut
- (K) Combs
- (L) Comb assembly locating pin
- (M) Comb locking knob
- (N) Comb lockdown knob
- (O) Rear material guide stops
- (P) Rear material slide stop knob
- (Q) Rubber foot
- (R) Rear material slide lock down knob
- (S) Letterbox slide dot mark
- (T) Roller stop slide with knob
- (U) Spelch block fixing screw 5x30mm
- (V) Rubber mounting strip
- (W) Comb alignment tool
- (X) Cutter
- (Y) Spacer (three sizes)
- (Z) Material lock down bolt channel
- (AA) Set out channel

DESCRIPTION OF PARTS DIAGRAM

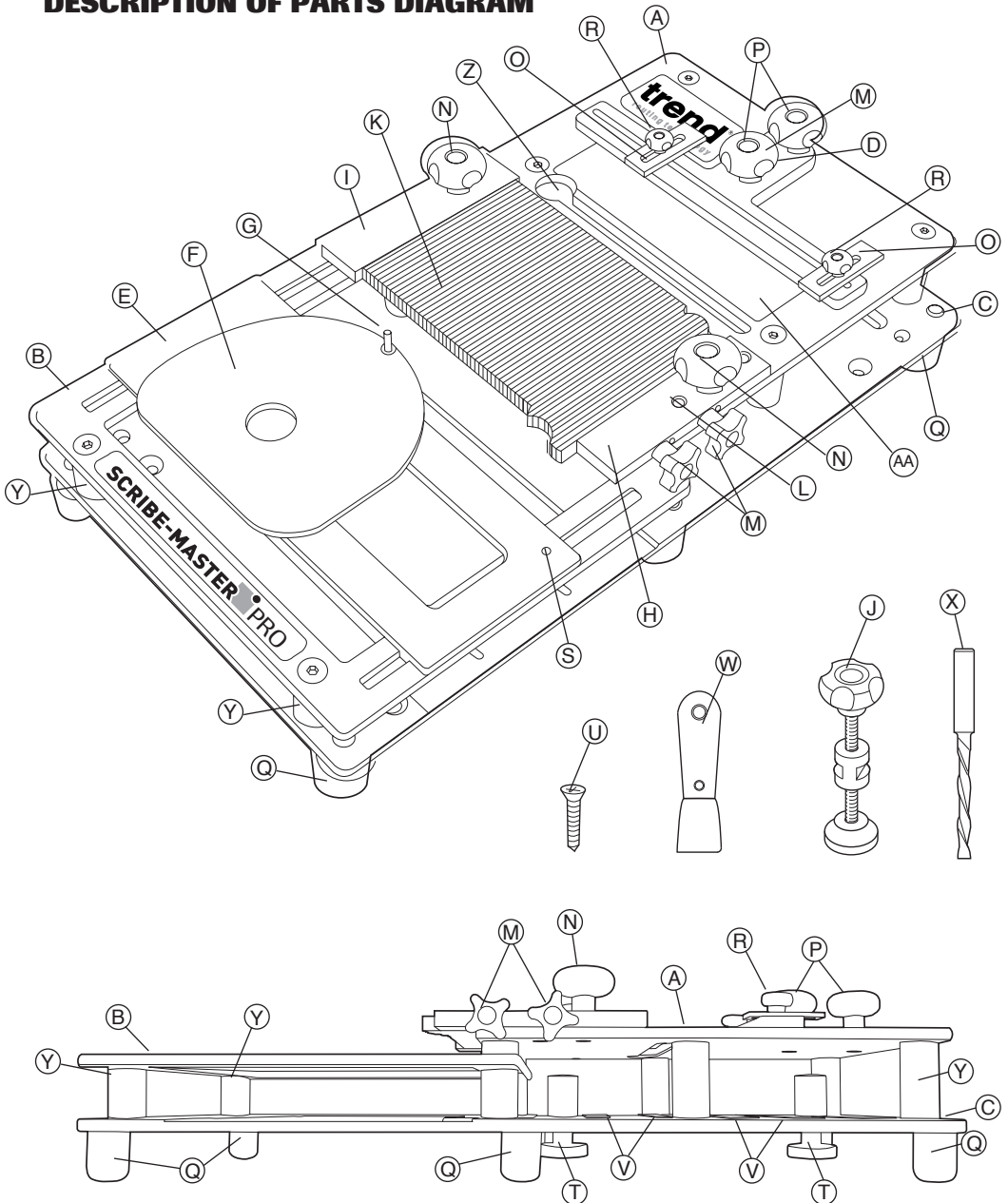

ACCESSORIES

Please use only Trend original accessories.

Recommended Cutters

For softwood and MDF*

Ref. SMC/02X1/4HSS

4mmØ x 40mm cut x 90mm OL

Down cut (Included with jig).



SMC/02X1/4HSS

For hardwood

Ref. SMC/03X8MMHSS

4mmØ x 40mm cut x 90mm OL Down-cut



SMC/03X8MMHSS

Heavy Duty Bag Ref. SM/BP

The carry case is specifically designed for maximum protection and ease of transportation for the Scribe-Master PRO. (Feet need to be removed for transportation).



Chop Saw Stand Mounting Kit Ref. SM/MKP

The bench mount kit is designed to work with a variety of mitre saw stands.

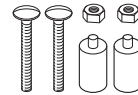

Tenon Slide Plate Ref. SM/TSP

Allows through housings, half lap (halving) and tongue & groove joints to be routed when used with a 30mm guide bush. Maximum cutter diameter 22mm. Maximum working length of 190mm. Maximum tenon length adjustment 50mm.

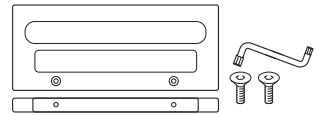

Sub-base Set Ref. UNIBASE

To obtain a perfect accurate close fitting joint, a 30mm guide bush must be used. The guide bush must always be fitted concentric with the cutter. This can be achieved using a Universal Sub-base and 30mm outside diameter guide bush ref. GB30.

The Sub-base fits to the most popular routers and contains screws, a line-up bush and two line up pins. The line up pins and bush ensure exact alignment of with the router spindle.

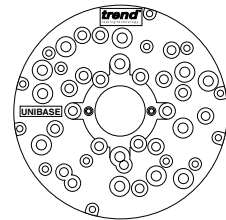

General Instructions for Fitting Sub-bases

1. Fit line up guide bush onto sub-base, with screws supplied.
2. Fit 12.7mm (1/2") shank line up pin into collet of router. Plunge router until pin projects through base and lock plunge.
3. Locate guide bush and sub-base assembly over protruding pin.
4. Line up fixing holes and fit screws. Now tighten up screws.
5. Remove line up bush and line up pin. Alignment should now be correct. Fit 30mm guide bush and cutter.
6. Periodically check the sub-base is concentric to the spindle of the router.

Fits following router models

Atlas Copco OFSE2000 **Bosch** GOF 1300ACE, 1600A, 1700ACE **Casals** FT2000VCE **DeWalt** DW625EK, 629 **Draper** R1900V **Elu** MOF 31, 77, 98, 131, 177(E) **Felisatti** TP246(E), R346EC **Festo** OF2000E **Freud** FT2000E **Hitachi** M12V, M12SA, TR12 **Makita** 3612BR, 3612(C) **Metabo** OF1612, OFE1812 **Performance Pro** CLM1250R >11/2003, CLM2050R **Ryobi** RE600N, R600N, RE601, R500, R502 **Skil** 1875U1 **T-TECH** TT/R127 **Wadkin** R500

30mm Guide Bush

Ref. GB30

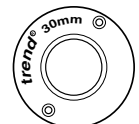

*The abrasive nature of MDF will lead to premature tool wear.

ASSEMBLY

- Check that there is no damage or imperfections on your new jig.
- Check that all the components are enclosed.
- Please recycle all packaging.
- Read all the safety instructions prior to use.

Fitting the Feet

- Stand the jig on its back end and screw on the stand feet.
- We recommend that the feet are attached even if you are attaching the jig to a mitre saw stand using the optional accessory, Ref. SM/MKP. They will protect the roller stop knobs on the underside of the base plate from damage.
- Please recycle all packaging.
- Read all the safety instructions prior to use.



Ensure that all the bolts, knobs and slides are in the correct starting position.

Safe Working Practice

- We recommend that the jig is attached to a chop saw stand using the mitre saw stand mounting kit accessory Ref. SM/MKP.
- The jig can also be used on a table, workmate or workbench but it must be in a stable position.

Router Setup

- Fit a 30mm guide bush to the router. Ensure the guide bush is concentric to the cutter. A sub-base may be required.
- Fit the router cutter into the router following the router machine manufacturer instructions.



Ensure working position is comfortable. Keep proper footing at all times.



Ensure jig is in a stable position before use. Ensure jig is placed at a suitable and comfortable height.



Ensure other end of workpiece is supported properly.

Jig Overview and Setup Position

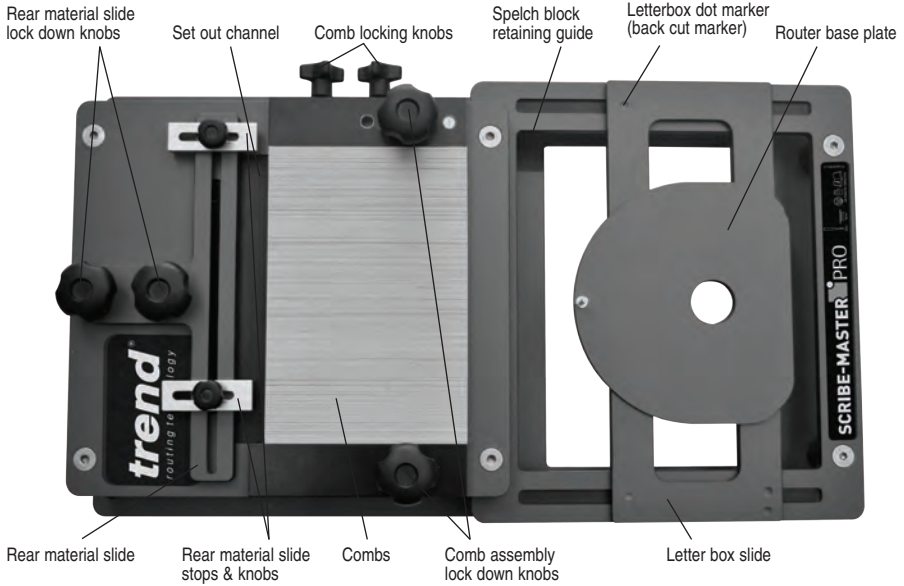

Jig in Cutting Position

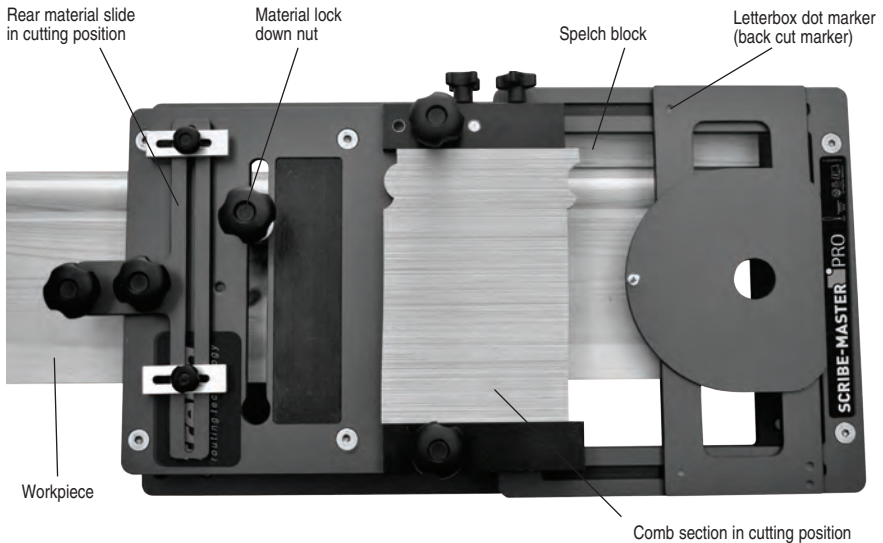

OPERATION



Fitting the Spelch Block



- Prepare a piece of timber 150-170mm x 25-30mm x 50-70mm to become the spelch block.
- Push the spelch block up tight to the spelch block retaining guide.
- Screw securely into place using the 5mm x 30mm screws provided.
- The front edge of the retaining guide lines up with the front edge of the adjacent spacers.
- Check with a straight edge that everything lines up correctly.

Setting the Roller Stop Slides

- Slide the workpiece inbetween the top plate and the base plate.
- Ensure that the most intricate part of the workpiece is pushed up tight against the spacers and spelch block.
- The back face of the workpiece should be against the rubber stripping on the base plate.
- Push the roller stops up tight against the workpiece and lock into place. This allows for easy putting in and retracting of the workpiece.

Setting the Rear Material Slide

- Check that the walls are plumb.
- If the walls are plumb use a sliding square up against the front edge of the rear material slide and lock the rear material slide in a square position using the two knobs.
- If the walls are not plumb use a bevel and set the rear material slide to the correct angle and lock into position.
- Please note that there is a limit to how far out of plumb this jig will work. A lot will depend on the walls and the workpiece. (There is no set degree).



When mould is changed a new spelch block will be required.

Spelch block not yet in position

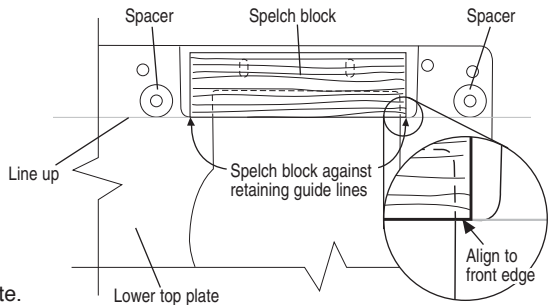
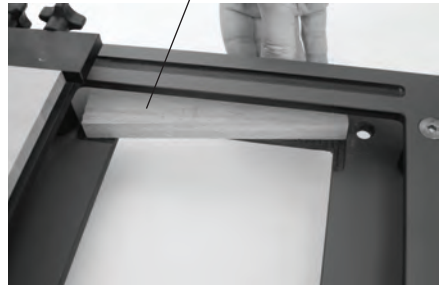

Setting up the Workpiece in the Rear Material Slide

- Cut an off-cut from the workpiece to be scribed. This should be a square cut and of a size the operator feels comfortable with. (We recommend 40-50mm wide).
- Place the workpiece into the set out channel on the top plate ensuring that the most intricate part is pushed up tight against the top edge of the channel.
- The rear face of the workpiece should be pushed up tight against the rear material slide.

Aligning the Rear Material Slide Stops

- One slide stop should be pushed up tightly against the bottom of the off-cut and set flush with the front edge of the off-cut and tightened down.
- The other slide stop should be pushed up against the top of the off-cut. With the front edge flush with the smallest part of the workpiece off-cut and tightened down.
- The slide stops have three functions:
 1. To clamp the workpiece in the right position while the combs are aligned.
 2. To give a smooth run for the follow pin and the corresponding router cut.
 3. To avoid a small radius on the entry and exit cut of the workpiece.
- When the workpiece is a chamfered, bull nosed or pencil round there is no need to use the upper most slide stop. (With these type of mouldings there isn't a flat end cut on the workpiece).



Fit the bottom stop first to ensure off-cut does not move.

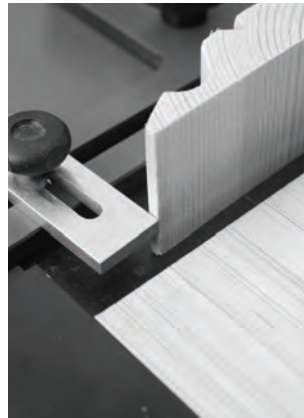

Aligning the Combs and Comb Assembly



- Ensure the comb assembly is in the set-up position. (The comb assembly will underline the words “SET-UP” marked on the top plate).
- The right comb assembly lock down knob should be tightened but the left knob should be left slightly loose, this allows the combs to be tightened.
- Make sure the comb assembly locking knobs are loose prior to setting up combs, (check this by sliding the combs back and forth). Do not completely loosen the comb assembly locking knobs, but just enough to allow the combs to slide.
- Use the comb alignment tool to push the combs up tight against the workpiece ensuring that they fill all the gaps, grooves and slots. Time spent on this procedure will greatly improve the quality of your final cut, so be sure to take your time and be thorough. The jig will shorten your cutting time per scribe by at least 90%, so time spent on getting the set-up correct, is time well spent.
- Once the combs are set, lock them into place using the two locking knobs on the top end of the comb assembly. Do not over tighten, hand tight is more than enough.

The jig is now ready to be moved into the cutting position.



The combs are thin and can be sharp please handle with care.



Do not overtighten comb locking knobs.



Do not slacken the combs off too much as it could distort the profile when retightened.



Take extra care when using the comb alignment tool to prevent slippage and possible injury. Wear gloves.



Moving the Combs to the Cutting Position



- To remove the workpiece off-cut from the rear material slide, loosen the lock down knobs of the rear material slide, and lift out off-cut. Lock back down the knobs to keep secure.
- Remove the comb assembly lock down knobs and turn the comb assembly over. (The pin holes are specific so they cannot be incorrectly located).
- The comb assembly should now underline the word "CUT".
- Replace the two lock down knobs and lock down hand tight.

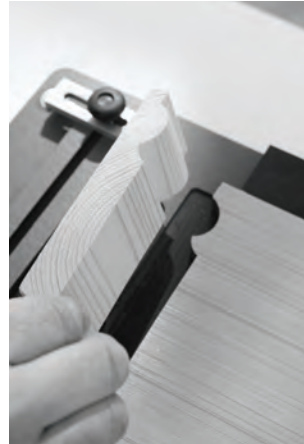

The jig is now set-up to make repeated cuts.



Release plunge on router at end of each cut.



Please note with some smaller routers the cutter may not plunge up inside the base, so extra care must be taken.

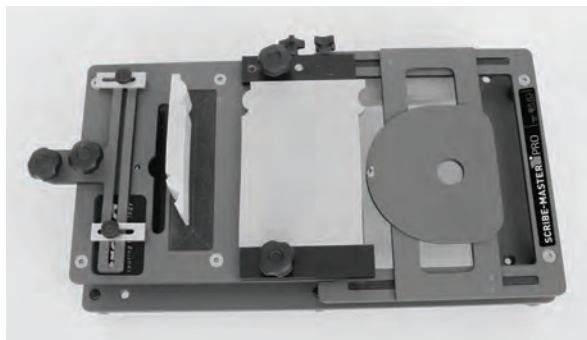

Adding the Workpiece

- Slide the workpiece in between the top plate and the base plate.
- Ensure that the most intricate part of the moulding is touching the spacers (opposite side to the roller stops) and the splench block, with the back of the workpiece touching the base plate rubber strips.
- Ensure that the workpiece is far enough along the jig so that it will be cut by the router and then insert the material lock down nut into its channel and lock down by turning the bolt. Do not over tighten.



Making the Cut 

- Slot the letterbox slide onto the grooves on the lower top plate. Ensure that the slide is the correct way round for the cut. The letterbox slide dot marks should be closest to the combs for right hand scribes. This gives the correct back cut for the scribe.
- If you require a left hand scribe, then you can simply put the workpiece with its front face downwards, with the quirk still positioned against the splench block. Simply rotate the letterbox slide with the letterbox slide dot marks furthest from the combs. This will give a left handed scribe with correct back cut.
- Place the router base plate on top of the letterbox slide in it's correct grooves.
- Ensure that the router base plate and the letterbox slide move freely before placing the router, with guide bush and cutter fitted, into the 30mm hole.

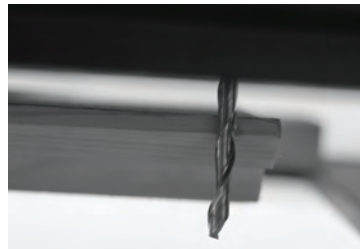

Please note: for dado rails the mould is placed uppermost.



Make trial cuts on waste material before using jig for the actual workpiece.



Ensure other end of workpiece is supported properly.

Right Hand Side

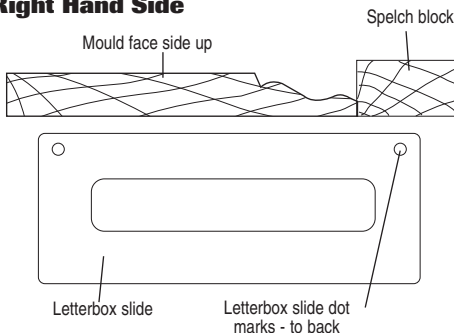

Left Hand Side

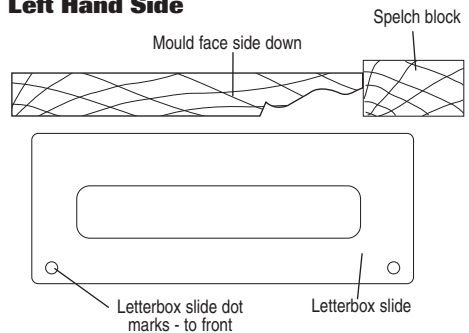

- The router must be set so that the depth of cut clears the bottom of the workpiece by 2mm.
- Move the router baseplate to the left hand side and engage the guide pin against the run in part of the combs (set by the rear material guide stops).
- The router speed should be set to no more than 12,000 rpm.
- After the first pass without a workpiece in the jig, a small cut will be made in the splch block, this will be the exact cut every time the jig is used in this setup. This means that the workpiece can be marked to the correct length and this mark can be aligned with the top of the cut on the splch block, making the jig a one cut solution.
- If a higher speed is selected the cutter will burn the workpiece rather than cut it and will also reduce the cutter life considerably
- Plunge the router to the correct depth and lock down
- Turn on the router and once it has come up to speed move the router from left to right keeping the guide pin in contact with the combs.

Feed direction



Ensure component is clamped securely in the jig before cutting.



There is no need to push hard against the combs with the guide pin, let the router do the work! If you push hard you could distort the cut.

- The cutter will cut according to the comb set-up. Continue to cut all the way to the right hand side and into the sacrificial block.
- Once the scribe is cut, turn off the router and let it stop and release the lock.
- The workpiece can now be removed by loosening the material lock down bolt and sliding the workpiece out of the jig.

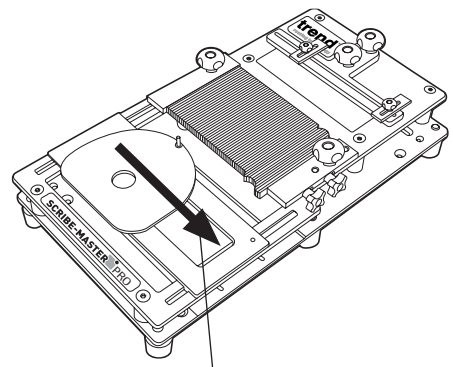

Feed direction

After use, store jig carefully.

ACCESSORIES

Please use only Trend original accessories.

Tenon Slide Plate Accessory 
Ref. SM/TSP

The tenon slide plate allows the jig to be used to cut tenons and trenches when the 30mm guide bush and a suitable size cutter is fitted (cutter not included). The accessory is placed onto the lower top plate, and the clamp bar is placed under the lower top plate and held by two machine screws. The tenon slide plate position can be adjusted, and once set with a try square, it can be locked in place by tightening the two screws with the hex key.



With a 30mm guide bush the maximum size cutter that can be used is 22mm diameter.

After use of the tenon slide plate, loosen the two machine screws, remove the clamp bar and park the clamp bar back on the tenon slide plate with the screws. Store accessory safely.

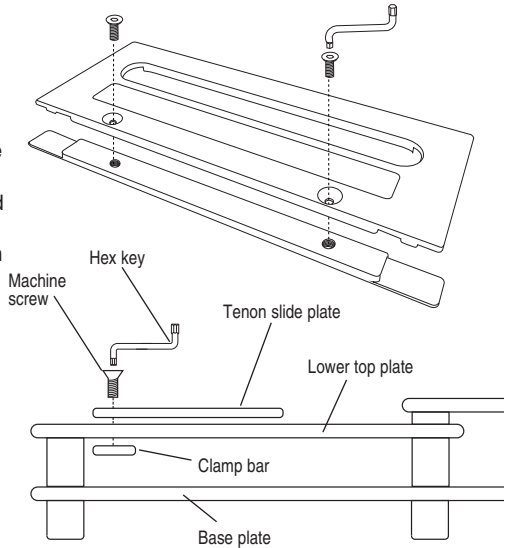

Mounting Kit Accessory 
Ref. SM/MKP

The mounting kit is designed for use with a number of models of mitre saw stands on the market. The kit comprises of four sets of coach bolts, oversize bore washers, nuts and stepped bush. The coach bolts are placed through the slot of the mitre saw mounting brackets from the underside and secured using the nuts. Loosely tighten the nuts to allow adjustment. A second nut is screwed on the coach bolt followed by the stepped bush, which is also threaded to allow for height adjustment. Once the height is set for all four kits, lock the stepped bush in position with the second nut. A 13mm A/F spanner is required (not supplied). The jig has holes and slots in the base plate that will accept the pins on the stepped bracket, adjust the mounting kit position and also the mitre saw mounting brackets positions so that the jig will fit onto all four stepped bush pins. Once set tighten the lower nut with the spanner to secure the coach bolt.

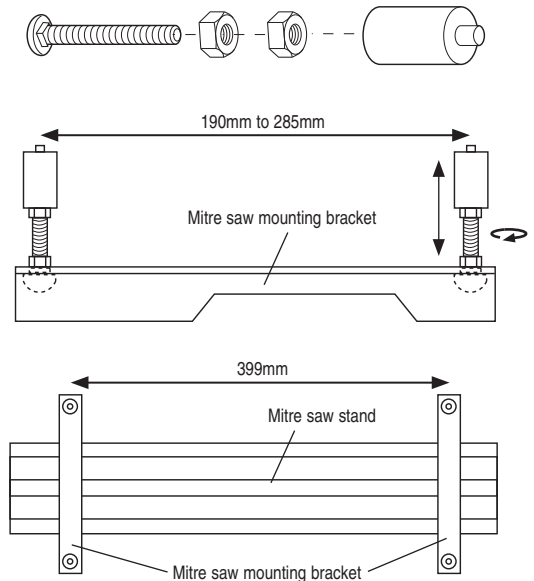

After use either keep the mounting kit fitted to the mitre saw mounting brackets, or remove and store accessory safely.

MAINTENANCE

Please use only Trend original spare parts and accessories.

The jig has been designed to operate over a long period of time with a minimum of maintenance. Continual satisfactory operation depends upon proper tool care and regular cleaning. Keep the jig away from direct moisture.

Cleaning

- Regularly clean the jig with a soft cloth.

Lubrication

- Your jig requires no additional lubrication.
- Do not spray lubricants onto the jig
- Do not use lubricants on the combs.

Storage

- After use, store jig carefully in its packaging.
- Ensure the combs are secure when transporting the jig.
- An accessory case is available Ref. SM/BP.
(Remove the feet before putting in the bag).

ENVIRONMENTAL PROTECTION

Recycle raw materials instead of disposing as waste.

Packaging should be sorted for environmental-friendly recycling.

The product and its accessories at the end of their life should be sorted for environmental friendly recycling.

GUARANTEE

The jig carries a manufacturers guarantee in accordance with the conditions on the enclosed guarantee card.

Please use only Trend original spare parts.

SM/PRO - SPARE PARTS LIST			v2.0 08/2015
No.	Qty.	Desc.	Ref.
1	1	Base Plate	WP-SMP/01
2	1	Lower Top Plate	WP-SMP/02
3	1	Top Plate	WP-SMP/03
4	1	Rear Material Slide	WP-SMP/04
5	1	Letterbox Slide	WP-SMP/05
6	1	Router Base Plate	WP-SMP/06
7	2	Machine Screw Csk M8 x 45mm Socket S/S	WP-SMP/07
8	6	Machine Screw Csk M8 x 65mm Socket S/S	WP-SMP/08
9	1	Locating Pin 10mm	WP-SMP/09
10	2	Nut Square M6 x 5mm	WP-NUT/25
11	2	Rear Material Slide Stop	WP-SMP/11
12	2	Lobe Knob Male M6 x 10mm	WP-SMP/12
13	4	Lobe Knob Male M8 x 16mm	WP-SMP/13
14	1	Follower Pin 4mm	WP-SMP/14
15	6	Foot M12 x 8mm	WP-SMP/15
16	2	Nut Hex Half M8	WP-NUT/16
17	2	Handle Star 40mm	WP-SMP/17
18	6	Plastic Spacer 8mm x 32mm x 25mm	WP-SMP/18
19	2	Plastic Spacer 8mm x 10mm x 25mm	WP-SMP/19
20	4	Plastic Spacer 8mm x 50mm x 25mm	WP-SMP/20
21	1	Comb Assembly Stop End 1 Hole	WP-SMP/21
22	1	Comb Assembly Stop End 3 Hole	WP-SMP/22
23	2	Comb Assembly Stabilizer Bar	WP-SMP/23
24	406	Comb Finger S/S	WP-SMP/24
25	2	Knob Star M5 Female Comb Assembly	WP-SMP/25
26	6	Rubber Grip Strips Self Adhesive	WP-SMP/26
27	1	Lobe Knob M8 & Ball End Cap Assembly	WP-SMP/27
28	1	Comb Alignment Tool	WP-SMP/28
29	2	Screw Wood 5mm x 30mm Csk Pozī [®]	WP-SCW/126
30	1	Comb Assembly Complete	WP-SMP/30
31	1	Cutter 4mm x 40mm x 90mm x 1/4 HSS	SMC/02X1/4HSS
32	1	Manual	MANU/SM/PRO
TENON SLIDE PLATE SM/TSP			
32	1	Tenon Plate	SM/TSP
33	1	Clamp Bar	WP-SMP/33
34	2	Machine Screw Csk M6 x 6mm Socket S/S	WP-SMP/34
35	1	Cranked Short Arm Hex Key 4mm/5mm A/F	WP-SMP/35
MOUNTING KIT SM/MKP			
36	4	Stepped Bush M8 x 58mm x 24.5mm	WP-SMP/36
37	4	Coach Bolt M8 x 60mm	WP-SMP/37
38	8	Nut Hex Full M8	WP-NUT/08
39	8	Washer 10mm	WP-WASH/19

SM/PRO - SPARE PARTS DIAGRAM

v2.0 08/2015

Please use only Trend original spare parts.

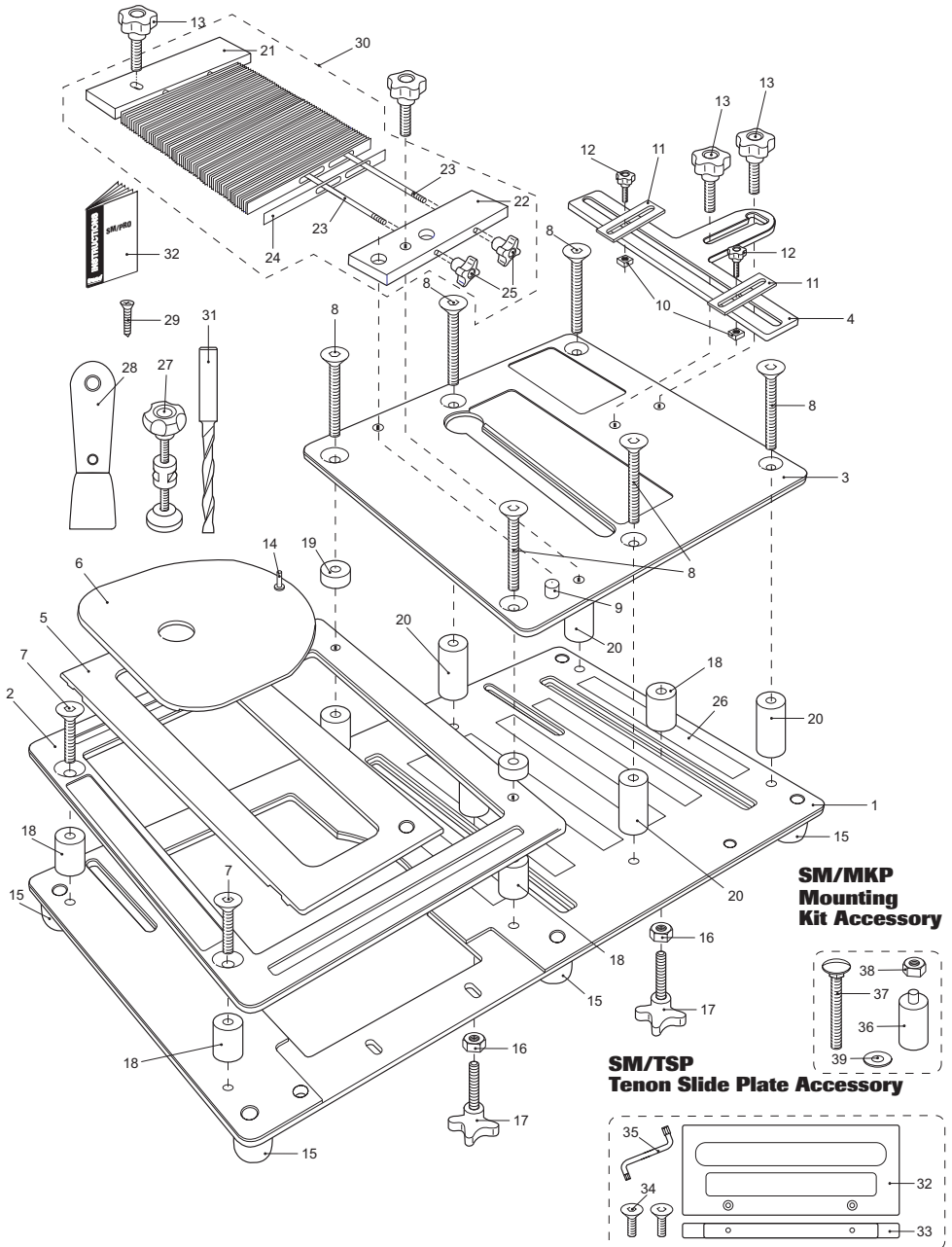

FREQUENTLY ASKED QUESTIONS

Q. Can the jig deal with out of plumb walls?

A. Yes, the jig can be adjusted to cut out of plumb walls.

Q. Can the jig do back cuts to deal with out of square corners?

A. Yes, the jig has a back cut built into its set-up.

Q. Can the jig be mounted onto a chop saw stand?

A. Yes, the jig can be mounted onto most chop saw stands using our mounting accessory kit Ref. SM/MKP.

Q. After cutting, the joint is not accurate and the top edges do not line up?

A. Make sure cutter and guide are correctly aligned. A Ref. Unibase may be required for use with a Ref. GB30 guide bush.

Q. Do combs need to be adjusted?

A. Generally, unless a corner is majorly out of plumb, it is not necessary to adjust combs.

Q. The cutter is central to the guide bush but the joint does not line up at the top?

A. The router may have moved when setting up. Ensure off-cut is tight against channel and the bottom stop is set first.

Q. The combs are tight and do not slide easily?

A. Ensure comb locking knobs have been loosened if still tight. The combs may have been lubricated which has caused binding.

QUICK START INSTRUCTIONS

These instructions are provided for those who are confident with the router and are already familiar with scribing skirting boards on the SM/PRO.

Setting Up

1. Fit 30mm guide bush to router ensuring it is centred.
2. Fit 4mm router cutter.
3. Fit spelch block into jig.
4. Check walls are plumb. If wall square, set rear material slide square. If not, use a sliding bevel to set the angle of the rear material slide correctly.
5. Align rear material slide stops, fitting bottom stop first.
6. Cut work piece offcut using a mitre saw.
7. Place work piece offcut into set out channel recess.
8. Set comb using the comb alignment tool and lock using the comb locking knobs. Do not over tighten knobs.
9. Turn over comb assembly and lock in position. Comb assembly underlines "CUT".
10. Place skirting into jig ensuring mould end is nearest spelch block.
 - (a) Right hand side scribe = mould up.
 - (b) Left hand side scribe = mould down.
11. Clamp work piece in position using roller stops and material lock down clamp.
12. Set letterbox slide on jig.
 - (a) Right hand side scribe = dot marks nearest combs.
 - (b) Left hand side scribe = dot marks furthest from combs.
13. Attach router base plate on letterbox slide.

Routing the Scribe

1. Set cutter depth using router depth stop.
2. Set router speed to no more than 12,000 rpm.
3. Locate guide bush in letterbox slide plate.
4. Switch on router.
5. Plunge down router and rout left to right.
6. Release router plunge.
7. Switch off router.
8. Remove router from letterbox slide plate.
9. Remove skirting board.



Ensure guide bush is concentric to the cutter.



Do not push combs by hand, use comb alignment tool. Do not over-tighten comb locking knobs.

MANU/SM/PRO v2.0



RECYCLABLE

Trend Machinery & Cutting Tools Ltd.

Odhams Trading Estate St Albans Road
Watford WD24 7TR England

Tel: 0044(0)1923 249911

technical@trendm.co.uk

www.trend-uk.com