

<b>D</b>	Originalbetriebsanleitung - Akku-Handkreissäge	6
<b>GB</b>	Original operating manual - Cordless circular saw	16
<b>F</b>	Notice d'utilisation d'origine - Scie circulaire à main sans fil	26
<b>E</b>	Manual de instrucciones original - Sierra circular a batería	37
<b>I</b>	Istruzioni per l'uso originali - Sega circolare a batteria	48
<b>NL</b>	Originele gebruiksaanwijzing - Accu-handcirkelzaag	59
<b>S</b>	Originalbruksanvisning - Batterisänksåg	69
<b>FIN</b>	Alkuperäiset käyttöohjeet - Akkukäsipyörösaha	78
<b>DK</b>	Original brugsanvisning - Akku rundsav	88
<b>N</b>	Originalbruksanvisning - Batteridrevet håndsirkelsag	97
<b>P</b>	Manual de instruções original - Serra circular manual de acumulador	106
<b>RUS</b>	Оригинал Руководства по эксплуатации - Аккумуляторная дисковая пила	117
<b>CZ</b>	Originál návodu k obsluze - Akumulátorová ruční okružní pila	128
<b>PL</b>	Oryginalna instrukcja eksploatacji - Akumulatorowa ręczna pilarka tarczowa	137

## HKC 55 EB

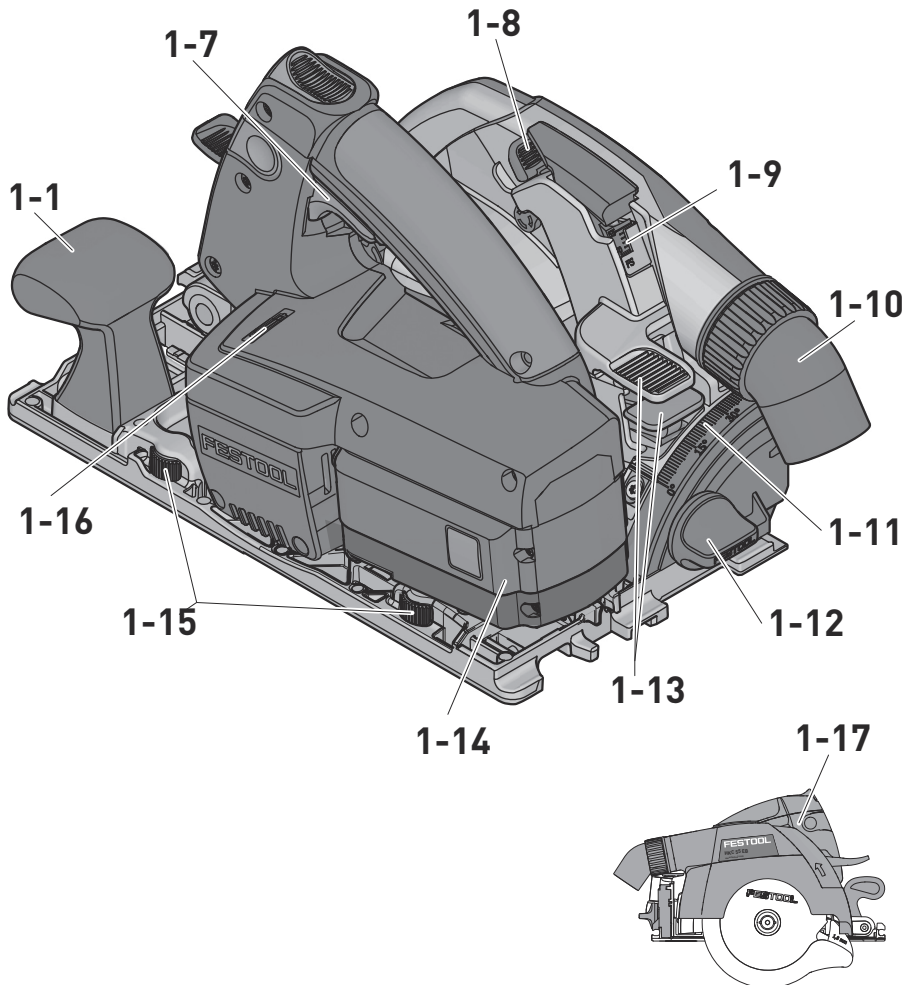

1

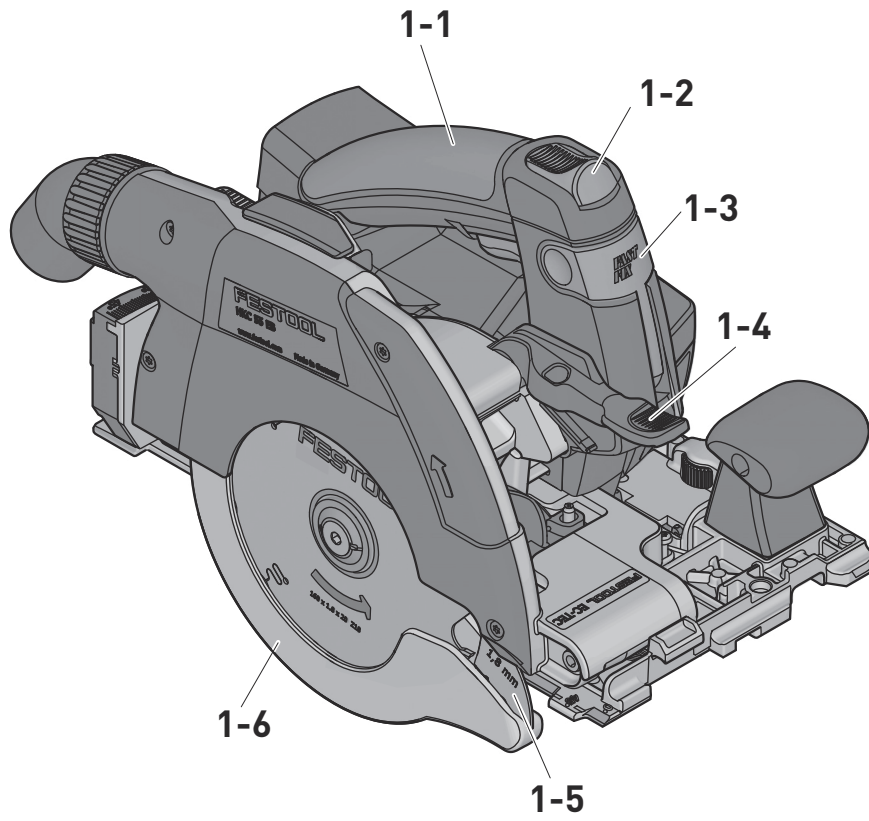

# BPC 18 Li



T18+3, PDC 18, DRC 18, DWC 18, BHC 18,  
TSC 55, HKC 55, PSC 420, PSBC 420,  
KAL



V=

18



Ah

5,2



kg





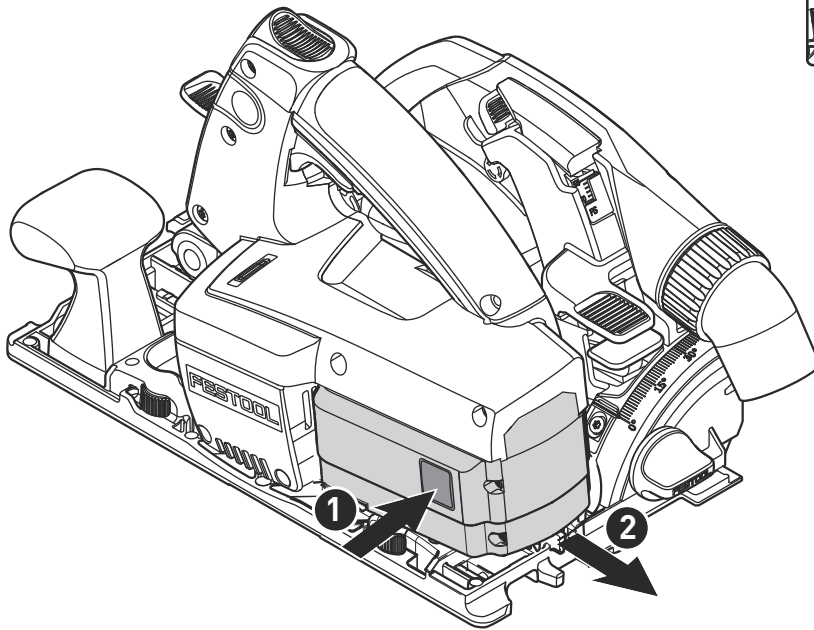
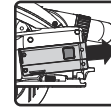

0,68

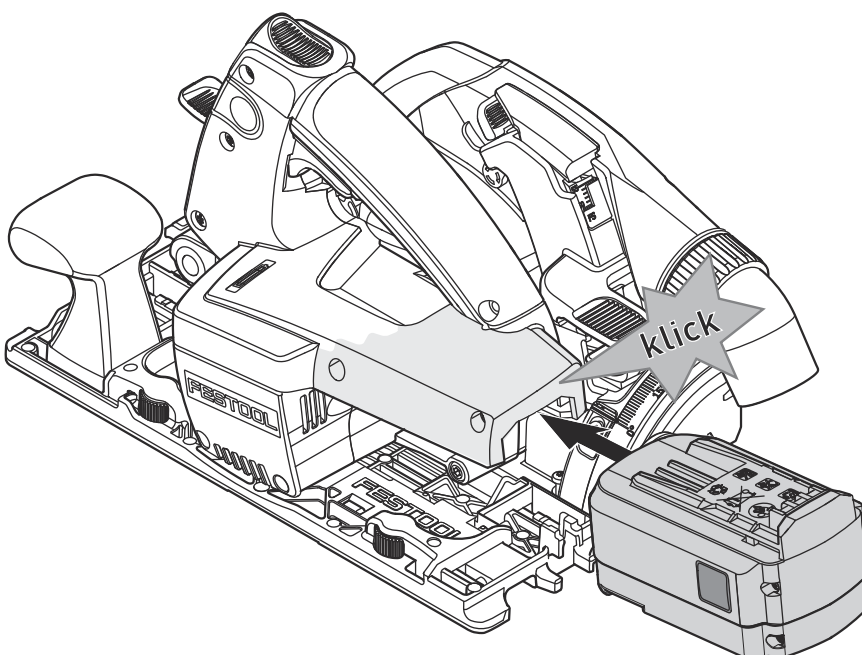
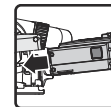
## 2 A



## 2 B



TCL 3		
	V~	220 - 240
	Hz	50/60
	V=	10,8 - 18
	A	3
	C	-5° - 45°
		II
		
Lilon 4,2 Ah	min.	70
Lilon 5,2 Ah	min.	90

**3**

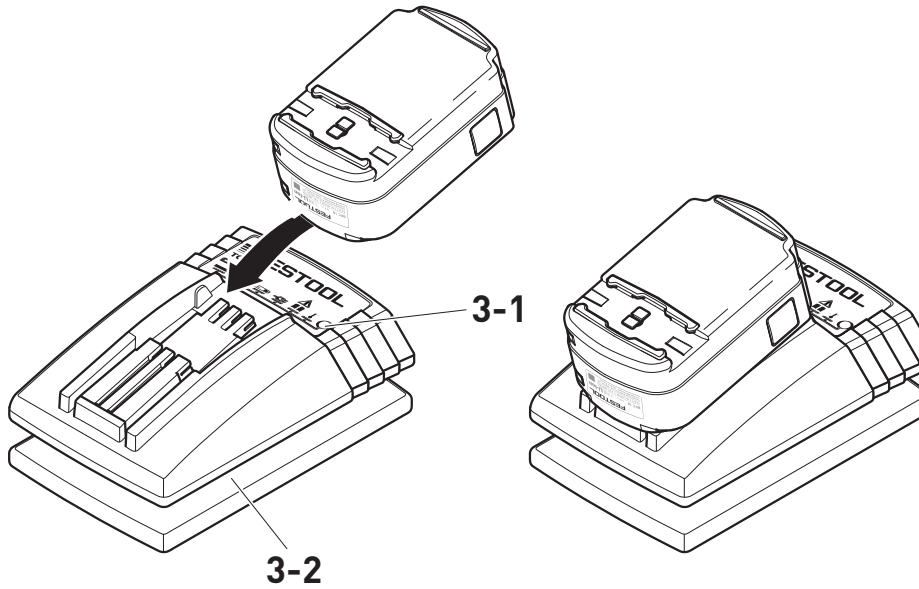

**4**

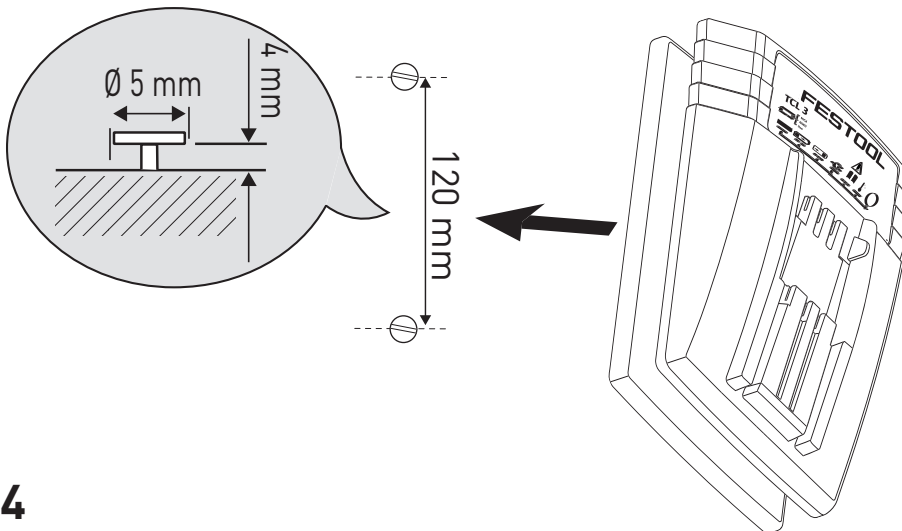

5

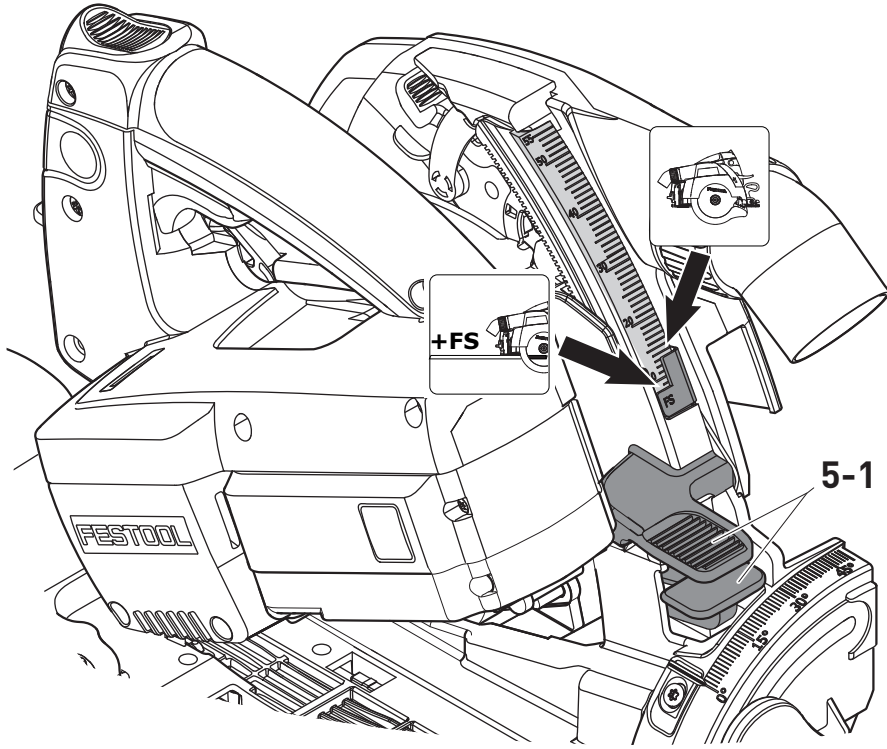

6

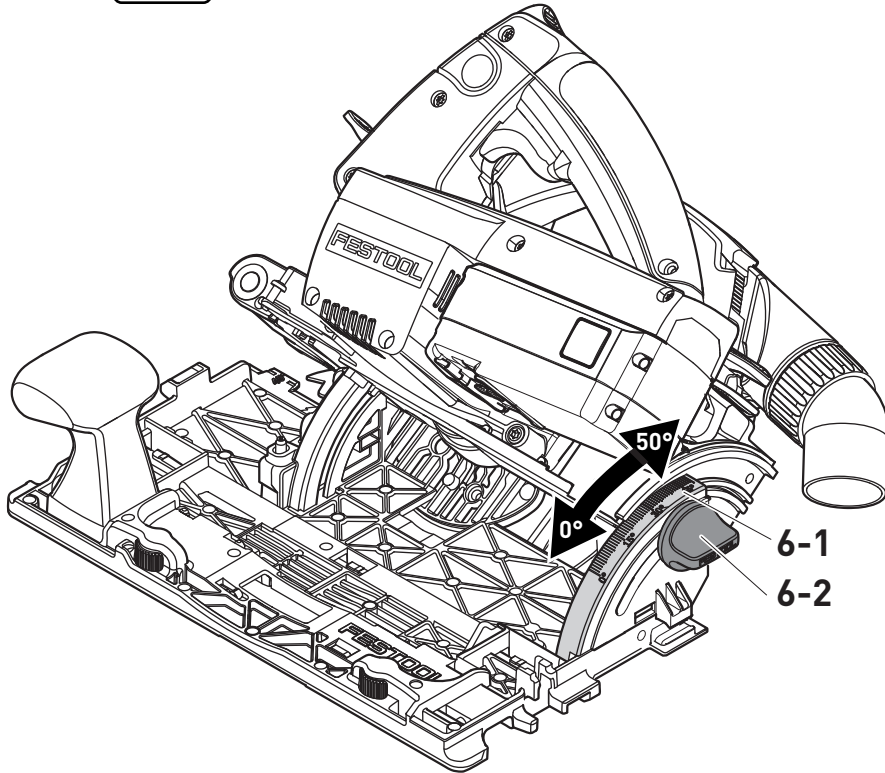















## Original operating manual

1	Symbols.....	16
2	Safety instructions .....	16
3	Intended use .....	19
4	Technical data .....	19
5	Machine features .....	19
6	Operation.....	20
7	Settings .....	20
8	Working with the electric power tool...	22
9	Service and maintenance .....	23
10	Accessories .....	23
11	Environment.....	24
12	Transport.....	24
13	EU Declaration of Conformity.....	25















The illustrations specified are located at the beginning and end of the operating manual.

## 1 Symbols

### Symbol Significance

	Warning of general danger
	Risk of electric shock
	Read operating instructions and safety notices!
	Wear ear protection.
	Wear protective gloves.
	Wear a dust mask.
	Wear protective goggles.
	Do not dispose of as domestic waste.
	Direction of rotation of saw and the saw blade
	Saw blade dimensions a ... Diameter b ... Locating bore
	Tip or advice
	Handling instruction
	Charging times
	Capacity

### Symbol Significance

	Weight
	Mains voltage (input) and frequency
	Voltage (output)
	Rapid charging max.
	Permitted temperature range
	Safety class II
	Inserting the battery pack.
	Removing the battery pack.
	Risk of pinching fingers and hands!
	Hazardous area! Keep hands away!
	Danger of injury by free-moving saw blade
	Circular saw with unprotected saw blade, do not lay down
	pendulum guard open
	pendulum guard closed
	Parking position
	Lay down circular saw with closed pendulum guard only

## 2 Safety instructions

### 2.1 General safety instructions

 **WARNING! Read all safety warnings, instructions, illustrations and specifications provided with this power tool.** Failure to follow all instructions listed below may result in electric shock, fire and/or serious injury.

**Save all warnings and instructions for future reference.**

The term "power tool" in the warnings refers to your mains-operated (corded) power tool or battery-operated (cordless) power tool.

### 2.2 Battery pack and charger safety instructions

- This charger can be operated by persons with reduced physical, sensory or mental capabilities or

a lack of practical experience and knowledge, provided they are supervised or have been instructed to use the machine safely and understand the dangers of machine operation. **Children** are not allowed use or play with the machine.

- Do not open the battery pack or the charger!
- Prevent metal parts (e.g. metal chips) or fluids from entering the charger!
- **Do not use power adapters or battery packs from other manufacturers to operate the cordless power tool. Do not use any charger from other manufacturers for charging the battery pack.** The use of impermissible accessories may result in electric shock and / or serious accidents!
- Protect the battery pack from excessive heat > 50 °C or constant heat sources such as sunlight or naked flames!
- Never use water to extinguish burning li-ion battery packs! Use sand or a fire blanket.
- Protect the machine from moisture.
- Protect the cable from heat, oil and sharp edges.
- Check the plug and the cable regularly and should either become damaged, in order to avoid a hazard, have them replaced by an authorised after-sales service workshop.

### 2.3 Safety instructions for specific circular saws

#### Cutting procedures

- a.  **DANGER! Keep hands away from cutting area and the blade. Keep your second hand on auxiliary handle, or motor housing.** If both hands are holding the saw, they cannot be cut by the blade.
- b. **Do not reach underneath the workpiece.** The guard cannot protect you from the blade below the workpiece.
- c. **Adjust the cutting depth to the thickness of the workpiece.** Less than a full tooth of the blade teeth should be visible below the workpiece.
- d. **Never hold the workpiece in your hands or across your leg while cutting. Secure the workpiece to a stable platform.** It is important to support the work properly to minimize body exposure, blade binding, or loss of control.
- e. **Hold the power tool by insulated gripping surfaces, when performing an operation where the cutting tool may contact hidden wiring.** Contact with a "live" wire will also make exposed metal parts of the power tool "live" and could give the

operator an electric shock.

- f. **When ripping, always use a rip fence or straight edge guide.** This improves the accuracy of cut and reduces the chance of blade binding.
- g. **Always use blades with correct size and shape (diamond versus round) of arbour holes.** Blades that do not match the mounting hardware of the saw will run off-centre, causing loss of control.
- h. **Never use damaged or incorrect blade washers or bolt.** The blade washers and bolt were specially designed for your saw, for optimum performance and safety of operation.



i. Wear suitable protective equipment such as ear protection, safety goggles, a dust mask for work which generates dust, and protective gloves when working with raw materials and when changing tools.

#### Kickbacks causes and related warnings

- kickback is a sudden reaction to a pinched, jammed or misaligned saw blade, causing an uncontrolled saw to lift up and out of the workpiece toward the operator;
- when the blade is pinched or jammed tightly by the kerf closing down, the blade stalls and the motor reaction drives the unit rapidly back toward the operator;
- if the blade becomes twisted or misaligned in the cut, the teeth at the back edge of the blade can dig into the top surface of the wood causing the blade to climb out of the kerf and jump back toward the operator.

Kickback is the result of saw misuse and/or incorrect operating procedures or conditions and can be avoided by taking proper precautions as given below.

- a. **Maintain a firm grip with both hands on the saw and position your arms to resist kickback forces. Position your body to either side of the blade, but not in line with the blade.** Kickback could cause the saw to jump backwards, but kickback forces can be controlled by the operator, if proper precautions are taken.
- b. **When blade is binding, or when interrupting a cut for any reason, release the trigger and hold the saw motionless in the material until the blade comes to a complete stop. Never attempt to remove the saw from the work or pull the saw backward while the blade is in motion or kickback may occur.** Investigate and take corrective actions to eliminate the cause of blade binding.
- c. **When restarting a saw in the workpiece, centre**

**the saw blade in the kerf so that the saw teeth are not engaged into the material.** If a saw blade binds, it may walk up or kickback from the workpiece as the saw is restarted.

- d. **Support large panels to minimise the risk of blade pinching and kickback.** Large panels tend to sag under their own weight. Supports must be placed under the panel on both sides, near the line of cut and near the edge of the panel.
- e. **Do not use dull or damaged blades.** Unsharpened or improperly set blades produce narrow kerf causing excessive friction, blade binding and kickback.
- f. **Blade depth and bevel adjusting locking levers must be tight and secure before making the cut.** If blade adjustment shifts while cutting, it may cause binding and kickback.
- g. **Use extra caution when sawing into existing walls or other blind areas.** The protruding blade may cut objects that can cause kickback.

#### Function of the lower guard

- a. **Before using the machine, check whether the lower guard closes correctly. Do not use the saw if the lower guard does not move freely or close immediately. Never clamp or secure the lower guard in an open position.** If the saw is dropped or accidentally falls to the ground, the lower guard may become bent. Open the guard using the retraction lever and make sure that the guard can move freely and does not make contact with the saw blade or other components at every cutting angle and depth.
- b. **Check the function of the springs for the lower guard. If the lower guard or springs show any signs of a defect, have the saw serviced before using it again.** Damaged parts, sticky deposits or accumulated chips may result in delayed operation of the lower guard.
- c. **Open the lower guard by hand only for special cuts, such as plunge cuts and angled cuts. Open the lower guard using the retractor lever and release it as soon as the saw blade plunges into the workpiece.** The lower guard should work automatically for all other sawing work.
- d. **Make sure the lower guard is covering the saw blade before placing the saw on a worktop or on the ground.** An unprotected, rotating saw blade placed on any surface will move the saw against the cutting direction and cut anything in its path. Therefore, always make sure the saw blade has stopped rotating.

#### Function of the guide wedge [1-5]

- a. **Use the correct saw blade for the guide wedge,**

**where possible. The function of the guide wedge is restricted if using saw blades with a thicker blade core.** To ensure that the guide wedge functions properly, make sure the blade core of the saw blade is thinner than the guide wedge and that the tooth width is greater than the thickness of the guide wedge. Expect increased risk of kickback when using a thicker saw blade.

- b. **Do not operate the saw if the guide wedge is bent.** Even the slightest problem can cause the guard to close more slowly.

#### Further safety instructions

- **This electric power tool cannot be installed in a work bench.** The electric power tool may become unsafe and cause serious accidents if installed in benches from other manufacturers or self-manufactured work benches.
- **Never place your hands into the chip ejector.** You may injure yourself on rotating parts.
- **Use suitable detectors to determine if utility lines are hidden in the work area or call the local utility company for assistance.** Contact with electric lines can lead to fire and electric shock. Damaging a gas line can lead to explosion. Penetrating a water line causes property damage or may cause an electric shock.
- **Wait until the power tool stops completely until placing it down.** The tool can become entangled and lead to a loss of control of the power tool.
- Do not use the machine for overhead work.
- **Harmful/toxic dust may be produced during your work (e.g. paint containing lead, certain types of wood and metal).** Inhaling or coming into contact with this dust may represent a hazard for operating personnel or persons in the vicinity. Comply with the safety regulations that apply in your country.



Wear a P2 dust mask to protect your health.

#### 2.4 Residual risks

In spite of compliance with all relevant design regulations, hazards while operating the machine still occur e.g.:

- Touching the saw blade in the area of the front opening below the saw table,
- Touching the parts of the saw blade that protrude below the saw table while cutting,
- Touching rotating parts from left and right sides: saw blade, clamping flange, flange screw.,
- Kickback of machine due to jamming in the workpiece,



- Touching live parts when the casing is opened and the mains plug is in the socket,
- the flying off of parts,
- the flying off of machine parts from a damaged machine,
- noise emission,
- dust emission.

### 2.5 Aluminium processing



When sawing aluminium, the following measures must be taken for safety reasons:

- Connect the machine to a suitable dust extractor.
- Regularly remove dust deposits from the motor housing.
- Use an aluminium saw blade.
- Close the viewing window/chipguard.



Wear protective goggles.

- When sawing panels, they must be lubricated with paraffin but thin-walled profiles (up to 3 mm) can be sawed without lubrication.

### 2.6 Emission levels

Levels determined in accordance with EN 60745 are typically:

Sound pressure level	$L_{PA} = 79 \text{ dB(A)}$
Noise level	$L_{WA} = 90 \text{ dB(A)}$
Measuring uncertainty allowance	$K = 3 \text{ dB}$



### CAUTION

#### Operating noise

#### Damage to hearing

- Use ear protection!

Vibration emission value  $a_h$  (vector sum for three directions) and uncertainty K measured in accordance with EN 60745:

#### Vibration emission level (3 directions)

Cutting wood	$a_h < 2.5 \text{ m/s}^2$
Cutting metal	$a_h = 3.0 \text{ m/s}^2$
Uncertainty	$K = 3 \text{ m/s}^2$

The specified emission values (vibration, noise)

- are used to compare machines.
- They are also used for making preliminary estimates regarding vibration and noise loads during operation.

- They represent the primary applications of the power tool.

Increase possible for other applications, with other insertion tools or if not maintained adequately. Take note of idling and downtimes of machine!

### 3 Intended use

- Cordless circular saws are suitable for sawing
- wooden materials and wood-based materials,
  - plaster- and cement-bonded fibres,
  - plastic materials,
  - aluminium (only with a special saw blade for aluminium offered by Festool)

Only saw blades with the following specifications can be used: saw blade diameter 160 mm; recommended cutting width 1,8 mm, max. 2.2 mm with restricted function of guide wedge; locating bore 20 mm; recommended steel blade thickness 1,5 mm, max. 1.8 mm; suitable for speeds up to 6800 rpm. Never use sanding discs in the machine.

The machine is designed and approved for use by trained persons or specialists only.

**Charger TCL 3** suitable for

- charging Festool battery packs: BP, BPS and BPC (NiMH, NiCd, li-ion are recognised automatically.)
- indoor use only.



The user is liable for improper or non-intended use.

### 4 Technical data

Cordless circular saw	HKC 55 EB
Motor voltage	14,4 - 18 V
No-load speed	4500 rpm
Inclination	0° to 50°
Cutting depth at 0°	0 - 55 mm
Cutting depth at 50°	38 mm
Saw blade dimensions	
recommended	160 x 1,8 x 20 mm
max.	160 x 2,2 x 20 mm
Weight without battery pack	3,4 kg

① Further technical data on the charger and the supplied battery pack can be found in images [2] and [3].

### 5 Machine features

- [1-1] Handles
- [1-2] Switch-on lock
- [1-3] Lever for changing blades

- [1-4] Retractor lever for pendulum guard
- [1-5] Guide wedge
- [1-6] Pendulum guard
- [1-7] On/Off switch
- [1-8] Lever for plunge function
- [1-9] Split scale for cutting depth stop (with/without guide rail)
- [1-10] Extractor connector
- [1-11] Angle scale
- [1-12] Knob for angle setting
- [1-13] Cutting depth adjuster
- [1-14] Battery pack
- [1-15] Adjustable jaws
- [1-16] Capacity display
- [1-17] Insulated gripping surfaces (grey shaded area)
- [4] Wall mount for charger

## 6 Operation

### 6.1 Changing the battery pack

- ⓘ The battery pack is delivered partially charged. Charge the battery pack completely before using for the first time.

#### Removing the battery pack [2 A]

#### Inserting the battery pack [2 B]

### 6.2 Capacity display

The capacity display [1-16] automatically displays the charge state of the battery pack [1-7] when the ON/OFF switch is actuated:

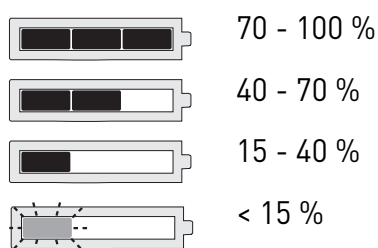

**Recommendation:** Charge battery pack before further use.

### 6.3 Festool charger

#### Charging the battery pack [3]

The LED [3-1] on the charger indicates the respective operating status of the charger.

- LED yellow - lit continuously**  
Charger is ready to use.
- LED green - flashing quickly**  
Charging battery pack at maximum rate.

- LED green - flashing slowly**  
Charging battery pack with reduced current, begins at 90% battery level.

- LED green - lit continuously**  
Charging process is complete or will not resume because the current battery level is above 90%.

- LED red - flashing**  
General fault indication, e.g. incomplete contact, short circuit, defective battery pack, etc.

- LED red - lit continuously**  
Battery temperature is outside the permitted range.

#### Charger cable holder [3-2]

- Unwind the cable completely from the recess before using the charger.

## 7 Settings

**WARNING**

**Risk of injury**

► Always disconnect the battery pack before performing any type of work on the machine!

### 7.1 Electronics

#### Smooth start-up

The electronically controlled smooth start-up ensures that the machine starts up jolt-free.

#### Constant speed

The motor speed remains constant through electronic control to ensure a uniform cutting speed even when under load.

#### Current limiting

Current limiting prevents excessive current consumption under extreme overload, which can lead to a decrease in the motor speed. The motor immediately restarts after the load is removed.

#### Brake

The HKC 55 EB is fitted with an electronic brake. When the saw is switched off, the saw blade slows to a stop electronically within approx. 2 seconds.

#### Restart protection

The integral restart protection prevents the electric power tool from automatically starting up again after an interruption in power when the ON/OFF switch is pressed. In this case the electric power

tool must be switched off and then switched back on again.

### Temperature cut-out

When exceeding a certain engine temperature level, the machine power supply and speed are capped. The power tool continues operating at reduced power to allow the ventilator to cool the motor rapidly. The power tool resumes to full performance automatically once the motor has cooled sufficiently.

### 7.2 Adjusting the cutting depth

The cutting depth can be set at 0 – 55 mm.

- ▶ Press cutting depth adjustment **[5-1]**.
- ▶ Pull up or push down saw at main handle.



Cutting depth without guide rail/cross cutting guide rail

max. 55 mm



Cutting depth with guide rail/cross cutting guide rail

max. 51 mm

### 7.3 Adjusting the cutting angle

- ① The saw table must be on an even surface when adjusting the cutting angle.

**between 0° and 50°:**

- ▶ Open knob **[6-2]**.
- ▶ Swivel sawing unit to the desired cutting angle **[6-1]**.
- ▶ Close knob **[6-2]**.
- ① Both positions (0° and 50°) are set at the factory and can be readjusted by the after-sales service team.
- ① For angled cuts, the cutting depth is smaller than the value displayed on the cutting depth scale.

### 7.4 Adjust pendulum guard



**Risk of injury! Sharp edges!** The pendulum guard swings back quickly in the event of sudden release.

The pendulum guard **[1-6]** must only be opened with the retractor lever **[1-4]**.

### 7.5 Changing the saw blade



## WARNING

#### Risk of injury

- ▶ Always disconnect the battery pack before performing any type of work on the machine!



## CAUTION

#### Hot and sharp tools

#### Risk of injury

- ▶ Do not use insert tools that are blunt or defective.
- ▶ Wear protective gloves.
- ▶ Swivel saw to 0° position before replacing the saw blade and set maximum cutting depth.
- ▶ Position saw on motor cover when replacing **[7-1]**.
- ▶ Turn lever **[7-4]** as far as stop.
- ▶ Open the screw **[7-8]** using the Allen key **[7-3]**.
- ▶ Hold the pendulum guard open **[7-7]** only with retractor lever **[7-5]**.
- ▶ Remove saw blade **[7-9]**.
- ▶ Insert new saw blade.
- ▶  The direction of rotation of the saw blade **[7-10]** and saw **[7-6]** must match.
- ▶ Insert the outer flange **[7-11]** so that the pin engages in the recess on the inner flange.
- ▶ Release retractor lever **[7-5]** and allow the pendulum guard to swivel back **[7-7]** to its final position.
- ▶ Tighten screw **[7-8]**.
- ▶ Reposition lever **[7-4]**.

### 7.6 Dust extraction



## WARNING

#### Dust hazard

- ▶ Dust can be hazardous to health. Always work with a dust extractor.
- ▶ Always read applicable national regulations before extracting hazardous dust.

#### Independent extraction

- ▶ Secure the connection piece **[8-2]** of the dust collection bag **[8-3]** at the extractor connector with a clockwise rotation **[8-1]**.
- ▶ To empty remove the connection piece **[8-2]** of the dust collection bag **[8-3]** from the extractor connector with an anti-clockwise rotation **[8-1]**.

#### Festool mobile dust extractor

A Festool mobile dust extractor with an extractor hose diameter of 27 mm or 36 mm (36 mm is recommended due to the reduced risk of clogging) is connected to the extractor connector at the elbow **[1-10]**.

- Static charge may occur if an anti-static suction hose is not used. The user may suffer an electric shock.

## 8 Working with the electric power tool



Please observe all mentioned safety informations and the following rules when working:

- Only guide the machine against the workpiece when it is switched on.
- Check the function of the pendulum guard prior to use and do not use the electric power tool if it does not slide in and out easily.
- Always secure the workpiece in such a manner that it cannot move while being processed.
- Always hold the machine with two hands at the handles [1-1] when performing work. This reduces the risk of injury and is a prerequisite for precise work.
- Always push the saw forwards [10-9], and never towards yourself.
- Adapt the infeed speed to prevent the cutters on the saw blade from overheating and prevent plastic materials from melting during cutting.
- Make sure that the knob [1-12] is tightened before starting work.

### 8.1 Switch on/off

- ▶ Slide switch-on lock [1-2] upwards.
- ▶ Press the ON/OFF switch [1-7].

Press = ON

Release = OFF

### 8.2 Acoustic warning signal

Acoustic warning signals sound and the machine switches off in the following operating states:



Battery low or machine overloaded:

peep

- ▶ Change the battery
- ▶ Reduce the machine load

### 8.3 Sawing along the scribe mark

The cut indicators display the cutting sequence without a guide rail:

0° cuts: [9-1]

45° cuts: [9-2]

### 8.4 Cutting sections

Position the saw with the front part of the saw table on the workpiece, switch on saw and push forward in cutting direction.

## 8.5 Sawing cut-outs (plunge cuts)



In order to avoid kickbacks, the following instructions must be observed without fail when plunge cutting:

- Always position saw with the rear edge of the saw table against a fixed stop.
- When working with the guide rail, place the saw against the kickback stop FS-RSP (accessories) [10-6] clamped to the guide rail.



### Caution! Danger of crushing!

Always keep a firm grip on the machine with your free hand when adjusting plunge cuts. Never position your fingers behind or below the saw blade.

### Procedure

- ▶ Adjusting cutting depth, **see section 7.2.**
- ▶ Press lever [10-1] down.  
*Sawing unit swivels upwards to plunge-cut position.*
- ▶ Hold retractor lever [10-2] downwards as far as stop.  
*Pendulum guard [10-4] opens and the saw blade is exposed.*
- ▶ Position saw on workpiece and position against a stop (kickback stop).
- ▶ Switch on saw.
- ▶ Slowly press down saw to the set cutting depth until the saw engages, release retractor lever [10-2] and push forward in cutting direction [10-9].

*The notch [10-3] indicates the absolute rear cutting point of the saw blade (Ø 160 mm) when using the saw at maximum cutting depth with the guide rail.*

## 9 Service and maintenance



### WARNING

#### Risk of injury, electric shock

- ▶ Always disconnect the battery pack from the machine before any cleaning or maintenance!
- ▶ All maintenance and repair work which requires the motor housing to be opened, must only be carried out by an authorised service workshop.



**Customer service and repair** only through manufacturer or service workshops: Please find the nearest address at: [www.festool.com/service](http://www.festool.com/service)



Only use original Festool spare parts!  
Order No. at: [www.festool.com/service](http://www.festool.com/service)



Regular cleaning of the machine, above all the adjustment devices and the guides, is an important safety factor.

### Observe the following instructions:

- ▶ To ensure constant air circulation, always keep the cooling openings in the housing unobstructed and air accessible.
- ▶ Use an extractor on all openings of the power tool to remove chips and splinters.
- ▶ The pendulum guard must always be able to move freely and close independently. Always keep the area around the pendulum guard clean. Clear from dust and chippings by blowing out with compressed air or using a brush.
- ▶ Keep the contacts on the machine, charger and battery pack clean.

### Information on battery packs

- Store in a cool, dry place at a temperature between 5 °C and 25 °C.
- Protect battery packs from moisture, water and heat.
- Do not leave empty battery packs in a charger disconnected from the mains power supply for longer than one month. Danger of deep discharge!
- If you intend to store li-ion battery packs for longer periods without use, you should charge them to 40 % capacity (approx. 15 min charging time).

## 10 Accessories

The order numbers of the accessories and tools can be found in the Festool catalogue or on the Internet under "[www.festool.com](http://www.festool.com)".

In addition to the accessories described, Festool also provides a comprehensive range of system accessories that allow you to use your saw more effectively and in diverse applications, e.g.:

- Parallel stop, extension table PA-HKC 55
- Kickback stop FS-RSP
- Parallel stop FS-PA and guide extension FS-PA-VL
- Side-mounted cover, false joint ABSA-TS 55

### 10.1 Saw blades, other accessories

In order to saw different materials quickly and cleanly, Festool offers saw blades for all applications that are specially designed for your Festool portable circular saw.

### 10.2 Guide rail

The guide rail enables you to make clean, accurate cuts while simultaneously protecting the surface of the workpiece from damage.

In conjunction with the extensive range of accessories, exact angled cuts, mitre cuts and fitting work can be completed with the guide system. The option of attaching the guide rail securely using clamps [10-7] ensures safer working conditions.

- ▶ Adjust the guide play between the saw table and the guide rail using the two adjustable jaws [10-8].

### The splinterguard [10-5] requires breaking in before first usage:

- ▶ Position saw at the very end of the guide rail, so that the guide plate is level.
- ▶ Swivel saw to 0° position and set to maximum cutting depth.
- ▶ Switch on saw.
- ▶ Slowly push saw along the entire length of the rail.

*The edge of the splinterguard now corresponds exactly to the cutting edge.*

### 10.3 Cross cutting guide rail

The cross cutting guide rail's intended use is sawing wood and panel materials.

It allows precise and clean cuts, especially angled cuts can be carried out easily and a high repeat accuracy. The saw retreats automatically into the initial position.

- ① The splinterguard must be broken in before first use, **see chap. 10.2**.



**Every time before use, check that the cross cutting guide rail is retracted correctly** and have it repaired, if necessary. Never use if automatic retraction is not operating correctly.

### Connect saw to the cross cutting guide rail

- ▶ Slide saw onto the cross cutting guide rail in sawing direction.

*The saw engages in the sliding block [11-2].*

*The quick fastener [11-1] locks in behind the saw table.*

*The saw is securely connected to the cross cutting guide rail.*

### Loosen saw from the cross cutting guide rail.

- ▶ Push saw forward slightly in sawing direction.
- ▶ Turn quick fastener [11-1] to the front.
- ▶ Remove saw towards the rear against the sawing direction.

### Cutting with the compound mitre saw

- ▶ Open knob at adjustable stop [12-2].
- ▶ Adjust angle at the scale [12-4].
- ▶ Close knob at adjustable stop [12-2].
- ▶ Adjust depth and angle of the saw, **see ch. 7.2 and 7.3.**

- ▶ The saw's play on the cross cutting guide rails can be set with the two setting jaws [12-3].



*The saw must slide easily across the rail.*

- ▶ Place the adjustable stop [12-2] and the fixed stop against the work piece and position the cross cutting guide rail.

- ▶ Switch saw on.

- ▶ Push saw in direction of cutting.

*Pendulum guard opens. Sawing commences.*

**WARNING**

**Protruding rotating saw blade**

**Risk of injury**

- ▶ Do not position hands near cutting area and saw blade.
- ▶ Do not place hands below the work piece.
- ▶ Do not hold the workpiece in hand or place it on your leg.

- ▶ After cutting, switch off saw.
- ▶ Pull back saw into initial position.
- ▶ Remove cross cutting guide rail from work piece.



**Warning! Danger of injury! Saw blade exposed, do not lay down!** If the saw or the pendulum guard does not retreat to initial position, interrupt sawing process and check functionality, possibly remove jammed woodchips.





**Parking position - pendulum guard closed!** In parking position the saw can be laid down with the cross cutting guide rail.

## 11 Environment

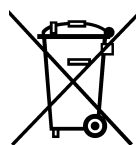

**Do not dispose of the device in household waste!** Recycle devices, accessories and packaging. Observe applicable national regulations.

**EU only:** In accordance with European Directive on waste electrical and electronic equipment and implementation in national law, used electric power tools must be collected separately and handed in for environmentally friendly recycling.

**Return used or faulty battery packs** to your local specialist retailer, Festool after-sales service or nearest public waste management facility (observe applicable regulations). Batteries must be discharged on return. Battery packs will then be recycled.

**EU only:** In accordance with the European Directive on batteries and implementation in national law, defective or used battery packs/batteries must be collected separately and handed in for environmentally friendly recycling.

**Information on REACH:** [www.festool.com/reach](http://www.festool.com/reach)

## 12 Transport

The lithium-ion batteries are subject to the requirements of the legislation on hazardous goods. A lithium battery pack alone falls below the applicable limit value and certified as per UN manual ST/SG/AC.10/11/rev. 3 part III, subsection 38.3. However, dangerous goods regulations may apply when several battery packs are transported. For shipping by third parties (e.g. air transport or freight forwarding company) special requirements with regard to packaging and labelling must be observed. For the preparation of the package an expert on hazardous goods must be consulted. Please observe any further national regulations.

Only return the battery pack if the housing is undamaged. Tape over the exposed contacts and wrap the battery pack so that it cannot move inside the packaging.

## 13 EU Declaration of Conformity

Cordless circular saw	Serial no.
HKC 55 EB	10012134
Year of CE mark: 2014	

We declare under sole responsibility that this product complies with all the relevant requirements in the following directives, standards and normative documents:

2006/42/EC, 2004/108/EC (until 19.04.2016), 2014/30/EU (from 20.04.2016), 2011/65/EU, EN 60745-1:2009, EN 60745-2-5:2010, EN 55014-1:2006+ A2:2011, EN 55014-2:1997+ Corrigendum 1997+ A1:2001+ A2:2008.

Charger	Serial no.
TCL 3	10002345, 10004911
Year of CE mark: 2012	

We declare under sole responsibility that this product complies with all the relevant requirements in the following directives, standards and normative documents:

2004/108/EC (until 19.04.2016), 2014/30/EU (from 20.04.2016), 2006/95/EC (until 19.04.2016), 2014/35/EU (from 20.04.2016), 2011/65/EU, EN 60335-1:2012, EN 60335-2-29:2004+ A2:2010, EN 55014-1:2006+ A2:2011, EN 55014-2:1997+ Corrigendum 1997+ A1:2001+ A2:2008, EN 61000-3-2:2006+ A1:2009+ A2:2009, EN 61000-3-3:2013.

### **Festool GmbH**

Wertstr. 20, D-73240 Wendlingen, Germany



Wolfgang Zondler

Head of Research, Development and Technical Documentation

2015-07-01