

# YardMaster

THE ORIGINAL No. 1

**Please Direct Enquires to:**

Yardmaster International  
Cahore Rd  
Draperstown  
BT45 7AP  
Tel: 028 796 28449  
Email: info@yardmaster.co.uk

**Bitte alle Anfragen an:**

I.N.I.  
Kaistraße 7-9  
40221 Düsseldorf  
Tel: 02505 / 939987  
Email: service@yardmaster.co.uk

**Demandes De Reseiignements A:**

Trigano Jardin  
Service Commercial  
Usine du Boulay  
41170 Cormenon  
Mondoubleau  
Tel: (02) 54 73 55 55  
Fax: 02 54 73 55 61  
Email: Sav.Amca@Trigano.Fr

YARDMASTER  
MODEL 1017  
GARAGE

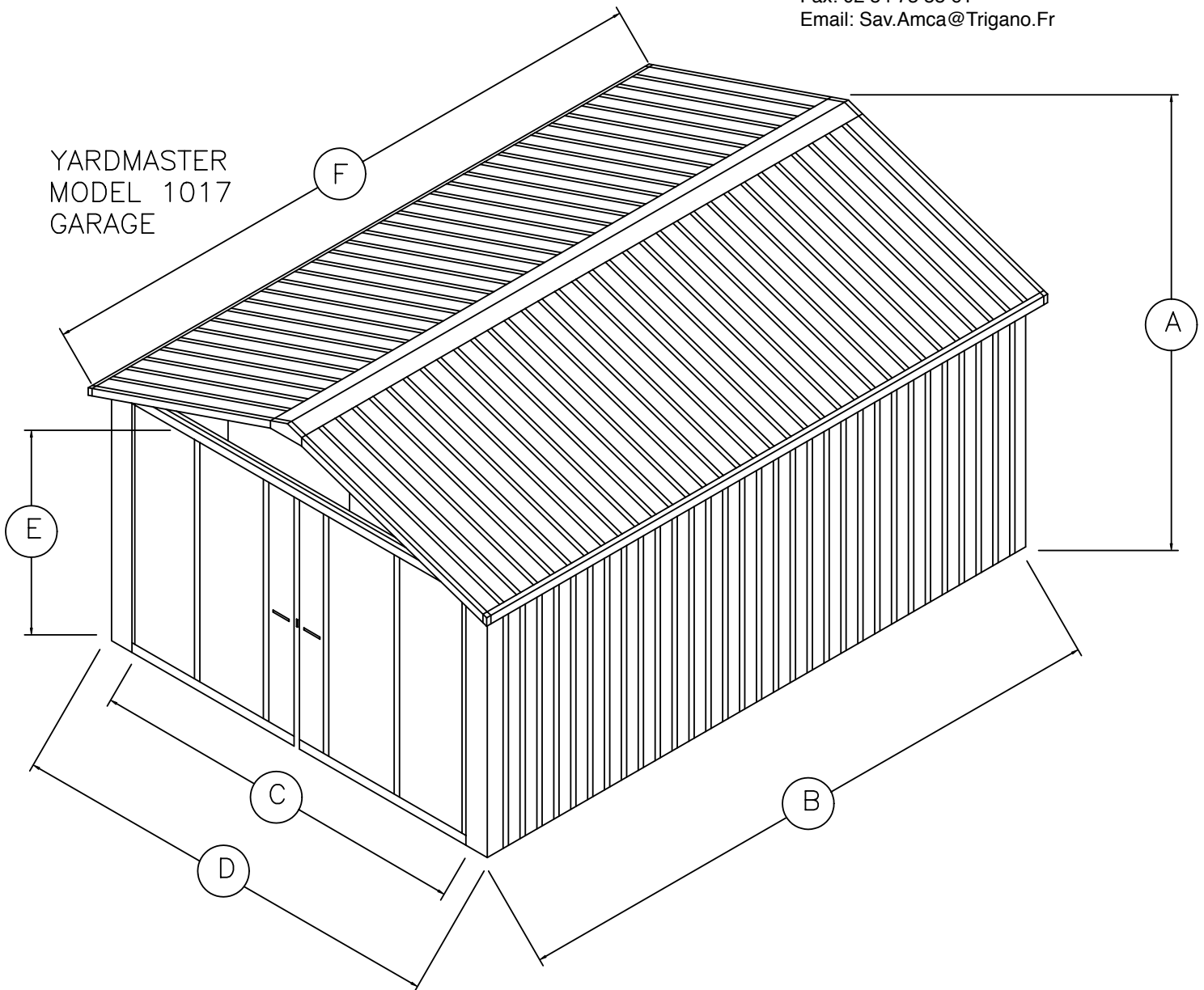

A	B	C	D	E	F	B X D
2.21m	5m	2.57m	2.8m	1.76m	5.17m	14m <sup>2</sup>

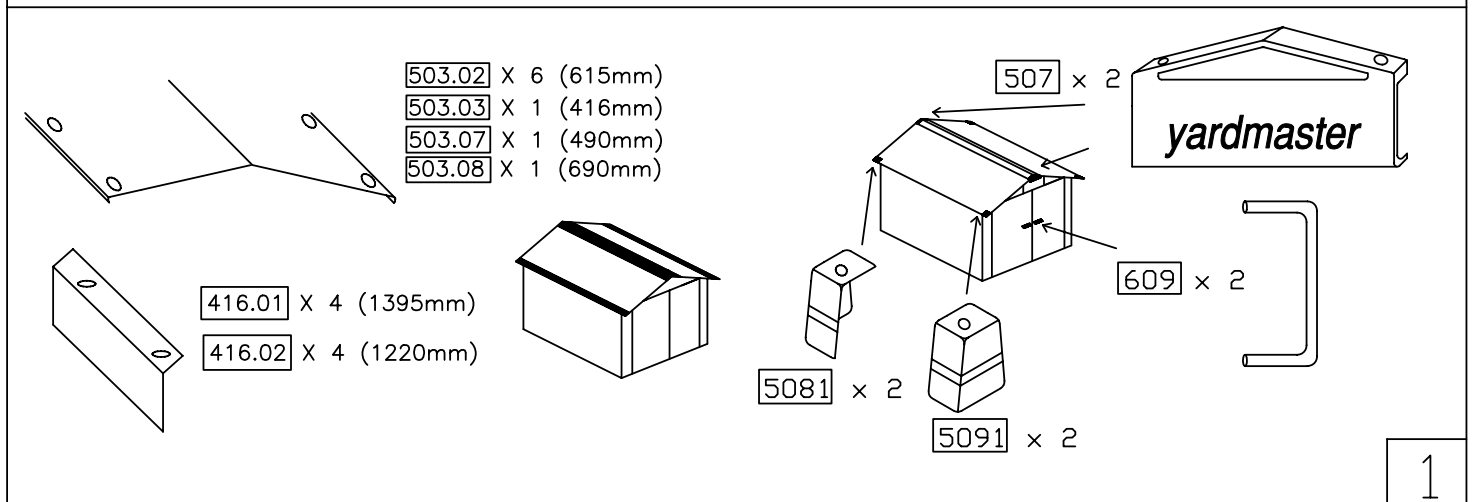
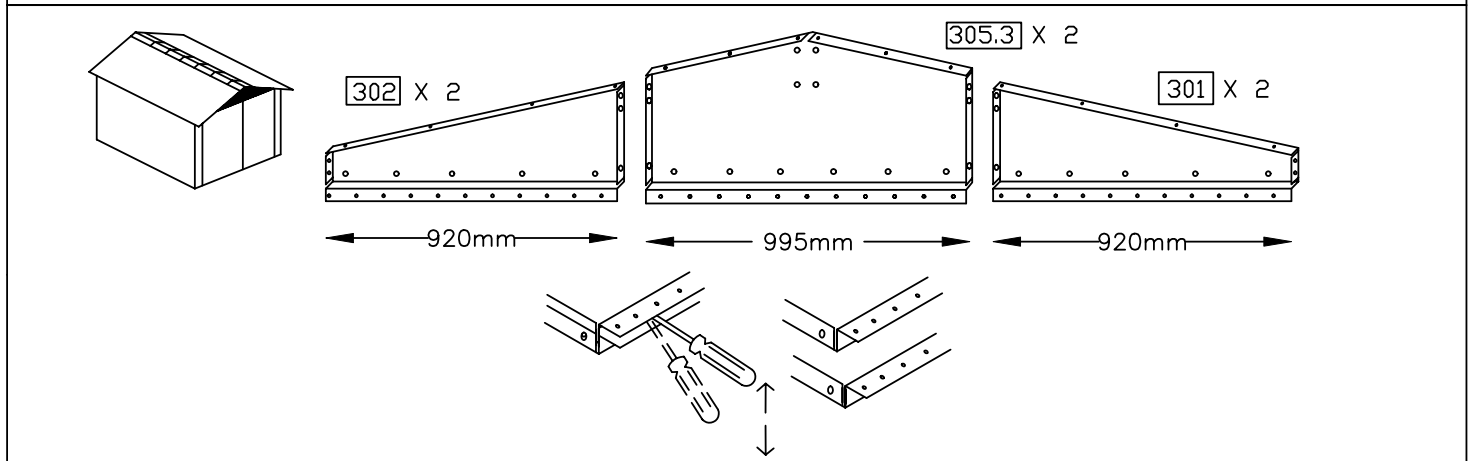
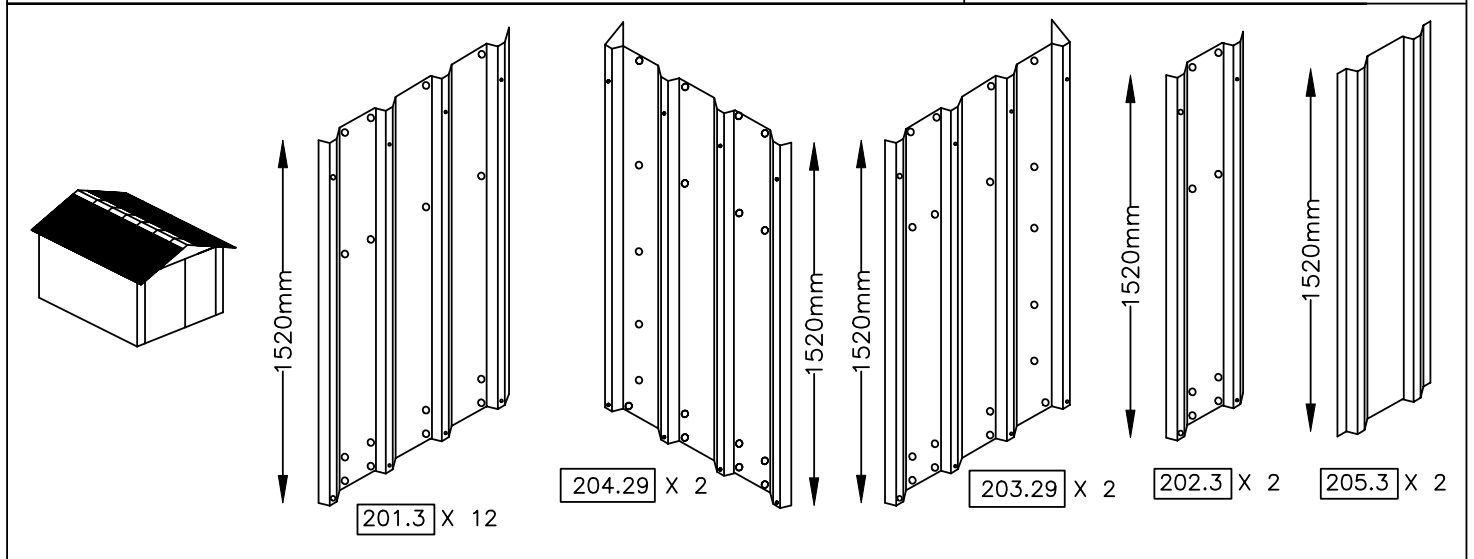
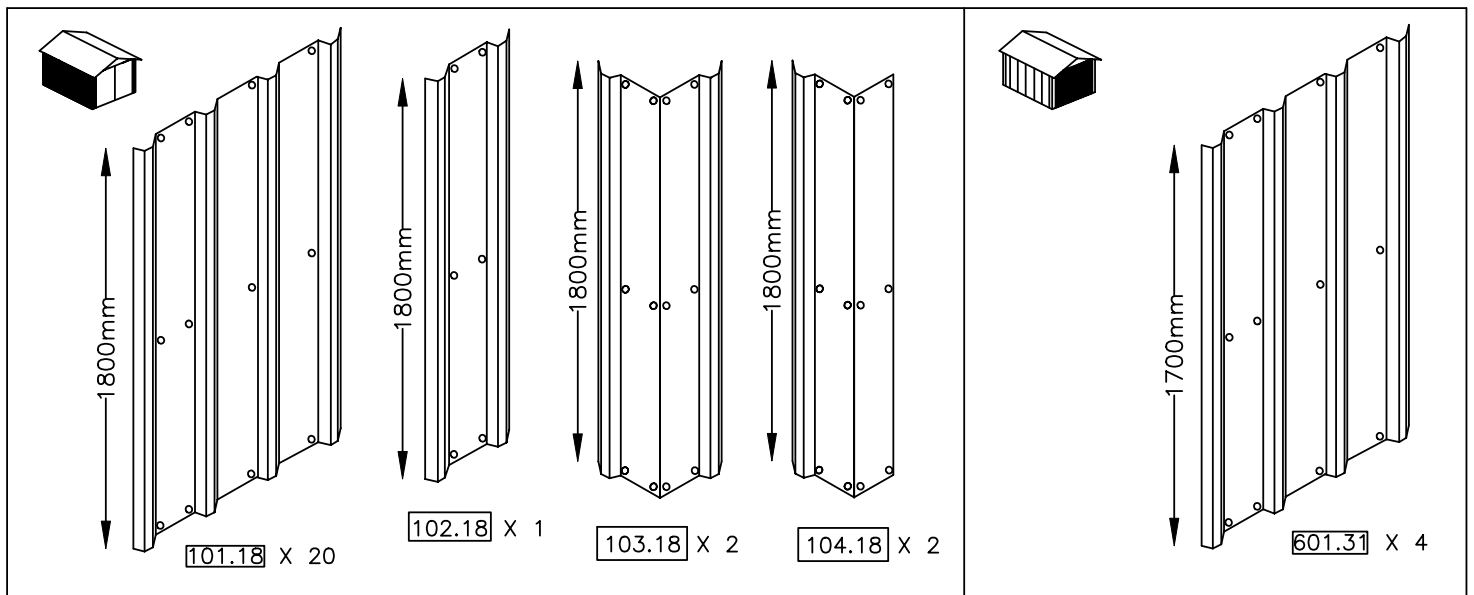

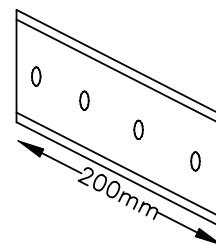
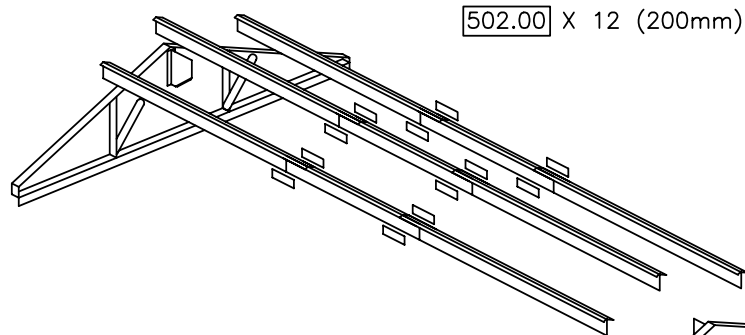
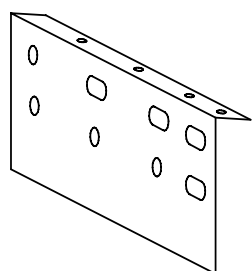
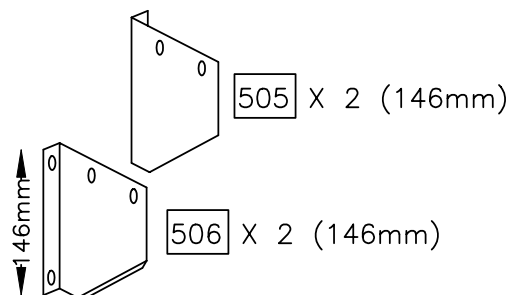
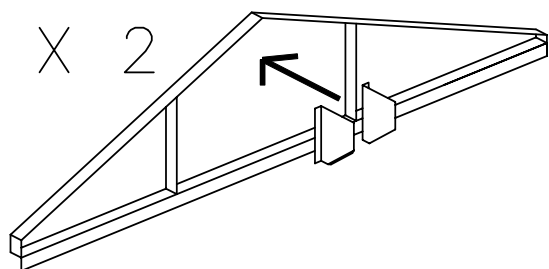
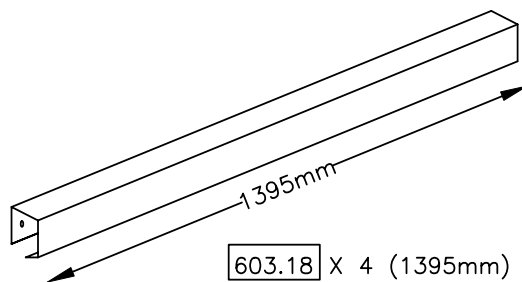
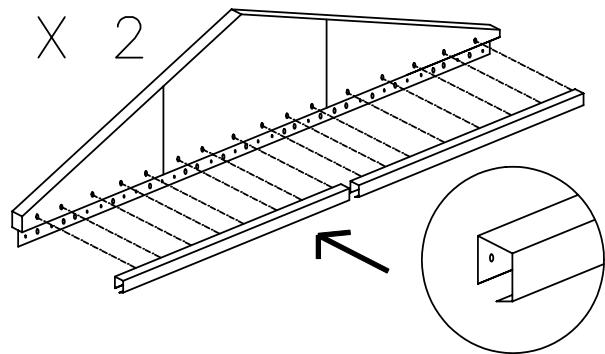

502.13 X 6 (1334mm)

502.19 X 12 (1984mm)

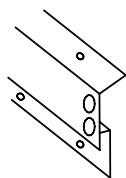
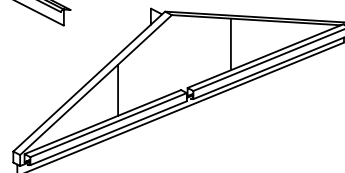

501.13 X 2 (1334mm)

501.19 X 4 (1984mm)

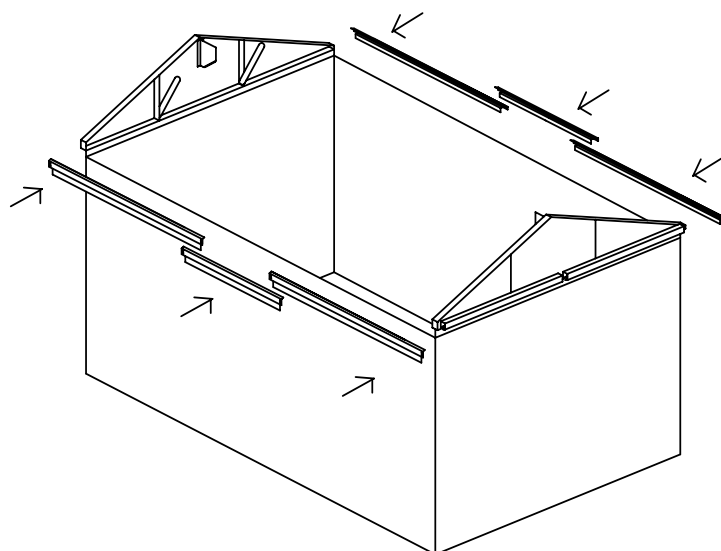

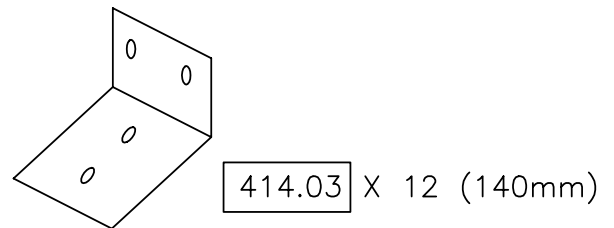
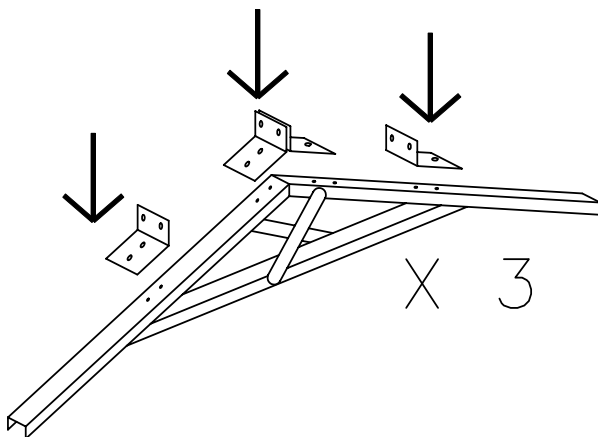
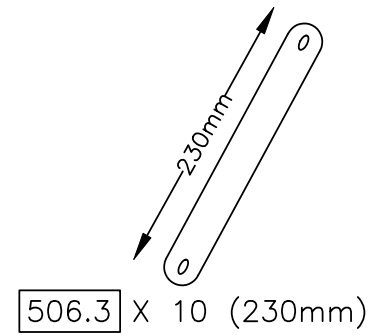
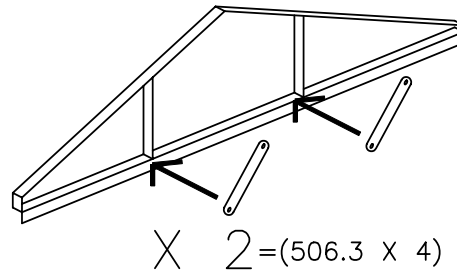
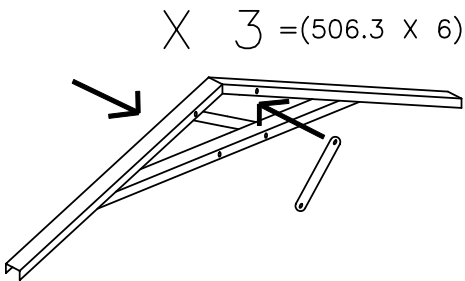
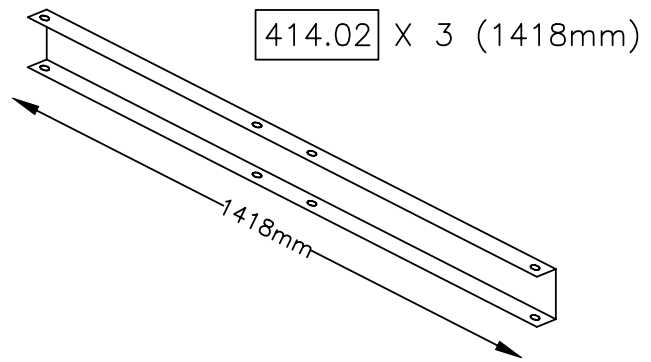
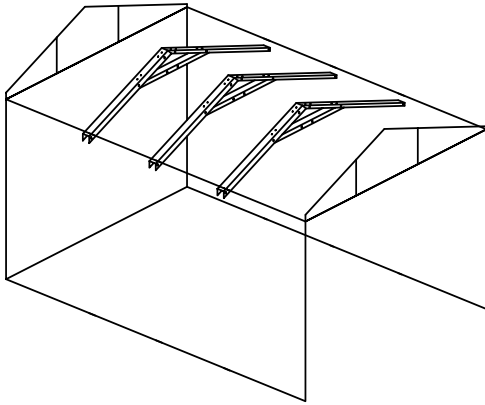
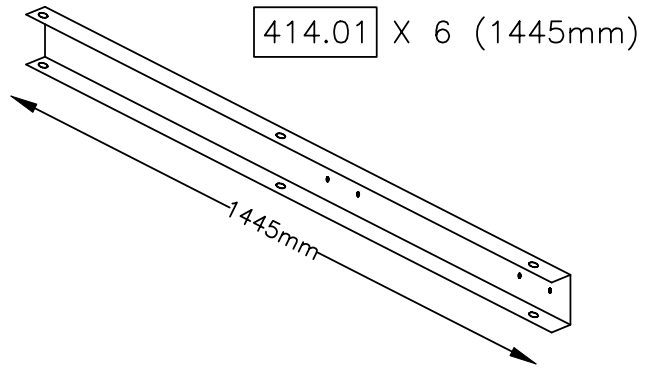
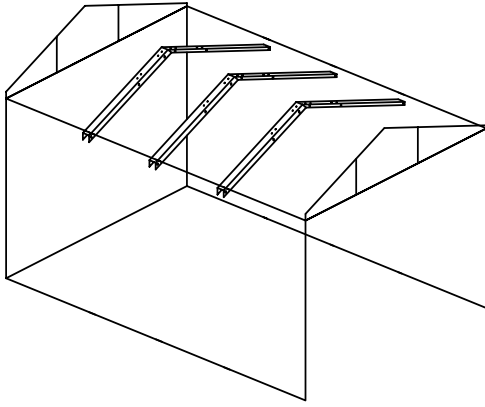

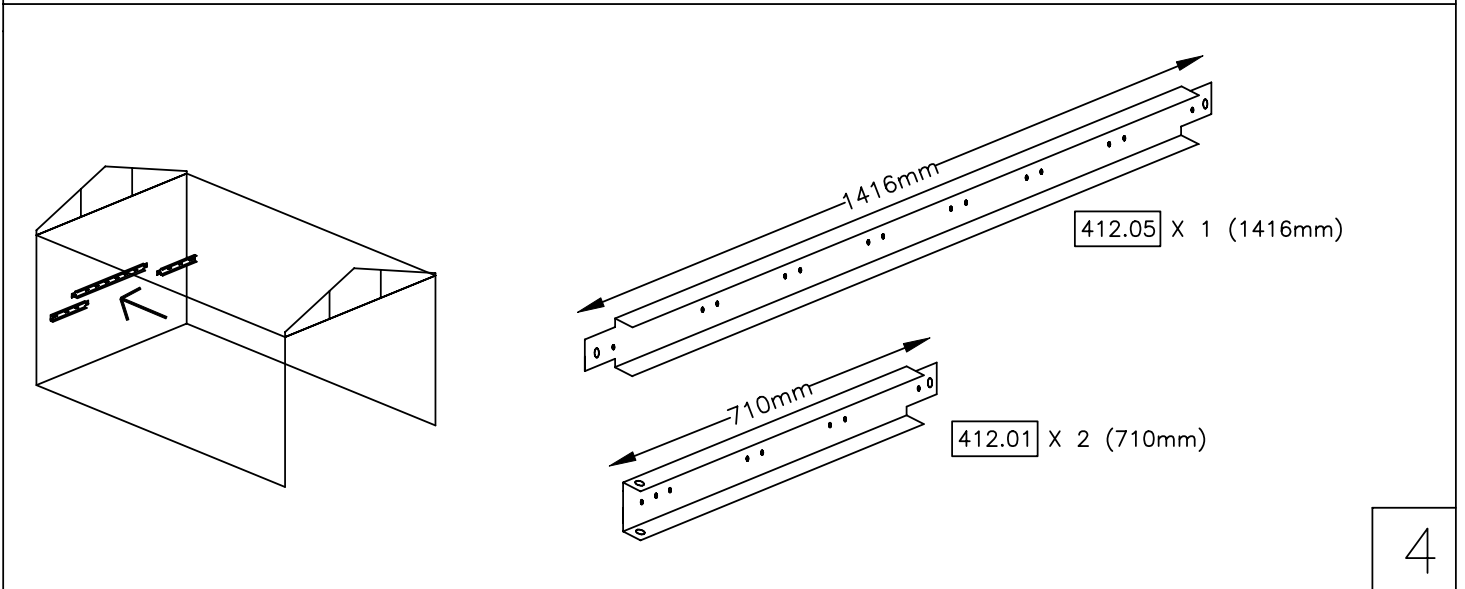
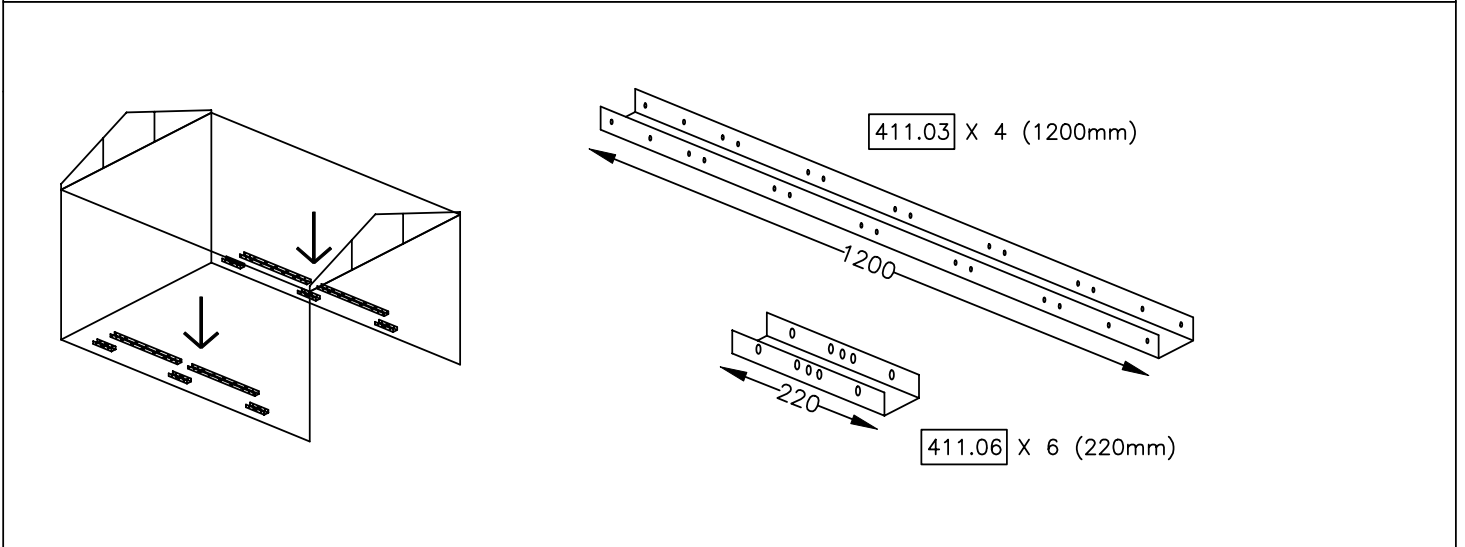
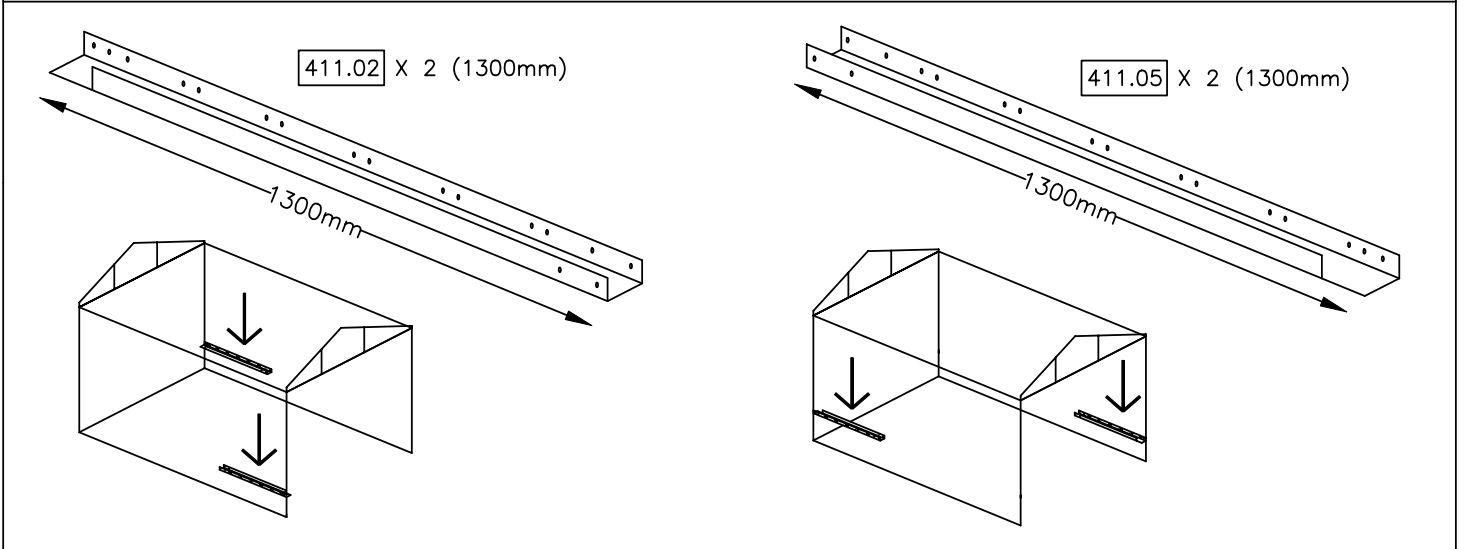
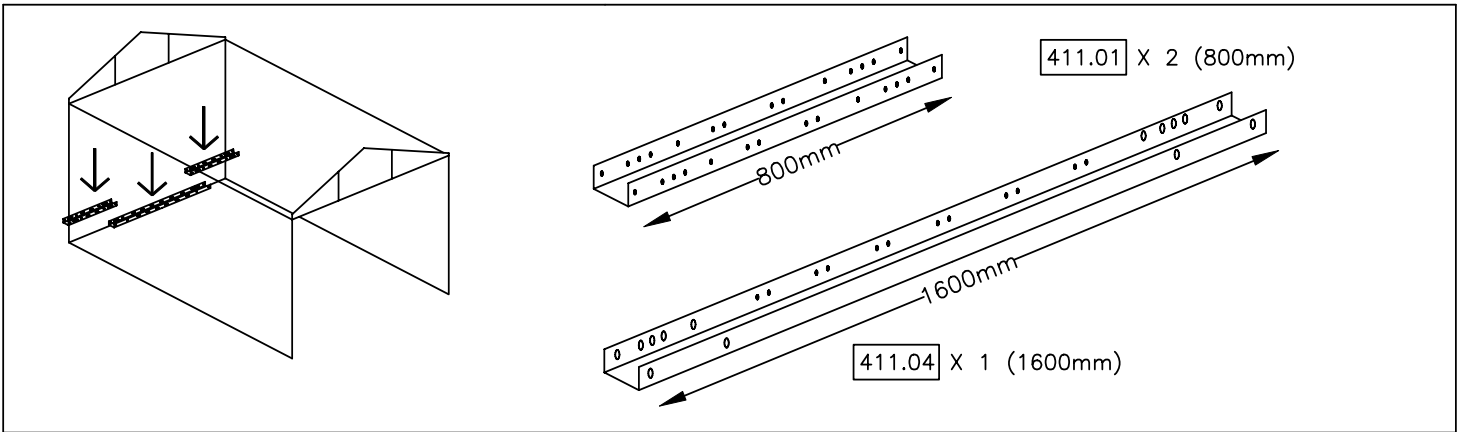

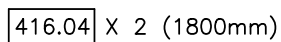
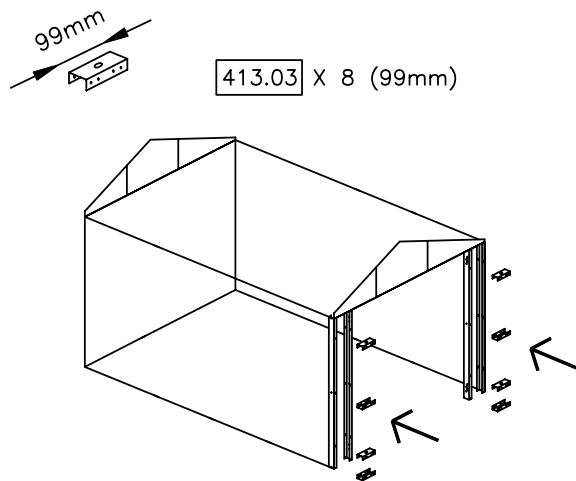
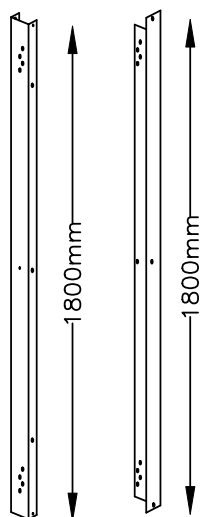
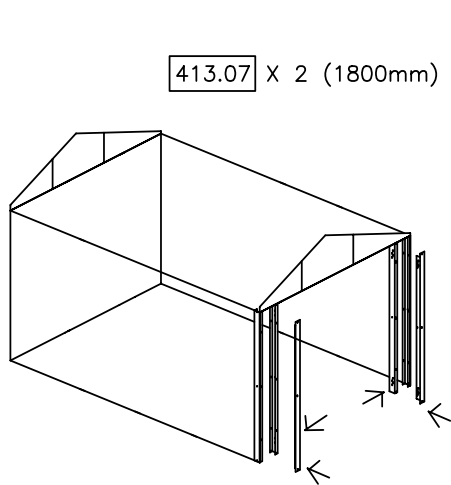
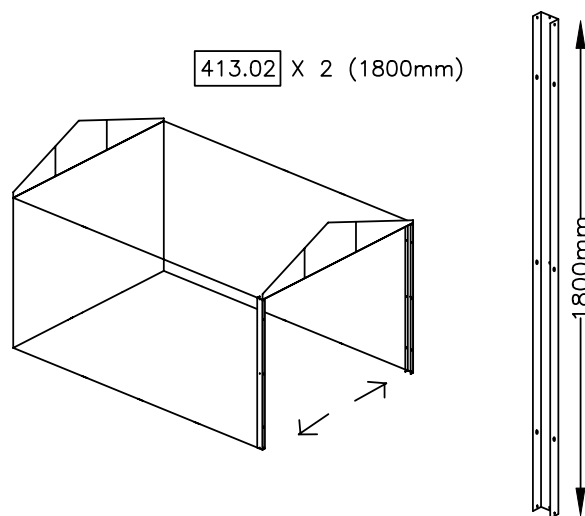
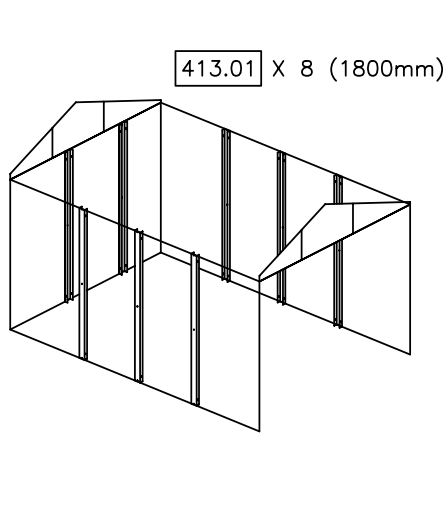
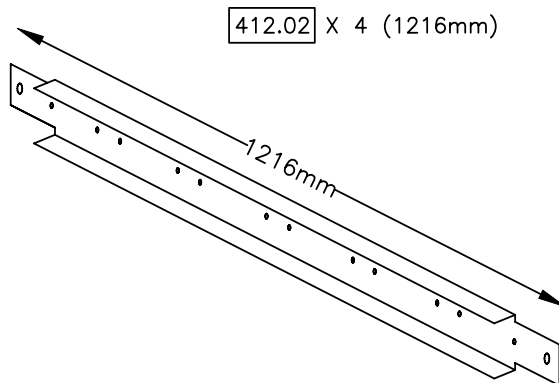
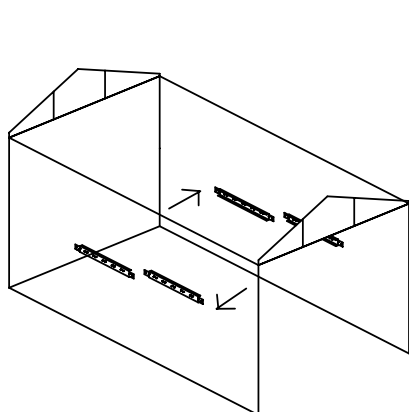
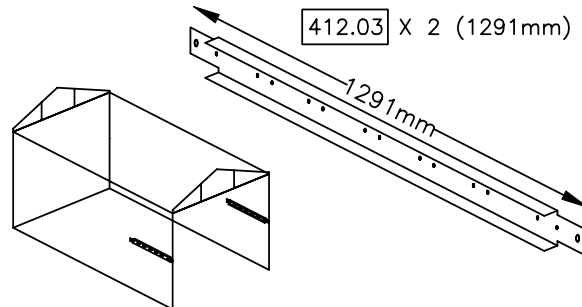
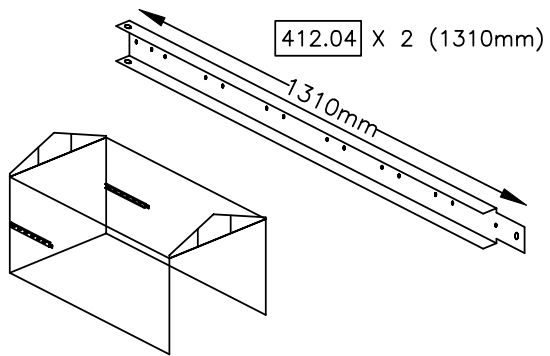

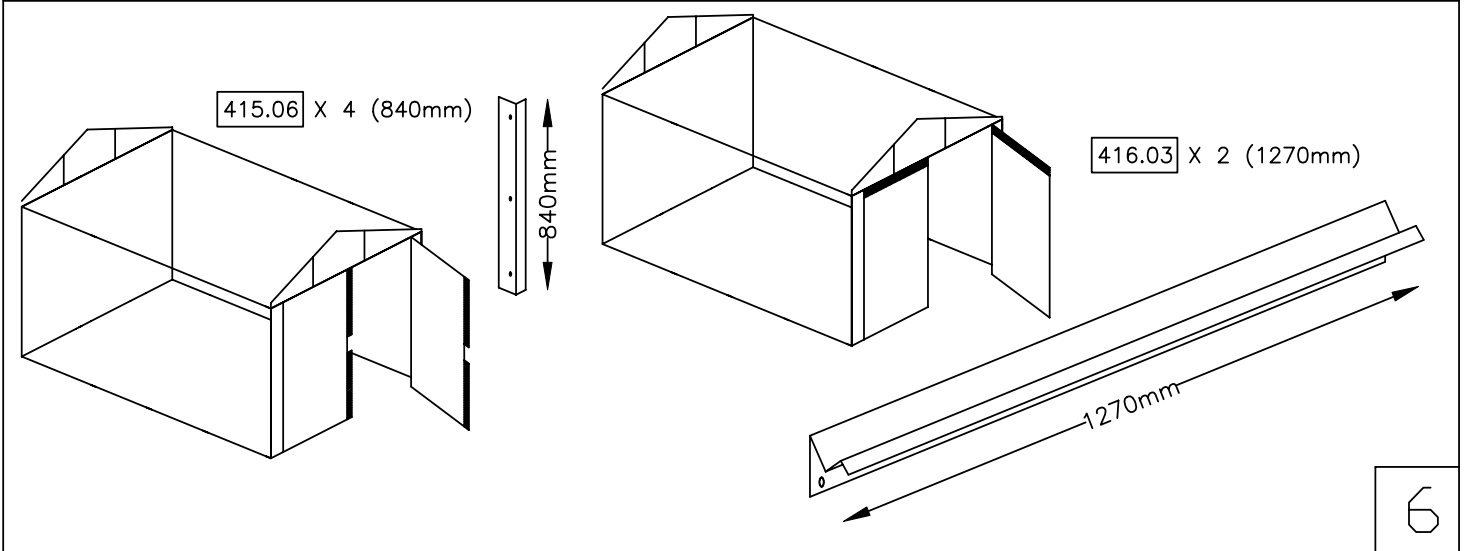
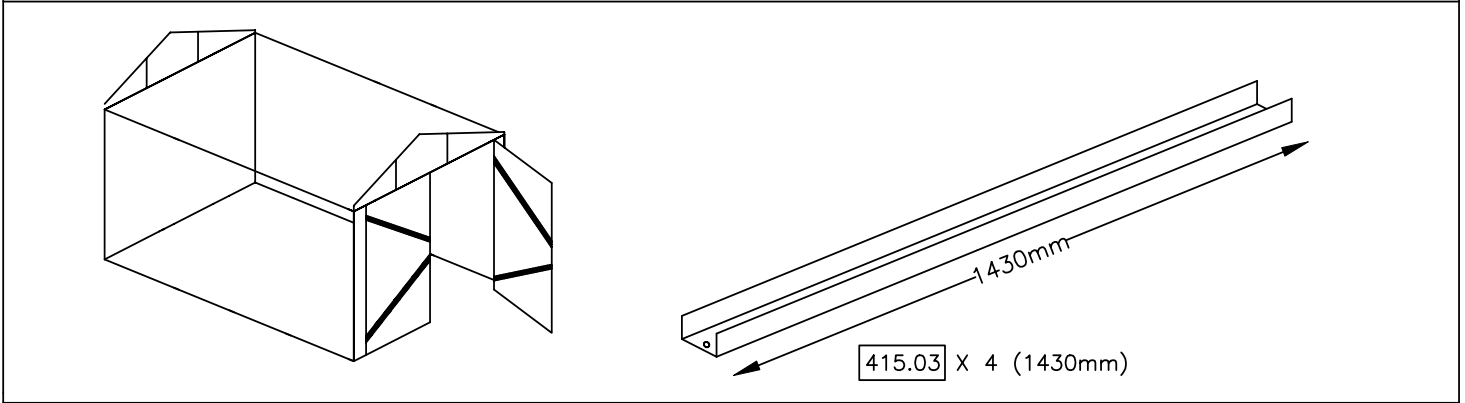
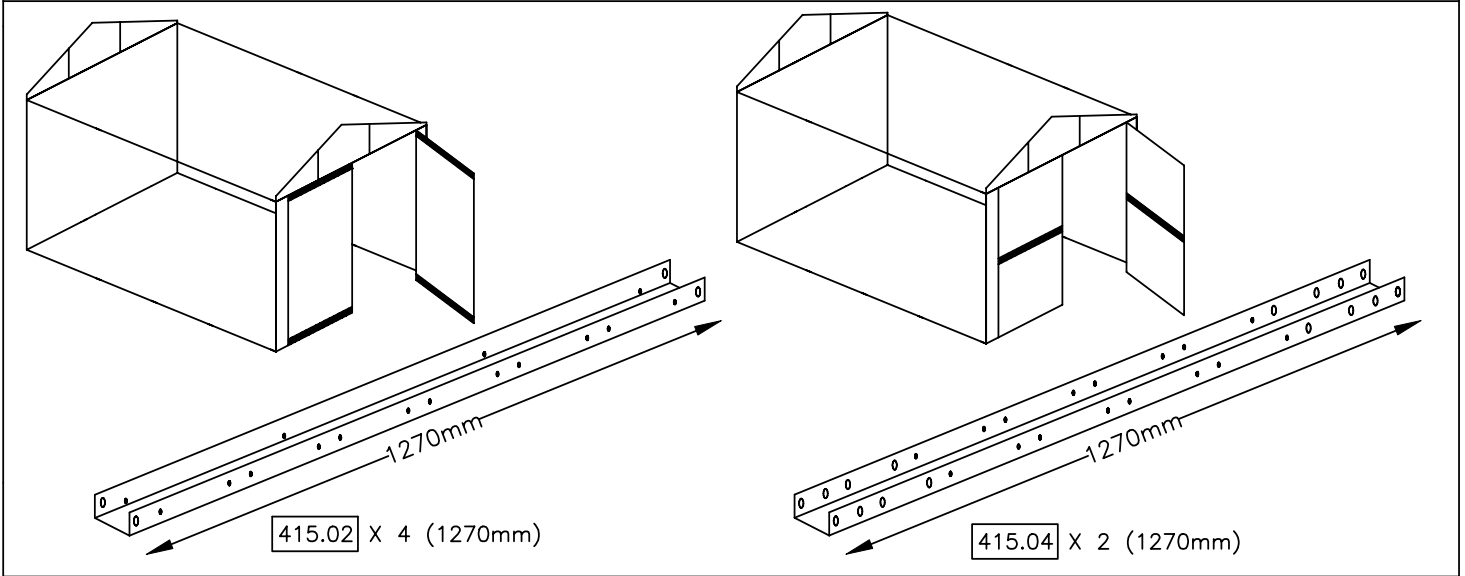
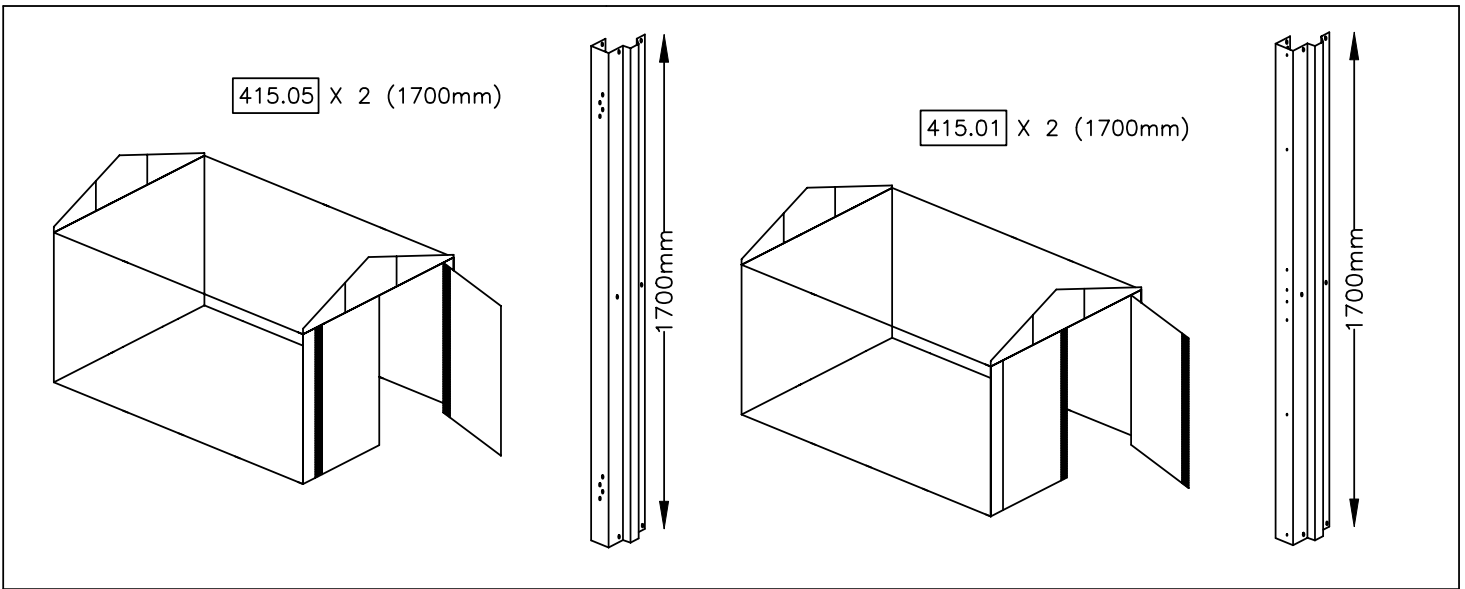

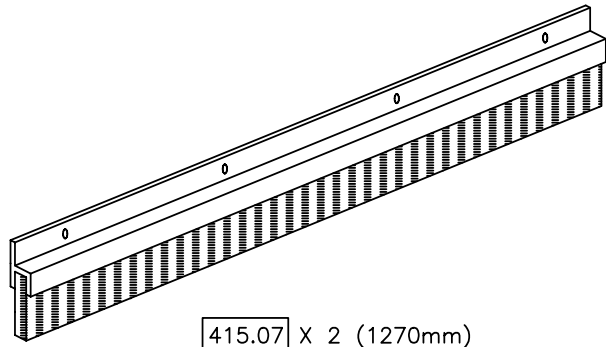
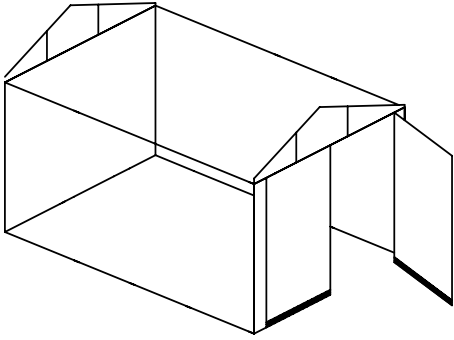

415.07 X 2 (1270mm)

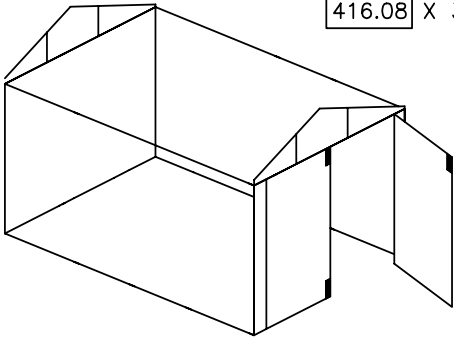

416.08 X 3

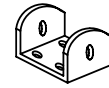
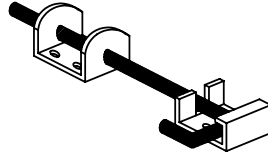

X 3 (36mm)

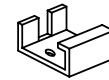

X 3 (35mm)

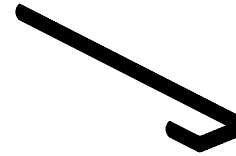

X 3 (165mm)

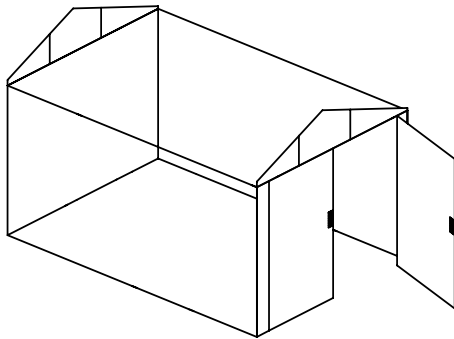

416.09 X 2 (43mm)

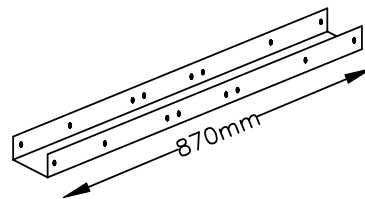
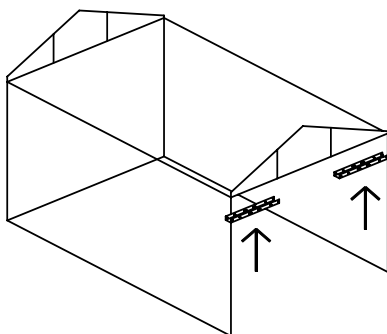
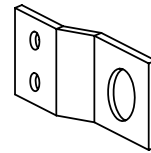

413.05 X 2 (870mm)



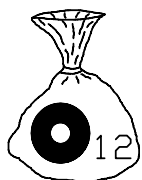
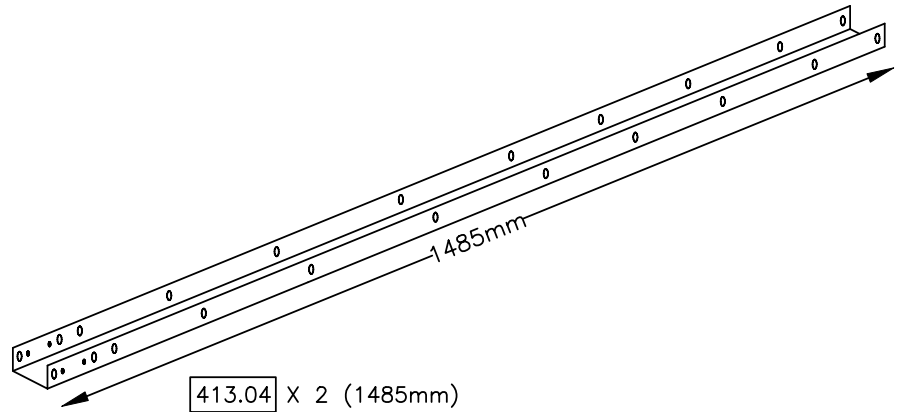
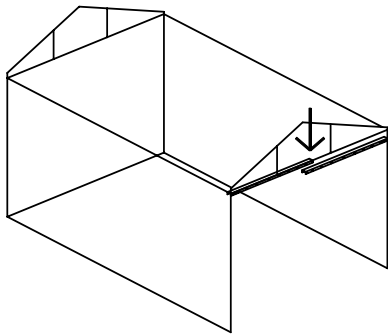
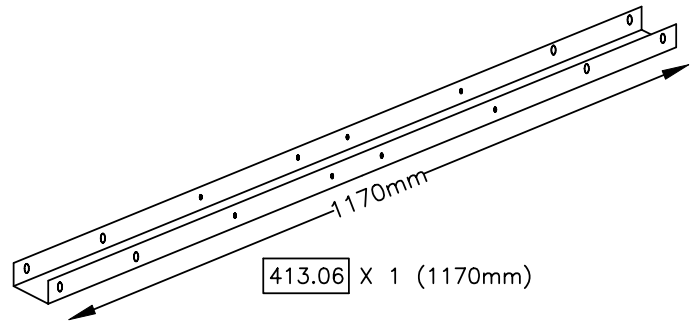
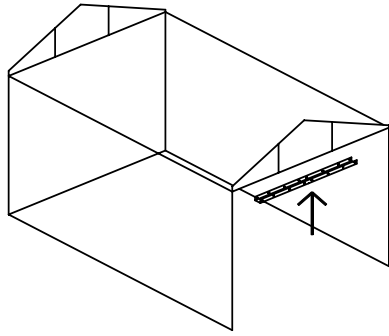

11X4mm

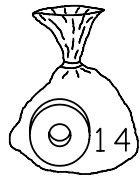

12X4mm

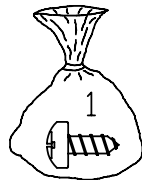
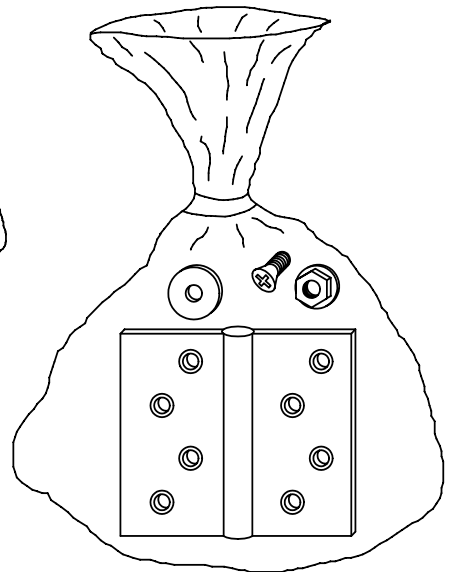
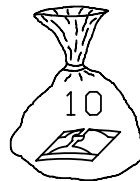
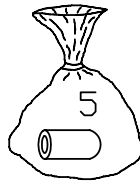

8X9mm

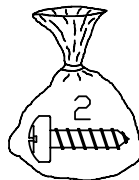

8X12mm

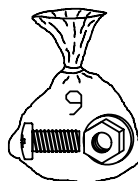

M5X12mm

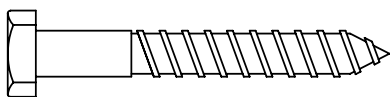

M8X50mm X 13

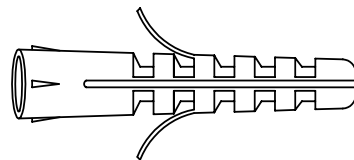

M10X50mm X 13

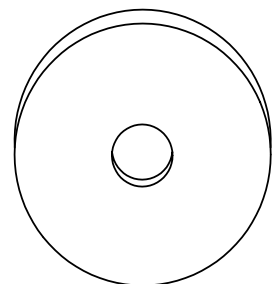

X 13

STEP 1 ROOF TRUSS ASSEMBLY X 3 / ASSEMBLAGE DU TOIT, CHARPENTE X 3

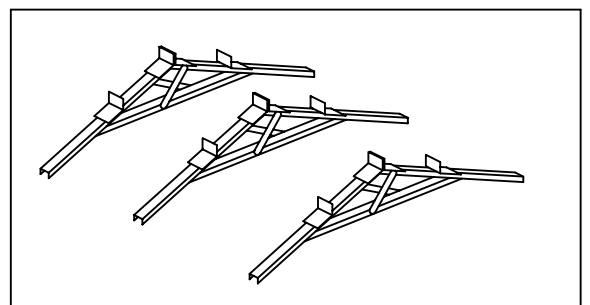
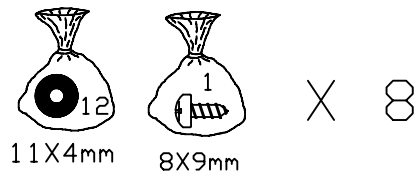
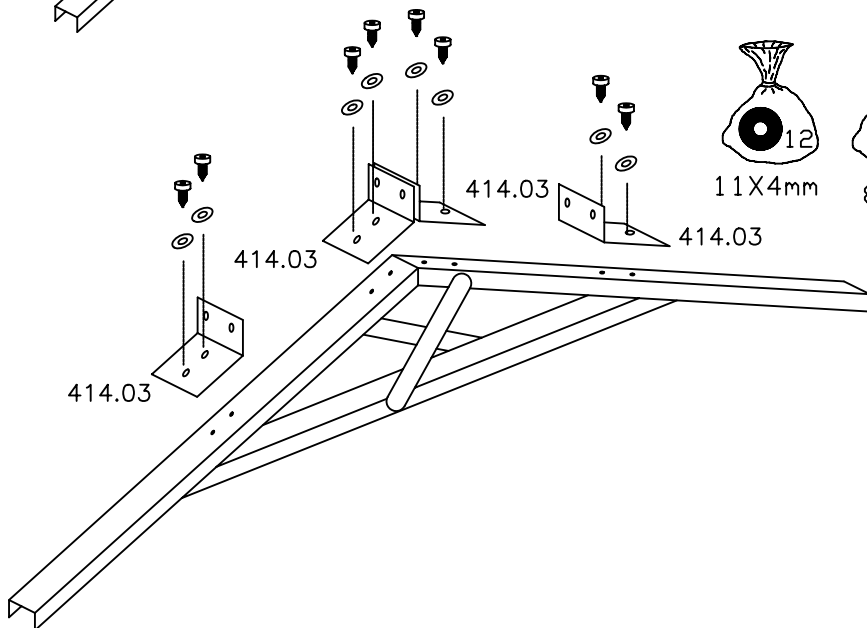
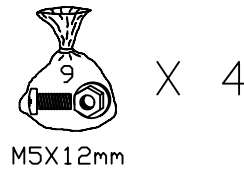
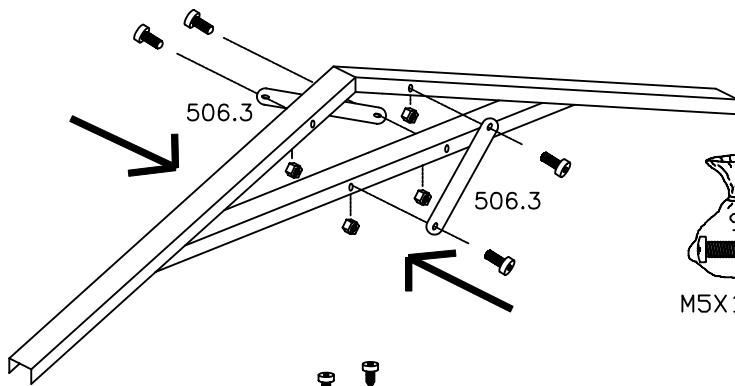
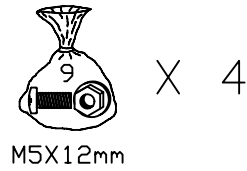
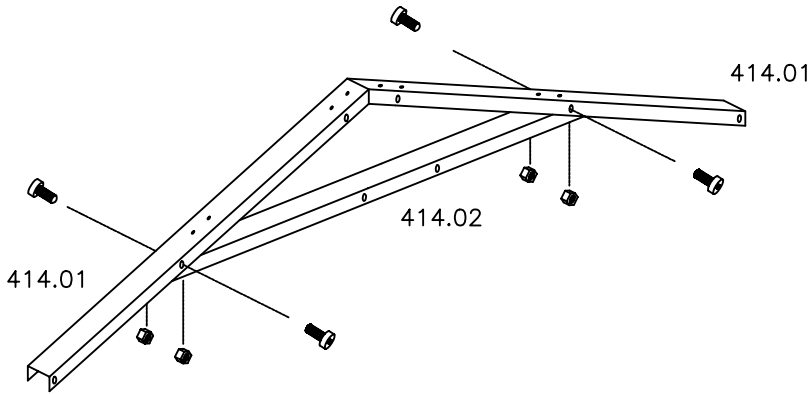
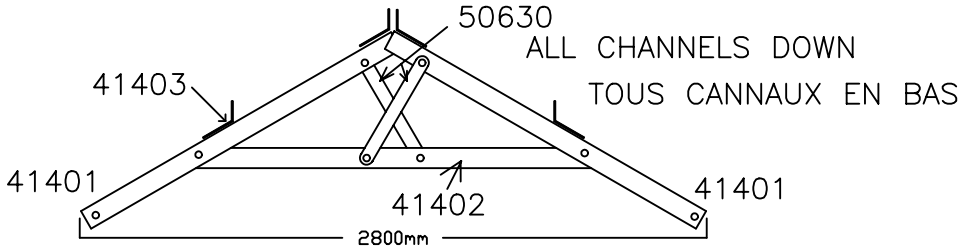
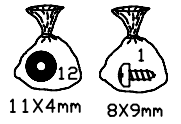
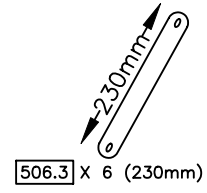
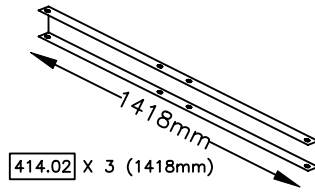
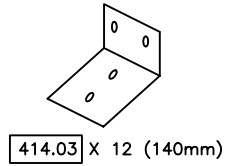
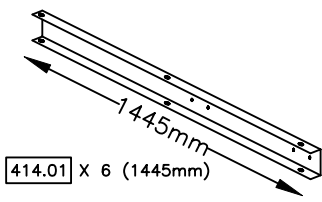

STEP 2 GABLE ASSEMBLY X 2 / ASSEMBLAGE DU PIGNON X 2

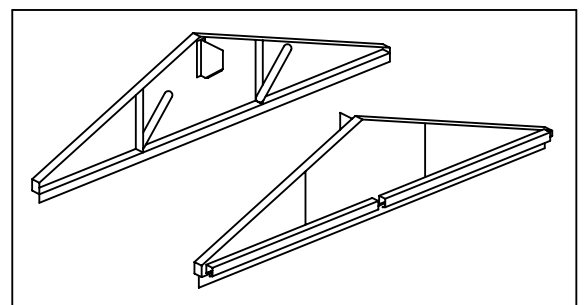
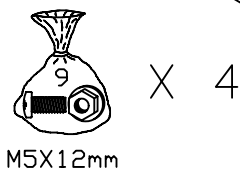
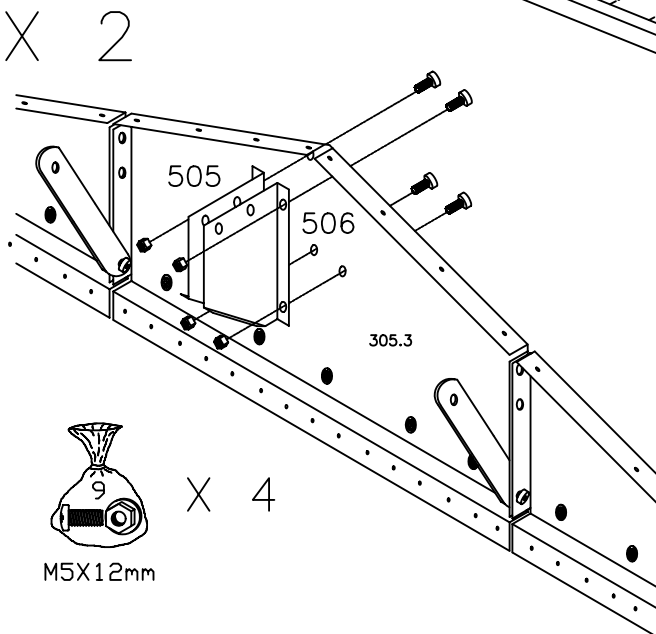
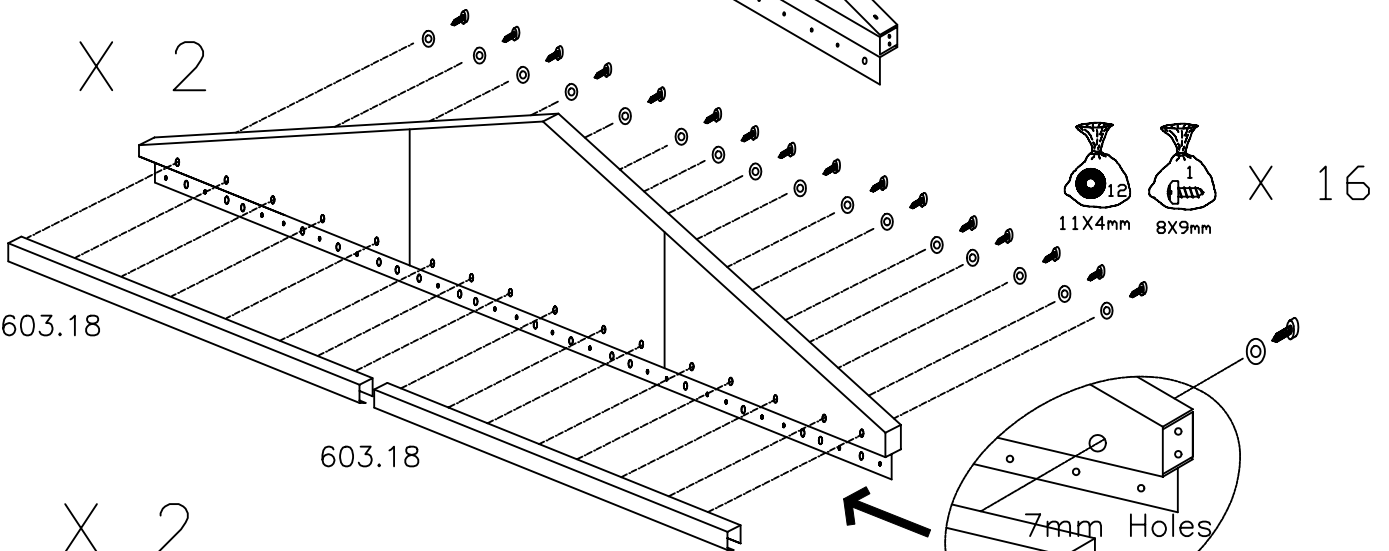
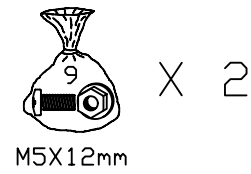
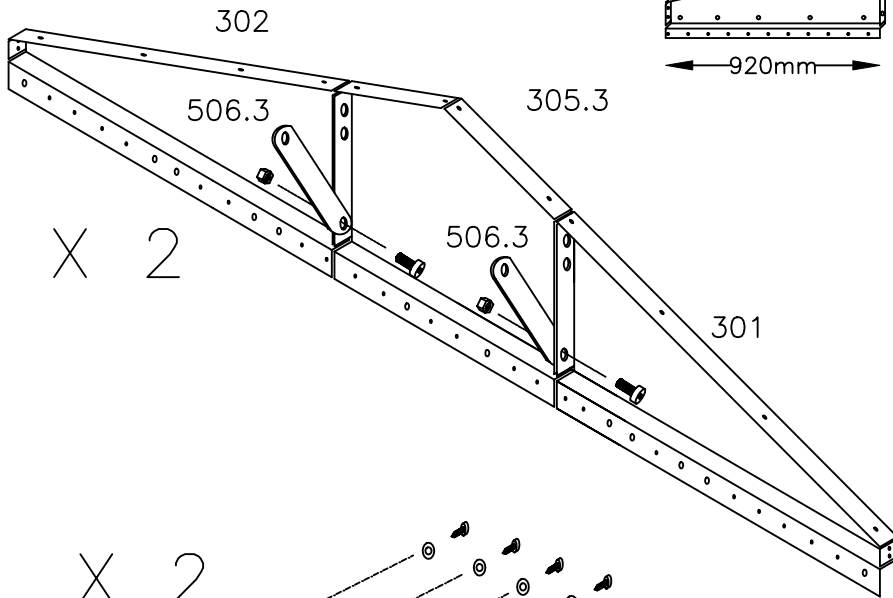
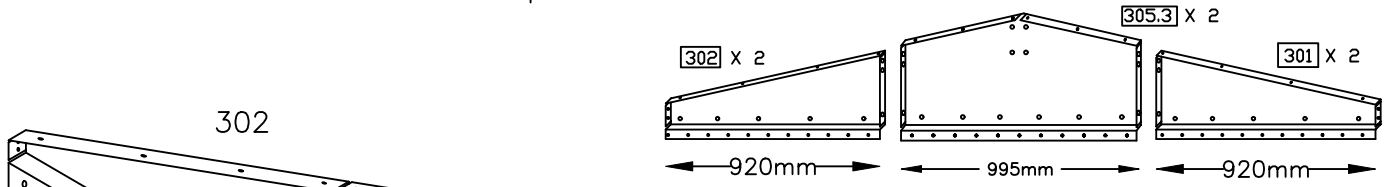
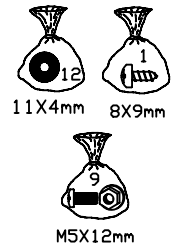
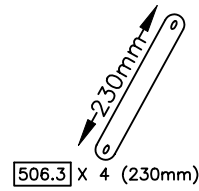
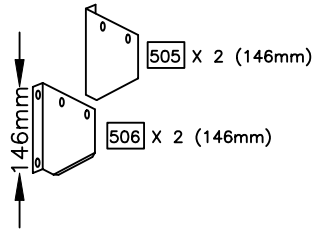
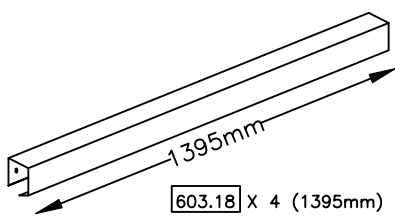

# STEP 3 DOOR FRAME ASSEMBLY X 2 / MONTAGE DES PORTES X 2

415.05 X 2 (1700mm)

415.01 X 2 (1700mm)

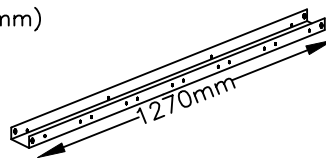
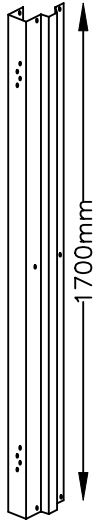

415.02 X 4 (1270mm)

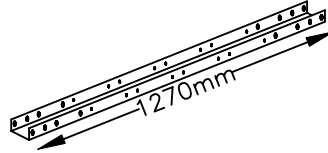

415.04 X 2 (1270mm)

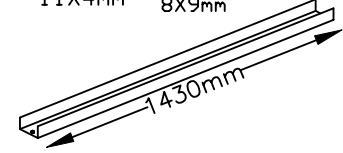

415.03 X 4 (1430mm)



M5X12mm



11X4mm



8X9mm

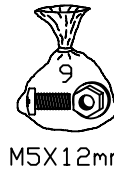
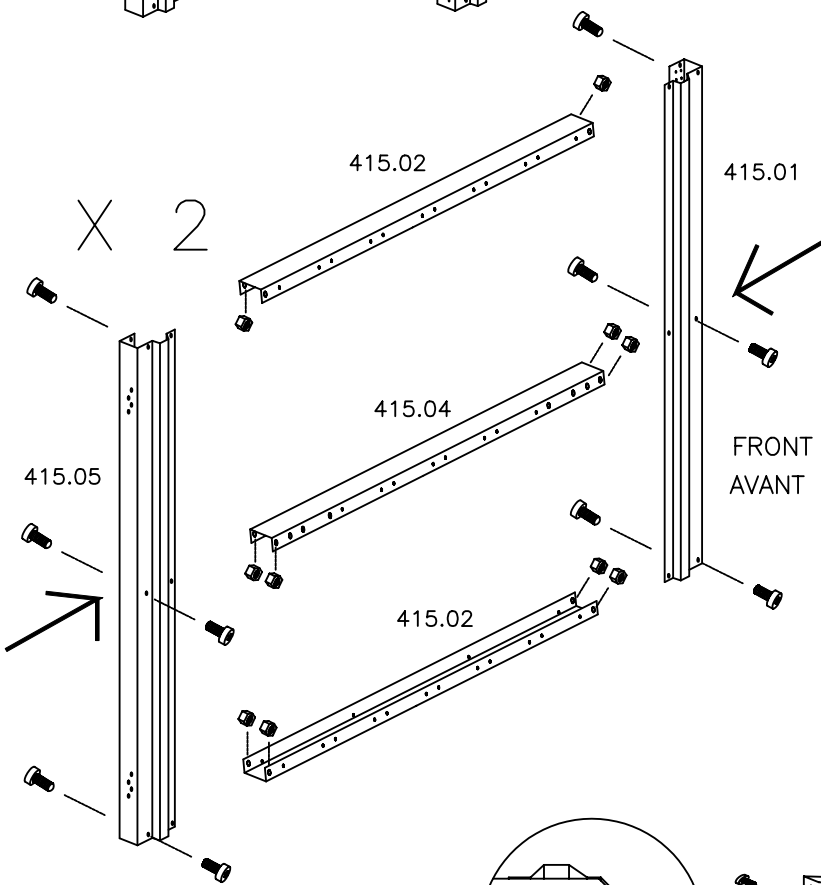

M5X12mm

X 10



11X4mm



8X9mm

X 4

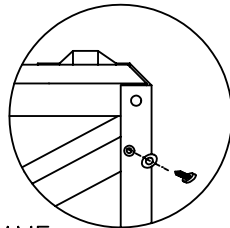

ATTENTION: ENSURE COMPLETED FRAME IS SQUARE.  
S'ASSURER TOUJOURS DE LA RECTITUDE DE LA STRUCTURE.

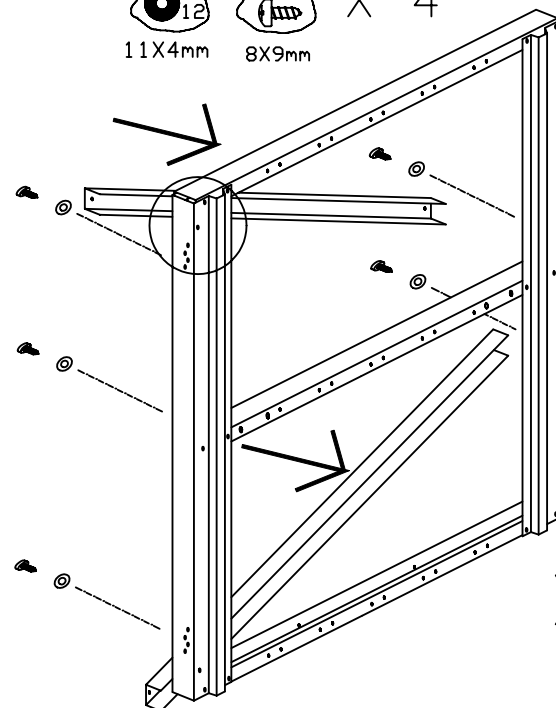
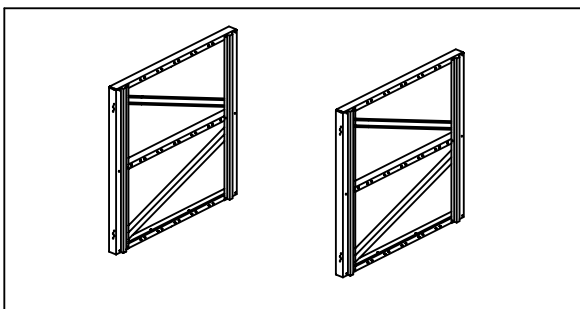



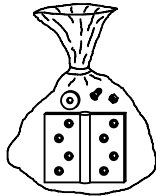
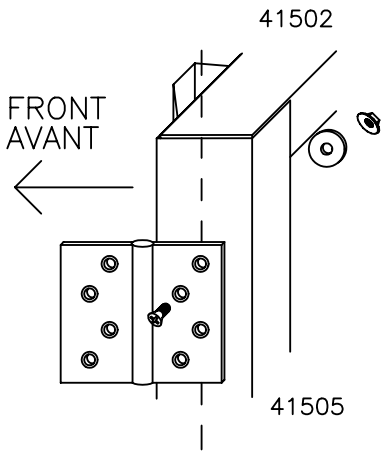
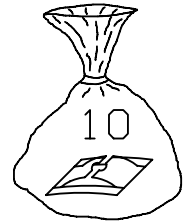
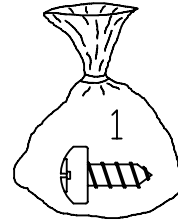
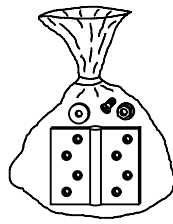
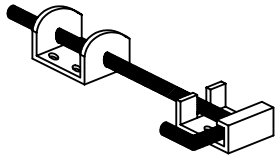

X 2

STEP 3 DOOR FRAME ASSEMBLY X 2 / MONTAGE DES PORTES X 2

416.08 X 3



-  X 4
-  X 16
-  X 16
-  X 16

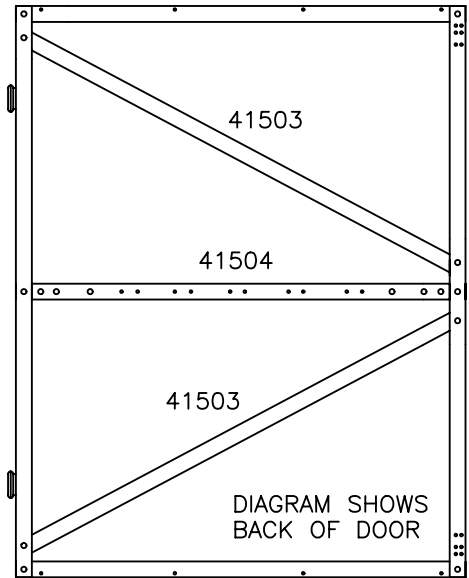
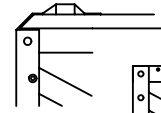

ALWAYS ENSURE HOLES TO LOCATE HINGES ARE TOWARDS OUTSIDE OF DOOR

TOUJOURS S'ASSURER QUE L'EXTREME DES GONDS SOIT PLACEE A L'EXTERIEUR DE LA PORTE.

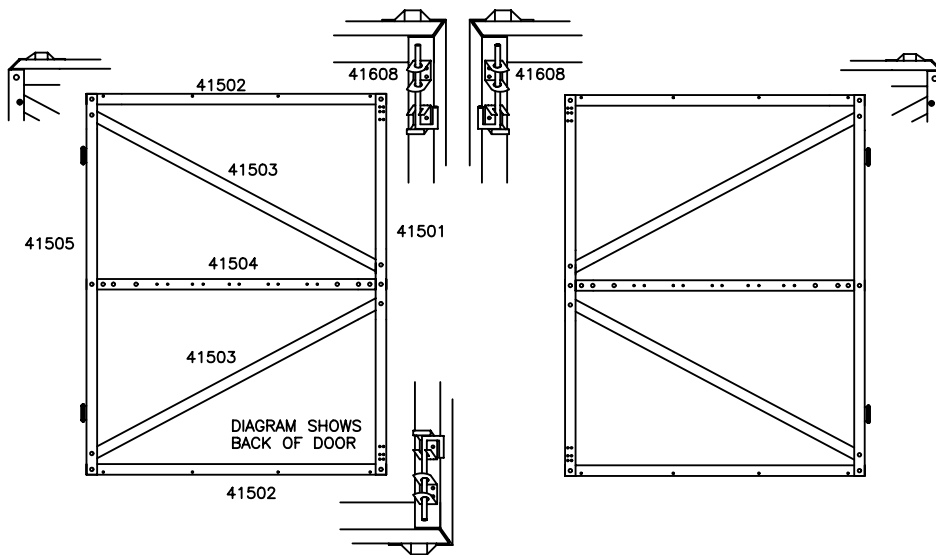

41502



-  X 18
-  X 18

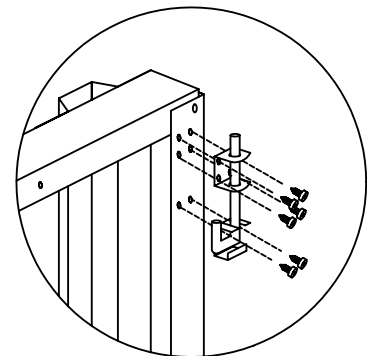

41608

WITH SCREWS BAG 1 AND SPIRE CLIPS BAG 10.

AVEC LA VISSERIE DE LA POCHETTE NO. 1 ET LES CLIPS DE LA POCHETTE NO. 10

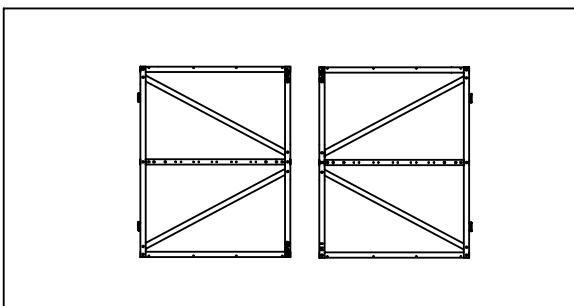

# STEP 3 DOOR PANEL ASSEMBLY X 2 / MONTAGE DES PORTES X 2

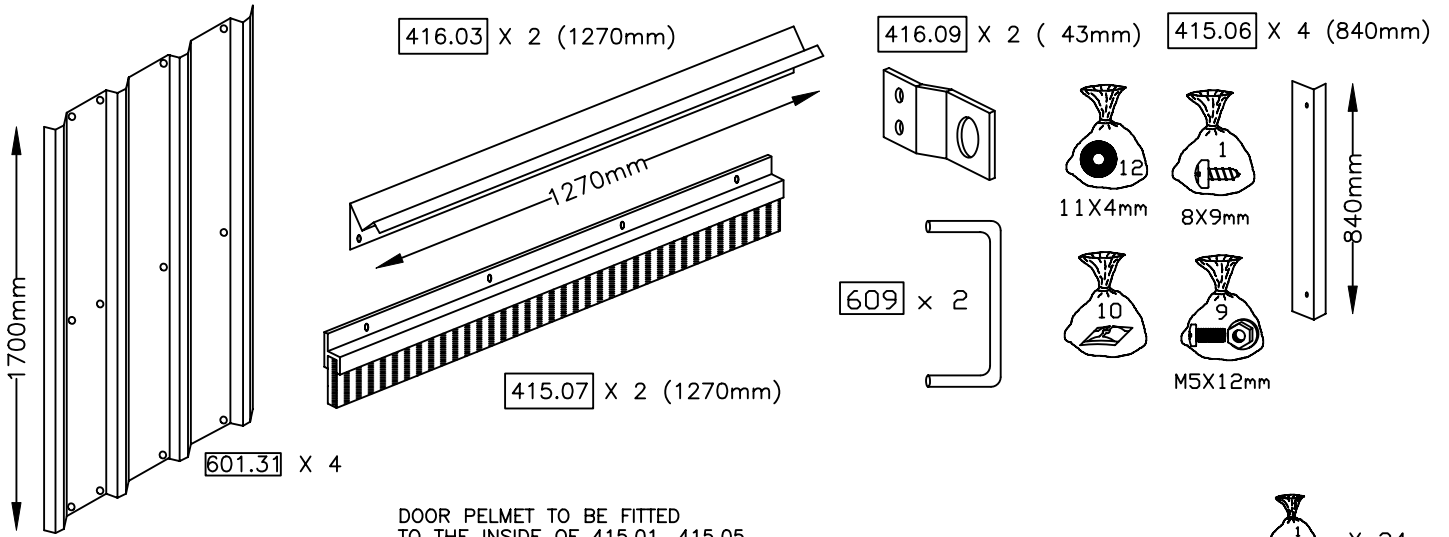

DOOR PELMET TO BE FITTED TO THE INSIDE OF 415.01, 415.05 AND 601.31 CLADDING PANEL

LA FAITIERE DE PORTE DOIT ETRE FIXEE EN HAUT, DERRIERE LE SUPPORT DE PANNEAU DE PORTE

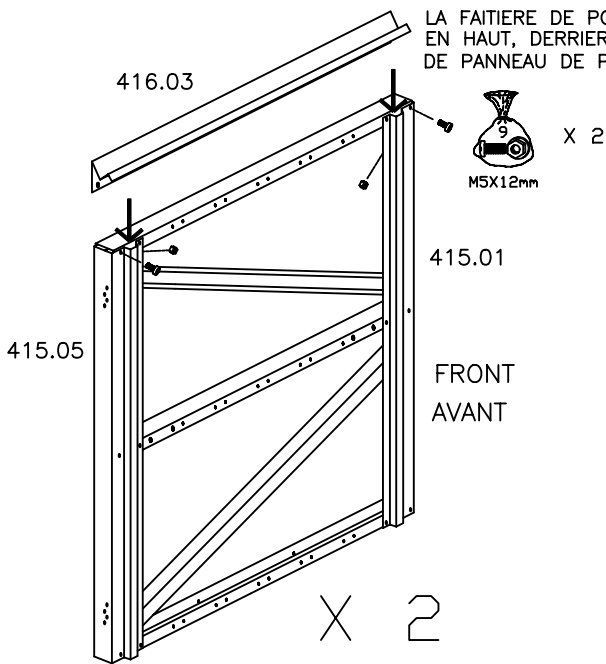

USE SCREWS (BAG 1) WASHERS, & SPIRE NUTS TO COVER HANDLE HOLES (7mm) AVEC LA VISSERIE DE LA POCHETTE NO. 1, RONDELLES EN FIBRE ET LES CLIPS DE LA POCHETTE NO. 10.

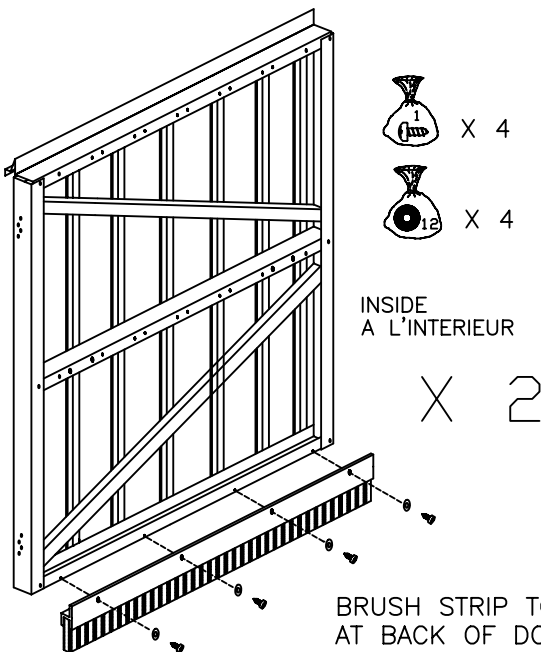
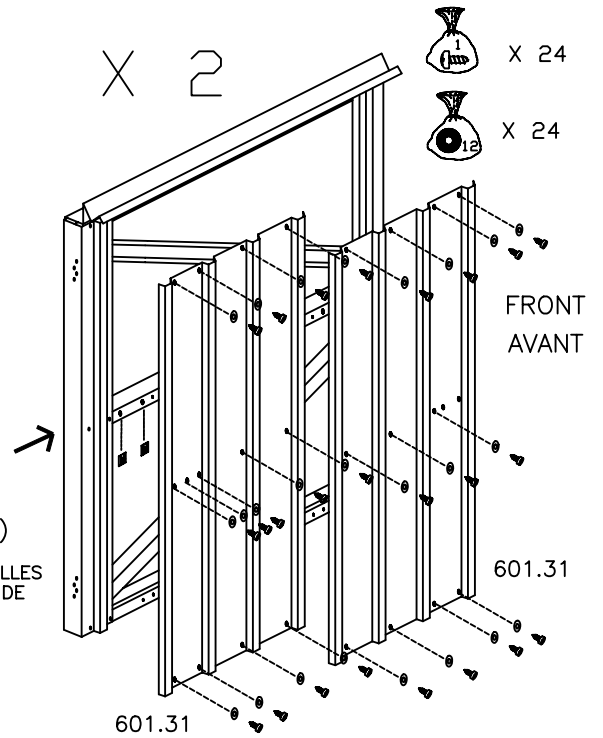

BRUSH STRIP TO BE FITTED AT BACK OF DOOR

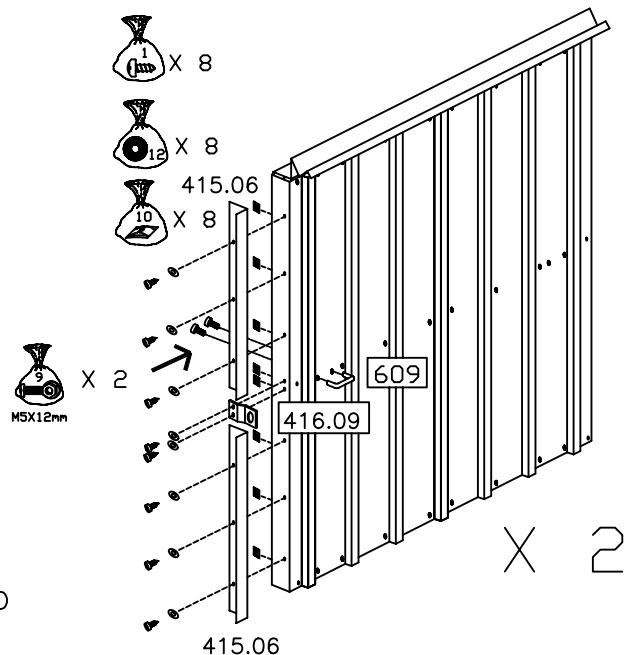

## STEP 4 ROOF BEAM ASSEMBLY X 3 / ASSEMBLAGE DES POUTRES DE TOIT X 3

### **ROOF BEAM SUB-ASSEMBLY**

1. Separate and lay flat all roof beams, 50213, 50219 and all roof beam splice plates 50200.
2. Place all roof beams in pairs and set back to back with the sloping sides facing down and away to form a "V" angle head.
3. Overlap one of the 50219 roof beams with one of the 50213 roof beams on the second and third holes on each beam as shown. Overlap other end of 50213 with another 50219.
4. Repeat step three.
5. Place a pair of roof beams back to back and splice together with splice plates 50200 on either side using 4 bolts and nuts (bag 9).
6. Construct two more of these assemblies.

### **ASSEMBLAGE DES POUTRES DE TOIT**

1. SEPARER ET POSER A PLAT TOUTES LES POUTRES FAITIERES 50213 ET 50219, PUIS POSITIONNER LES EQUERRES DE POUTRES 50200 PERMETTANT L'ASSEMBLAGE.
2. METTRE PAR PAIRIE TOUTES LES POUTRES DE TOIT DOS A DOS, LES PROFILES DEVANT ETRE TOURNES VERS L'EXTERIEUR.
3. ASSEMBLER LES POUTRES DE TOIT 50219 ET 50213 COMME INDIQUE SUR LE SCHEMA CI-DESSOUS, LAISSANT LIBRE LE DEUXIEME ET LE TROISIEME TROU.
4. REPETER (3).
5. FIXER LES EQUERRES DE POUTRE 50200 L'AIDE DES 4 BOULONS ET ECROUS (POCHETTE NO.9). VOUS ASSURER QU'EN AJUSTANT LES EQUERRES, 2 TROUS SERONT LAISSES LIBRES SUR LES POUTRES LONGUES, ET 2 TROUS SUR LES POUTRES COURTES.
6. REALISER CE TYPE D'ASSEMBLAGE POUR LES 3 POUTRES DE TOIT.

# STEP 4 ROOF BEAM ASSEMBLY X 3 / ASSEMBLAGE DES POUTRES DE TOIT X 3

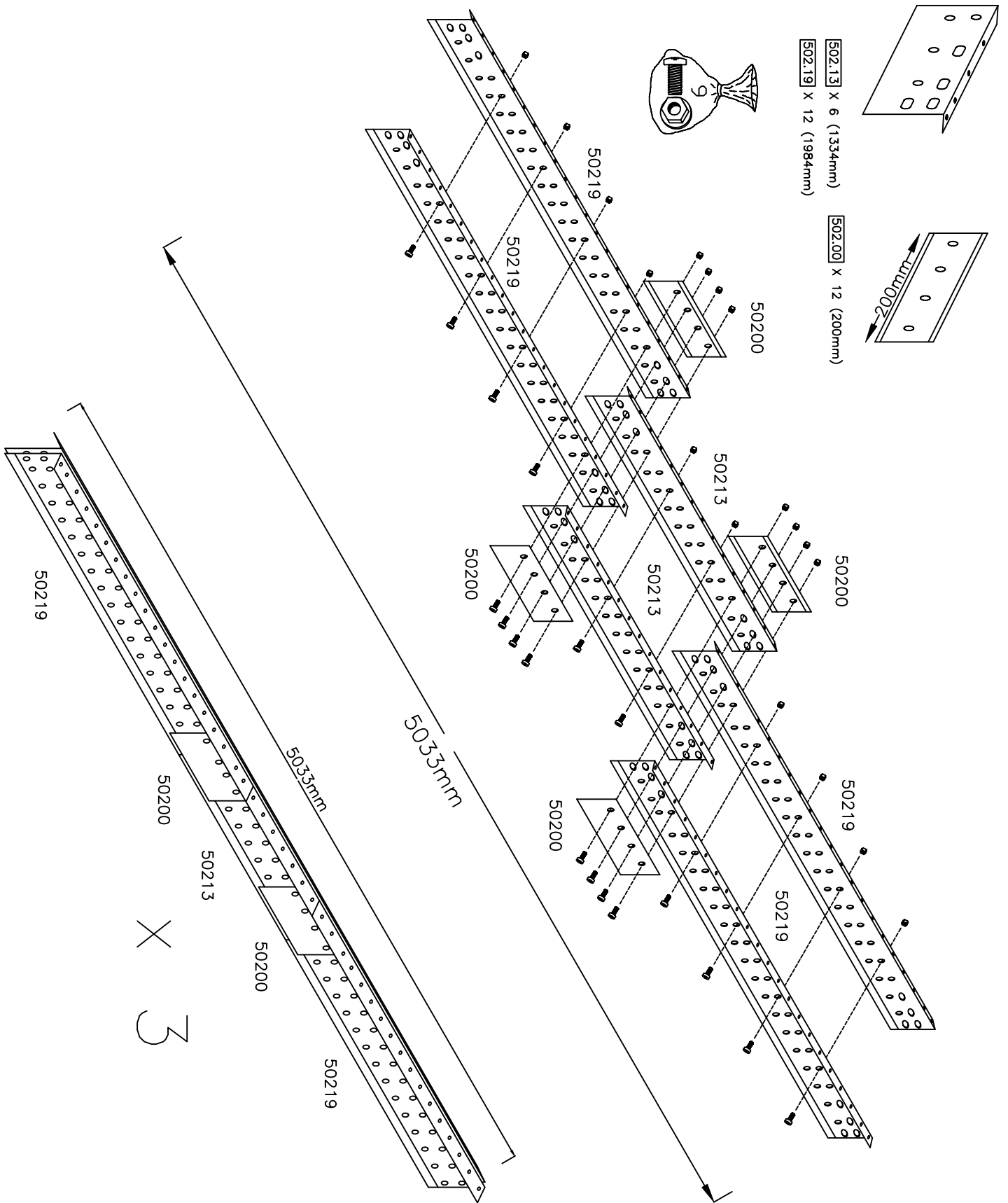



## STEP 5 FRONT FRAME ASSEMBLY / STRUCTURE FRONTALE

### **FRONT FRAME POST.**

1. Select one 41302 and one 41307, fix together as shown with the front frame braces; 41303 using screws (bag 1) and (bag 12).
2. Repeat for other side of front frame.

**ALWAYS ENSURE HOLES TO LOCATE HINGES ARE TOWARD OUTSIDE OF FRONT FRAME. ENSURE COMPLETED FRAME IS SQUARE**

### **FRONT FRAME.**

1. Line up holes on both 41304's as shown (fig 1).
2. Fix into channel both 41305's with the third hole in from either end lining up (fig 2).
3. Central to this channel line up 41306.
4. Fix together at overlaps with screws (bag 1) (fig 3).
5. Attach front frame posts to both ends in order to complete the front frame assembly.

### **PROFILE DE PILLER DE FACADE**

1. ASSEMBLER LES PROFILS D'ANGLE 41302 ET 41307 COMME INDIQUE CI-DESSOUS AVEC LES PROFILS DE FACADE, A L'AIDE DE LA VISSERIE DES Pochettes NO.1 ET NO.12.
2. IDEM POUR LE PILLER DE FACADE DROIT.

**TOUJOURS S'ASSURER QUE LES TROUS DEVANT RECEVOIR LES GONDS SOIENT SUR LES PROFILS EXTERIEURS DU PILLER.**

### **STRUCTURE FRONTALE**

1. SUPERPOSER LES DEUX PROFILS 41304 COMME INDIQUE (FIG 1).
2. FIXER AU TROISIEME TROU, A L'INTERIEUR DU PROFILE DE FACADE, LES DEUX PROFILS 41305 (FIG 2).
3. PLACER LE PROFILE CENTRAL 41306.
4. VISSER L'ENSEMBLE AVEC LA VISSERIE DE LA Pochette NO.1 (FIG 3).
5. LA FIGURE 3 MONTRE L'ENSEMBLE DE LA STRUCTURE FRONTALE ASSEMBLEE AU PILLER DE FACADE.

# STEP 5 FRONT FRAME ASSEMBLY / STRUCTURE FRONTALE

413.05 X 2 (870mm)

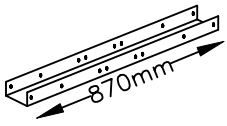

8X9mm



11X4mm

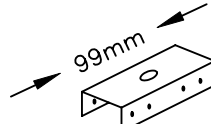

413.03 X 8 (99mm)



413.02 X 2 (1800mm)

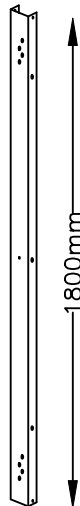

413.07 X 2 (1800mm)

413.06 X 1 (1170mm)

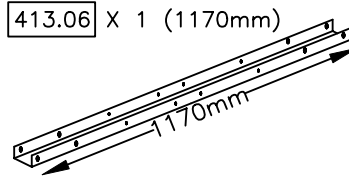

413.04 X 2 (1485mm)

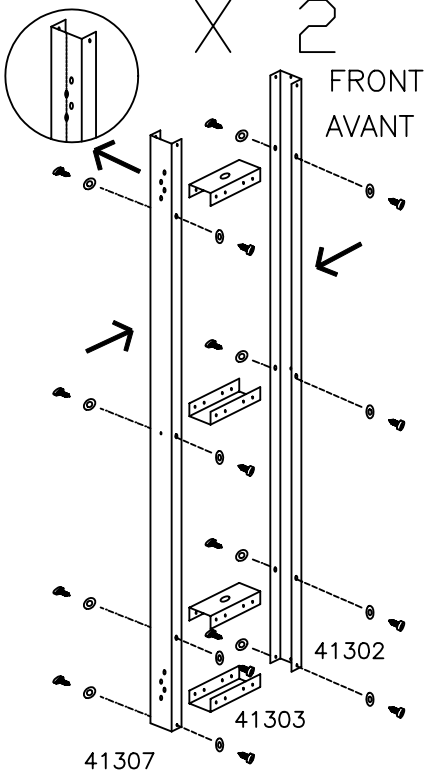
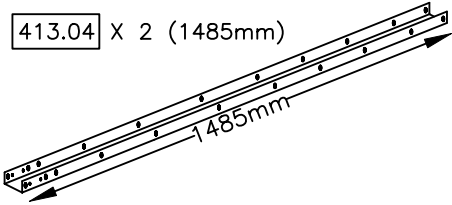

ALWAYS ENSURE HOLES TO LOCATE HINGES ARE TOWARDS OUTSIDE OF FRONT FRAME

TOUJOURS S'ASSURER QUE LES TROUS DEVANT RECEVOIR LES GONDS SOIENT SUR LES PROFILES EXTERIEURS.

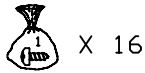

X 16

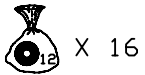

X 16

FIG. 1 41304

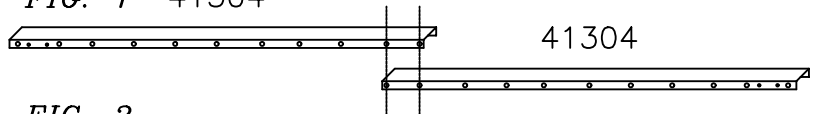

FIG. 2

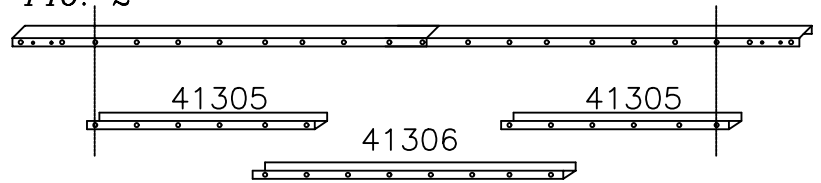
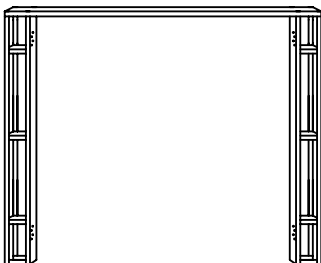
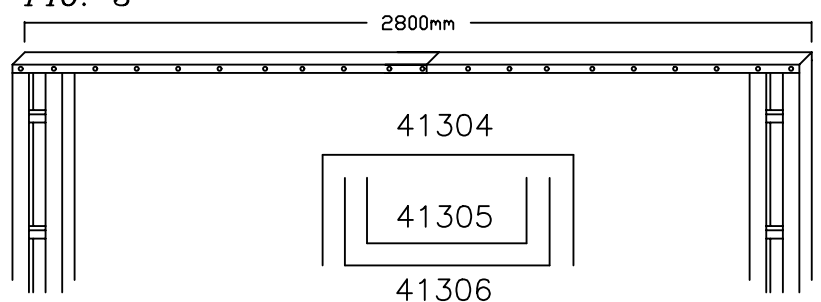

FIG. 3



## STEP 6 BACK SECTION ASSEMBLY / ASSEMBLAGE DE LA STRUCTURE ARRIERE

413.01 x 2 (1800mm)

411.01 x 2 (800mm)

411.04 x 1 (1600mm)

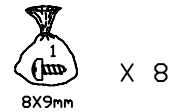
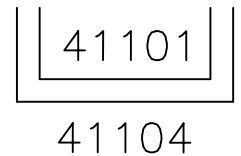
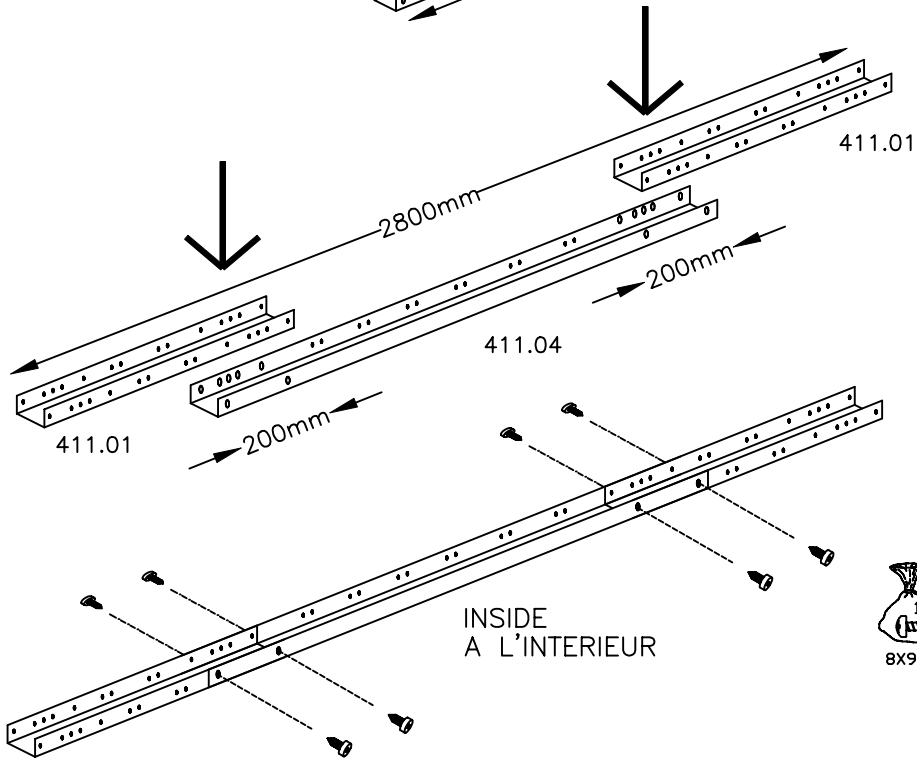
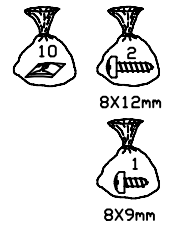
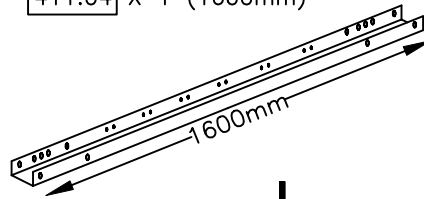
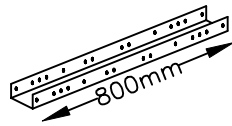

### BACK SECTION ASSEMBLY.

1. Overlap and attach two back base rails; 41101, to back intermediate base rail; 41104, on inside of either end of 41104 using screws (bag 1).
2. Fix 2 standard uprights; 41301, as shown to centre of back base rail overlaps using screws (bag 2) and spire nuts (bag 10).

### ASSEMBLAGE DE LA STRUCTURE ARRIERE

1. SUPERPOSER ET FIXER AUX DEUX POUTRES RENFORCEES 41101 LE RAIL DE BASE 41104, A L'AIDE DE LA VISSERIE DE LA POCHETTE NO. 1.
2. FIXER LES DEUX PROFILS D'ANGLE 41301 COMME INDIQUE CI-DESSOUS AU CENTRE DU RAIL DE BASE, A L'AIDE DE LA VISSERIE DE LA POCHETTE NO. 2 ET DES ECROUS DE LA POCHETTE NO. 10.

STEP 6 BACK SECTION ASSEMBLY / ASSEMBLAGE DE LA STRUCTURE ARRIERE

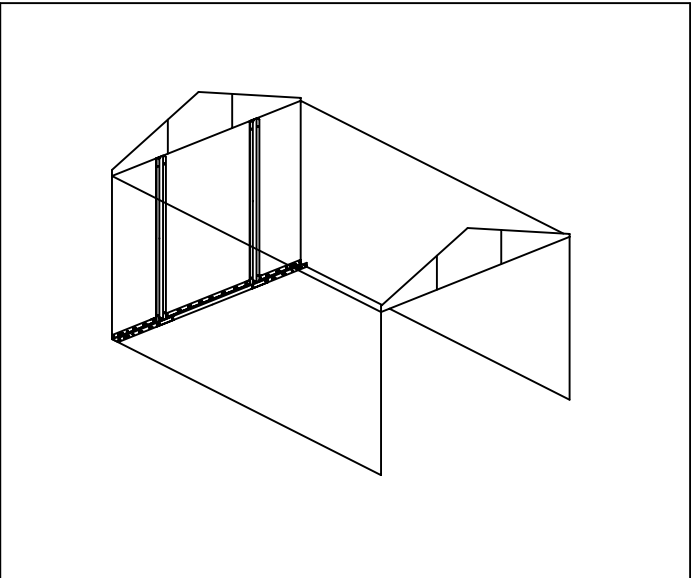
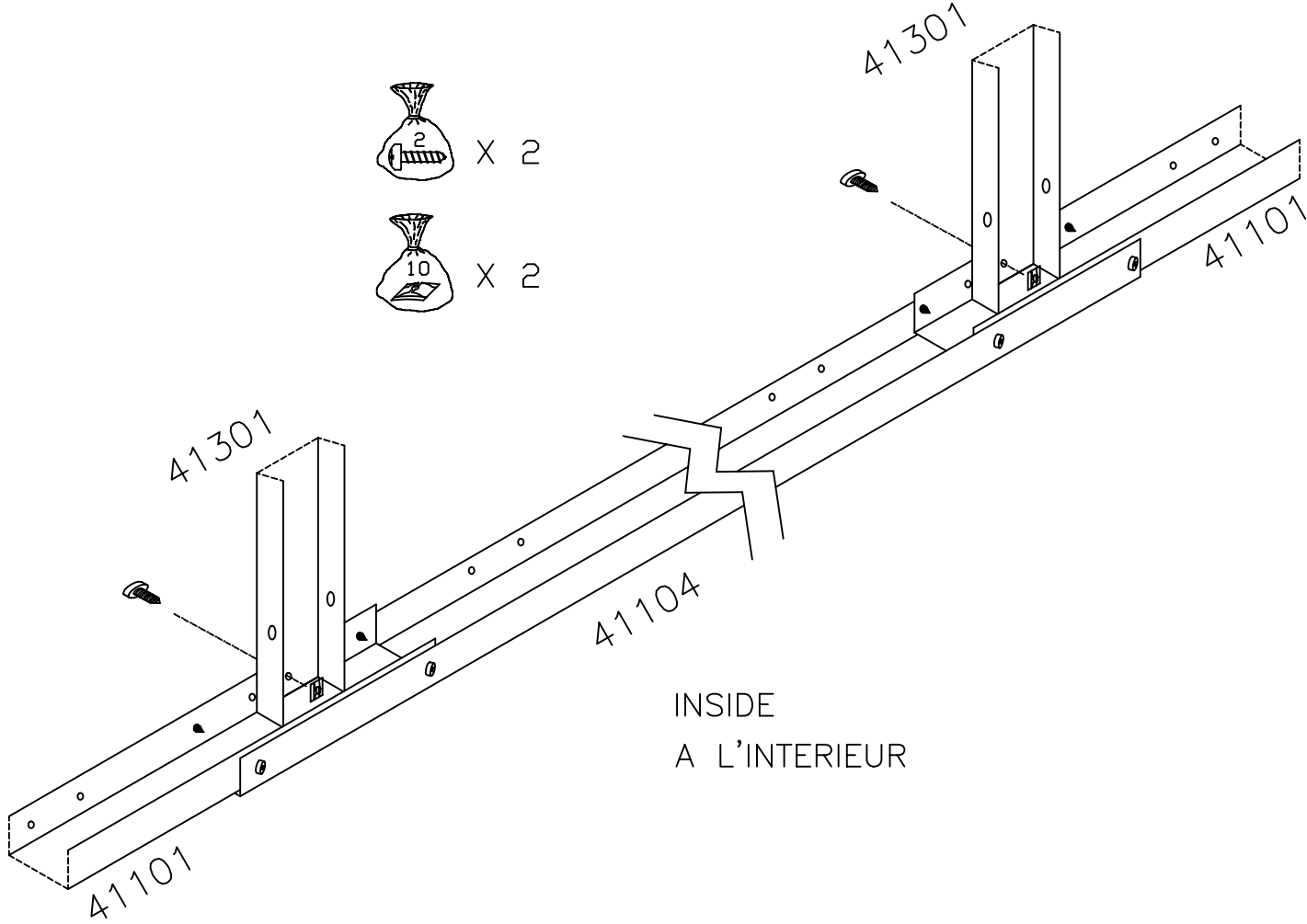

## STEP 7 BACK PANEL ASSEMBLY / ASSEMBLAGE DE LA STRUCTURE ARRIERE

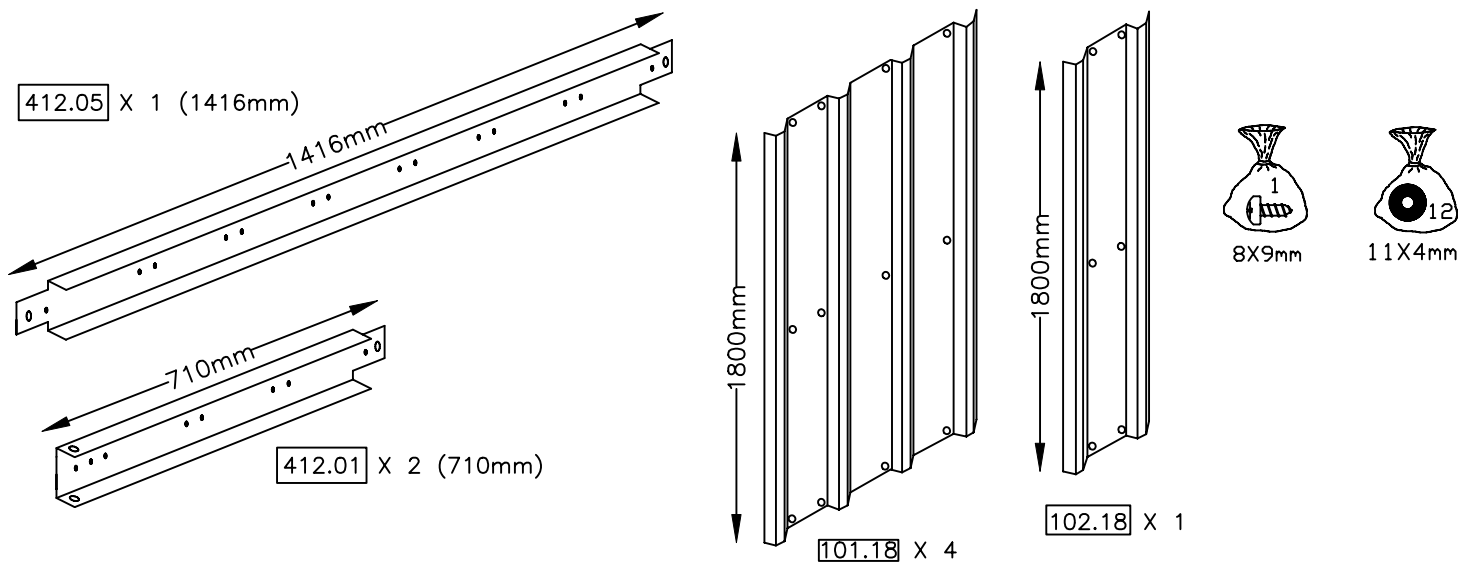

### BACK SECTION ASSEMBLY.

3. Fix left/right back braces; 41201, and intermediate back brace; 41205 to centre hole in standard upright; 41301.
4. Fit a 10118 wall panel to side of back section; starting from position:  
 : 4th hole from edge of base rail,  
 : 3rd hole along L/R back brace,  
 using screws (bag 1) and washers (bag 12).
5. Fit a further 10118 wall panel followed by a 10218 wall panel in centre of section followed by two further 10118 panels. Secure with screws and washers (bags 1 & 12) to complete back section.

### ASSEMBLAGE DE LA STRUCTURE ARRIERE

3. FIXER LES CONTREVENTEMENTS ARRIERES GAUCHE/DROIT, 41201 ET CONTREVENTEMENT CENTRALE ARRIERE, 41205 AU TROU CENTRAL DANS LE MONTANT SRANDARD, 41301.
4. FIXER LES PANNEAUX MURAUX (101.18) A LA STRUCTURE DE PROFILE ARRIERE COMME SUIT:  
 - 4 EME TROU DU BOUT DU RAIL BASE,  
 - 3 EME TROU SUR LE PROFILE LATERAL ARRIERE,  
 A L'AIDE DE LA VISSERIE DE LA POCHETTE NO.1 ET LES RONDELLES DE LA POCHETTE NO.12.
5. LE RECOUVEREMENT DES PANNEAUX 10118 ET 10218 DOIT ETRE FAIT SUIVANT LE SCHEMA CI-DESSOUS, AVEC LES VIS (POCHETTE NO. 1) ET LES RONDELLES DE LA POCHETTE NO. 12, EN COMMENCANT PAR LE BAS.

STEP 7 BACK PANEL ASSEMBLY / ASSEMBLAGE DE LA STRUCTURE ARRIERE

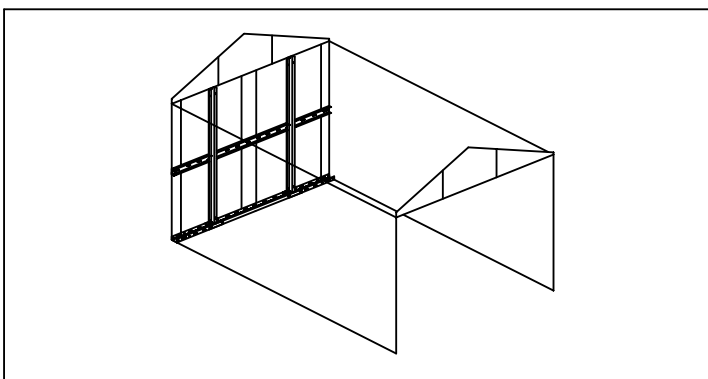
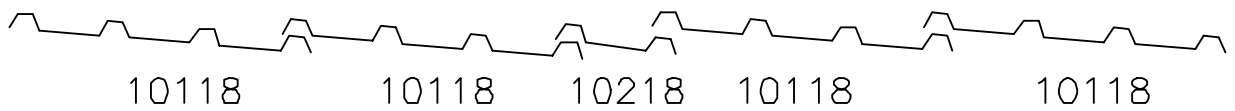
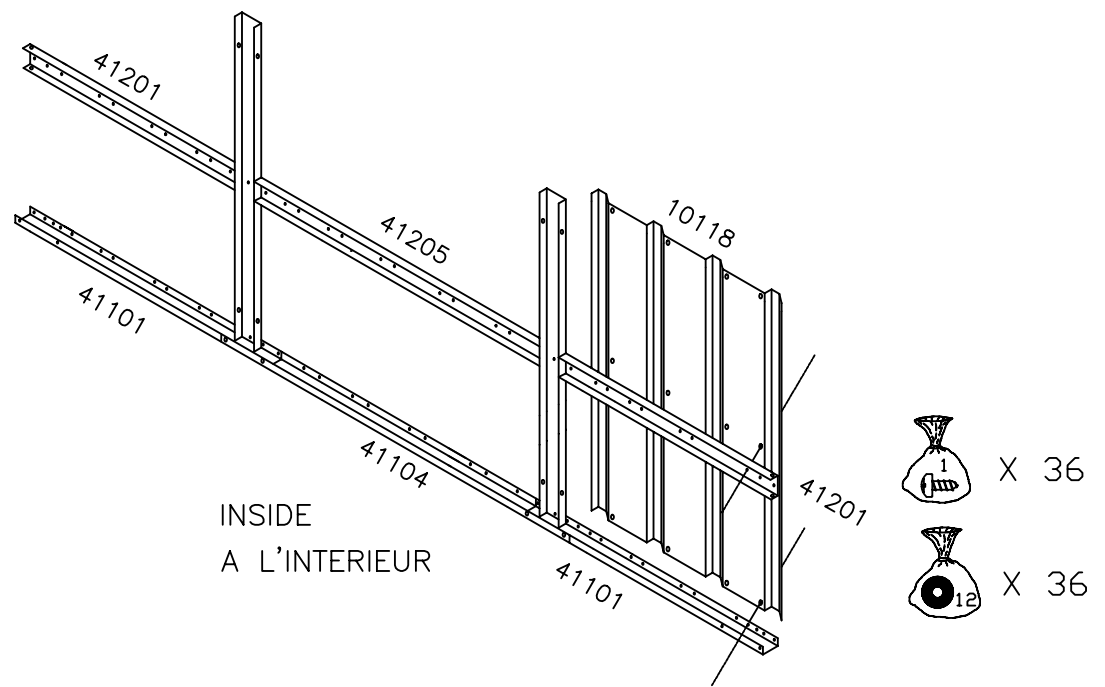
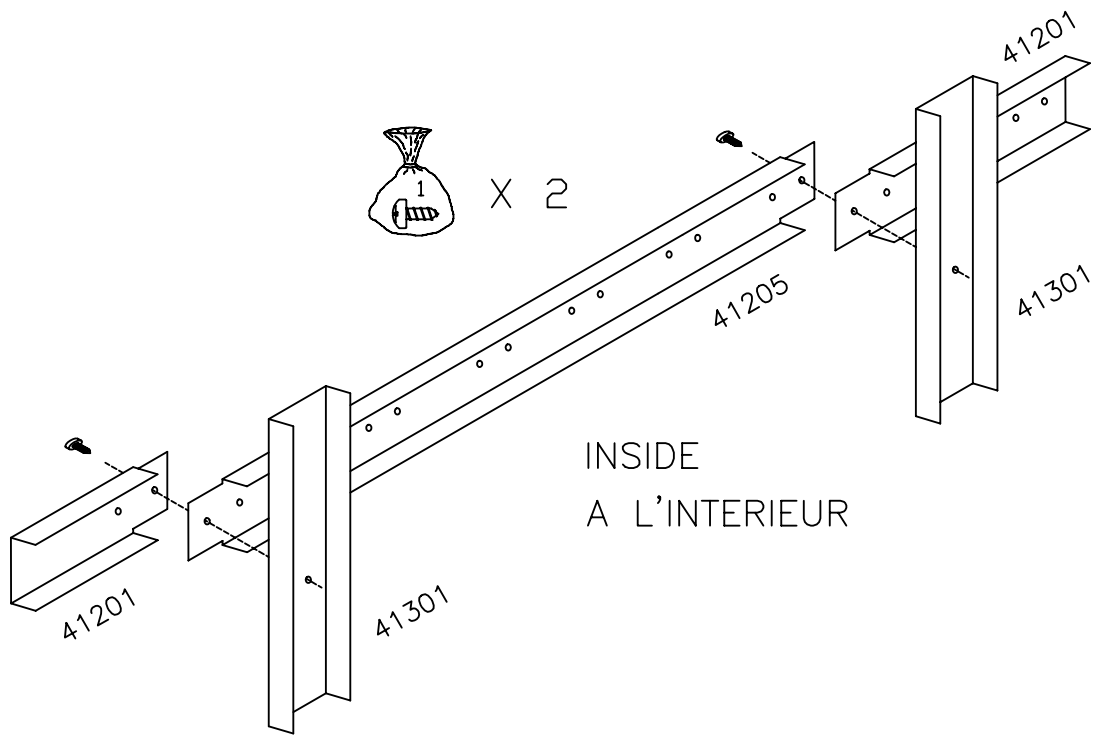

**STEP 8** BACK RIGHT SIDE SECTION / STRUCTURE ARRIERE DROITE  
 BACK LEFT SIDE SECTION / STRUCTURE ARRIERE GAUCHE

413.01 X 2 (1800mm)

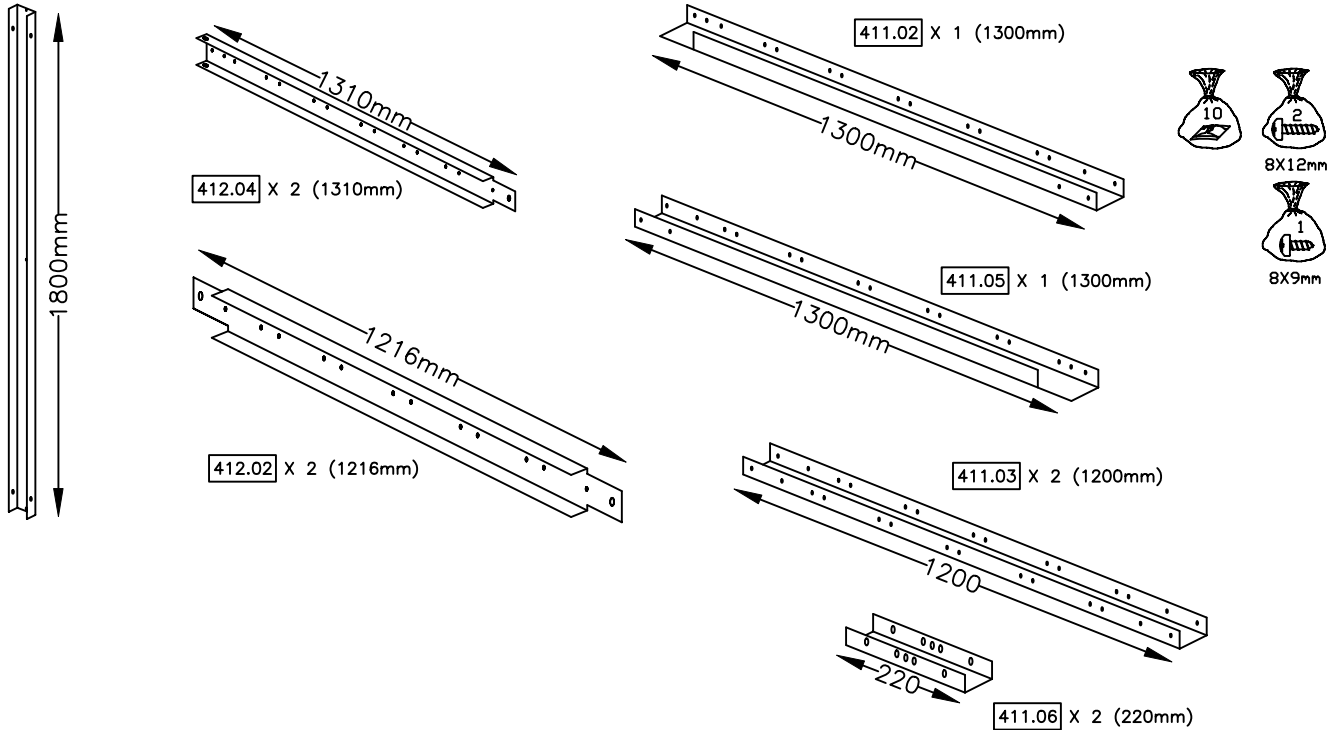

**BACK RIGHT SIDE SECTION**

1. Place base rails 41102, 41103 and base rail splice 41106 as shown and fix with screws (bag 1).
2. Fix standard upright post; 41301, at centre of base rail splice 41106 using screws (bag 2) and spire nuts (bag 10).
3. Attach right back side brace; 41204 and intermediate side brace; 41202, to standard upright as shown using screws (bag 1).

**STRUCTURE ARRIERE DROITE**

1. SUPERPOSER LES RAILS DE BASE 41102, 41103 ET ENTURE RAIL BASE 41106 COMME INDIQUE CI-DESSOUS, ET FIXER AVEC LES VIS DE LA POCHETTE NO. 1.
2. FIXER PAR SUPERPOSITION LES PROFILES D'ANGLE 41301 AU CENTRE DU RAIL BASE ARRIERE 41106 A L'AIDE DE LA VISSERIE DE LA POCHETTE N0.2, ET LES ECROUS DE LA POCHETTE NO. 10.
3. ASSEMBLER LE PROFILE ARRIERE DROIT 41204 ET LE PROFILE LATERAL DE COTE 41202 AU MONTANT STANDARD 41301 COMME INDIQUE CI-DESSOUS, A L'AIDE DE LA VISSERIE DE LA POCHETTE NO. 1.

# STEP 8 BACK RIGHT SIDE SECTION / STRUCTURE ARRIERE DROITE

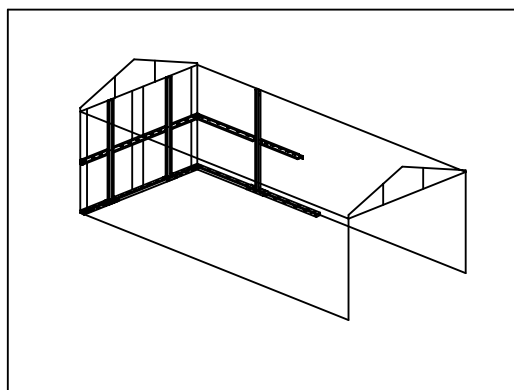
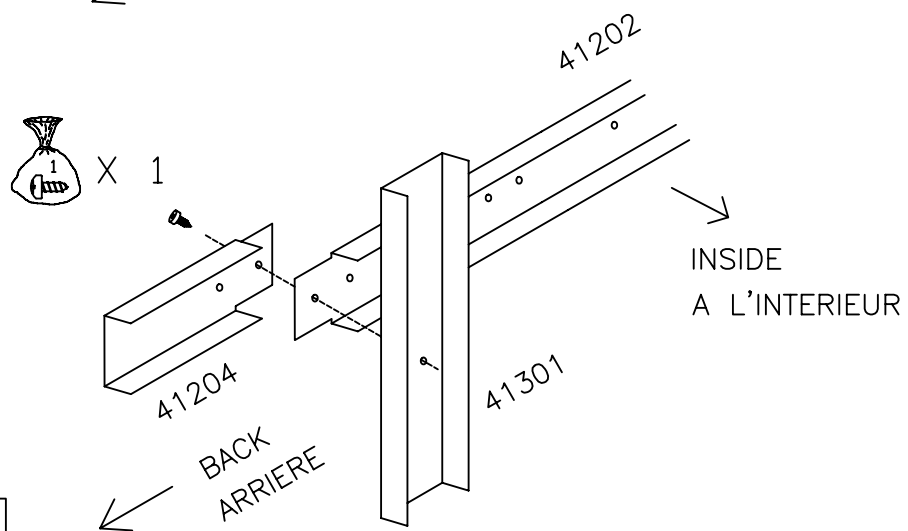
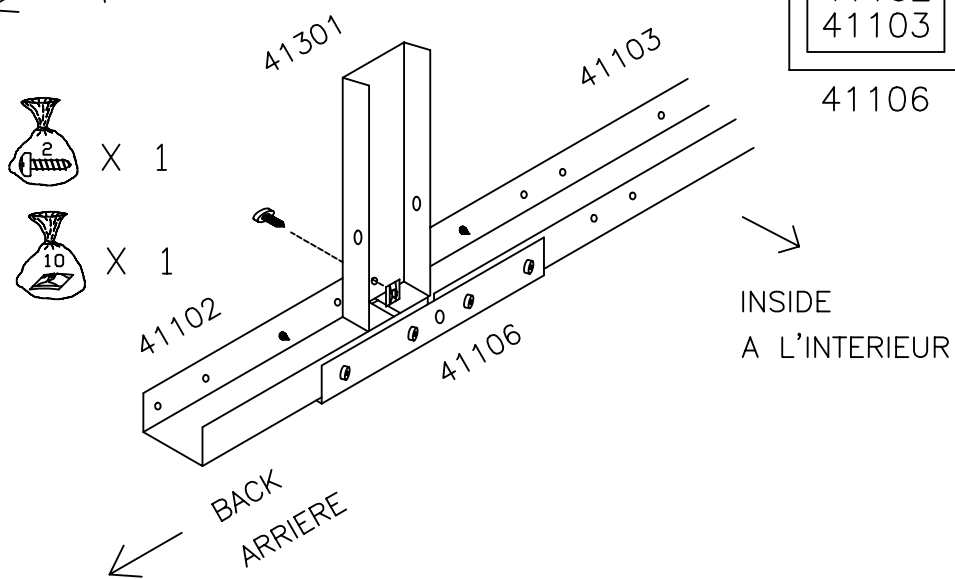
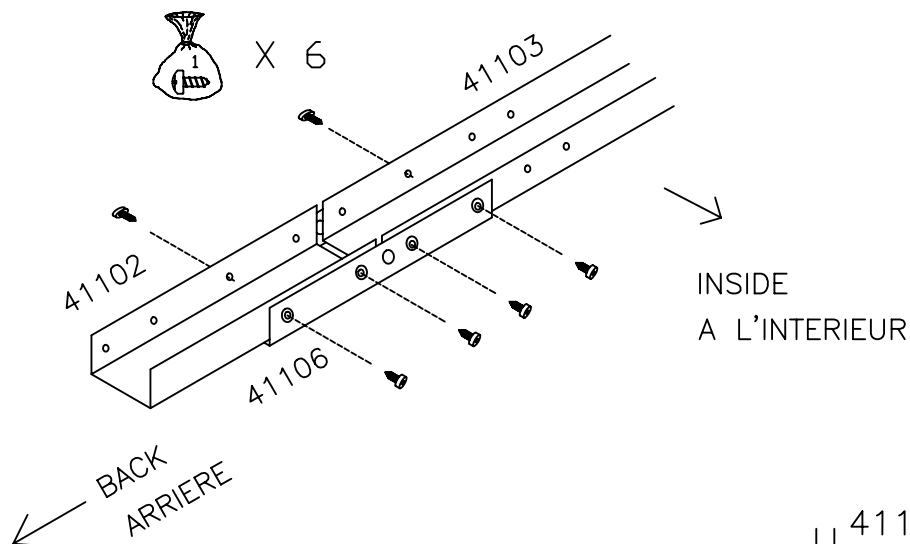
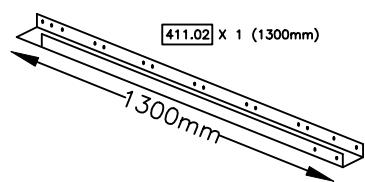



# STEP 8 BACK LEFT SIDE SECTION / STRUCTURE ARRIERE GAUCHE

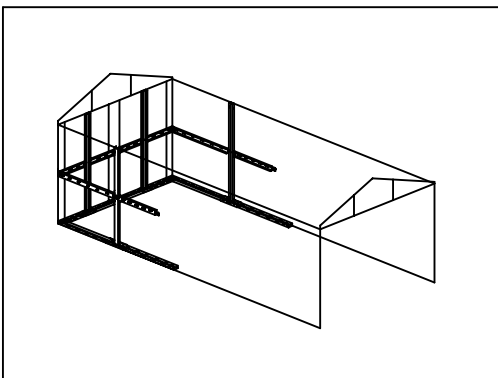
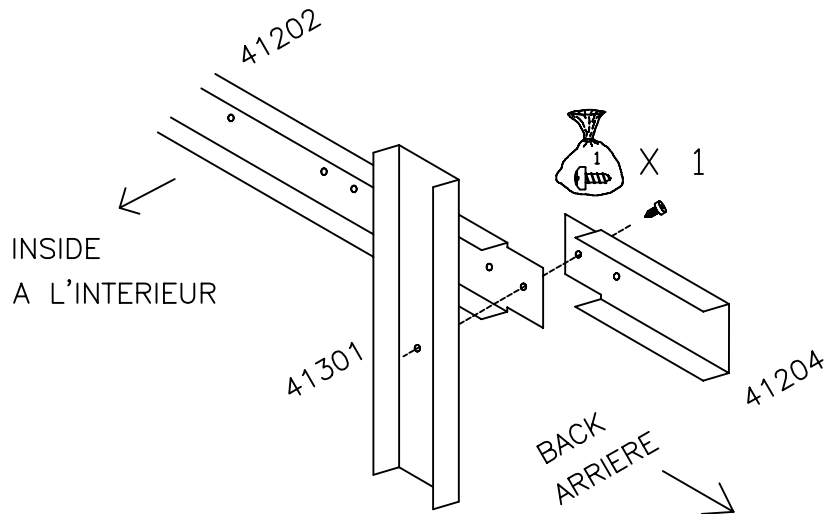
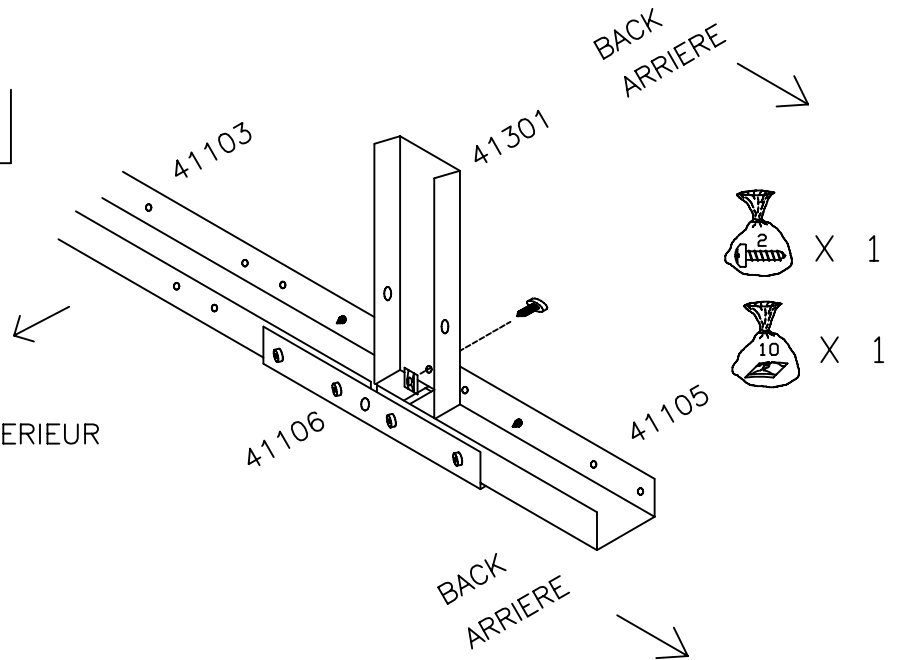
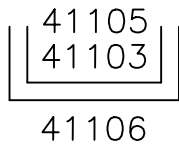
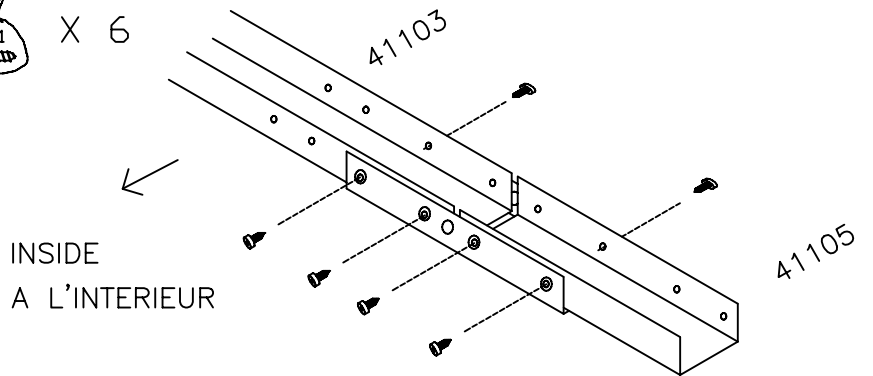
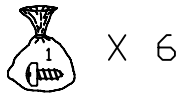
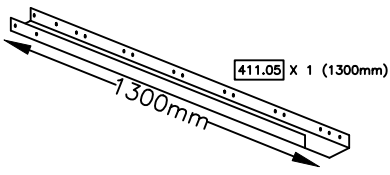

## STEP 8

BACK RIGHT SIDE SECTION / STRUCTURE ARRIERE DROITE  
BACK LEFT SIDE SECTION / STRUCTURE ARRIERE GAUCHE

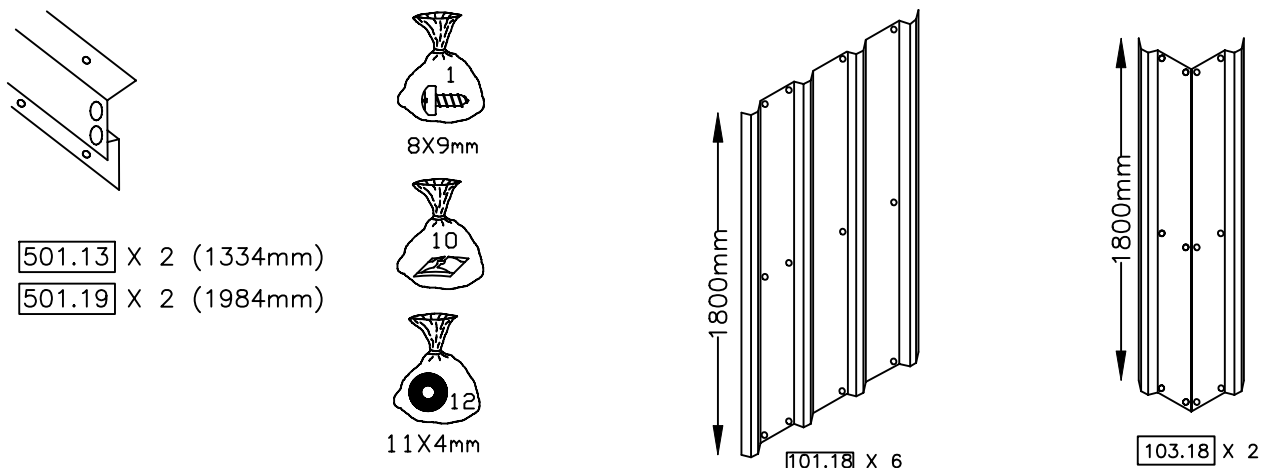

### BACK RIGHT SIDE SECTION

4. Overlap sidebeams; 50119 and 50113 as shown using 4 screws (bag 1).  
**N.B.** These may have to be removed later to facilitate fitting wall panels !!!
5. Fix spliced sidebeam to standard upright; 41301 as shown with screws (bag 1) and spire clips (bag 10), 1300mm from notched edge of 50119.
6. Fix 10318 corner panel to edge of back right section as shown using screws (bag1) and washers (bag 12).
7. Fix three 10118 wall panels, starting at corner panel with screws (bag 1) and washers (bag 12).

**REPEAT STEPS 1-7 FOR OPPOSITE SIDE (BACK LEFT) USING SIDE RH FRONT/LH REAR BASE RAIL 41105 INSTEAD OF 41102.**

### STRUCTURE ARRIERE DROITE

4. SUPEROSER ET VISSER LES POUTRE DU COTE 50113 ET 50119, A L'AIDE DE 4 VIS DE LA POCHETTE NO.1.
- NOTA:** CES 4 VIS DEVRONT ETRE DEVISSEES PLUS TARD POUR FIXER LES PANNEAUX MURAUX.
5. FIXER LES POUTRES DE COTE AU MONTANT STANDARD 41301 COMME INDIQUE CI-DESSOUS A 1300 MM DU FIL ENTAILLE, A L'AIDE DE LA VISSERIE DE LA POCHETTE NO.1 ET LES EROUS DE LA POCHETTE NO.10.
  6. FIXER LE PANNEAU D'ANGLE (103.18) AU PROFILE ARRIERE DROIT COMME INDIQUE CI-DESSOUS, A L'AIDE DE LA VISSERIE DE LA POCHETTE NO.1 DES RONDELLES EN FIBRE DE LA POCHETTE NO.12.
  7. FIXER LES PANNEAUX MURAUX 10118 EN PARTANT DU PANNEAU D'ANGLE ET EN UTILISANT LA VISSERIE DE LA POCHETTE NO.1 ET LES RONDELLES EN FIBRE DE LA POCHETTE NO.12.

**MEME MONTAGE DE 1 A 7 POUR LE COTE OPPOSE ARRIERE GAUCHE EN UTILISANT RAIL BASE LATERAL AVANT DROIT / ARRIERE GAUCHE 41105 AU LIEU DE 41102.**

STEP 8 BACK RIGHT SIDE SECTION / STRUCTURE ARRIERE DROITE

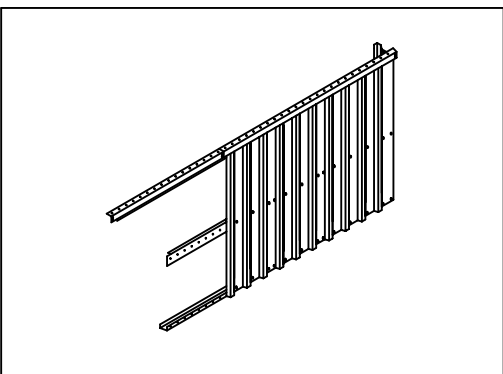
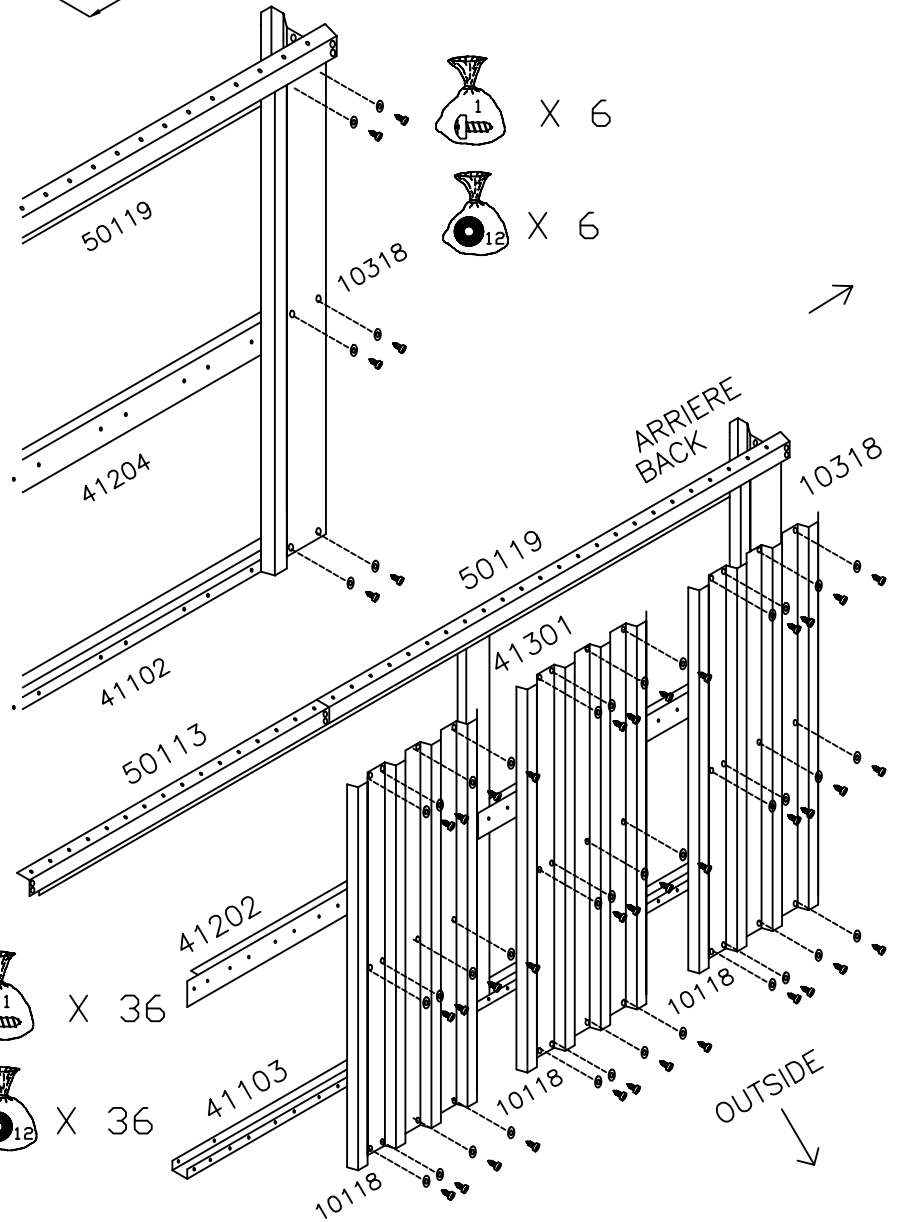
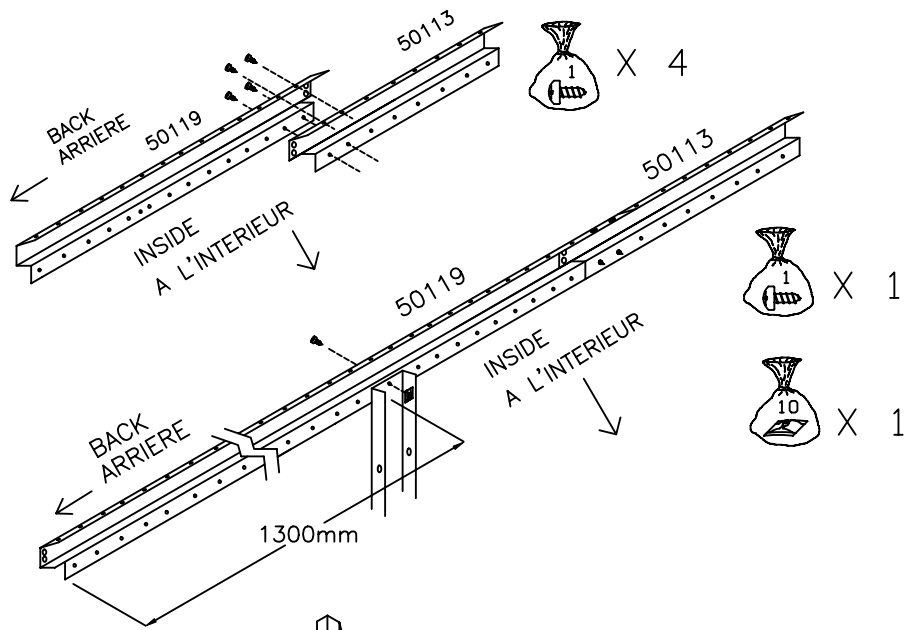

1 X 36

12 X 36

# STEP 8 BACK LEFT SIDE SECTION / STRUCTURE ARRIERE GAUCHE

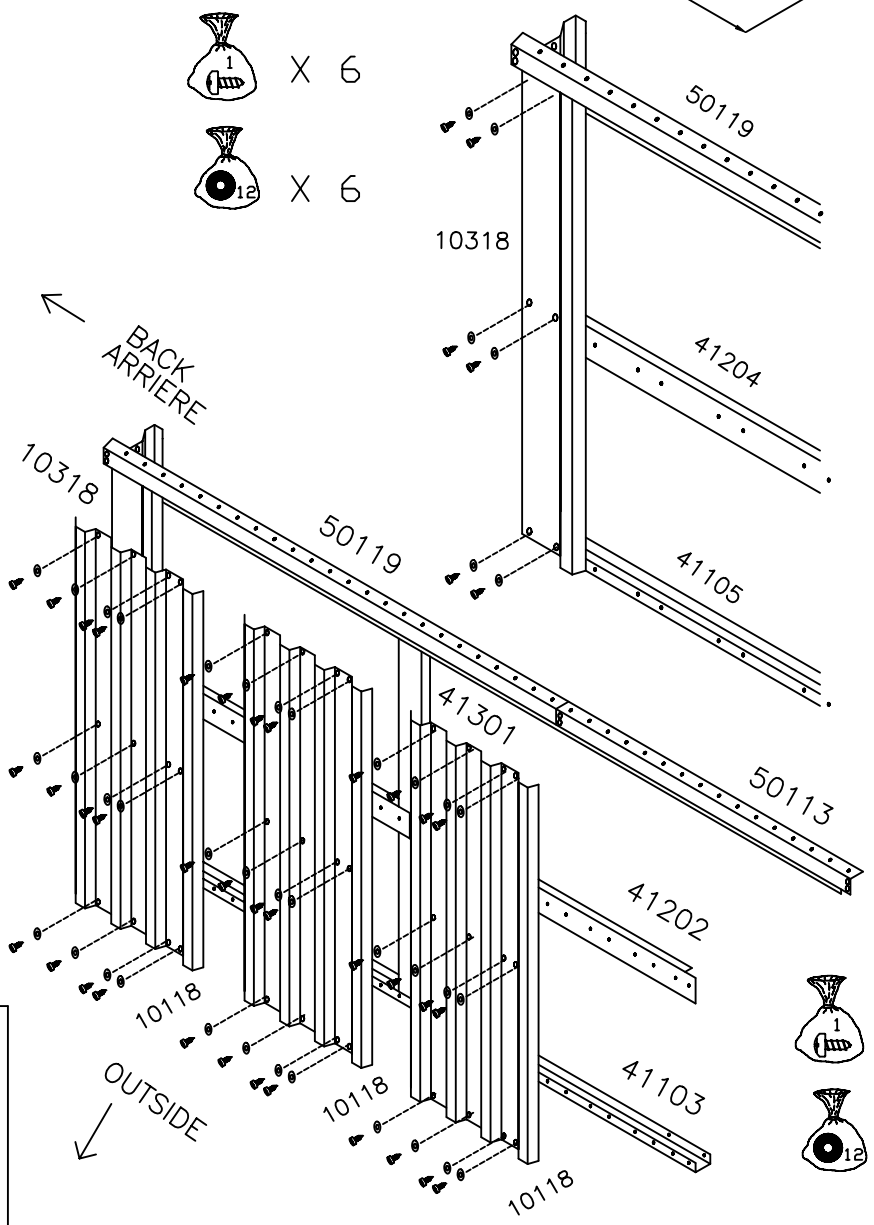
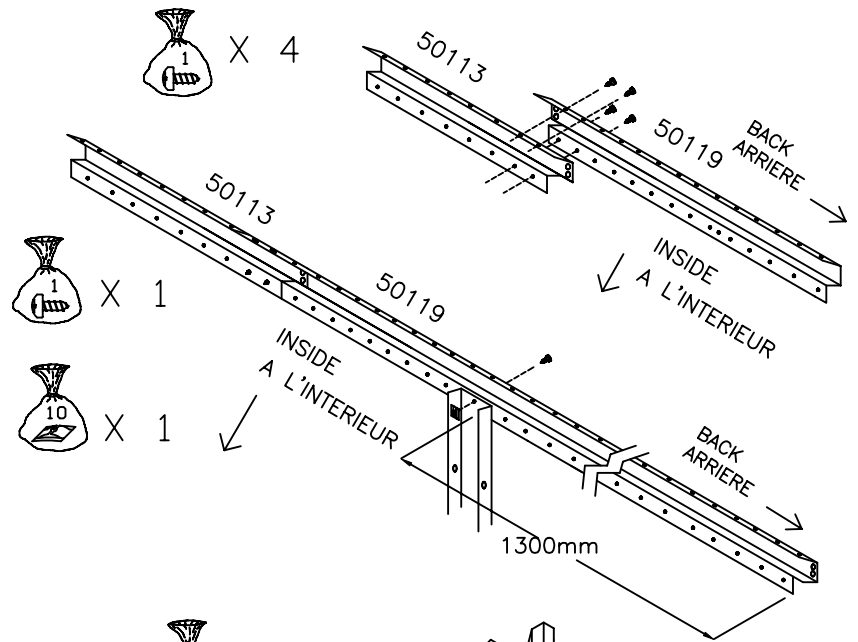
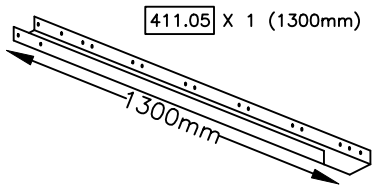

- X 36
- X 36

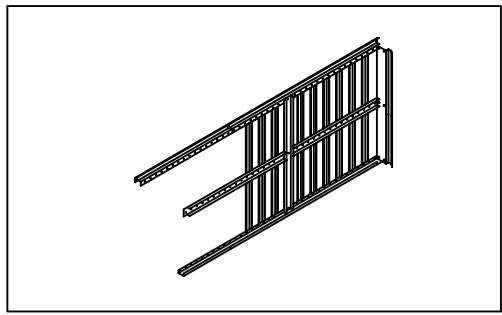

STEP 9 FRONT RIGHT SIDE SECTION / STRUCTURE AVANT DROIT  
FRONT LEFT SIDE SECTION / STRUCTURE AVANT GAUCHE

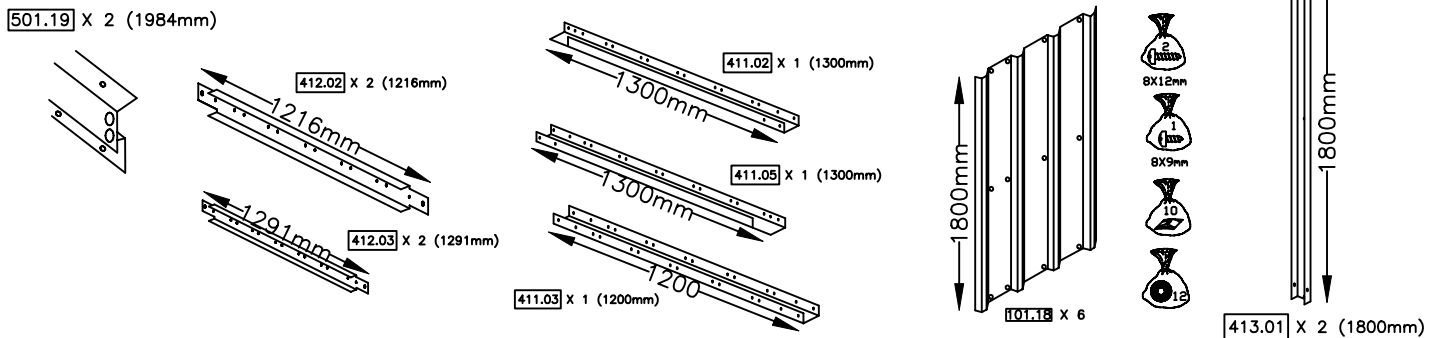

**FRONT RIGHT SIDE SECTION**

1. Position base rails; 41105, 41103 and side base rail splice 41106 as shown and fix with screws (bag 1).
2. Fix standard upright to centre of base rail splice 41106 using screws (bag 2) and spire nuts (bag 10).
3. Fix front right side brace; 41203 and intermediate side brace; 41202, to centre hole in standard upright 41301 using a screw (bag 1).
4. Fix sidebeam 50119 to standard upright 41301 (through hole 1300mm from front notched edge of 50119) using screws (bag 1) and spire clips (bag 10).
5. Fix three 10118 wall panels starting in position;  
3rd hole from front of base rail.  
3rd hole from front of side brace.

**REPEAT STEPS FOR OPPOSITE SIDE (FRONT LEFT) USING SIDE LH FRONT /RH REAR BASE RAIL 41102 INSTEAD OF 41105.**

**STRUCTURE AVANT DROIT**

1. POSITIONNER LES RAILS DE BASE 41105, 41103 ET ENTURE DU RAIL BASE LATERAL 41106 COMME INDIQUE CI-DESSOUS, ET FIXER AVEC LES VIS DE LA POCHETTE NO.1. ET LES RONDELLES DE LA POCHETTE NO.12.
2. FIXER LE MONTANT STANDARD 41301 AU CENTRE LES PROFILS D'ANGLE DE PILIER A L'AIDE DE LA VISSERIE DE LA POCHETTE NO.2, ET LES ECROUS DE LA POCHETTE NO.10.
3. ASSEMBLER LE PROFILE AVANT DROIT 41203 ET LE PROFILE LATERAL DE COTE 41202 AU MONTANT STANARD 41301 COMME INDIQUE CI-DESSOUS, A L'AIDE DE LA VISSERIE DE LA POCHETTE NO.1.
4. FIXER LA POUTRE DE COTE 50119 PAR LE TROU SPECIAL, AU MONTANT STANDARD DANS LE TROU A 1300MM DU FIL ENTAILLE.
5. FIXER LES PANNEAUX MARAUX (101.18) COMME SUIT:  
- 4 EME TROU DE L'AVANT DU RAIL BASE,  
- 3 EME TROU DE L'AVANT DU CONTREVENTEMENT LATERALE.

**IDEM POUR MONTAGE STRUCTURE OPPOSE GAUCHE EN UTILISANT RAIL BASE LATERALE AVANT GAUCHE/ ARRIERE DROIT 41102 AU LIEU DE 41105**

STEP 9 FRONT RIGHT SIDE SECTION / STRUCTURE AVANT DROIT

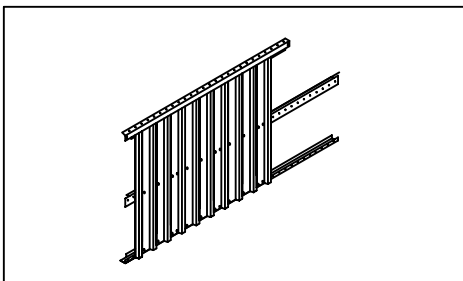
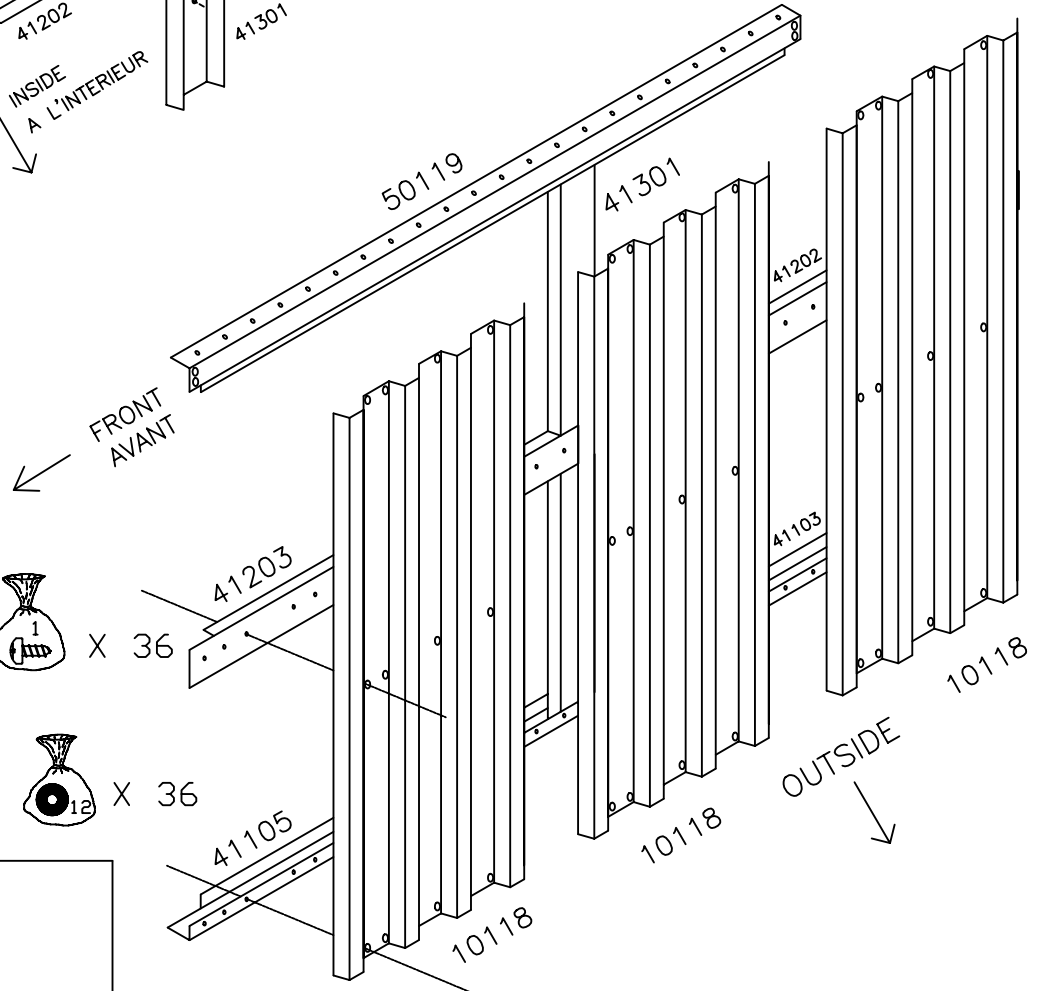
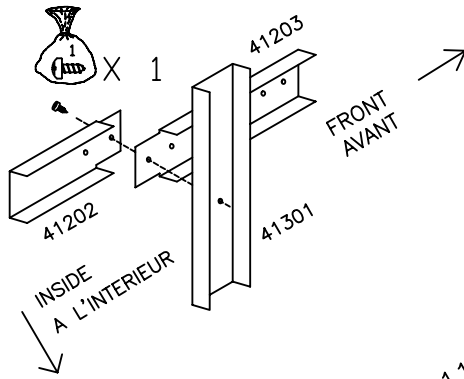
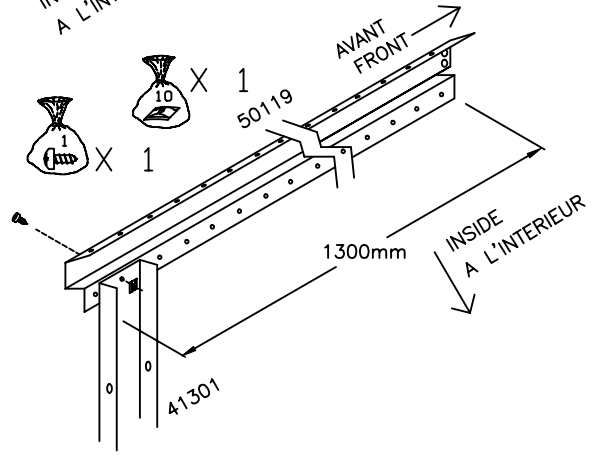
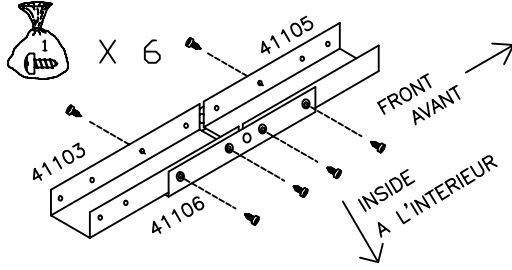
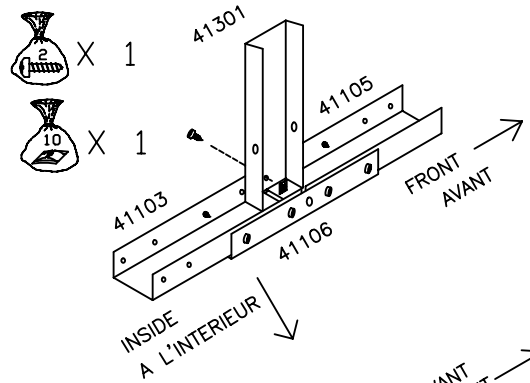
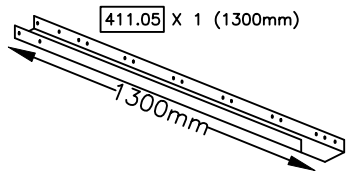

STEP 9 FRONT LEFT SIDE SECTION / STRUCTURE AVANT GAUCHE

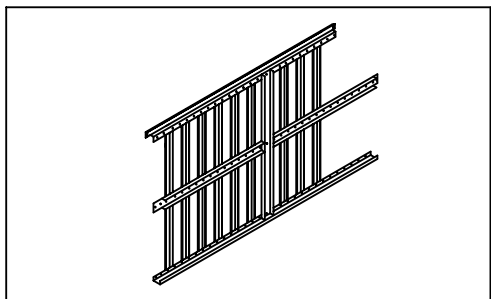
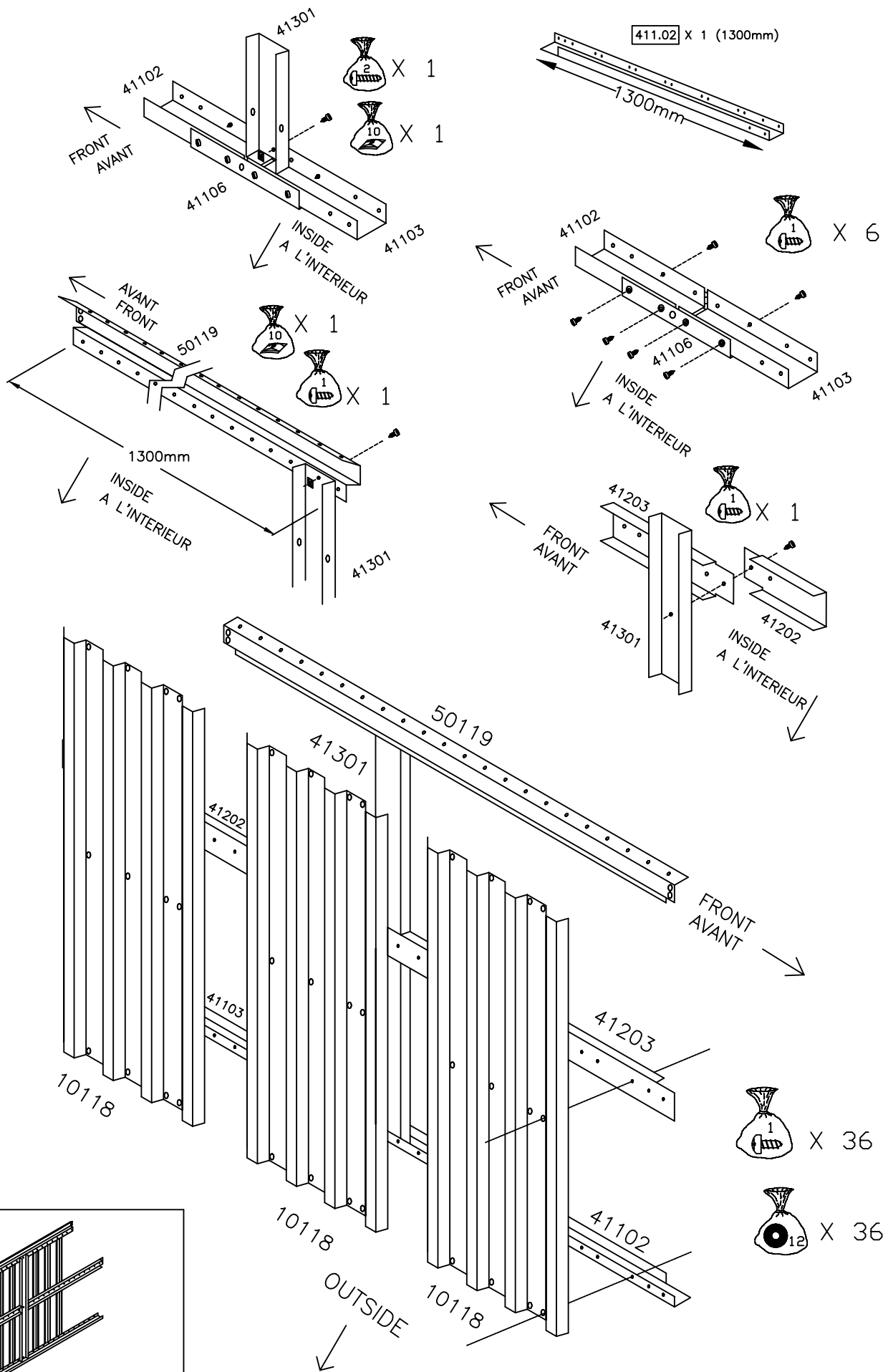

## STEP 10 STRUCTURE ASSEMBLY / ASSEMBLAGE DE LA STRUCTURE

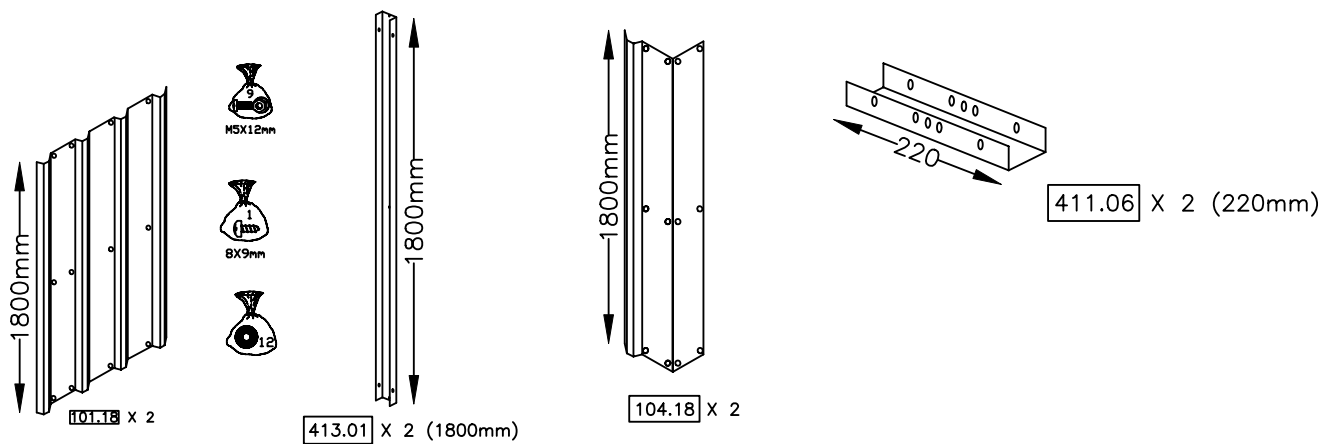

### STRUCTURE ASSEMBLY

1. Raise back section and fix right back section at base rails with screws (bag 1). Secure side and back braces with bolts and nuts (bag 9).
2. Raise back left side and fix to back section in same manner.

**ALWAYS ENSURE SQUARENESS IN STRUCTURE ASSEMBLY.**

3. Raise front right section and secure intermediate base rails; 41103's using base rail splice 41106. Screw together sidebeams at top on two aligning holes (these screws may also need to be removed to facilitate fixing roof panels).
4. Locate together; standard upright 41301 and two notched intermediate side braces 41202 at center hole and fix. Attach two 10118 wall panels using screws (bag 1) and washers (bag 12).

**REPEAT FOR FRONT LEFT SECTION.**

### ASSEMBLAGE DE LA STRUCTURE

1. DRESSER LA STRUCTURE ARRIERE ET LA FIXER AU PROFILE ARRIERE DROIT, AU RAIL DE BASE (POCHETTE NO.1&NO.12) ET AU PROFILE LATERAL, AVEC DES BOULONS DE 5MM DE LA POCHETTE N0.9.
2. DE LA MEME MANIERE, FIXER LE PROFILE ARRIERE GAUCHE AU RAIL DE BASE ET AU PROFILE LATERAL.

**S'ASSURER TOUJOURS DE LA RECTITUDE DE LA STRUCTURE**

3. PRESENTER LA STRUCTURE DU COTE DROIT ET LA FIXER AU RAIL DE BASE DE COTE 41103 EN UTILISANT LES ENTURES RAIL BASE 41106. VISSER ENSEMBLE LES POUTRES DE COTE DANS LES DEUX TROUS (LES DEUX VIS DEVRONT ETRE DEVISSEES POUR FACILITER LA FIXATION DES PANNEAUX DE TOIT).
4. ASSEMBLER LES MONTANTS STANDARD 41301, LES DEUX PROFILS LATERAUX ENTAILLES DE COTE 41202 AU TROU CENTRAL ET FIXER.

REPETER POUR LA STRUCTURE AVANT GAUCHE.



STEP 10 STRUCTURE ASSEMBLY / ASSEMBLAGE DE LA STRUCTURE

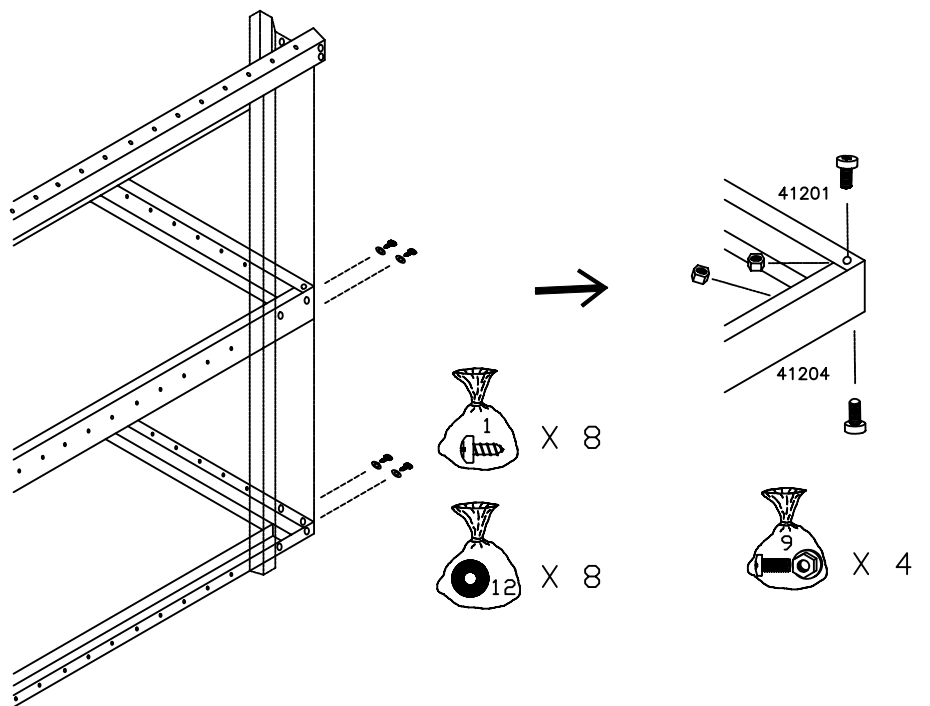
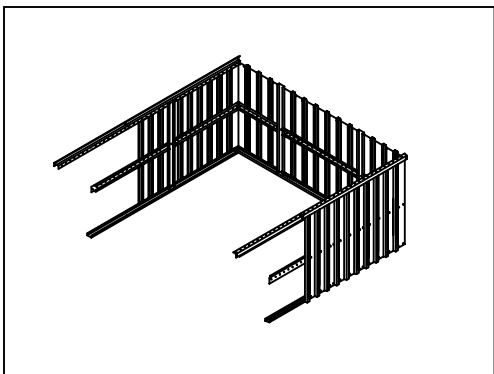
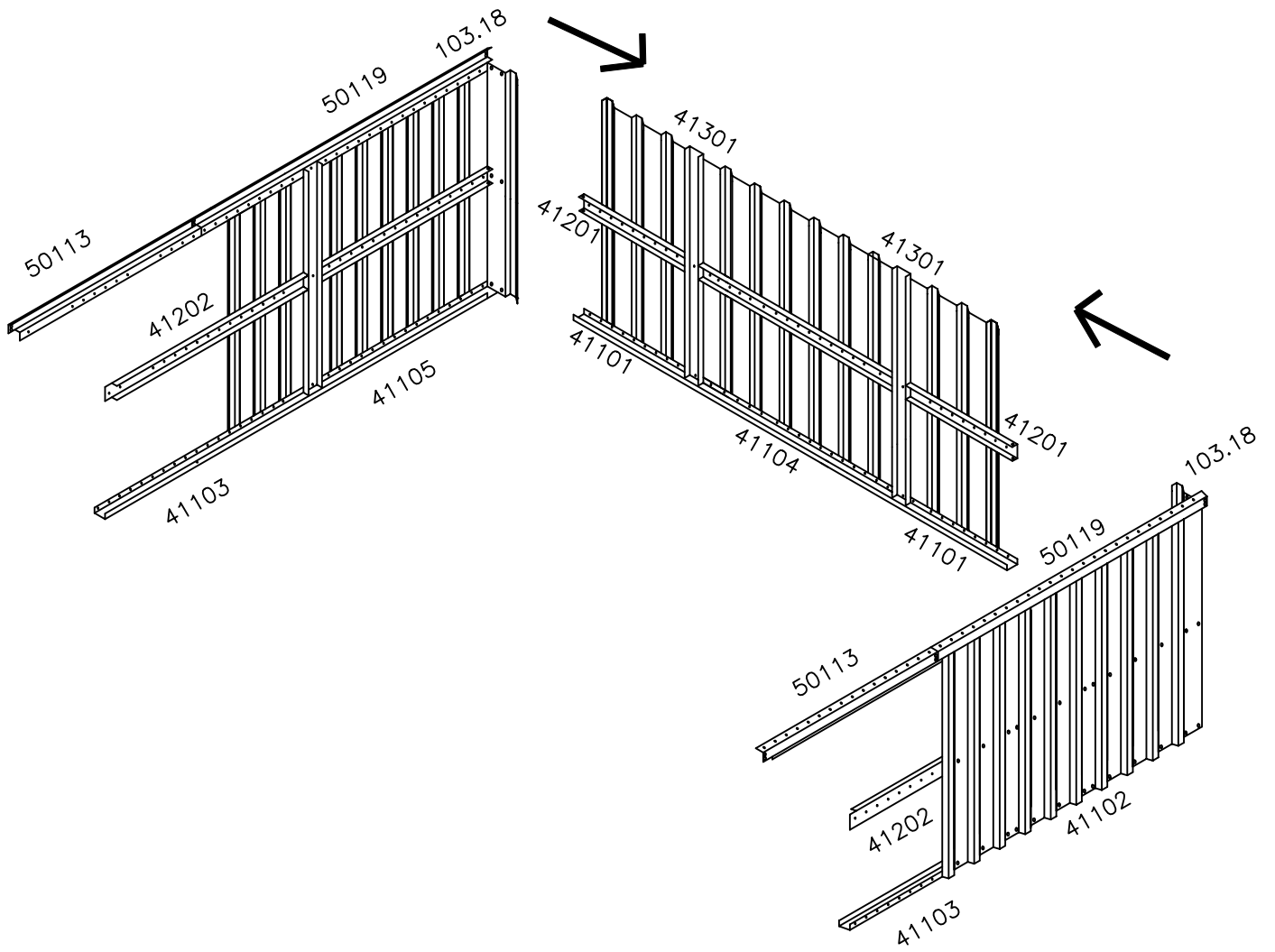

# STEP 10

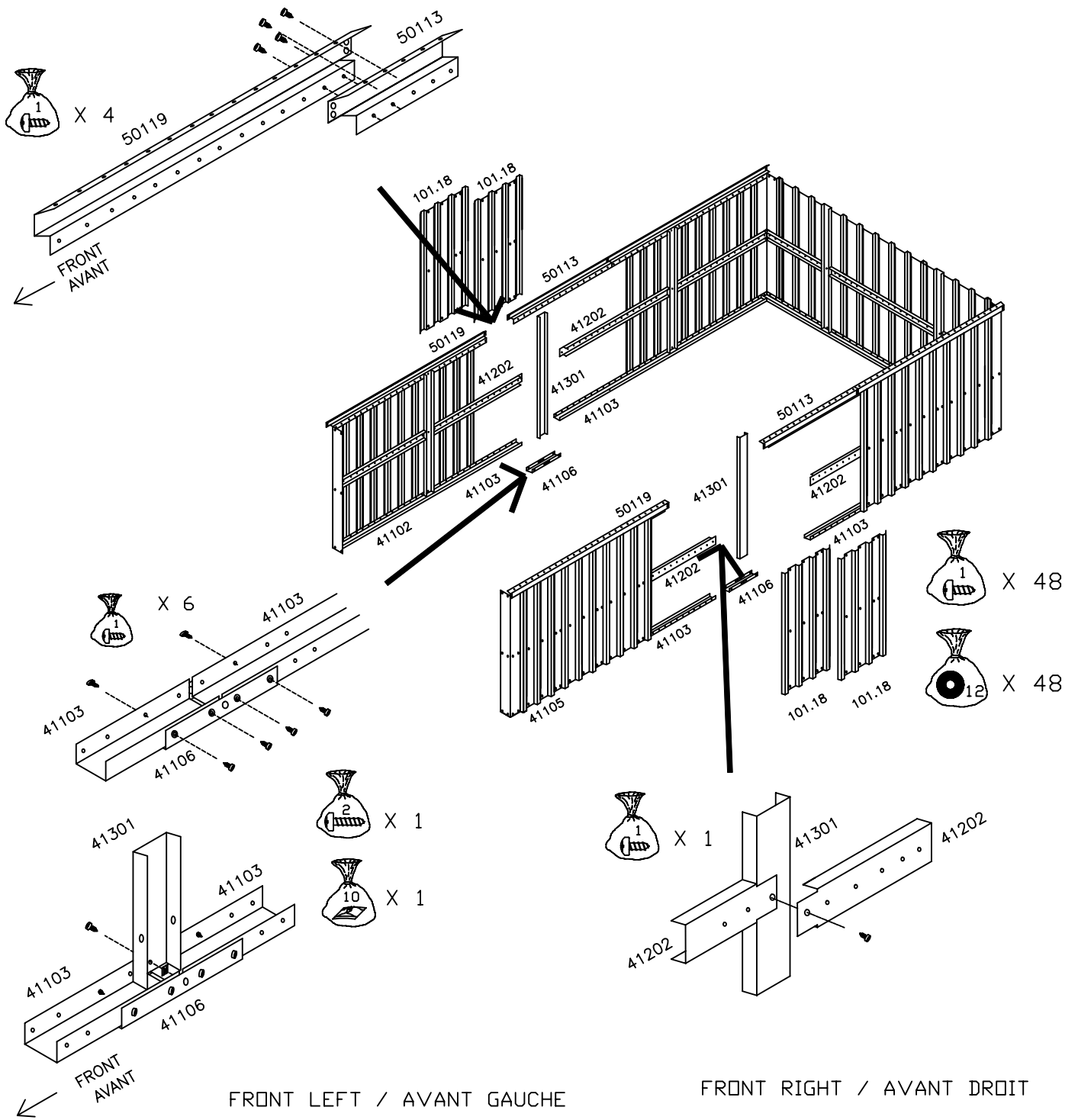

## STEP 11 STRUCTURE ASSEMBLY / ASSEMBLAGE DE LA STRUCTURE

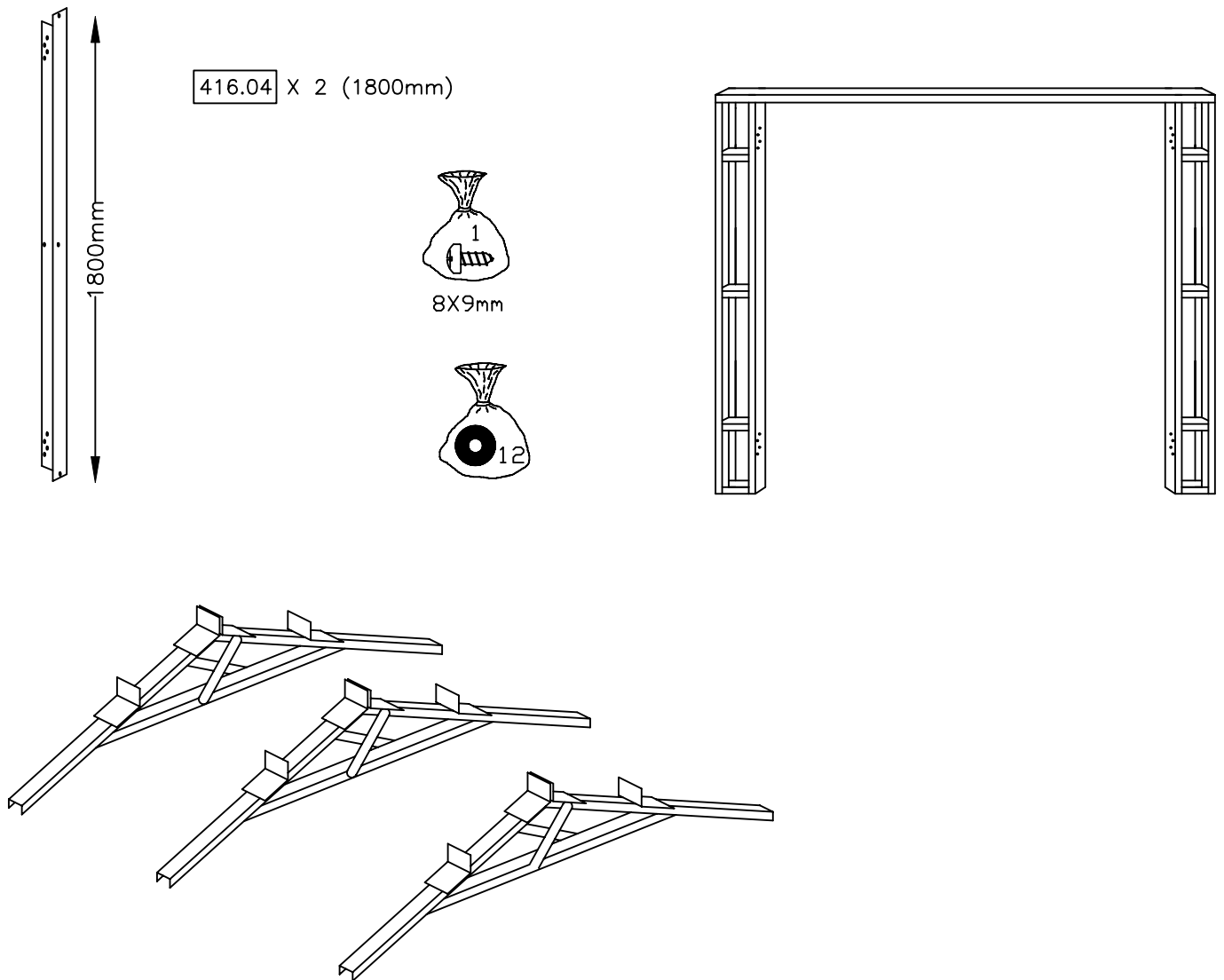

### STRUCTURE ASSEMBLY

5. Fix front frame assembly to garage frame and corner panel with screws (bag 1) and washers (bag 12).
6. Fix roof truss sub-assemblies to all three opposite pairs of standard uprights.
7. Fix front frame angles, 41604 to front frame and corner panel attachment, using screws (bag 1) and washers (bag 12) as shown.

### ASSEMBLAGE DE LA STRUCTURE

5. ASSEMBLER LA STRUCTURE AVANT, LES PROFILS DE COTE DU GARAGE ET LES PANNEAUX D'ANGLE, AVEC LA VISSERIE DE LA POCHETTE NO.1 ET LES RONDELLES DE POCHETTE NO.12.
6. ASSEMBLER LA STRUCTURE DE TOIT SUR LES MONTANTS STANDARDS.
7. FIXER LES ANGLES DE LA STRUCTURE AVANT 41604 A LA STRUCTURE AVANT ET L'ATTACHEMENT DU PANNEAU D'ANGLE, AVEC DES VIS (SAC 1) ET DES RONDELLES (SAC 12) COMME INDIQUE.

STEP 11 STRUCTURE ASSEMBLY / ASSEMBLAGE DE LA STRUCTURE

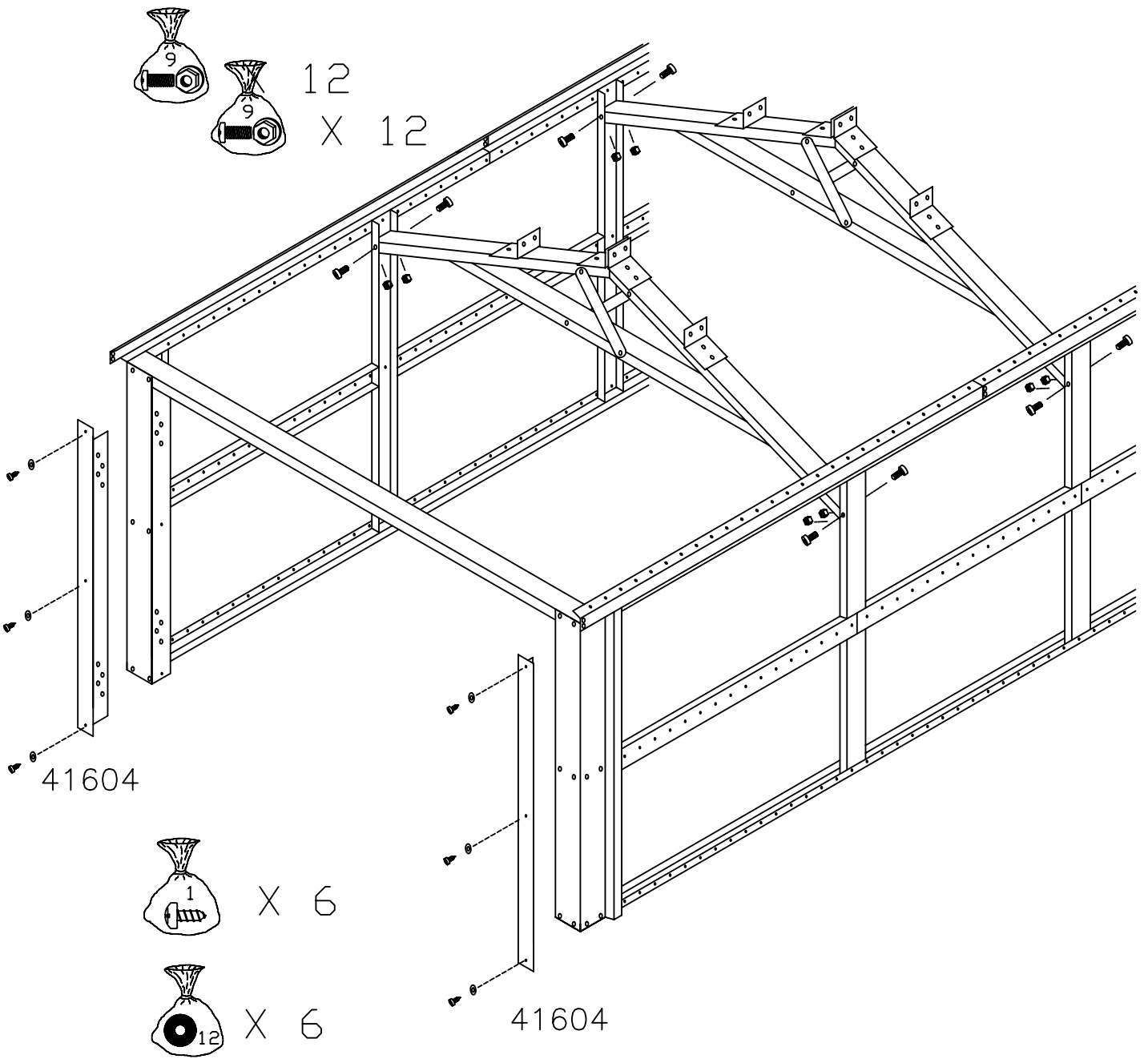

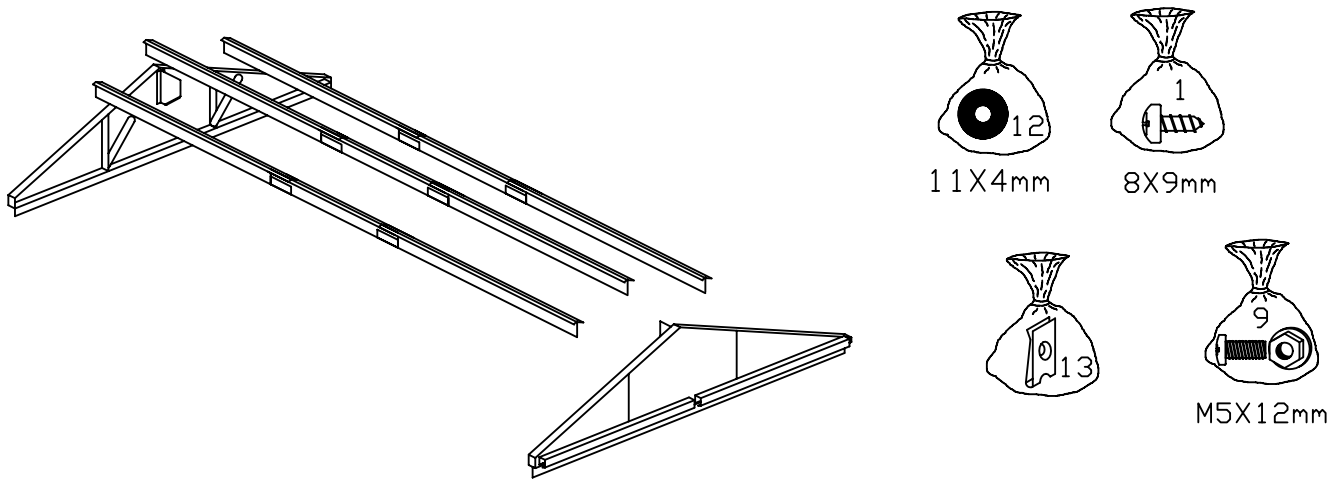

### ROOF FRAME ASSEMBLY

1. Fix left hand gable 301, right hand gable 302 and centre gable 305.3 to the wall panels at the back of the garage with screws (bag 1) and washers (bag 12) use double spire clips (bag 13) on bottom edge of gables as needed (where 2 x 7mm holes occur) . Fix sidebeam 50119 to each gable end using screws (bag 1) and washers (bag 12) (fig. 4).
2. Repeat for the front of the garage bag 13 not required.
3. Make available 3 sets of roof beams assembled earlier.
4. Fix one set of roof beams 502 to roof beam gussets 505 and 506 with bolts and nuts (bag 9). The sloping sides of the roof beam should be fitted under the gable flanges (fig. 5).
5. Fit roof beams 502 to roof beam support 50630, gables 301/302 and centre gables 305.3 with bolts and nuts (bag 9).
6. Fix roof beams to roof truss angles (roof truss angles fit between roof beams) with bolts and nuts (bag 9).

### ASSEMBLAGE DES PROFILS DE TOIT

1. FIXER LE PIGNON GAUCHE 301, LE PIGNON DROIT 302 ET LE PIGNON CENTRAL 305.3 AUX PANNEAUX MURAUX ARRIERES DU GARAGE, A L'AIDE DE LA VISSERIE (POCHETTE NO.1) ET DES RONDELLES DE LA POCHETTE NO.12. FIXER AUX EXTREMITES DES POUTRES DE COTE 50119 (FIGURE 4).
2. MEME OPERATION DE MONTAGE POUR LE DEVANT DU GARAGE .
3. PREPARER LES TROIS POUTRES MONTEES PLUS TOT.
4. FIXER LES POUTRES FAITIERES 502 AUX EQUERRES DE POUTRE 505 ET 506 AVEC LA VISSERIE DE LA POCHETTE NO.9. LES COTES INCLINES DE LA POUTRE DE TOIT DOIVENT ETRE FIXES EN DESSOUS DES REBORDS DES PIGNONS (FIGURE 5).
5. ASSEMBLER LES POUTRES DE TOIT 502 AU SUPPORT DE TOIT 50360 ET AUX PIGNONS 301, 302 ET 305.3 A L'AIDE DES BOULONS ET ECROUS DE LA POCHETTE NO.9. LES COTES INCLINES DE LA POUTRE DE TOIT DOIVENT ETRE FIXES AU DESSUS DU REBORD DES PIGNONS 301 ET 302 ET EN DESSOUS DU REBORD DU PIGNON CENTRAL 305.3.
6. FIXER LES EQUERRES DE TOIT AUX POUTRES D'ANGLE RENFORCEES AVEC LES BOULONS DE LA POCHETTE NO. 9.

STEP 12 ROOF FRAME ASSEMBLY / ASSEMBLAGE DES PROFILS DE TOIT

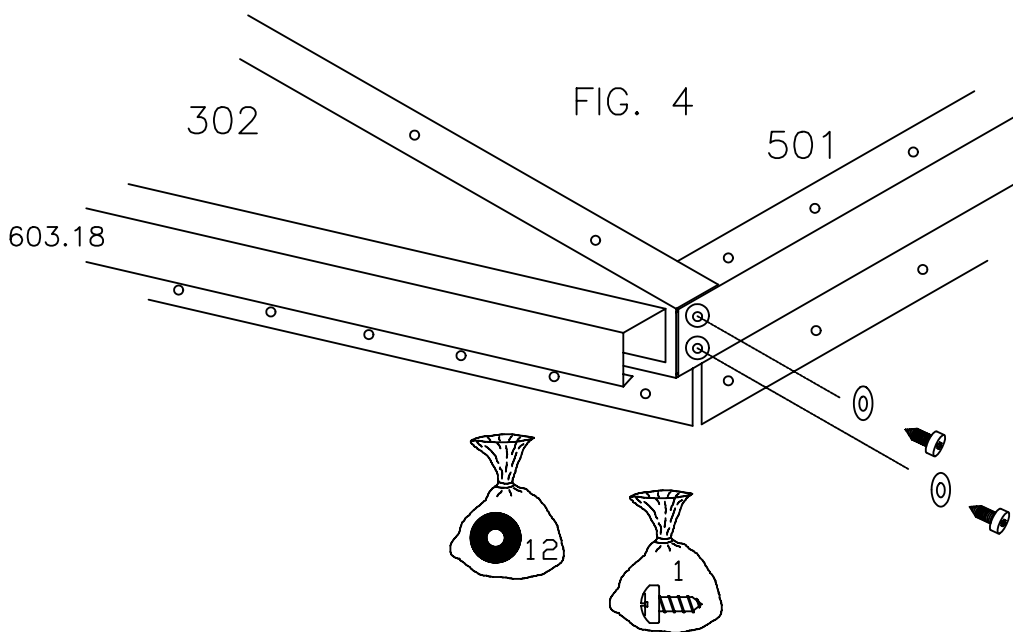
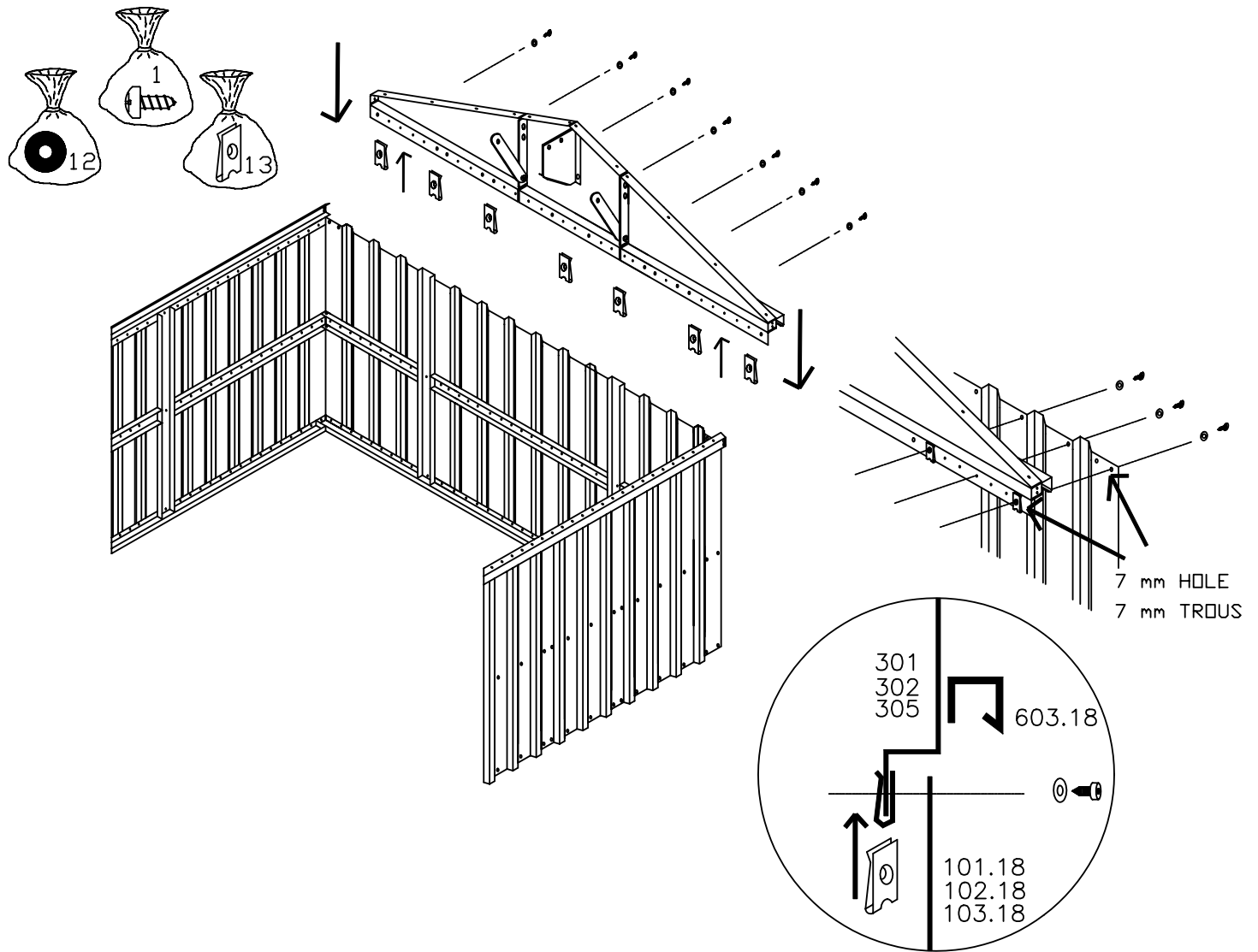

STEP 12 ROOF FRAME ASSEMBLY / ASSEMBLAGE DES PROFILES DE TOIT

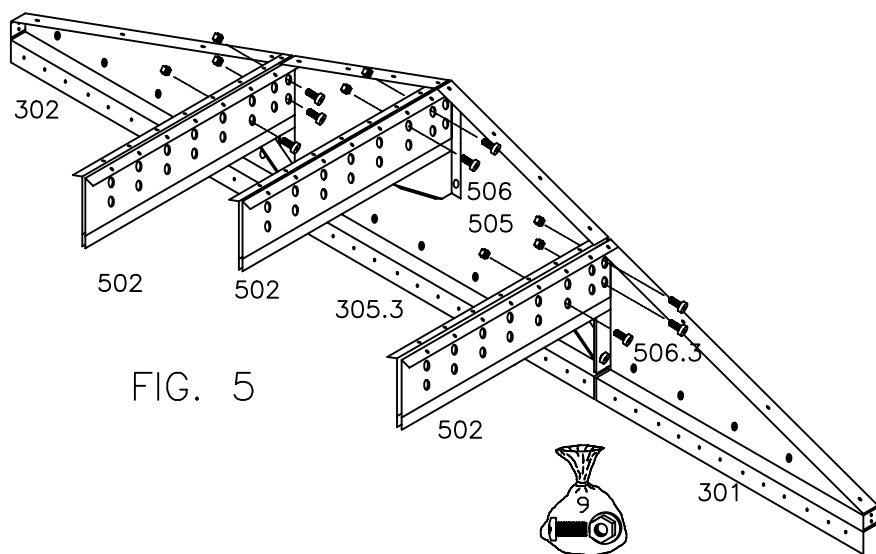
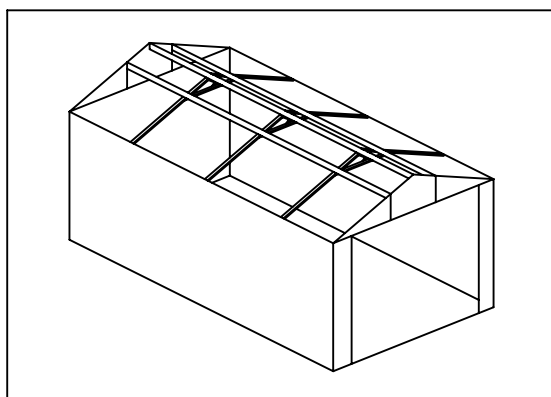
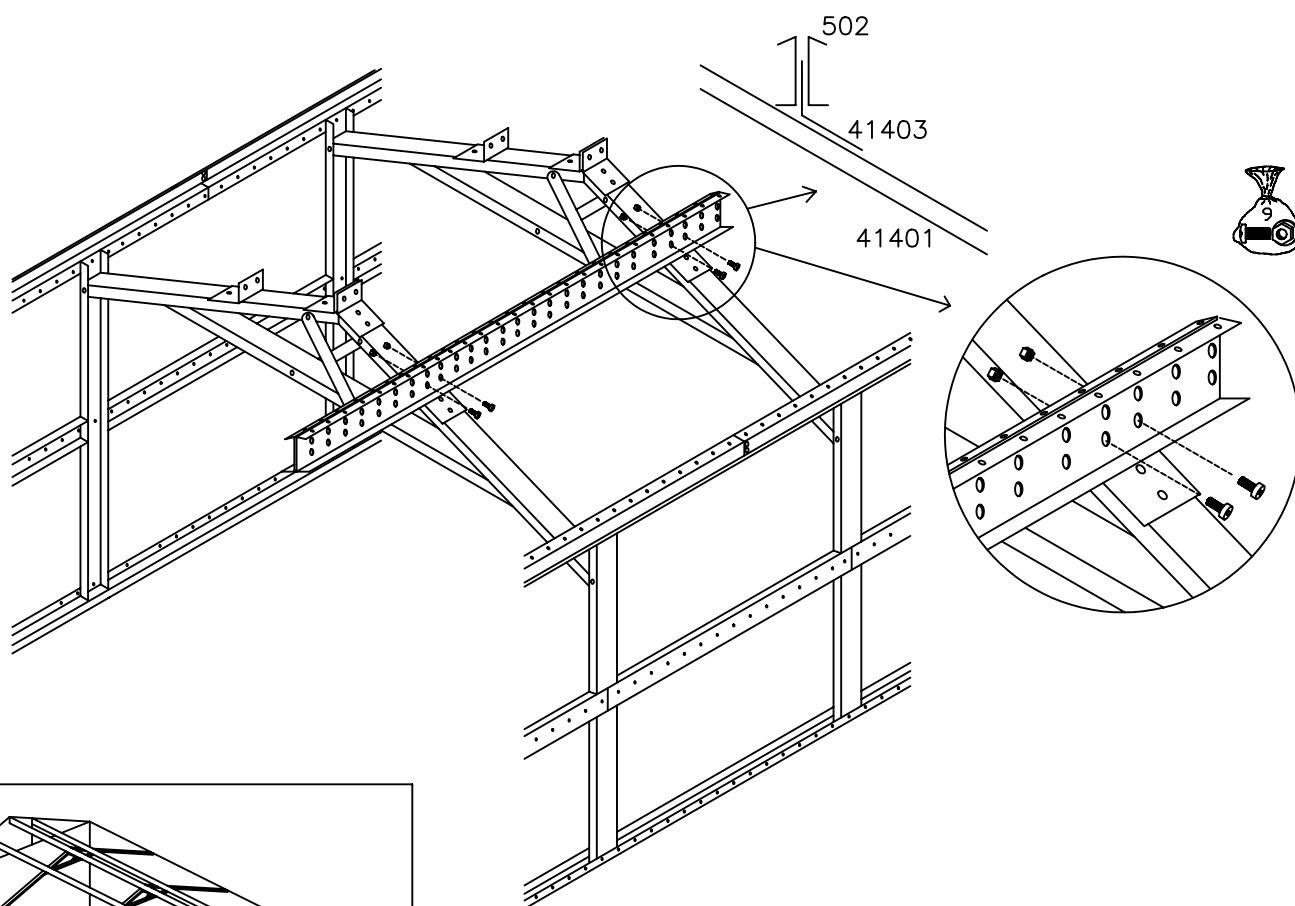

FIG. 5



## STEP 13 ROOF ASSEMBLY / ASSEMBLAGE DU TOIT

### ROOF ASSEMBLY

#### **MOST IMPORTANT!**

**BEFORE FITTING THE ROOF PANELS CHECK YOUR BUILDING FOR SQUARENESS BY ENSURING THAT THE DIAGONALS ARE EQUAL.**

1. Starting at the rear of the building fit roof panels 203.29 and 204.29 over gable flanges (panel should overlap gable by 75mm) and fix with screws (bag 1) and washers (bag 14) to gables, roof beams and sidebeams on each side of the building.
2. Fix ridge cover panel 50307 to roof panels using 12mm screws (bag 2) and washers (bag 14) leaving end holes free to fit ridge cover cap 507.
3. Fit narrow roof panels, 202.3 followed by 205 translucent roof panels secure with screws (bag 1) and washers (bag 14).  
**WHERE RIDGE COVER PANELS OVERLAP, FIX USING SCREWS AND WASHERS (BAGS 1&14).**
4. When the previous four panels are fitted, fix ridge cover panel 50303 with screws and washers (bags 2&14).
5. Fit roof panels 201.3 followed by ridge cover 50302. Secure using screws and washers (bags 1, 2&14).

**REPEAT OPERATION 5 FOR 5 MORE PANELS AND RIDGE COVERS EACH SIDE.**

6. Fix roof panels 203.29 and 204.29 at front of garage to gable, roof beams and side beams using screws (bag 1) and washers (bag 14).
7. Fix ridge cover panel, 50308 to front of garage (leave front holes free to ensure that ridge cover cap 507 can be fitted).

### ASSEMBLAGE DU TOIT

#### **TRES IMPORTANT**

**AVANT D'ASSEMBLER LES PANNEAUX DU TOIT, VOUS ASSURER QUE LE GARAGE EST A L'EQUERRE EN CONTROLANT QUE LES PROFILS DIAGONAUX SOIENT DE LONGUEUR EGALE.**

1. COMMENCER PAR L'ARRIERE DU GARAGE EN FIXANT LES PANNEAUX DE TOIT 203.29 AU DESSUS DES REBORDS DE PIGNON, ET FIXER A L'AIDE DES VIS DE LA POCHETTE NO.1 ET DES RONDELLES DE LA POCHETTE NO. 14 LES PIGNONS, POUTRES FAITIERES ET POUTRES DE COTE, SUR CHAQUE COTE DU GARAGE.
2. FIXER LE COUVRE FAITIERE 50307 SUR LES PANNEAUX DE TOIT EN UTILISANT LES VIS DE 12MM DE LA POCHETTE NO. 2 ET LES RONDELLES DE LA POCHETTE NO. 14, EN LAISSANT LE DERNIER LIBRE PERMETTANT DE FIXER LES EMBOUTS DE FAITIERE 507.
3. FIXER LE PETIT PANNEAU DE TOIT 202.3 AVEC LES VIS DE LA POCHETTE NO. 1 ET LES RONDELLES DE LA POCHETTE NO.14, PUIS LES PANNEAUX TRANSLUCIDES. UTILISER LA VISSERIE DE LA POCHETTE NO.1 POUR FIXER LES PANNEAUX SUPERPOSES.
4. LES 4 PANNEAUX PREVUS ETANT ASSEMBLES, FIXER LA COUVRE FAITIERE 50303 AVEC LA VISSERIE DE LA POCHETTE NO.2 ET LES RONDELLES DE LA POCHETTE NO.14.
5. FIXER LES PANNEAUX DE TOIT 201.3 PUIS LE COUVRE FAITIERE 50302, AVEC LES VIS DE LA POCHETTE NO. 1 ET LES RONDELLES DE LA POCHETTE NO. 14.

REPETER OPERATION 5 PANNEAUX ADDITIONELS ET COURESFAITIERES.

6. FIXER LES PANNEAUX DE TOIT 203.29 ET 204.29 AUX PIGNONS AVANT DU GARAGE, POUTRE DE TOIT ET DE COTE, EN UTILISANT LA VISSERIE DE LA POCHETTE NO.14 ET LES RONDELLES DE LA POCHETTE NO.14.
7. FIXER LA COUVRE FAITIERE 50308 A L'AVANT DU GARGAGE, EN LAISSANT LES TROUS LIBRES POUR FIXER L'EMBOUT DE FAITIERE.



STEP 13 ROOF ASSEMBLY / ASSEMBLAGE DU TOIT

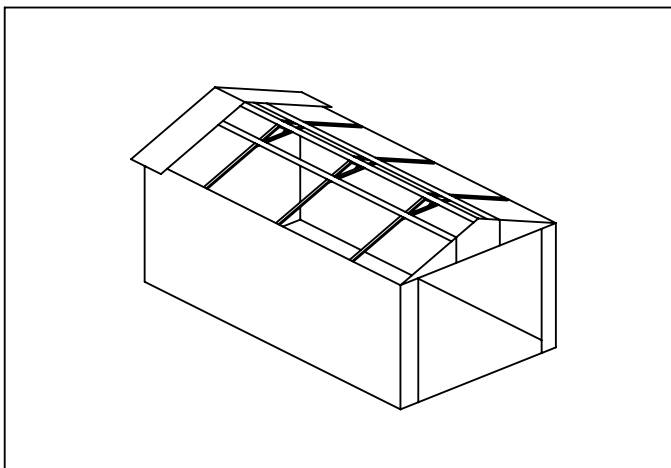
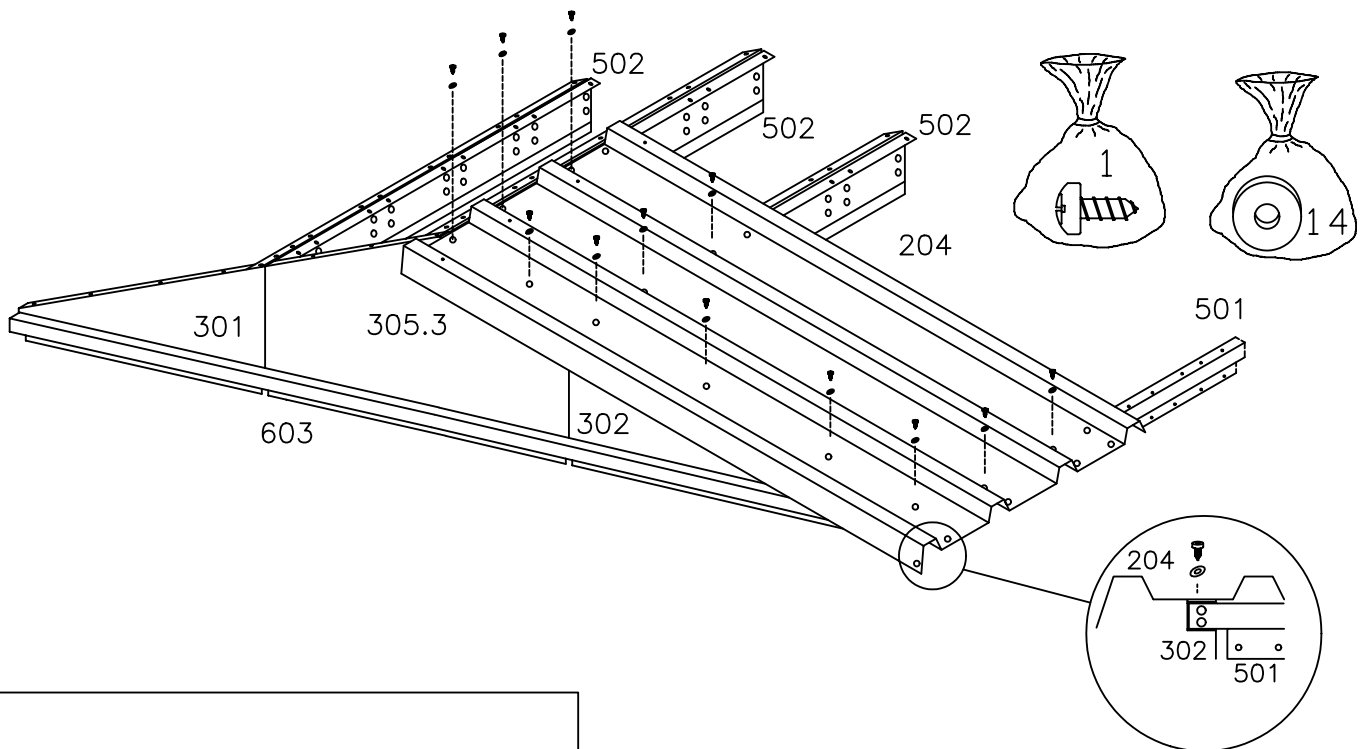
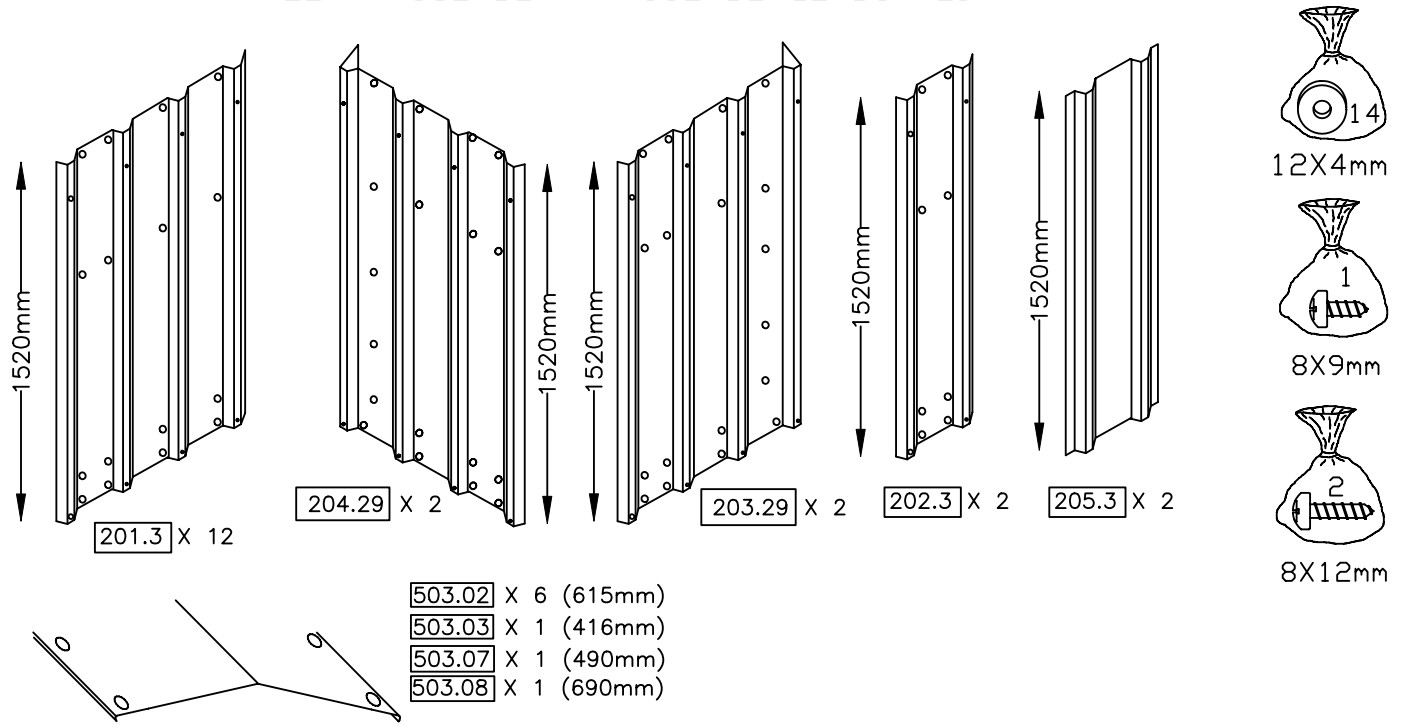

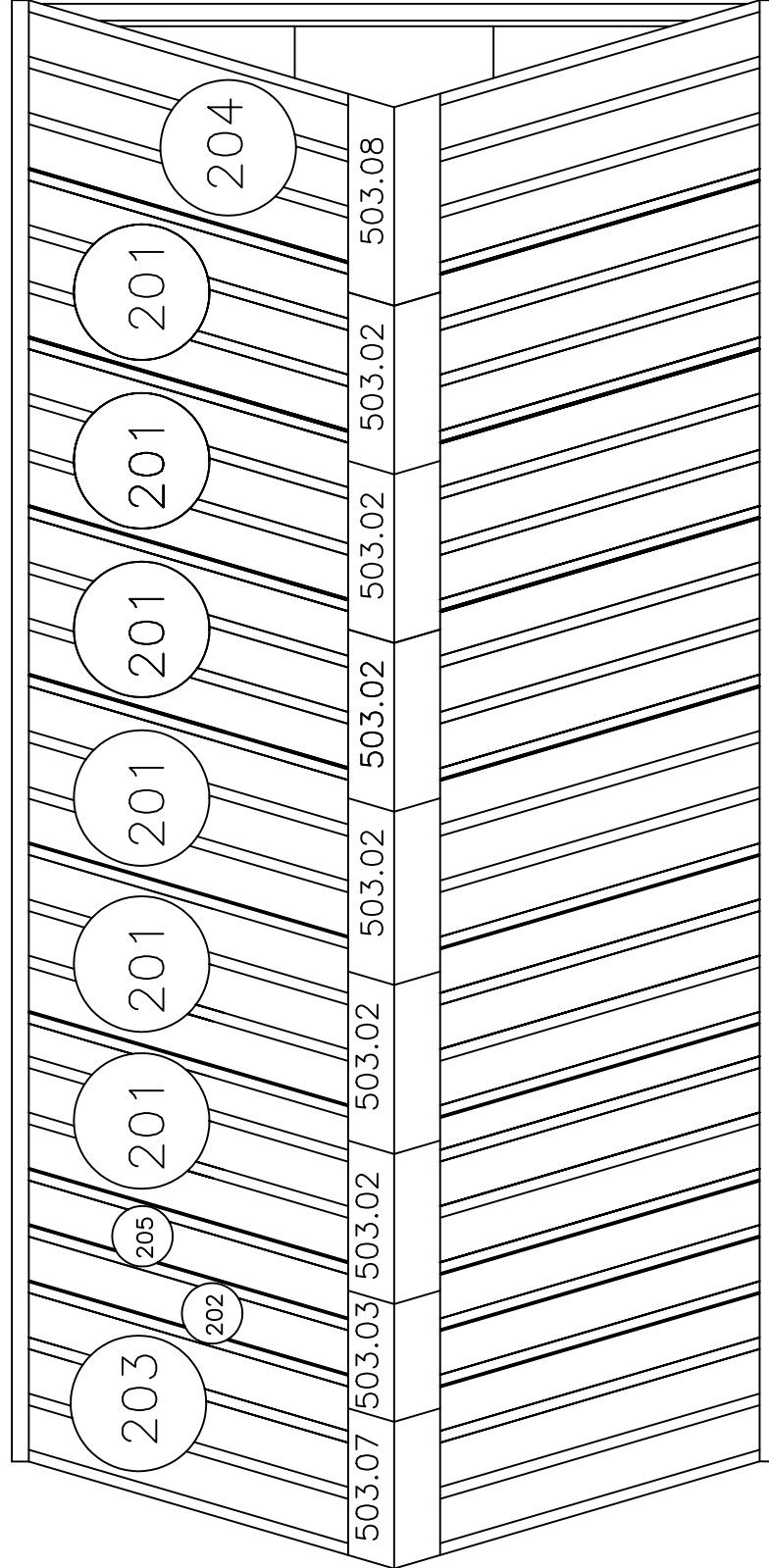
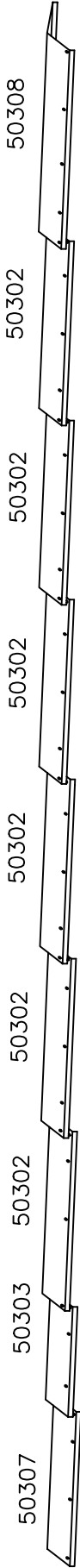
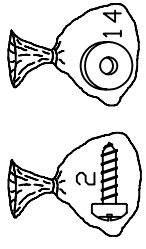

FRONT  
DEVANT

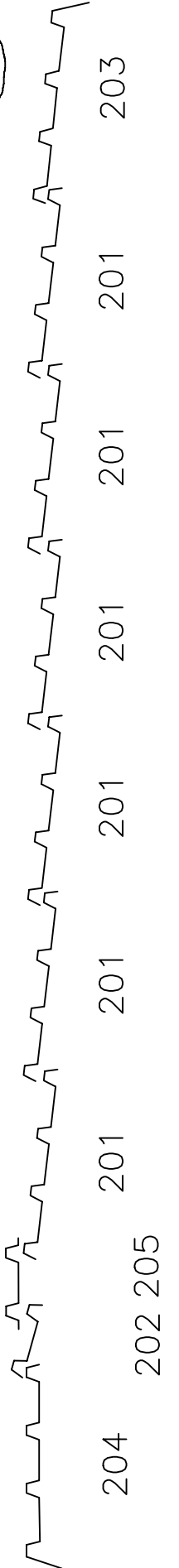
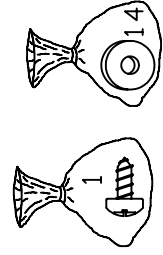

## STEP 14

RIDGE CAP, GUTTER ANGLE AND GUTTER END CAP FITTING  
FIXATION DES EMBOUTS DE FAITIERE, MONTAGE DES GOUTTIERES  
EMBOUITS DE GOUTTIERE

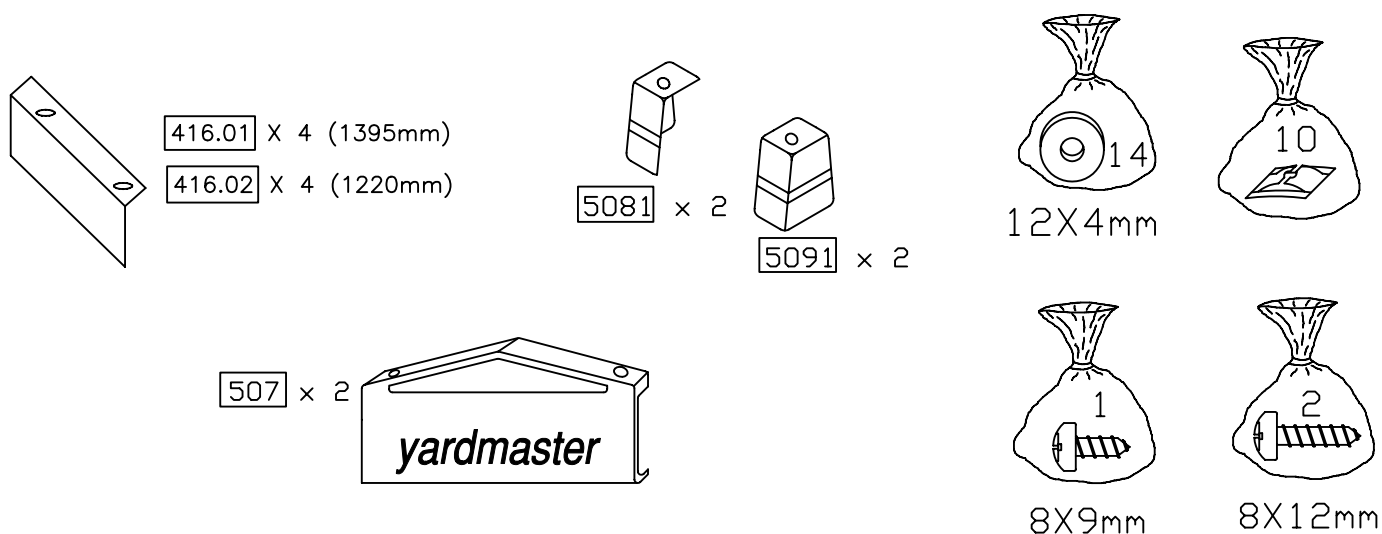

### RIDGE CAP COVER FITTING.GUTTER ANGLE FITTING.GUTTER END CAP FITTING.

1. Fit ridge cover caps 507 over the end of the ridge cover ensuring that the bottom edge of 507 is under the overhang of the roof panels.
2. Fasten through the ridge cover into the roof panels using screws (bag 2), washers (bag 14) and spire clips (bag 10).
3. Fit gutter angles starting from front right with 41601 angle to ribs at bottom of roof panels with screws (bag 1) and washers (bag 14). Continue with 2 x 41602 angles and finally a 41601 angle at the rear.
4. Fit gutter end caps 508.1 and 509.1 to each corner of garage at point where gutter angle end and corner roof panel meet.

### FIXATION DES EMBOUTS DE FAITIERE, MONTAGE DES GOUTTIERES, EMBOUTS DE GOUTTIERE.

1. ASSEMBLER LES EMBOUTS DE FAITIERES 507 A L'EXTREMITÉ DU COUVRE FAITIERE, EN VOUS ASSURANT QUE LE REBORD DES EMDOUTS DE FAITIERES 507 SOIT FIXE EN DESSOUS DES PANNEAUX DE TOIT.
2. FIXER LES EMDOUTS DE FAITIERES SUR LES PANNEAUX DE TOIT A L'AIDE DE LA VISSERIE DE LA POCHETTE NO.2, DES RONDELLES DE LA POCHETTE NO. 14 ET DE VISSERIE DE LA POCHETTE NO.10.
3. ASSEMBLER LES ANGLES DE EN COMMENCANT PAR L'ANGLE DE GOUTTIERE DE DROITE 41601. LA FIXER AUX PANNEAUX DE TOIT AVEC LES VIS DE LA POCHETTE NO. 1 ET 14 SANS OUBLIER, CONTINUER AVEC 2 ANGLES 416.02 ET FINALEMENT UN ANGLE 41601 A L'ARRIERE.
4. FIXER LES EMBOUTS PLASTIQUE DE GOUTTIERES 508.1 ET 509.1 A CHAQUE DE TOIT DU GARAGE, A LA RENCONTRE DES EXTREMITES DES GOUTTIERES ET DES ANGLES DES PANNEAUX DE TOIT.

STEP 14

RIDGE CAP, GUTTER ANGLE AND GUTTER END CAP FITTING  
 FIXATION DES EMBOUTS DE FAITIERE, MONTAGE DES GOUTTIERES  
 EMBOUTS DE GOUTTIERE

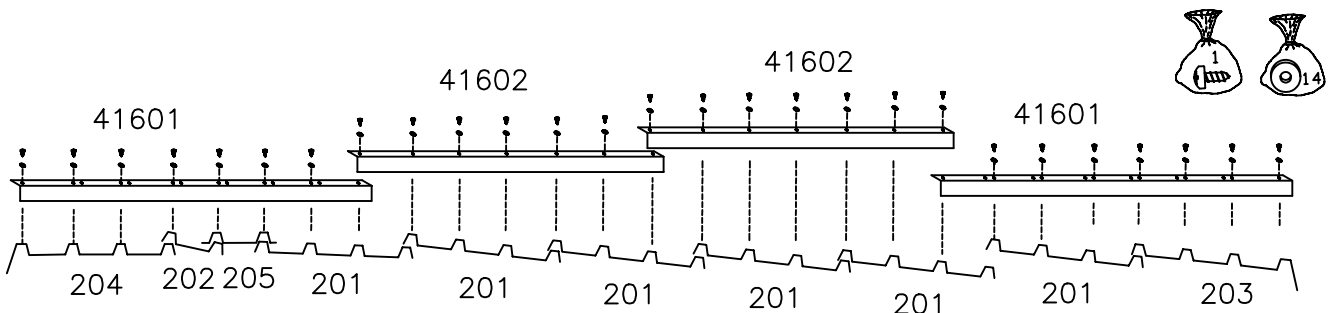
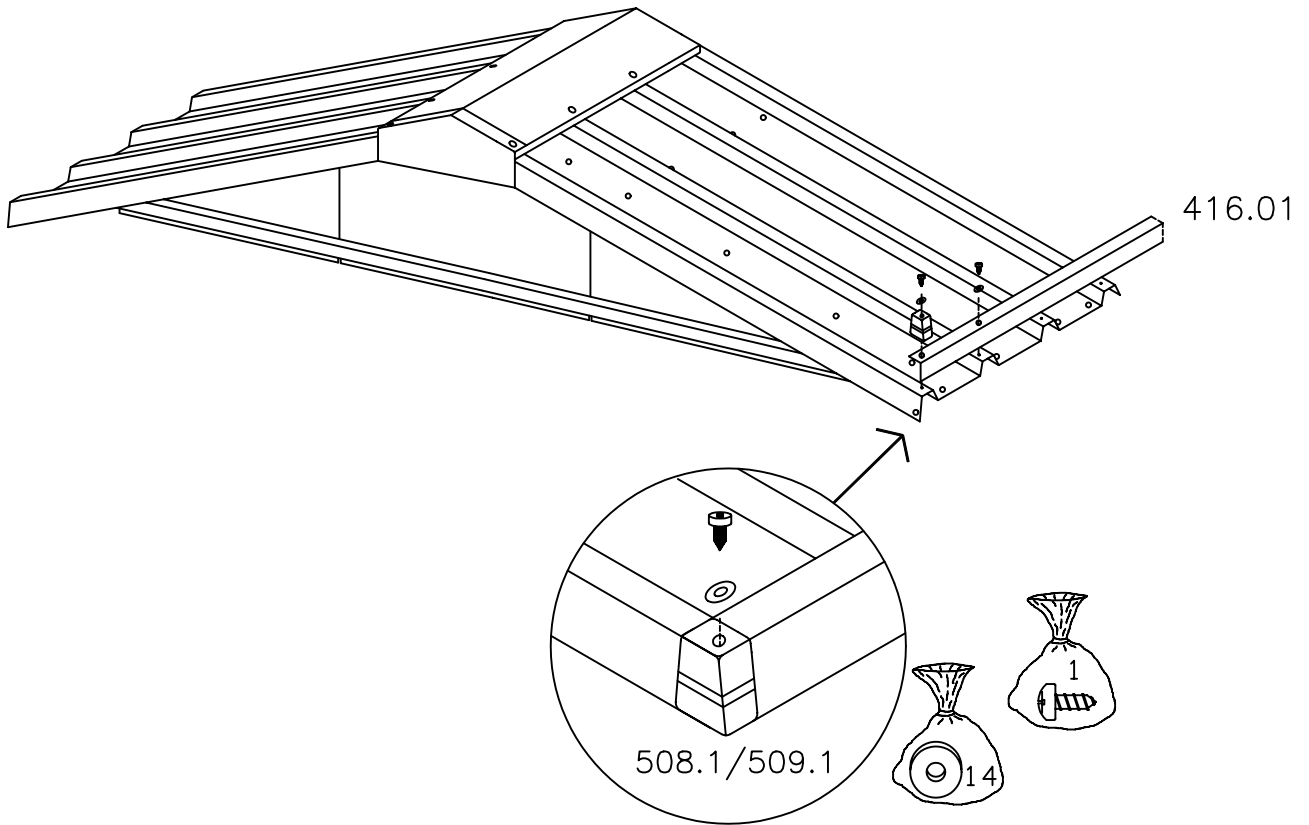
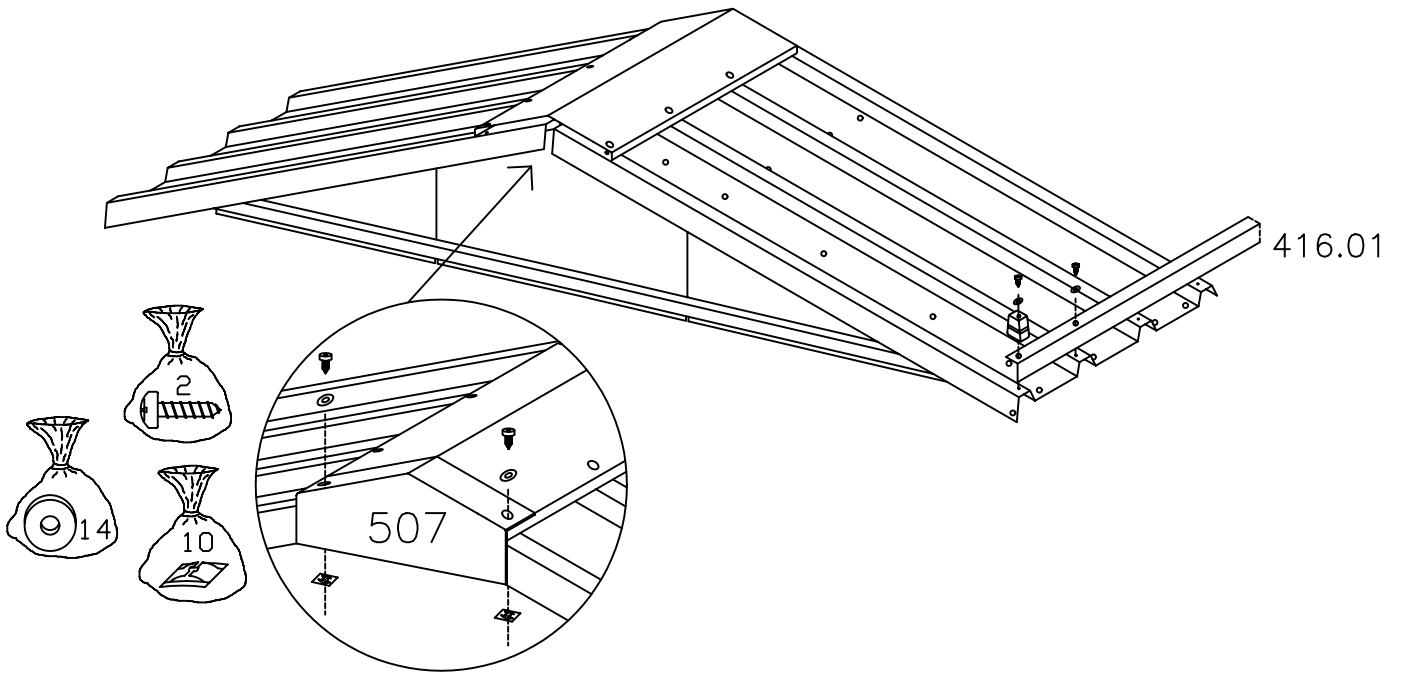

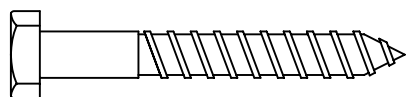

M8X50mm X 13

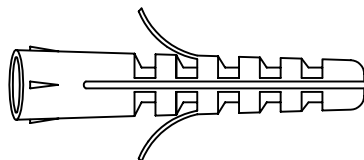

M10X50mm X 13

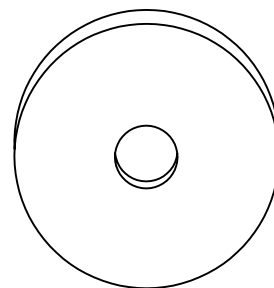

X 13

### **ANCHORING GARAGE.**

1. Anchor garage in the 13 positions shown with anchor kit provided (M8 x 50 coach screws plugs and washers). Holes to locate are punched in the base rails.  
Positions: 2 in front frame, 4 along each side, 3 along rear

**POSITION OF GARAGE MUST BE DETERMINED AT THIS POINT AND SQUARENESS MUST BE ENSURED.**

2. When anchoring is complete, hang doors in position using the remainder of the countersunk bolts, nuts and washers provided.

### **ANCRAGE DE L'ABRI**

1. FIXER L'ABRI DANS LE 13 POSITIONS MONTRES AVEC LE KIT D'ANCRAGE PREVU. M8 X 50 VIS DE CARROSSIER, CHEVILLES ET RONDELLES. TROUS A LOCALISES SONT PERCES DANS LES RAILS BASES.  
POSITIONS: 2 DANS LA STRUCTURE AVANTE, 4 SUR CHAQUE COTE, 3 SUR L'ARRIERE.

**IL FAUT DETERMINER LA POSITION DE LA GARAGE A CE MOMENT ET S'ASSURER DE LA RECTITUDE.**

2. APRES AVOIR FINI L'ANCRAGE, MONTER LES PORTES AVEC LE RESTE DES BOULONS NOYES, ECROUS ET RONDELLES PREVUS.

STEP 15

ANCHORING THE GARAGE / ANCRAGE DE L'ABRI

