**Robert Bosch GmbH**

Power Tools Division  
70764 Leinfelden-Echterdingen  
GERMANY

[www.bosch-pt.com](http://www.bosch-pt.com)

**1 609 92A 15R** (2015.01) PS / 386 EURO



1 609 92A 15R

## GTS 10 J Professional



**BOSCH**

<b>de</b> Originalbetriebsanleitung	<b>pl</b> Instrukcja oryginalna	<b>sr</b> Originalno uputstvo za rad
<b>en</b> Original instructions	<b>cs</b> Původní návod k používání	<b>sl</b> Izvirna navodila
<b>fr</b> Notice originale	<b>sk</b> Pôvodný návod na použitie	<b>hr</b> Originalne upute za rad
<b>es</b> Manual original	<b>hu</b> Eredeti használati utasítás	<b>et</b> Algupärane kasutusjuhend
<b>pt</b> Manual original	<b>ru</b> Оригинальное руководство по эксплуатации	<b>lv</b> Instrukcijas oriģinālvalodā
<b>it</b> Istruzioni originali	<b>uk</b> Оригінальна інструкція з експлуатації	<b>lt</b> Originali instrukcija
<b>nl</b> Oorspronkelijke gebruiksaanwijzing	<b>kk</b> Пайдалану нұсқаулығының түпнұсқасы	<b>ar</b> تعليمات التشغيل الأصلية
<b>da</b> Original brugsanvisning	<b>ro</b> Instrucțiuni originale	<b>fa</b> دفترچه راهنمای اصلی
<b>sv</b> Bruksanvisning i original	<b>bg</b> Оригинална инструкция	
<b>no</b> Original driftsinstruks	<b>mk</b> Originalno upatstvo za работа	
<b>fi</b> Alkuperäiset ohjeet		
<b>el</b> Πρωτότυπο οδηγιών χρήσης		
<b>tr</b> Orijinal işletme talimatı		

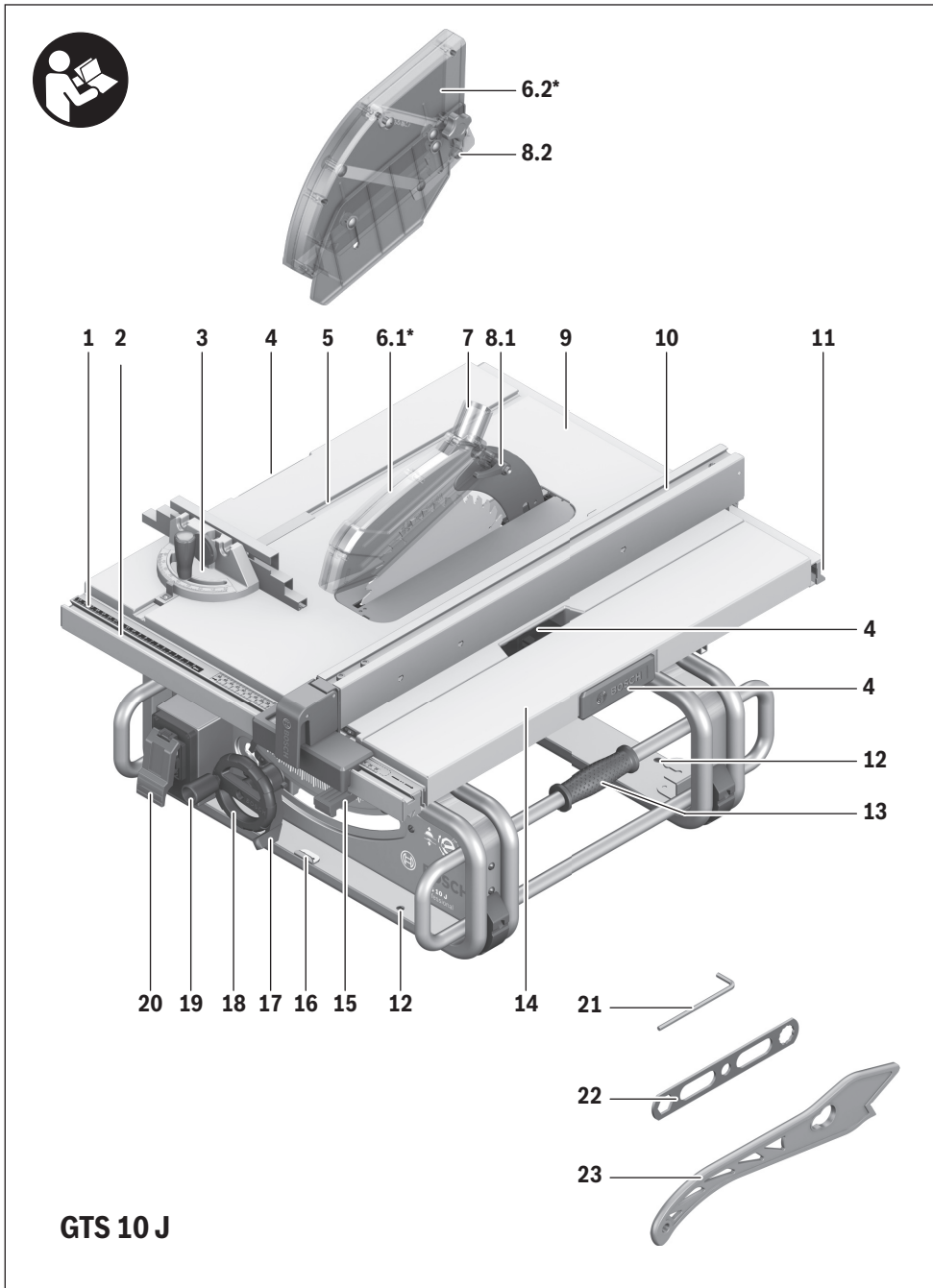

Deutsch .....	Seite	15
English .....	Page	27
Français .....	Page	39
Español .....	Página	51
Português.....	Página	64
Italiano .....	Pagina	76
Nederlands .....	Pagina	89
Dansk .....	Side	101
Svenska .....	Sida	112
Norsk .....	Side	123
Suomi .....	Sivu	134
Ελληνικά .....	Σελίδα	145
Türkçe .....	Sayfa	158
Polski .....	Strona	170
Česky .....	Strana	182
Slovensky.....	Strana	193
Magyar .....	Oldal	205
Русский .....	Страница	217
Українська.....	Сторінка	230
Қазақша.....	Бет	243
Română .....	Pagina	255
Български .....	Страница	267
Македонски .....	Страна	280
Srpski .....	Strana	293
Slovensko .....	Stran	304
Hrvatski .....	Stranica	315
Eesti .....	Lehekülj	326
Latviešu .....	Lappuse	337
Lietuviškai .....	Puslapis	349
عربي .....	صفحة	372
فارسی .....	صفحه	385

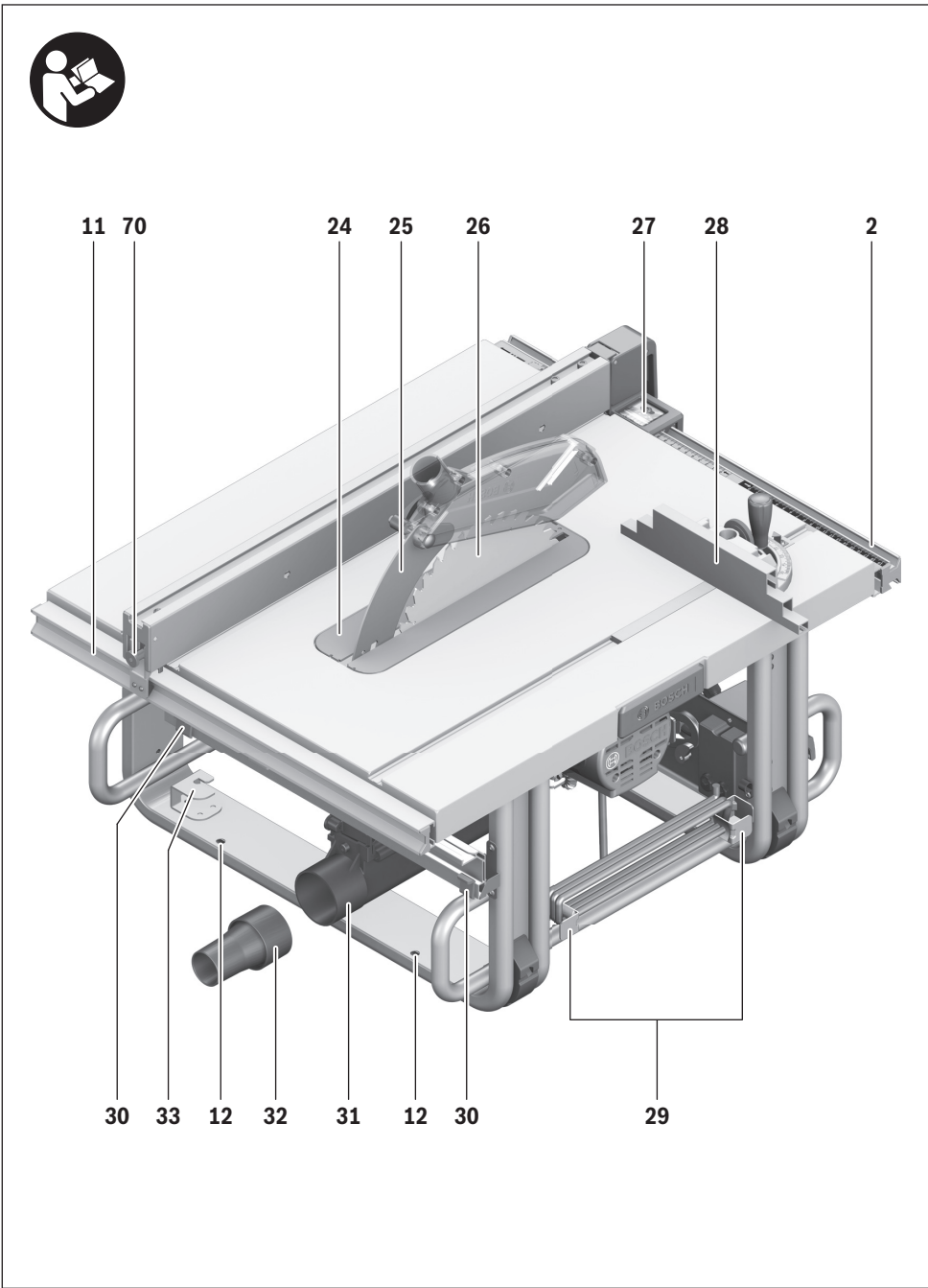





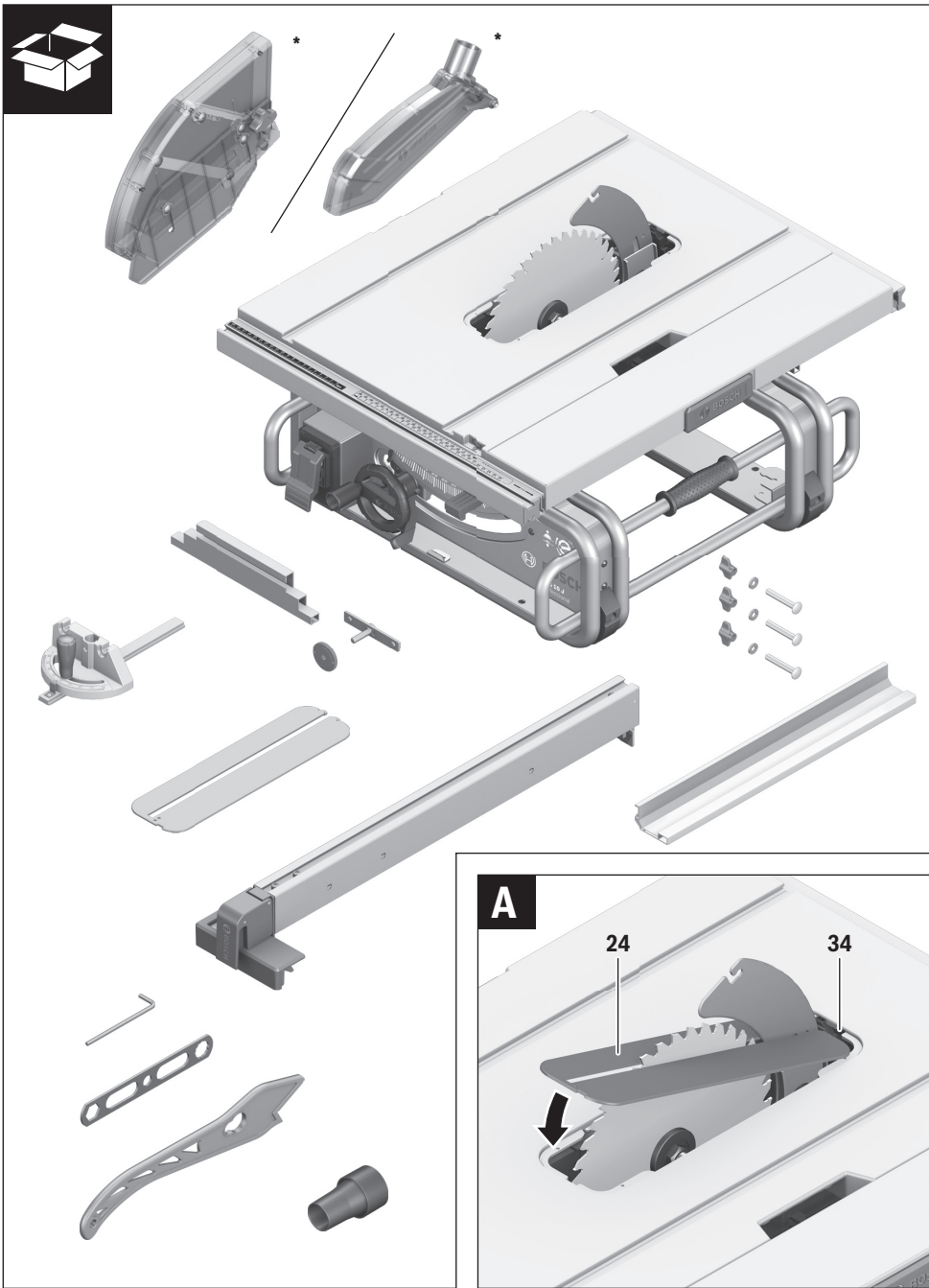

6 |

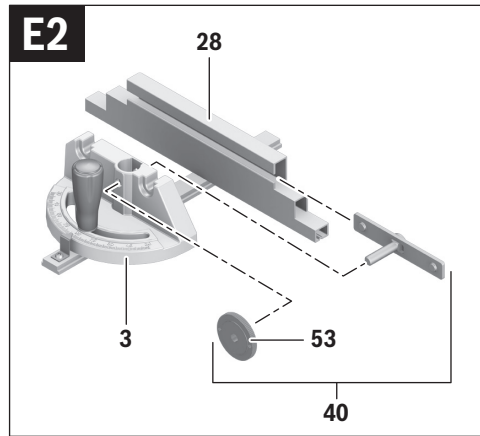
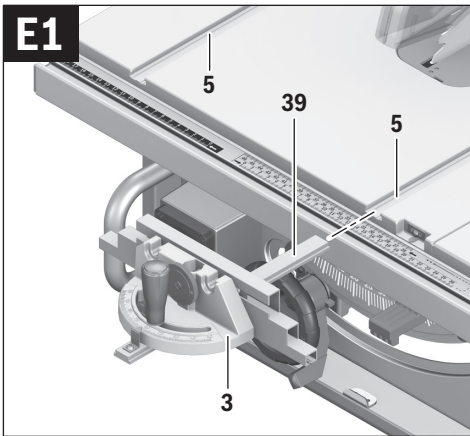
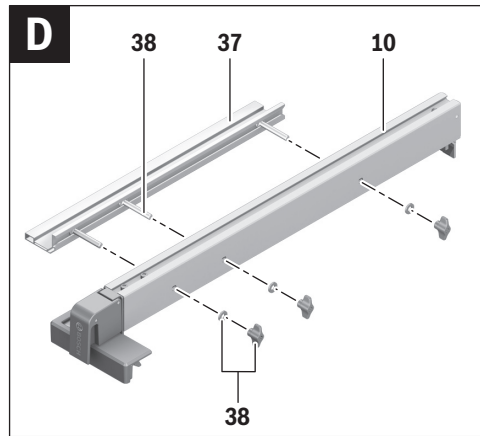
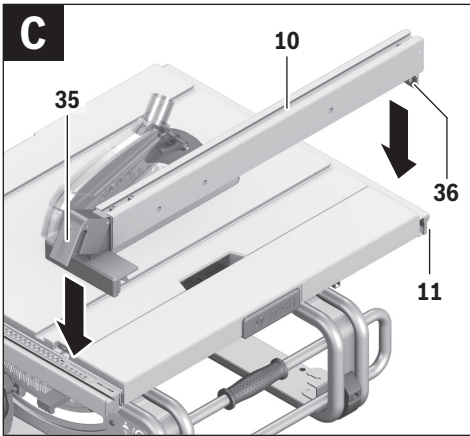
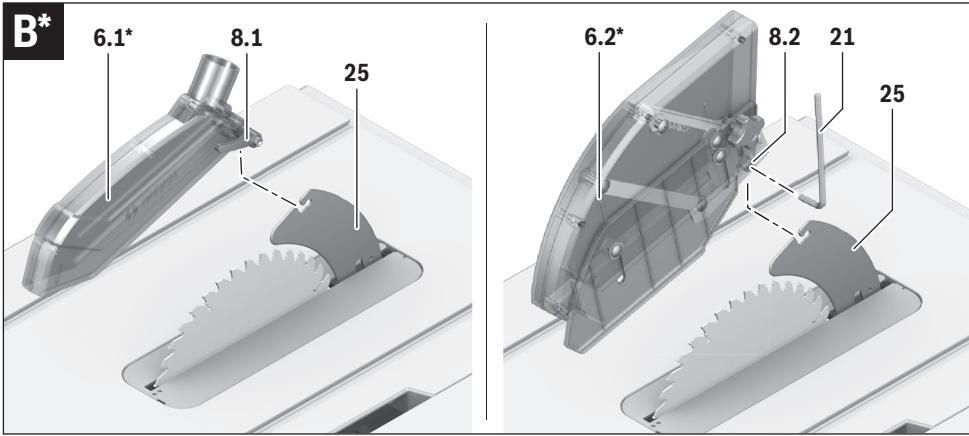

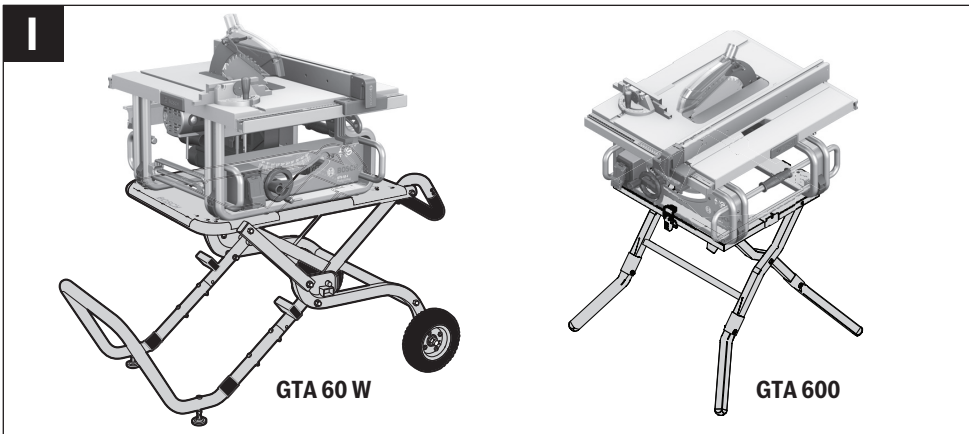
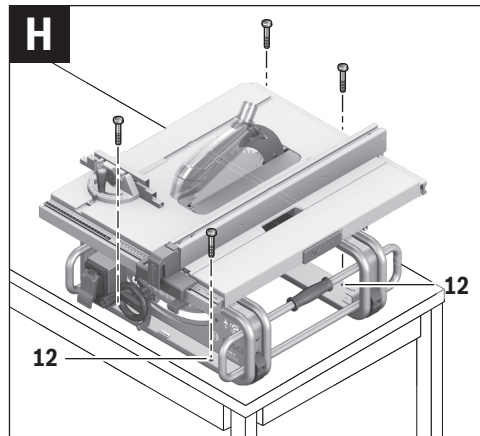
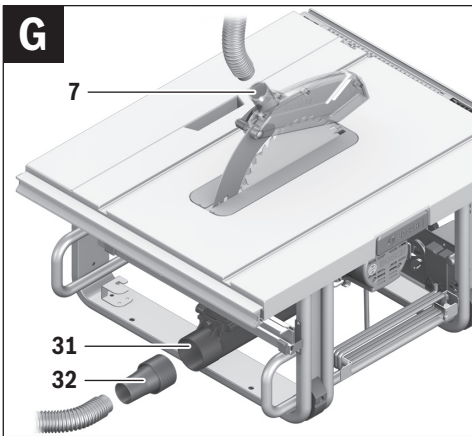
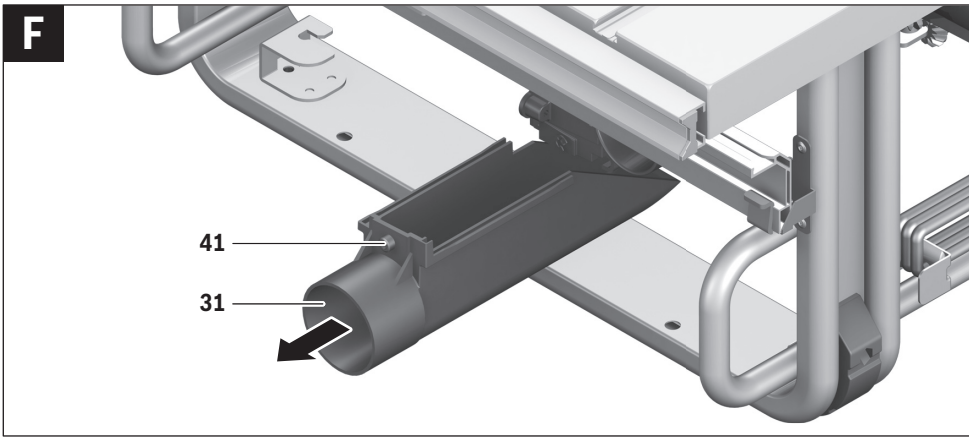

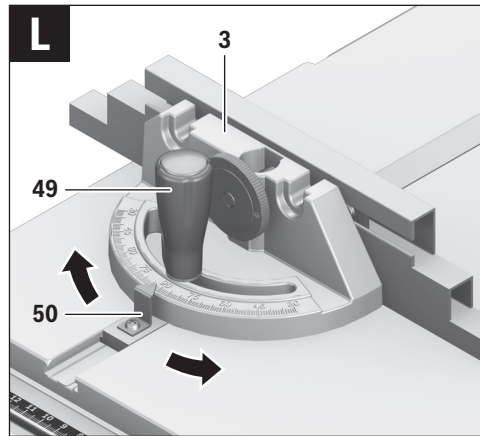
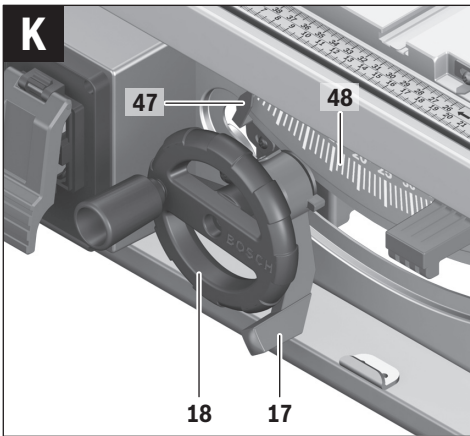
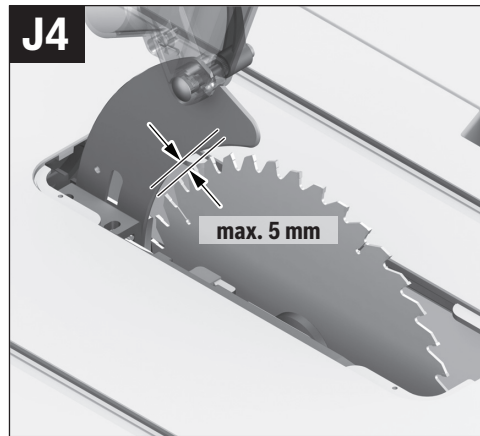
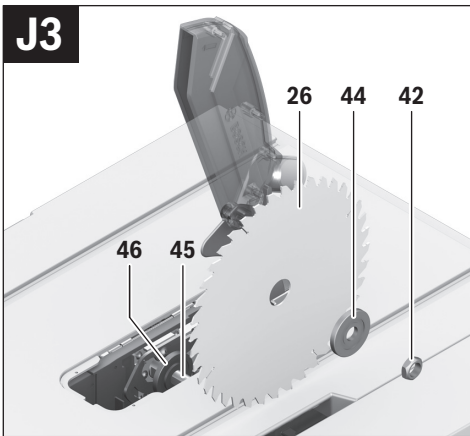
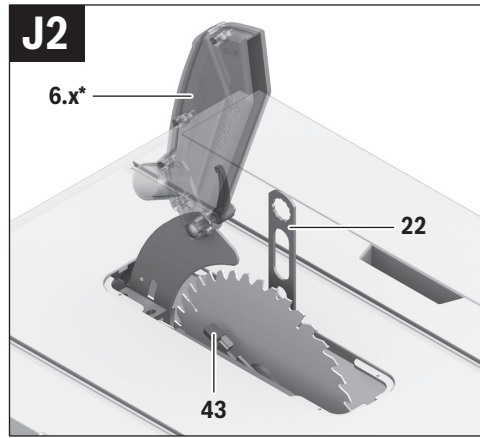
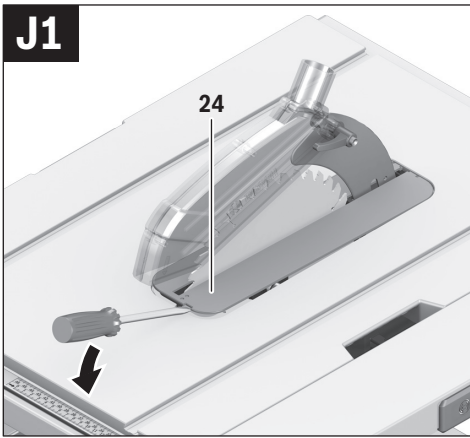

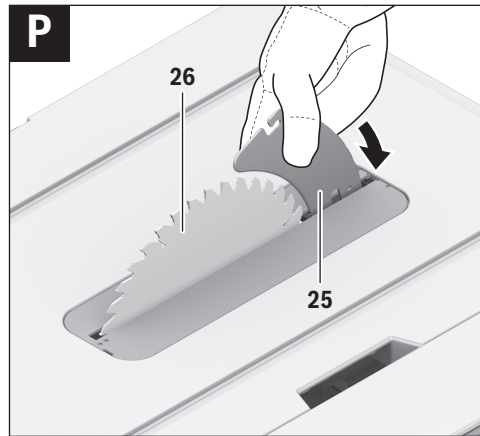
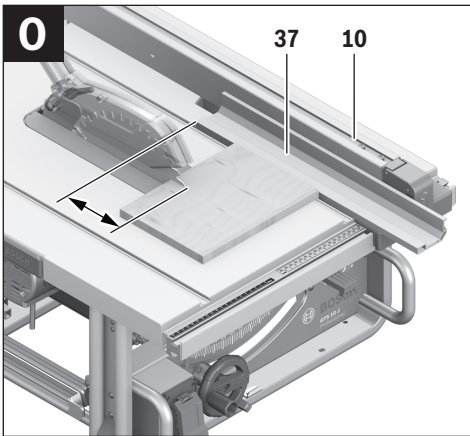
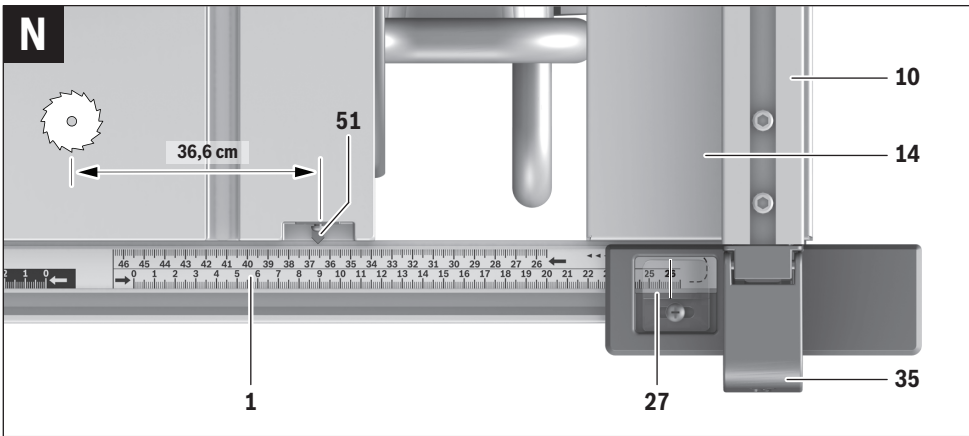
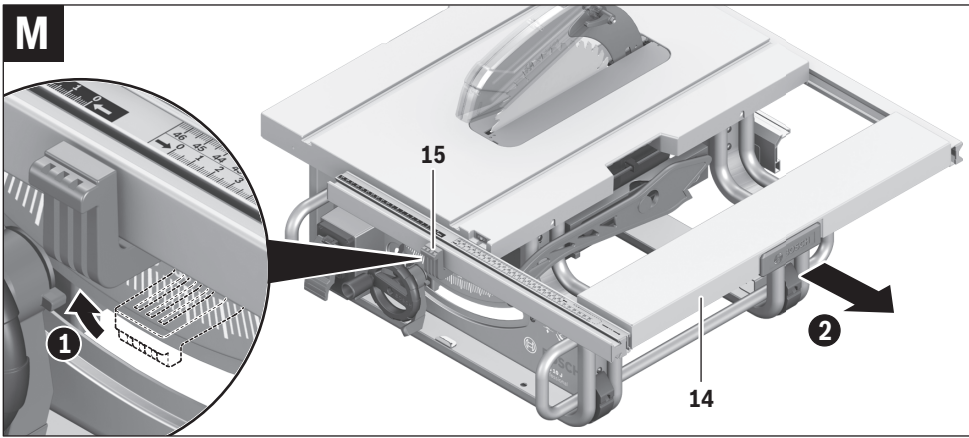



10 |

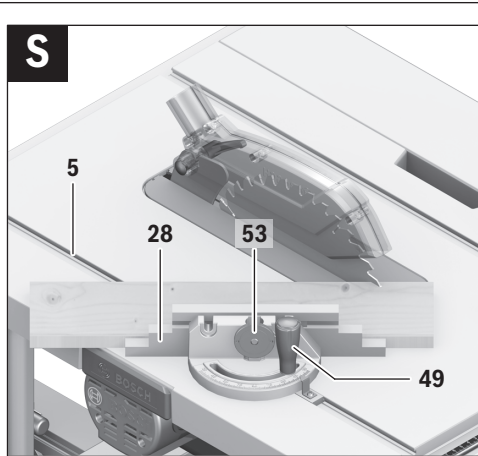
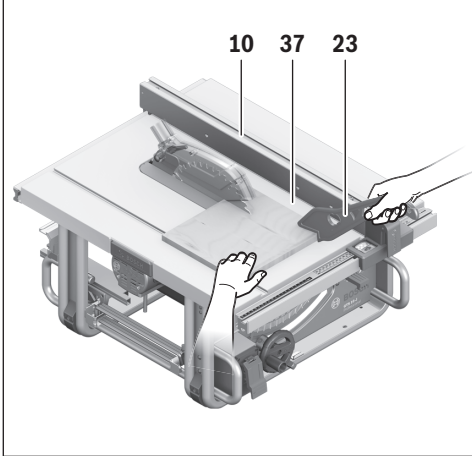
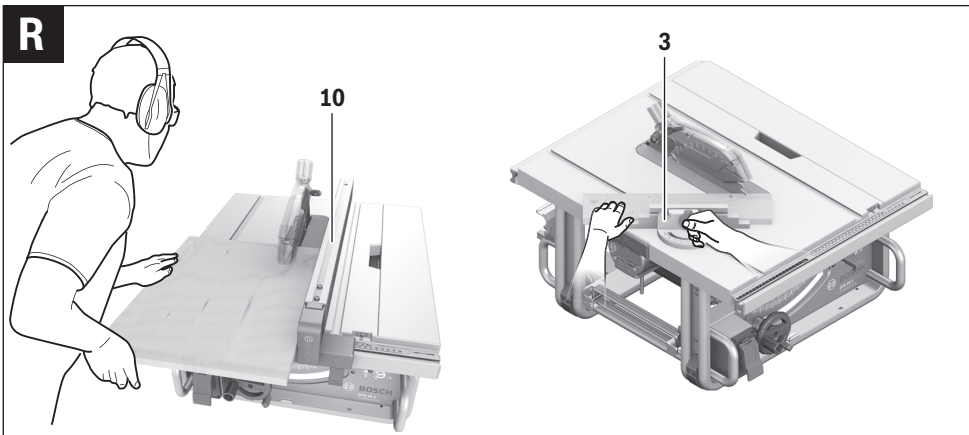
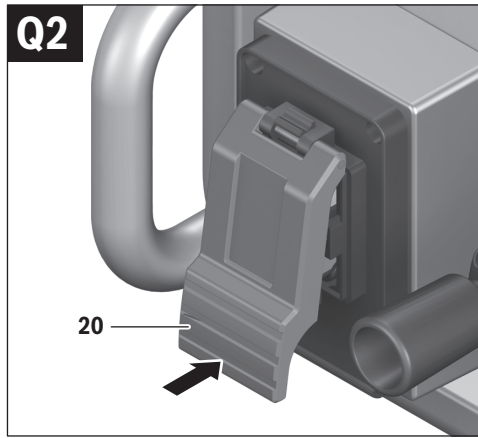
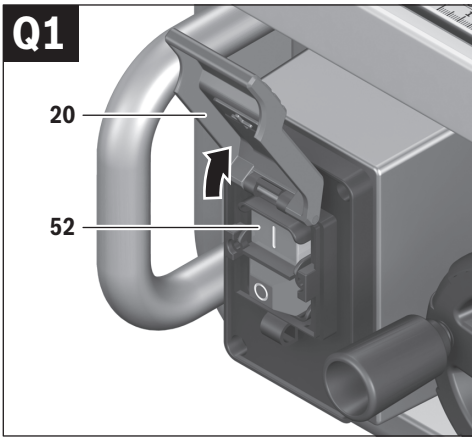

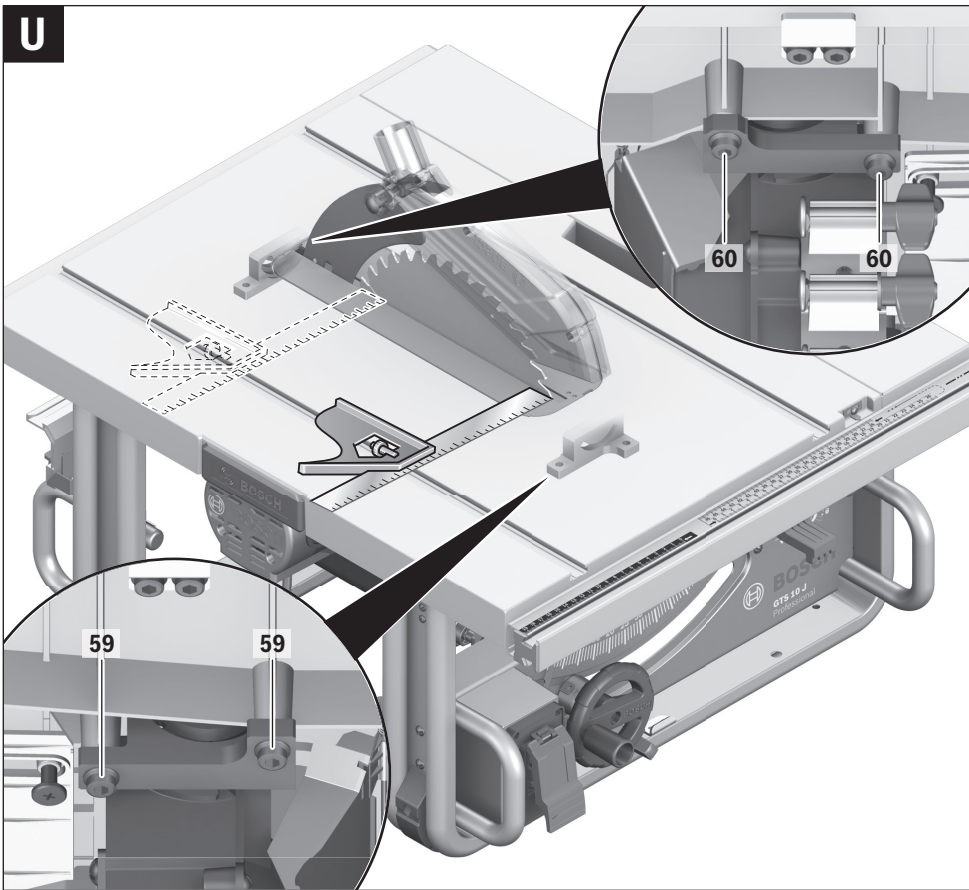
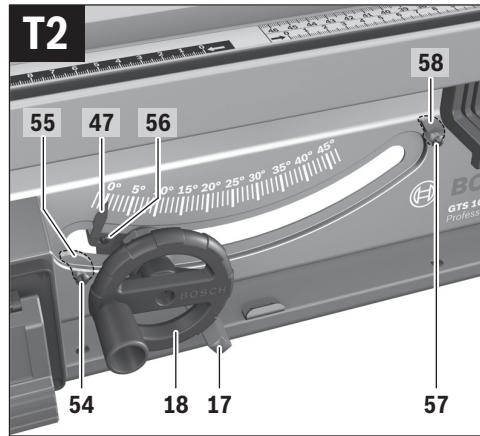
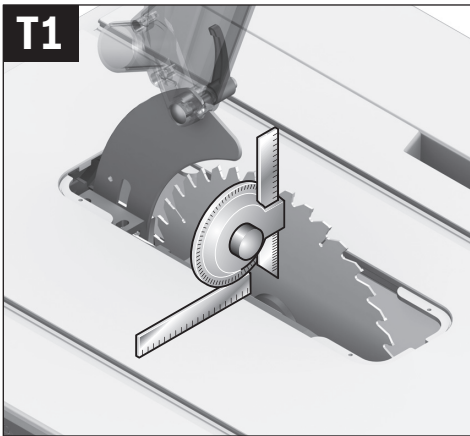

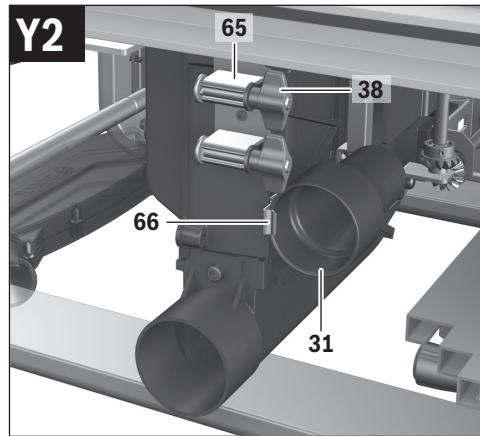
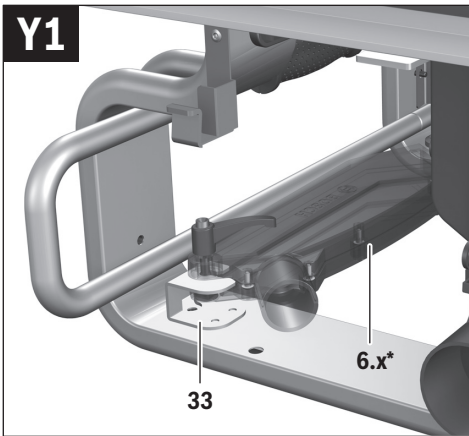
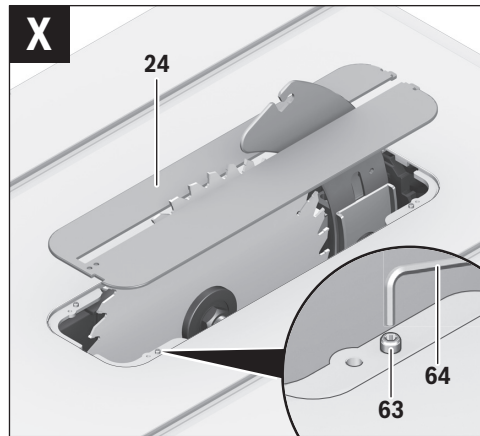
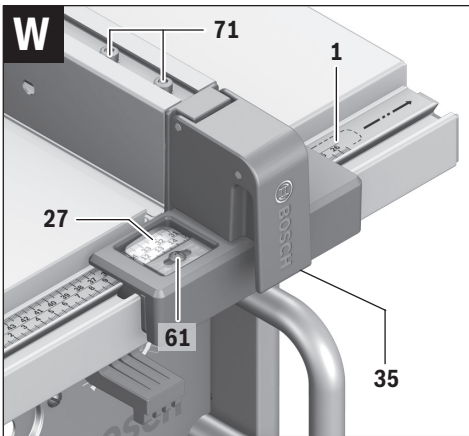
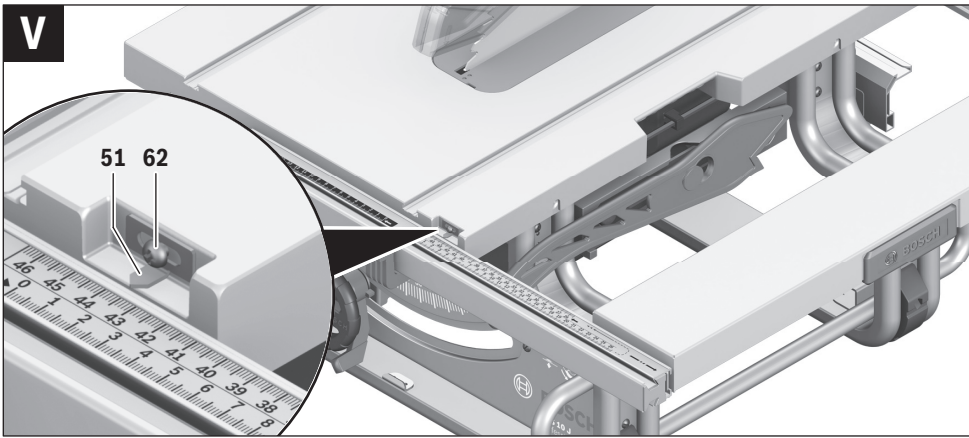



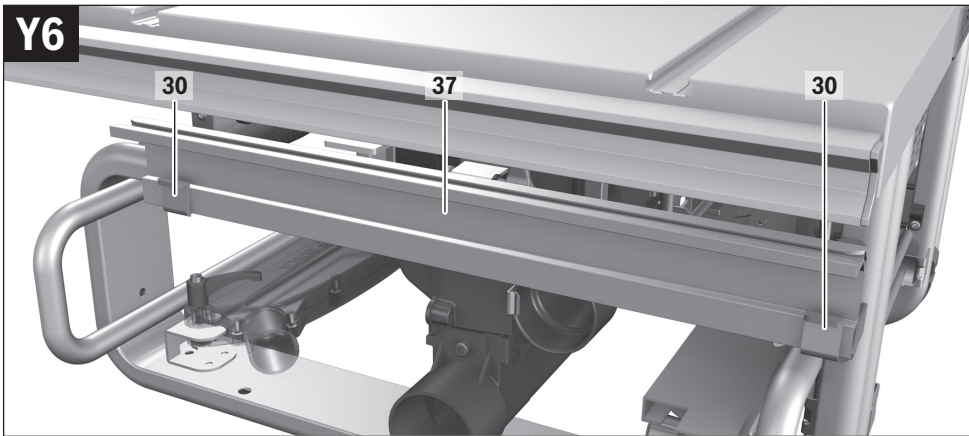
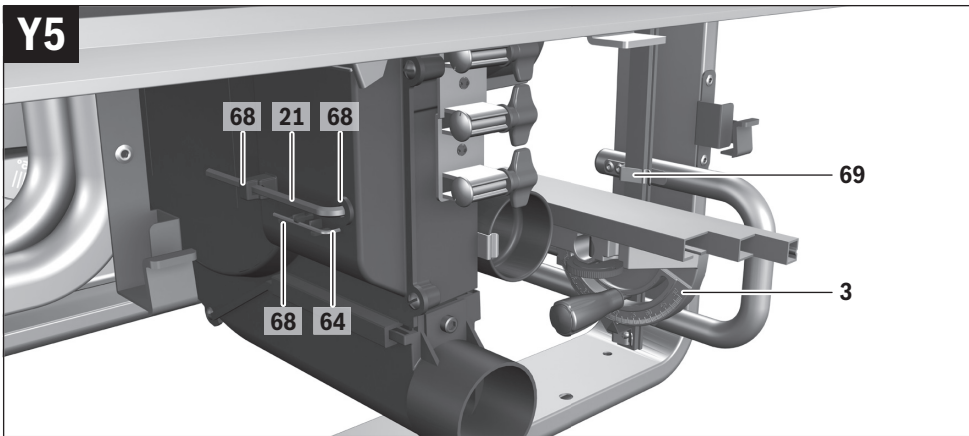
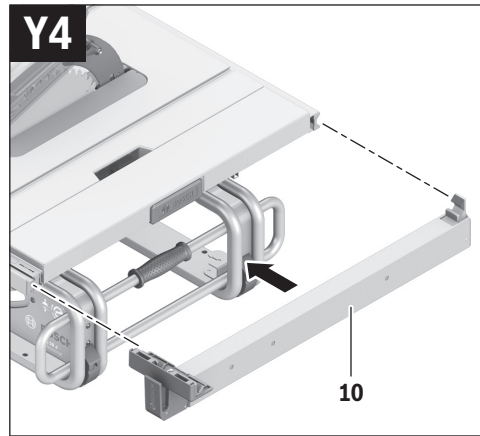
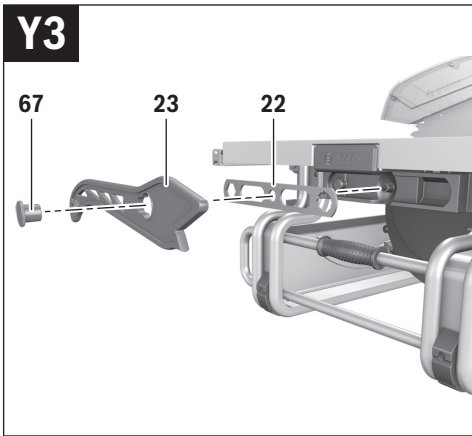

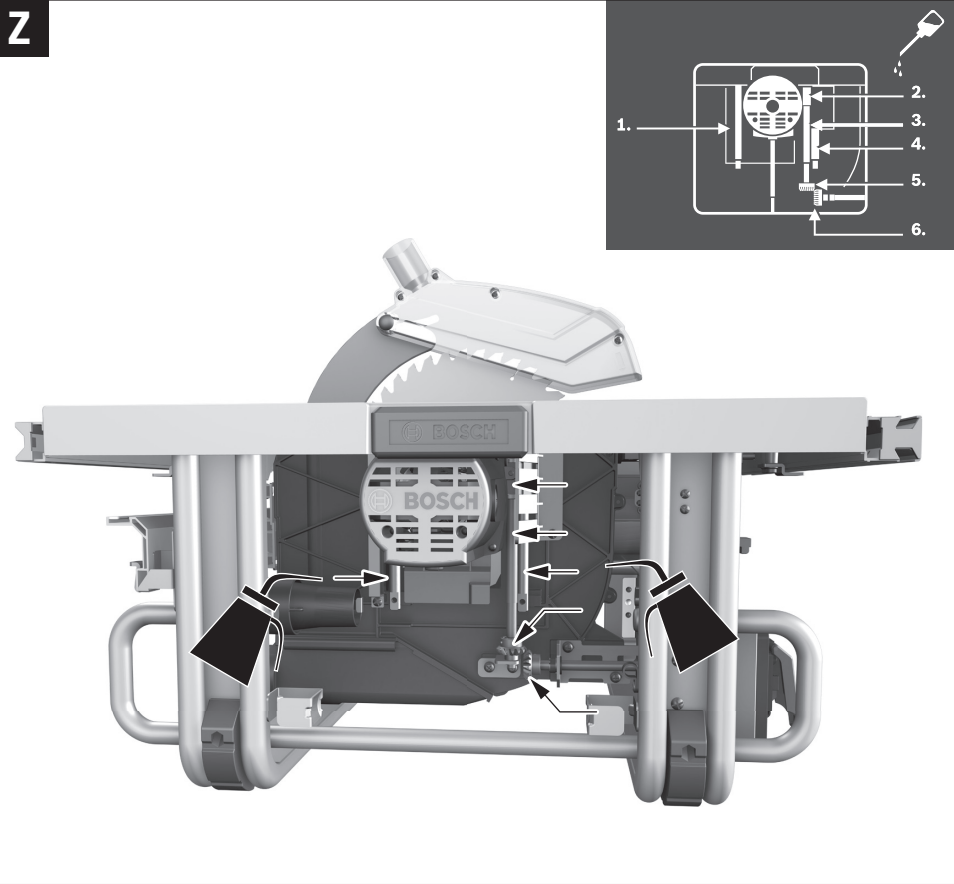

## English

### Safety Notes

#### General Power Tool Safety Warnings

**⚠ IMPORTANT** When using electric tools basic safety precautions should always be followed to reduce the risk of fire, electric shock and personal injury including the following.

**Read all these instructions before attempting to operate this product and save these instructions.**

The term "power tool" in the warnings refers to your mains-operated (corded) power tool or battery-operated (cordless) power tool.

#### Work area safety

- ▶ **Keep work area clean and well lit.** Cluttered or dark areas invite accidents.
- ▶ **Do not operate power tools in explosive atmospheres, such as in the presence of flammable liquids, gases or dust.** Power tools create sparks which may ignite the dust or fumes.
- ▶ **Keep children and bystanders away while operating a power tool.** Distractions can cause you to lose control.

#### Electrical safety

- ▶ **Power tool plugs must match the outlet. Never modify the plug in any way. Do not use any adapter plugs with earthed (grounded) power tools.** Unmodified plugs and matching outlets will reduce risk of electric shock.
- ▶ **Avoid body contact with earthed or grounded surfaces, such as pipes, radiators, ranges and refrigerators.** There is an increased risk of electric shock if your body is earthed or grounded.
- ▶ **Do not expose power tools to rain or wet conditions.** Water entering a power tool will increase the risk of electric shock.
- ▶ **Do not abuse the cord. Never use the cord for carrying, pulling or unplugging the power tool. Keep cord away from heat, oil, sharp edges and moving parts.** Damaged or entangled cords increase the risk of electric shock.
- ▶ **When operating a power tool outdoors, use an extension cord suitable for outdoor use.** Use of a cord suitable for outdoor use reduces the risk of electric shock.
- ▶ **If operating a power tool in a damp location is unavoidable, use a residual current device (RCD) protected supply.** Use of an RCD reduces the risk of electric shock.

#### Personal safety

- ▶ **Stay alert, watch what you are doing and use common sense when operating a power tool. Do not use a power tool while you are tired or under the influence of drugs, alcohol or medication.** A moment of inattention while operating power tools may result in serious personal injury.
- ▶ **Use personal protective equipment. Always wear eye protection.** Protective equipment such as dust mask, non-skid safety shoes, hard hat, or hearing protection used for appropriate conditions will reduce personal injuries.

- ▶ **Prevent unintentional starting. Ensure the switch is in the off-position before connecting to power source and/or battery pack, picking up or carrying the tool.**

Carrying power tools with your finger on the switch or energising power tools that have the switch on invites accidents.

- ▶ **Remove any adjusting key or wrench before turning the power tool on.** A wrench or a key left attached to a rotating part of the power tool may result in personal injury.
- ▶ **Do not overreach. Keep proper footing and balance at all times.** This enables better control of the power tool in unexpected situations.
- ▶ **Dress properly. Do not wear loose clothing or jewellery. Keep your hair, clothing and gloves away from moving parts.** Loose clothes, jewellery or long hair can be caught in moving parts.
- ▶ **If devices are provided for the connection of dust extraction and collection facilities, ensure these are connected and properly used.** Use of dust collection can reduce dust-related hazards.

#### Power tool use and care

- ▶ **Do not force the power tool. Use the correct power tool for your application.** The correct power tool will do the job better and safer at the rate for which it was designed.
- ▶ **Do not use the power tool if the switch does not turn it on and off.** Any power tool that cannot be controlled with the switch is dangerous and must be repaired.
- ▶ **Disconnect the plug from the power source and/or the battery pack from the power tool before making any adjustments, changing accessories, or storing power tools.** Such preventive safety measures reduce the risk of starting the power tool accidentally.
- ▶ **Store idle power tools out of the reach of children and do not allow persons unfamiliar with the power tool or these instructions to operate the power tool.** Power tools are dangerous in the hands of untrained users.
- ▶ **Maintain power tools. Check for misalignment or binding of moving parts, breakage of parts and any other condition that may affect the power tool's operation. If damaged, have the power tool repaired before use.** Many accidents are caused by poorly maintained power tools.
- ▶ **Keep cutting tools sharp and clean.** Properly maintained cutting tools with sharp cutting edges are less likely to bind and are easier to control.
- ▶ **Use the power tool, accessories and tool bits etc. in accordance with these instructions, taking into account the working conditions and the work to be performed.** Use of the power tool for operations different from those intended could result in a hazardous situation.

#### Service

- ▶ **Have your power tool serviced by a qualified repair person using only identical replacement parts.** This will ensure that the safety of the power tool is maintained.

## Safety Warnings for Table Saws

- ▶ **Never stand on the power tool.** Serious injuries can occur when the power tool tips over or when inadvertently coming into contact with the saw blade.
- ▶ **Take care that the blade guard operates properly and can move freely.** Always adjust the blade guard in such a manner that it faces loosely against the workpiece when sawing. Never clamp the blade guard when it is open.
- ▶ **Keep hands away from the cutting area while the machine is running.** Danger of injury when coming in contact with the saw blade.
- ▶ **Never reach behind the saw blade in order to hold the workpiece, remove saw dust/wood chips or for any other reason.** The clearance of your hand to the rotating saw blade is too small.
- ▶ **Guide the workpiece against the saw blade only when the machine is switched on.** Otherwise there is damage of kickback, when the saw blade becomes wedged in the workpiece.
- ▶ **Keep handles dry, clean, and free from oil and grease.** Greasy, oily handles are slippery causing loss of control.
- ▶ **Operate the power tool only when the work area to the workpiece is clear of any adjusting tools, wood chips, etc.** Small pieces of wood or other objects that come in contact with the rotating saw blade can strike the operator with high speed.
- ▶ **Only saw one workpiece at a time.** Workpieces placed on top or aside of each other can cause the saw blade to jam or the workpieces to move against each other while sawing.
- ▶ **Always use the parallel guide or the angle guide.** This improves the cutting accuracy and reduces the possibility of saw blade binding.
- ▶ **Use the machine for grooving or rebating only with an appropriately suitable protective device (e. g. a tunnel blade guard).**
- ▶ **Do not use the machine for cutting slots (stopped grooves).**
- ▶ **Use the machine only for cutting the materials listed under Intended Use.** Otherwise, the machine can be subject to overload.
- ▶ **If the saw blade should become jammed, switch the machine off and hold the workpiece until the saw blade comes to a complete stop. To prevent kickback, the workpiece may not be moved until after the machine has come to a complete stop.** Correct the cause for the jamming of the saw blade before restarting the machine.
- ▶ **Do not use dull, cracked, bent or damaged saw blades.** Unsharpened or improperly set saw blades produce narrow kerf causing excessive friction, blade binding and kickback.
- ▶ **Always use blades with correct size and shape (diamond versus round) of arbour holes.** Blades that do not match the mounting hardware of the saw will run eccentrically, causing loss of control.

- ▶ **Do not use high speed steel (HSS) saw blades.** Such saw blades can easily break.
- ▶ **Do not touch the saw blade after working before it has cooled.** The saw blade becomes very hot while working.
- ▶ **Keep your workplace clean.** Blends of materials are particularly dangerous. Dust from light alloys can burn or explode.
- ▶ **Never operate the machine without the insert plate. Replace a defective insert plate.** Without flawless insert plates, injuries are possible from the saw blade.
- ▶ **Check the cable regularly and have a damaged cable repaired only through an authorised customer service agent for Bosch power tools. Replace damaged extension cables.** This will ensure that the safety of the power tool is maintained.
- ▶ **Store the machine in a safe manner when not being used. The storage location must be dry and lockable.** This prevents the machine from storage damage, and from being operated by untrained persons.
- ▶ **Never leave the machine before it has come to a complete stop.** Cutting tools that are still running can cause injuries.
- ▶ **Never use the machine with a damaged cable. Do not touch the damaged cable and pull the mains plug when the cable is damaged while working.** Damaged cables increase the risk of an electric shock.

**Products sold in GB only:** Your product is fitted with a BS 1363/A approved electric plug with internal fuse (ASTA approved to BS 1362).

If the plug is not suitable for your socket outlets, it should be cut off and an appropriate plug fitted in its place by an authorised customer service agent. The replacement plug should have the same fuse rating as the original plug.

The severed plug must be disposed of to avoid a possible shock hazard and should never be inserted into a mains socket elsewhere.

**Products sold in AUS and NZ only:** Use a residual current device (RCD) with a rated residual current of 30 mA or less.

## Symbols

The following symbols can be important for the operation of your power tool. Please memorise the symbols and their meanings. The correct interpretation of the symbols helps you operate the power tool better and more secure.

### Symbols and their meaning



**Keep hands away from the cutting area while the machine is running.** Danger of injury when coming in contact with the saw blade.



**Wear a dust respirator.**

### Symbols and their meaning



**Wear ear protectors.** Exposure to noise can cause hearing loss.



**Wear safety goggles.**

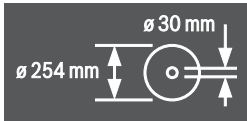

Observe the dimensions of the saw blade. The hole diameter must match the tool spindle without play. Do not use reducers or adapters.

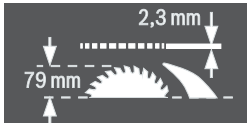

When changing the saw blade, pay attention that the kerf width is not less than 2.3 mm and the blade body thickness not greater than 2.3 mm. Otherwise, there is danger that the riving knife (2.3 mm) becomes wedged in the workpiece.

The maximal possible workpiece height is 79 mm.

Left side

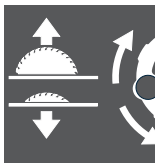

Indicates the rotation direction of the handwheel for lowering (**transport position**) and raising (**working position**) the saw blade.

Right side



Indicates the position of the locking lever for locking the saw blade and for adjusting the bevel angle (saw blade tiltable).

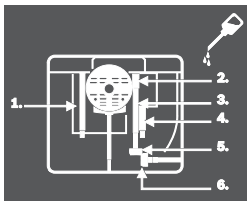

If required, lubricate the power tool at the indicated locations.

## Product Description and Specifications



**Read all safety warnings and all instructions.** Failure to follow the warnings and instructions may result in electric shock, fire and/or serious injury.

### Intended Use

The power tool is intended as a stationary machine for making straight lengthways and crossways cuts in hard and soft wood, as well as in particle and fibre board. In this, mitre angles from  $-60^\circ$  to  $+60^\circ$  as well as bevel angles from  $-2^\circ$  to  $47^\circ$  are possible.

When using appropriate saw blades, sawing aluminium profiles and plastic is also possible.

### Product Features

The numbering of the components shown refers to the representation of the power tool on the graphic pages.

- 1 Scale for clearance of the saw blade to the parallel guide **10**
- 2 Guide groove for parallel guide **10**
- 3 Angle stop
- 4 Recessed handles
- 5 Guide groove for angle stop
- 6.1 Blade guard with clamping lever\*
- 6.2 Blade guard with clamping screw and side protector\*
- 7 Vacuum connection on the blade guard
- 8.1 Clamping lever for locking blade guard **6.1**
- 8.2 Clamping screw for locking blade guard **6.2**
- 9 Saw table
- 10 Parallel guide
- 11 V-guide groove on saw table for parallel guide
- 12 Mounting holes
- 13 Carrying handle
- 14 Saw-table extension
- 15 Tensioning lever for saw-table extension
- 16 Fastening bracket for saw stand GTA 600
- 17 Locking lever for adjustment of bevel angles
- 18 Handwheel
- 19 Crank for lowering and raising the saw blade
- 20 Safety flap of On/Off switch
- 21 Hex key (5 mm)
- 22 Ring spanner (23 mm)
- 23 Push stick
- 24 Insert plate
- 25 Riving knife
- 26 Saw blade
- 27 Lens
- 28 Profile rail
- 29 Cable holder

## 30 | English

- 30 Retaining bracket for storage of the auxiliary parallel guide
- 31 Chip ejector
- 32 Extraction adapter
- 33 Fixture for storage of the blade guard
- 34 Insert-plate notches
- 35 Clamping handle of the parallel guide
- 36 V-guide of parallel guide
- 37 Auxiliary parallel guide
- 38 "Auxiliary parallel guide" fastening kit
- 39 Guide rail of the angle stop
- 40 "Profile rail" fastening kit
- 41 Fastening screw for chip ejector
- 42 Clamping nut
- 43 Spindle lock lever
- 44 Clamping flange
- 45 Tool spindle
- 46 Mounting flange
- 47 Indicator for bevel angle
- 48 Scale for bevel angle
- 49 Locking knob for various mitre angles
- 50 Angle indicator on the angle guide
- 51 Saw-table clearance indicator
- 52 ON button
- 53 Knurled nut for profile rail
- 54 Cross-head screw for adjustment of stop 55
- 55 Stop for 0° bevel angle
- 56 Screw for bevel angle indicator
- 57 Cross-head screw for adjustment of stop 58
- 58 Stop for 45° bevel angle
- 59 Front hex socket screws (5 mm) for parallelism adjustment of the saw blade
- 60 Rear hex socket screws (5 mm) for parallelism adjustment of the saw blade
- 61 Screw for saw-table clearance indicator
- 62 Screw for parallel guide clearance indicator
- 63 Adjusting screws for insert plate
- 64 Hex key (2 mm)
- 65 Holder for storage of "auxiliary parallel guide fastening kit"
- 66 Retaining clamp for storage of the extraction adapter
- 67 Fastening nut for the ring spanner and for attaching the push stick
- 68 Holder for storage of the hex key
- 69 Retaining clamp for storage of the angle stop
- 70 Adjustment screw for tightening tension of guide 36
- 71 Hex socket screws (5 mm) for parallelism adjustment of the parallel guide

\* depending on country version

Accessories shown or described are not part of the standard delivery scope of the product. A complete overview of accessories can be found in our accessories program.

## Technical Data

Table saw	GTS 10 J	
Article number	...	500
3 601 M30 ...	...	530
	...	570
	...	590
	...	5P0
	...	5R0
	...	560
Rated power input	W	1800 1650
No-load speed	min <sup>-1</sup>	3650 3650
Reduced starting current		● ●
Weight according to EPTA-Procedure 01/2003	kg	26 26
Protection class		□/II □/II
Dimensions (incl. removable product features)		
Width x depth x height	mm	578 x 706 x 330
Maximum workpiece dimensions, see page 34.		
The values given are valid for a nominal voltage [U] of 230 V. For different voltages and models for specific countries, these values can vary.		

## Dimension of suitable saw blades

Saw blade diameter	mm	254
Blade body thickness	mm	1.7 - 1.9
Tooth thickness/setting, min.	mm	2.6
Mounting hole diameter	mm	30

## Noise Information

Sound emission values determined according to EN 61029-2-1.

Typically the A-weighted noise levels of the product are: Sound pressure level 103 dB(A); Sound power level 116 dB(A). Uncertainty K = 3 dB.

**Wear hearing protection!**

Declaration of Conformity **CE**

We declare under our sole responsibility that the product described under "Technical Data" is in conformity with all relevant provisions of the directives 2011/65/EU, 2004/108/EC, 2006/42/EC including their amendments and complies with the following standards: EN 61029-1, EN 61029-2-1.

EC Type Examination No. MSR 1034 by notified testing agency No. 0366.

Technical file (2006/42/EC) at:  
Robert Bosch GmbH, PT/ETM9,  
70764 Leinfelden-Echterdingen, GERMANY

Henk Becker	Helmut Heinzelmann
Executive Vice President	Head of Product Certification
Engineering	PT/ETM9

*PPA*  
*Henk Becker* i.v. *Helmut Heinzelmann*

Robert Bosch GmbH, Power Tools Division  
70764 Leinfelden-Echterdingen, GERMANY  
Leinfelden, 28.01.2015



## Assembly

- ▶ **Avoid unintentional starting of the machine. During assembly and for all work on the machine, the power plug must not be connected to the mains supply.**

### Delivery Scope



Please also observe the representation of the delivery scope at the beginning of the operating instructions.

Before starting the operation of the machine for the first time, check if all parts listed below have been supplied:

- Table saw with mounted saw blade **26** and riving knife **25**
- Angle stop **3**
- Profile rail **28**
- Fastening kit “profile rail” **40** (guide plate, knurled nut, screw, washer)
- Parallel guide **10**
- Auxiliary parallel guide **37**
- “Auxiliary parallel guide” fastening kit **38** (3 fastening screws, 3 washers, 3 wing nuts)
- Blade guard **6.x\***  
\* depending on country version: **6.1/6.2**
- Hex key **21**
- Hex key **64**
- Ring spanner **22**
- Push stick **23**
- Insert plate **24**
- Extraction adapter **32**

**Note:** Check the power tool for possible damage.

Before further use of the machine, check that all protective devices are fully functional. Any lightly damaged parts must be carefully checked to ensure flawless operation of the tool. All parts must be properly mounted and all conditions fulfilled that ensure faultless operation.

Damaged protective devices and parts must be immediately replaced by an authorised service centre.

### Mounting Individual Components

- Carefully remove all parts included in the delivery from their packaging.  
Remove all packaging material from the machine and the accessories provided.
- Take care that the packaging material under the motor block es removed.

The following product features are fastened directly to the housing:

Push stick **23**, ring spanner **22**, hex key **21** and **64**, parallel guide **10**, angle guide **3**, extraction adapter **32**, auxiliary parallel guide **37** with fastening kit **38**, blade guard **6.x**.

- Carefully remove these product features from their storage locations.  
Also see figures Y1 – Y6.

### Mounting the Insert Plate (see figure A)

- Hook insert plate **24** into the rear insert-plate notches **34** of the tool basin.
- Guide the insert plate down.
- Press on the insert plate until it engages at the front in the tool basin.

The front side of the insert plate **24** must be flush with or somewhat lower than the saw table; the rear side must be flush with or somewhat above the saw table. (also see “Adjusting the Level of the Insert Plate”, page 36)

### Mounting the Blade Guard\* (see figure B) \* depending on country version

- Turn crank **19** clockwise to the stop, so that the saw blade **26** is in the highest possible position above the saw table.
- Pull the riving knife **25** upward to the stop.
- Insert the blade guard **6.x** into the recess in riving knife **25**.
- Tighten the clamping lever **8.1**.

or

Tighten clamping screw **8.2** with hex key **21**.

- Adjust the blade guard according to the workpiece height. When sawing, the blade guard must always face lightly against the workpiece.

**Note:** Clamping lever **8.1** is indexed (adjustable), allowing it to be set to an ergonomically favourable or space-saving position.

With the clamping lever tightened, pull its lever away from the blade guard, turn it to the desired position and allow it to engage again.

### Mounting the Parallel Guide (see figure C)

The parallel guide **10** can be positioned either left or right from the saw blade.

- Loosen clamping handle **35** of parallel guide **10**.  
This releases V-guide **36**.
- Firstly, mount the parallel guide via the V-guide in guide groove **11** of the saw table. Now, position the parallel guide into the front guide groove **2** of the saw table.  
The parallel guide can now be moved to any position.
- To lock the parallel guide, press the clamping handle **35** down.

### Mounting the Auxiliary Parallel Guide (see figure D)

**When sawing narrow workpieces and bevel angles**, the auxiliary parallel guide **37** must be mounted to parallel guide **10**.

The auxiliary parallel guide can be mounted left or right from parallel guide **10**, as required.

For assembly, use the “auxiliary parallel guide” fastening kit **38**. (3 fastening screws, 3 washers, 3 wing nuts)

- Insert the fastening screws through the lateral holes in the parallel guide **10**.  
The heads of the screws serve as a guide for the auxiliary parallel guide.
- Move the auxiliary parallel guide **37** over the heads of the fastening screws.
- Mount the washers to the fastening screws and tighten them with the wing nuts.

## 32 | English

**Mounting the Angle Stop (see figures E1 – E2)**

- Insert the guide rail **39** of the angle stop **3** into one of the guide grooves **5** of the saw table intended for this purpose.

For improved placement of long workpieces, the angle stop can be extended with profile rail **28**.

- If required, mount the profile rail to the angle stop with fastening kit **40**.

**Dust/Chip Extraction**

Dusts from materials such as lead-containing coatings, some wood types, minerals and metal can be harmful to one's health. Touching or breathing-in the dusts can cause allergic reactions and/or lead to respiratory infections of the user or bystanders.

Certain dusts, such as oak or beech dust, are considered as carcinogenic, especially in connection with wood-treatment additives (chromate, wood preservative). Materials containing asbestos may only be worked by specialists.

- Always use dust extraction.
- Provide for good ventilation of the working place.
- It is recommended to wear a P2 filter-class respirator.

Observe the relevant regulations in your country for the materials to be worked.

The dust/chip extraction can be blocked by dust, chips or workpiece fragments.

- Switch the machine off and pull the mains plug from the socket outlet.
- Wait until the saw blade has come to a complete stop.
- Determine the cause of the blockage and correct it.

► **Prevent dust accumulation at the workplace.** Dusts can easily ignite.

► **To avoid the danger of fire when sawing aluminium, empty the sawdust ejector and do not work with dust/chip extraction.**

**Emptying the Chip Ejector (see figure F)**

The sawdust ejector **31** can be emptied for removal of workpiece fragments and large chips.

- Switch the machine off and pull the mains plug from the socket outlet.
- Wait until the saw blade has come to a complete stop.
- Loosen fastening screw **41** with hex key **21**.
- Pull out chip ejector **31** and remove workpiece fragments and chips.
- Mount the chip ejector to the power tool again.

**External Dust Extraction (see figure G)**

To connect a vacuum cleaner to the sawdust ejector **31**, use the supplied extraction adapter **32**.

- Firmly attach the extraction adapter **32** and the vacuum hose.
- Additionally, a dust extraction system can be connected with the Y-adapter (accessory) to vacuum connection **7**, to increase the extraction performance.

The vacuum cleaner must be suitable for the material being worked.

When vacuuming dry dust that is especially detrimental to health or carcinogenic, use a special vacuum cleaner.

**Stationary or Flexible Mounting**

► **To ensure safe handling, the machine must be mounted on a level and stable surface (e. g., workbench) prior to using.**

**Mounting to a Working Surface (see figure H)**

- Fasten the power tool with suitable screw fasteners to the working surface. The mounting holes **12** serve for this purpose.

**Mounting to a Bosch Saw Stand (see figure I)**

With the height-adjustable legs, Bosch saw stands (e. g. GTA 60 W, GTA 600) provide firm support for the power tool on any surface.

► **Read all safety warnings and instructions included with the worktable.** Failure to observe safety warnings and instructions can lead to electrical shock, fire and/or cause serious injuries.

► **Assemble the worktable properly before mounting the power tool.** Perfect assembly is important in order to prevent the risk of collapsing.

- Mount the power tool in transport position on the saw stand.

**Changing the Saw Blade (see figures J1 – J4)**

► **Before any work on the machine itself, pull the mains plug.**

► **When mounting the saw blade, wear protective gloves.** Danger of injury when touching the saw blade.

Use only saw blades whose maximum permitted speed is higher than the no-load speed of the power tool.

Use only saw blades that correspond with the characteristic data given in these operation instructions and that are tested and marked in accordance with EN 847-1.

Use only saw blades recommended by the tool manufacturer and suitable for sawing the materials to be cut.

**Removing the Saw Blade**

- Using a screwdriver, raise the insert plate **24** at the front and remove it from the tool basin.
- Turn crank **19** clockwise to the stop, so that the saw blade **26** is in the highest possible position above the saw table.
- Tilt the blade guard **6.x** toward the rear to the stop.
- Turn the clamping nut **42** with the ring spanner **22** (23 mm) and at the same time, pull the spindle lock lever **43** until it engages.
- Keep the spindle lock lever pulled and unscrew the clamping nut turning in anticlockwise direction.
- Remove the clamping flange **44**.
- Remove the saw blade **26**.

**Mounting the Saw Blade**

If required, clean all parts to be mounted prior to assembly.

- Place the new saw blade onto the supporting flange **46** of the tool spindle **45**.

**Note:** Do not use saw blades that are too small. The clearance between saw blade and riving knife must not exceed 5 mm (max.).



► **When mounting the saw blade, pay attention that the cutting direction of the teeth (arrow direction on the saw blade) corresponds with the direction of the arrow on the blade guard!**

- Mount the clamping flange **44** and the clamping nut **42**.
- Turn the clamping nut **42** with the ring spanner **22** (23 mm) and at the same time, pull the spindle lock lever **43** until it engages.
- Tighten the clamping nut in clockwise direction (Tightening torque approx. 15 – 23 Nm).
- Reinsert the insert plate **24**.
- Tilt blade guard **6.x** down again.

## Operation

► **Before any work on the machine itself, pull the mains plug.**

### Transport and Working Position of the Saw Blade

#### Transport Position

- Turn the handwheel **18** in anticlockwise direction until the teeth of the saw blade **26** are positioned below the saw table **9**.
- Slide the table extension **14** completely inward. Press tensioning lever **15** downward. The saw-table extension is now locked.

For additional information on transport, see page 36.

#### Working Position

- Turn the crank **19** clockwise, until the teeth of the saw blade **26** are positioned above the workpiece.

**Note:** Take care that the blade guard is properly positioned. When sawing, it must always face against the workpiece.

### Adjusting the Cutting Angle

To ensure precise cuts, the basic adjustment of the machine must be checked and adjusted as necessary after intensive use (see “Checking and Adjusting the Basic Adjustment”, page 35).

#### Adjusting Bevel Angles (Saw Blade) (see figure K)

The bevel angle can be set in the range from  $-2^{\circ}$  to  $47^{\circ}$ .

- Turn locking lever **17** in anticlockwise direction.

**Note:** By completely loosening the locking knob, the saw blade tilts approx. to the  $30^{\circ}$  position by means of gravity force.

- Push or pull handwheel **18** alongside the connecting link until the angle indicator **47** indicates the desired bevel angle.
- Hold the handwheel in this position and tighten locking lever **17** again.

**For quick and precise setting of the standard  $0^{\circ}$  and  $45^{\circ}$  angles, factory-set stops have been provided for.**

### Adjusting Mitre Angles (Angle Stop) (see figure L)

The mitre angle can be set in the range from  $60^{\circ}$  (left side) to  $60^{\circ}$  (right side).

- Loosen the locking knob **49** in case it is tightened.
- Turn the angle stop until the angle indicator **50** indicates the requested mitre angle.
- Tighten the locking knob **49** again.

### Increasing the Size of the Saw Table (see figure M)

Long workpieces must be underlaid or supported at their free end.

- Completely pull tensioning lever **15** of the saw-table extension upward.
- Pull out the saw-table extension **14** to the desired length.
- Press tensioning lever **15** downward. The saw-table extension is now locked.

### Adjusting the Parallel Guide

The parallel guide **10** can be positioned either left (black scale) or right (silver scale) from the saw blade. The mark in the lens **27** indicates the set clearance of the parallel guide to the saw blade on the scale **1**.

Position the parallel guide on the desired side of the saw blade (see “Mounting the Parallel Guide”, page 31).

#### With the Saw Table not Extended

- Loosen clamping handle **35** of parallel guide **10**. Move the parallel guide until the mark in the lens **27** indicates the desired clearance to the saw blade. When the saw table is not extended, the bottom labelling of the silver scale applies **1**.
- To lock the parallel guide, press clamping handle **35** down again.

#### With the Saw Table Extended (see figure N)

- Position the parallel guide on the right side of the saw blade. Move the parallel guide until the mark in the lens **27** indicates 26 cm on the bottom scale. To lock the parallel guide, press clamping handle **35** down again.
- Completely pull tensioning lever **15** of the saw-table extension upward.
- Pull saw-table extension **14** outward until clearance indicator **51** indicates the desired clearance to the saw blade on the top scale.
- Press tensioning lever **15** downward. The saw-table extension is now locked.

## 34 | English

## Adjusting the Auxiliary Parallel Guide (see figure O)

When sawing narrow workpieces and bevel angles, the auxiliary parallel guide **37** must be mounted to parallel guide **10**.

The auxiliary parallel guide can be mounted left or right to parallel guide **10** as required.

When sawing workpieces, these can become jammed between the parallel guide and the saw blade, be caught by the rotating saw blade, and be thrown from the machine.

Therefore, adjust the auxiliary parallel guide in such a manner that its guiding end is located between the front saw blade tooth and the front edge of the riving knife.

- For this, loosen all wing nuts and move the auxiliary parallel guide until only the two front screws can be used for fastening.
- Tighten the wing nuts again.

## Adjusting the Riving Knife

The riving knife **25** prevents the saw blade **26** from becoming jammed in the saw cut. Otherwise, there is danger of kickback when the saw blade becomes wedged in the workpiece.

Always pay attention that the riving knife is properly adjusted:

- The radial clearance between saw blade and riving knife may not exceed 5 mm (max.).
- The thickness of the riving knife must be smaller than the cutting width and greater than the blade thickness.
- The riving knife must always be in a line to the saw blade.
- For normal separating cuts, the riving knife must always be in the highest possible position.

The machine is supplied with the riving knife correctly adjusted.

## Adjusting the height of the riving knife (see figure P)

For sawing grooves, the height of the riving knife must be adjusted.

- ▶ **Use the machine for grooving or rebating only with an appropriately suitable protective device (e. g. a tunnel blade guard).**

- Loosen clamping lever **8.1** or clamping screw **8.2** until blade guard **6.x** can easily be pulled from the recess in riving knife **25**.

To protect the blade guard against damage, deposit it in the provided holding fixture **33** on the housing (also see figure Y1).

- Turn crank **19** clockwise to the stop, so that the saw blade **26** is in the highest possible position above the saw table.
- Push the riving knife **25** down to the stop.

## Starting Operation

- ▶ **Observe the mains voltage!** The voltage of the power source must correspond with the data on the type plate of the machine.

## Switching On (see figure Q1)

To save energy, only switch the power tool on when using it.

- Tilt safety flap **20** upward.
- To start the operation, press the green ON button **52**.
- Tilt safety flap **20** down again.

## Switching Off (see figure Q2)

- Press on the safety flap **20**.

## Power Failure

The ON/OFF switch is a so-called non-voltage switch, which prevents the power tool from restarting after a power failure (e. g., when the mains plug is pulled during operation).

To restart the operation of the machine afterwards, the green ON button **52** must be pressed again.

## Working Advice

### General Sawing Instructions

- ▶ **For all cuts, it must first be ensured that the saw blade at no time can come in contact with the stops or other machine parts.**
- ▶ **Use the machine for grooving or rebating only with an appropriately suitable protective device (e. g. a tunnel blade guard).**
- ▶ **Do not use the machine for cutting slots (stopped grooves).**

Protect the saw blade against impact and shock. Do not subject the saw blade to lateral pressure.

The riving knife must be in alignment with the saw blade to avoid jamming of the workpiece.

Do not saw warped/bent workpieces. The workpiece must always have a straight edge to face against the parallel guide.

Always keep/store the push stick with the power tool.

### Position of the Operator (see figure R)

- ▶ **Do not stand in a line with the saw blade in front of the machine. Always stand aside of the saw blade.** This protects your body against possible kickback.

- Keep hands, fingers and arms away from the rotating saw blade.

Observe the following instructions:

- Hold the workpiece securely with both hands and press it firmly against the saw table.
- When sawing narrow workpieces and bevel angles, always use the supplied hold-down stick **23** and the auxiliary parallel guide **37**.

### Maximum Workpiece Dimensions

Bevel angle	Max. workpiece height [mm]
0°	79
45°	56

## Sawing

### Sawing Straight Cuts

- Adjust the parallel guide **10** to the requested cutting width. (see "Adjusting the Parallel Guide", page 33)
- Position the workpiece on the saw table in front of the blade guard **6.x**.
- Raise or lower the saw blade with the crank **19** so that the upper saw teeth project approx. 5 mm above the workpiece surface.

- Adjust the blade guard according to the workpiece height. When sawing, the blade guard must always face lightly against the workpiece.
- Switch on the machine.
- Saw through the workpiece applying uniform feed.
- Switch off the machine and wait until the saw blade has come to a complete stop.

#### Sawing Bevel Angles

- Adjust the desired bevel angle. (see "Adjusting Bevel Angles", page 33)
- Follow the worksteps in section "Sawing Straight Cuts" accordingly.

#### Sawing Mitre Angles (see figure S)

- Adjust the requested mitre angle. (see "Adjusting Mitre Angles", page 33)
- Place the workpiece against profile rail **28**. The profile may not be on the cutting line. If so, loosen knurled nut **53** and move the profile.
- Raise or lower the saw blade with the crank **19** so that the upper saw teeth project approx. 5 mm above the workpiece surface.
- Adjust the blade guard according to the workpiece height. When sawing, the blade guard must always face lightly against the workpiece.
- Switch on the machine.
- With one hand, press the workpiece against the profile rail and with the other hand, slowly move the angle stop via locking knob **49** toward the front in guide groove **5**.
- Switch off the machine and wait until the saw blade has come to a complete stop.

#### Checking and Adjusting the Basic Adjustment

To ensure precise cuts, the basic adjustment of the machine must be checked and adjusted as necessary after intensive use. A certain level of experience and appropriate specialty tools are required for this.

A Bosch after-sales service station will handle this maintenance task quickly and reliably.

#### Setting the Stops for Standard 0° / 45° Bevel Angles

- Bring the power tool into the working position.
- Adjust to a 0° bevel angle.
- Tilt the blade guard **6.x** toward the rear to the stop.

#### Checking: (see figure T1)

- Set an angle gauge to 90° and place it on the saw table **9**.

The leg of the angle gauge must be flush with the saw blade **26** over the complete length.

#### Adjusting: (see figure T2)

- Loosen screw **54**. The 0° stop **55** can now be moved.
- Loosen locking lever **17**.
- Move handwheel **18** toward the 0° stop until the leg of the angle gauge is flush with the saw blade over the complete length.
- Hold the handwheel in this position and tighten locking lever **17** again.
- Tighten screw **54** again.

When the angle indicator **47** is not in line with the 0° mark of scale **48**, loosen screw **56** with a commercially available cross-head screwdriver and align the angle indicator alongside the 0° mark.

Repeat the above mentioned worksteps accordingly for the 45° bevel angle (loosening screw **57**; moving the 45° stop **58**). In this, the angle indicator **47** must not be misadjusted.

#### Parallelism of the Saw Blade to the Guide Grooves of the Angle Stop (see figure U)

- Bring the power tool into the working position.
- Tilt the blade guard **6.x** toward the rear to the stop.

#### Checking:

- With a pencil, mark the first visible saw tooth on the left side that projects above the insert plate.
- Set an angle gauge to 90° and place it on the edge of the guide groove **5**.
- Move the leg of the angle gauge until it touches the marked saw tooth, and read the clearance between saw blade and guide groove.
- Turn the saw blade until the marked tooth projects above the right side of the insert plate.
- Move the angle gauge alongside the guide groove to the marked tooth.
- Measure the clearance between the saw blade and guide groove again.

Both clearances measured must be identical.

#### Adjusting:

- Loosen hex socket screws **59** at the front below the saw table and hex socket screws **60** at the rear below the saw table with the supplied hex key **21**.
- Carefully move the saw blade until it is parallel to guide groove **5**.
- Retighten all screws **59** and **60** again.

#### Adjusting the Saw Table's Clearance Indicator (see figure V)

- Position the parallel guide on the right side of the saw blade. Move the parallel guide until the mark in the lens **27** indicates 26 cm on the bottom scale. To lock the parallel guide, press clamping handle **35** down again.
- Loosen tensioning lever **15** and pull the table extension out to the stop.

#### Checking:

On the upper scale **1**, clearance indicator **51** must indicate the identical value as the mark in lens **27** on the bottom scale **1**.

#### Adjusting:

- Loosen screw **61** with a cross-head screwdriver and align clearance indicator **51** alongside the 26 cm mark of the upper scale **1**.

## 36 | English

**Adjusting the Parallelism of the Parallel Guide (see figure W)**

- Bring the power tool into the working position.
- Tilt the blade guard **6.x** toward the rear to the stop.
- Loosen the clamping handle **35** of the parallel guide and slide it until it touches the saw blade.

**Checking:**

The parallel guide **10** must touch the saw blade over the complete length.

**Adjusting:**

- Loosen the hex socket screws **71** using the supplied hex key **21**.
- Carefully move the parallel guide **10** until it touches the saw blade over the complete length.
- Hold the parallel guide in this position and press the clamping handle **35** down again.
- Retighten the hex socket screws **71**.

**Adjusting the Tension Force of the Parallel Guide**

The tensioning force of the parallel guide **10** can decrease after frequent usage.

- Tighten the adjustment screw **70** until the parallel guide can be firmly affixed on the saw table again.

**Adjusting the Lens of the Parallel Guide (see figure W)**

- Bring the power tool into the working position.
- Tilt the blade guard **6.x** toward the rear to the stop.
- Move parallel guide **10** from the right until it touches the saw blade.

**Checking:**

The mark of lens **27** must be in a line with the 0° mark of scale **1**.

**Adjusting:**

- Loosen screw **62** using a cross-head screwdriver and align the clearance indicator alongside the 0° mark.

**Adjusting the Level of the Insert Plate (see figure X)****Checking:**

The front side of the insert plate **24** must be flush with or somewhat lower than the saw table; the rear side must be flush with or somewhat above the saw table.

**Adjusting:**

- Remove the insert plate **24**.
- Adjust the correct level of the four adjusting screws **63** with the hex key **64**.

**Storage and Transport****Storing Product Features (see figures Y1 – Y6)**

For storage purposes, certain product features can be securely fastened to the power tool.

- Loosen auxiliary parallel guide **37** from parallel guide **10**.
- Attach all loose tool parts to their storage locations on the housing. (see Table)

Figure	Product Feature	Storage Location
Y1	Blade guard <b>6.x</b>	Insert into the recess of fixture <b>33</b> and tighten with clamping lever <b>8.1</b> or clamping screw <b>8.2</b>
Y2	"Auxiliary parallel guide" fastening kit <b>38</b>	Clip into the holders <b>65</b>
Y2	Extraction adapter <b>32</b>	Insert into retaining clamp <b>66</b>
Y3	Ring spanner <b>22</b>	Fasten in tool depot with fastening nut <b>67</b>
Y3	Push stick <b>23</b>	Mount onto fastening nut <b>67</b> and fasten by turning
Y4	Parallel guide <b>10</b>	Turn guide around and hang it into the guide rails from below; tighten clamping handle <b>35</b>
Y5	Hex key <b>21</b> Hex key <b>64</b>	Insert into holders <b>68</b>
Y5	Angle stop <b>3</b>	Insert into retaining clamp <b>69</b>
Y6	Auxiliary parallel guide <b>37</b>	Insert into retaining brackets <b>30</b> (short side goes on top; long side toward the rear)

**Carrying the Power Tool**

Before transporting the power tool, the following steps must be carried out:

- Bring the machine into the transport position (see "Transport Position", page 33).
- Remove all accessories that cannot be mounted firmly to the power tool.  
If possible, place unused saw blades in an enclosed container for transport.
- Slide the saw-table extension **14** completely inward and press tensioning lever **15** downward to lock it.
- Wind the mains cable around the cable holder **29**.
- For lifting or transport, use the recessed handles **4** or the carrying handle **13**.

► **When transporting the power tool, use only the transport devices and never use the protective devices.**

► **The power tool should always be carried by two persons in order to avoid back injuries.**

## Maintenance and Service

### Maintenance and Cleaning

- ▶ **Before any work on the machine itself, pull the mains plug.**

If the replacement of the supply cord is necessary, this has to be done by Bosch or an authorized Bosch service agent in order to avoid a safety hazard.

#### Cleaning

- For safe and proper working, always keep the power tool and its ventilation slots clean.
- Remove dust and chips after each working procedure by blowing out with compressed air or with a brush.

#### Power Tool Lubrication



##### Lubricants:

SAE 10/SAE 20 engine oil

- If required, lubricate the power tool at the indicated locations. (see figure Z)

An authorized Bosch after-sales service agent will carry out this work quickly and reliably.

#### Observe all applicable environmental regulations when disposing of old grease and solvents.

#### Measures for Noise Reduction

Measures on behalf of the manufacturer:

- Soft starting
- Delivery of the machine with a saw blade developed particularly for noise reduction

Measures on behalf of the user:

- Low-vibration assembly on a firm working surface
- Use of saw blades with noise-reducing functions
- Regular cleaning of saw blade and power tool

#### Accessories

	Article number
Dust bag	2 605 411 205
Y-adapter TSVH 3	2 610 015 513
Angle stop	2 610 015 507
Push stick	2 610 015 022
Saw stand GTA 60 W	0 601 B12 000
Saw stand GTA 600	0 601 B22 001

#### Saw blades for wood and plate materials, panels and strips/mouldings

Saw blade 254 x 30 mm, 40 teeth	2 608 640 443
Saw blade 254 x 30 mm, 60 teeth	2 608 640 444

### After-sales Service and Application Service

In all correspondence and spare parts order, please always include the 10-digit article number given on the type plate of the machine.

Our after-sales service responds to your questions concerning maintenance and repair of your product as well as spare parts. Exploded views and information on spare parts can also be found under:

#### **www.bosch-pt.com**

Bosch's application service team will gladly answer questions concerning our products and their accessories.

#### Great Britain

Robert Bosch Ltd. (B.S.C.)  
P.O. Box 98  
Broadwater Park  
North Orbital Road  
Denham  
Uxbridge  
UB 9 5HJ

At [www.bosch-pt.co.uk](http://www.bosch-pt.co.uk) you can order spare parts or arrange the collection of a product in need of servicing or repair.

Tel. Service: (0344) 7360109

E-Mail: [boschservicecentre@bosch.com](mailto:boschservicecentre@bosch.com)

#### Ireland

Origo Ltd.  
Unit 23 Magna Drive  
Magna Business Park  
City West  
Dublin 24  
Tel. Service: (01) 4666700  
Fax: (01) 4666888

#### Australia, New Zealand and Pacific Islands

Robert Bosch Australia Pty. Ltd.  
Power Tools  
Locked Bag 66  
Clayton South VIC 3169  
Customer Contact Center  
Inside Australia:  
Phone: (01300) 307044  
Fax: (01300) 307045  
Inside New Zealand:  
Phone: (0800) 543353  
Fax: (0800) 428570  
Outside AU and NZ:  
Phone: +61 3 95415555  
[www.bosch.com.au](http://www.bosch.com.au)

#### Republic of South Africa

##### Customer service

Hotline: (011) 6519600

##### Gauteng – BSC Service Centre

35 Roper Street, New Centre  
Johannesburg  
Tel.: (011) 4939375  
Fax: (011) 4930126  
E-Mail: [bsctools@icon.co.za](mailto:bsctools@icon.co.za)

38 | English

**KZN – BSC Service Centre**

Unit E, Almar Centre  
143 Crompton Street  
Pinetown  
Tel.: (031) 7012120  
Fax: (031) 7012446  
E-Mail: bsc.dur@za.bosch.com

**Western Cape – BSC Service Centre**

Democracy Way, Prosperity Park  
Milnerton  
Tel.: (021) 5512577  
Fax: (021) 5513223  
E-Mail: bsc@zsd.co.za

**Bosch Headquarters**

Midrand, Gauteng  
Tel.: (011) 6519600  
Fax: (011) 6519880  
E-Mail: rbsa-hq.pts@za.bosch.com

**Disposal**

The machine, accessories and packaging should be sorted for environmental-friendly recycling.

Do not dispose of power tools into household waste!

**Only for EC countries:**



According to the European Directive 2012/19/EU for Waste Electrical and Electronic Equipment and its implementation into national right, power tools that are no longer usable must be collected separately and disposed of in an environmentally correct manner.

**Subject to change without notice.**