

Erbauer®

+LITHIUM ION-



ERI603COM

2Year
Guarantee

18V COMBI DRILL

ERI603COM

Original Instructions
(Version 1.0)

Erbauer®

Congratulations on your purchase of a quality power tool from Erbauer (UK) Ltd. This product should give you reliable service but for your peace of mind this **Erbauer power tool does carry a 2 year guarantee, the terms of which are detailed below.**

If this product develops a fault within the guarantee period contact your retailer.

Please retain this handbook in case you need to refer to safety, care or guarantee information in the future.

GUARANTEE

This **Erbauer** product carries a 2 years guarantee. If your product develops a fault within this period, you should in the first instance contact the retailer where the item was purchased.

This guarantee specifically excludes losses caused due to:

- Fair wear and tear
- Misuse or abuse
- Lack of routine maintenance
- Failure of consumable items (such as batteries)
- Accidental damage
- Cosmetic damage
- Failure to follow manufacturer's guidelines
- Loss of use of the goods

This guarantee does not affect your statutory rights. This guarantee is only valid in the UK.

For further technical advice, spare parts or repair service (outside of guarantee) please contact the customer helpline number on 0345 607 6380.

General Power Tool Safety Warnings



WARNING! Read all safety warnings and all instructions. Failure to follow the warnings and instructions may result in electric shock, fire and/or serious injury.

Save all warnings and instructions for future reference.

The term “power tool” in the warnings refers to your mains-operated (corded) power tool or battery-operated (cordless) power tool.

1) Work area safety

a) Keep work area clean and well lit. Cluttered or dark areas invite accidents.

b) Do not operate power tools in explosive atmospheres, such as in the presence of flammable liquids, gases or dust. Power tools create sparks which may ignite the dust or fumes.

c) Keep children and bystanders away while operating a power tool. Distractions can cause you to lose control.

2) Electrical safety

a) Power tool plugs must match the outlet. Never modify the plug in any way. Do not use any adapter plugs with earthed (grounded) power tools. Unmodified plugs and matching outlets will reduce risk of electric shock.

b) Avoid body contact with earthed or grounded surfaces, such as pipes, radiators, ranges and refrigerators. There is an increased risk of electric shock if your body is earthed or grounded.

c) Do not expose power tools to rain or wet conditions. Water entering a power tool will increase the risk of electric shock.

d) Do not abuse the cord. Never use the cord for carrying, pulling or unplugging the power tool. Keep cord away from heat, oil, sharp edges or moving parts. Damaged or entangled cords increase the risk of electric shock.

e) When operating a power tool outdoors, use an extension cord suitable for outdoor use. Use of a cord suitable for outdoor use reduces the risk of electric shock.

f) If operating a power tool in a damp location is unavoidable, use a residual current device (RCD) protected supply. Use of an RCD reduces the risk of electric shock.

3) Personal safety

a) Stay alert, watch what you are doing and use common sense when operating a power tool. Do not use a power tool while you are tired or under the influence of drugs, alcohol or medication. A moment of inattention while operating power tools may result in serious personal injury.

b) Use personal protective equipment. Always wear eye protection. Protective equipment such as dust mask, non-skid safety shoes, hard hat, or hearing protection used for appropriate conditions will reduce personal injuries.

c) Prevent unintentional starting. Ensure the switch is in the off-position before connecting to power source and/or battery pack, picking up or carrying the tool. Carrying power tools with your finger on the switch or energising power tools that have the switch on invites accidents.

d) Remove any adjusting key or wrench before turning the power tool on. A wrench or a key left attached to a rotating part of the power tool may result in personal injury.

- e) **Do not overreach. Keep proper footing and balance at all times.** This enables better control of the power tool in unexpected situations.
- f) **Dress properly. Do not wear loose clothing or jewellery. Keep your hair, clothing and gloves away from moving parts.** Loose clothes, jewellery or long hair can be caught in moving parts.
- g) **If devices are provided for the connection of dust extraction and collection facilities, ensure these are connected and properly used.** Use of dust collection can reduce dust-related hazards.

4) Power tool use and care

- a) **Do not force the power tool.** Use the correct power tool for your application. The correct power tool will do the job better and safer at the rate for which it was designed.
- b) **Do not use the power tool if the switch does not turn it on and off.** Any power tool that cannot be controlled with the switch is dangerous and must be repaired.
- c) **Disconnect the plug from the power source and/or the battery pack from the power tool before making any adjustments, changing accessories, or storing power tools.** Such preventive safety measures reduce the risk of starting the power tool accidentally.
- d) **Store idle power tools out of the reach of children and do not allow persons unfamiliar with the power tool or these instructions to operate the power tool.** Power tools are dangerous in the hands of untrained users.
- e) **Maintain power tools. Check for misalignment or binding of moving parts, breakage of parts and any other condition that may affect the power tool's operation. If damaged, have the power tool repaired before use.** Many accidents are caused by poorly maintained power tools.
- f) **Keep cutting tools sharp and clean.** Properly maintained cutting tools with sharp cutting edges are less likely to bind and are easier to control.
- g) **Use the power tool, accessories and tool bits etc. in accordance with these instructions, taking into account the working conditions and the work to be performed.** Use of the power tool for operations different from those intended could result in a hazardous situation.

5) Battery tool use and care

- a) **Recharge only with the charger specified by the manufacturer.** A charger that is suitable for one type of battery pack may create a risk of fire when used with another battery pack.
- b) **Use power tools only with specifically designated battery packs.** Use of any other battery packs may create a risk of injury and fire.
- c) **When battery pack is not in use, keep it away from other metal objects, like paper clips, coins, keys, nails, screws or other small metal objects, that can make a connection from one terminal to another.** Shorting the battery terminals together may cause burns or a fire.
- d) **Under abusive conditions, liquid may be ejected from the battery; avoid contact. If contact accidentally occurs, flush with water. If liquid contacts eyes, additionally seek medical help.** Liquid ejected from the battery may cause irritation or burns.

6) Service

- a) **Have your power tool serviced by a qualified repair person using only identical replacement parts.** This will ensure that the safety of the power tool is maintained.

ADDITIONAL SAFETY RULES FOR YOUR COMBI DRILL

- 1. Wear ear protectors when use impact drilling.** Exposure to noise can cause hearing loss.
- 2. Use auxiliary handle(s), if supplied with the tool.** Loss of control can cause personal injury.
- 3. Hold power tool by insulated gripping surfaces, when performing an operation where the cutting accessory may contact hidden wiring.** Cutting accessory contacting a "live" wire may make exposed metal parts of the power tool "live" and could give the operator an electric shock.
4. Remove the battery pack from the drill before carrying out adjustments.
5. Do not expose to rain or water.
6. Do not store the battery pack in temperatures over 40°C.
7. Always charge the battery pack between temperatures 0°C to 30°C. Ideal charging temperature is 18°C to 24°C.
8. Only use the charger and the battery pack provided no others.
9. Avoid short circuit of the battery pack connections (screws & nails).
10. Do not incinerate or burn the battery pack, it may explode.
11. Do not charge a damaged battery pack.
12. Replace any damaged supply cords on your charger.
13. Always disconnect the charger power supply before making or breaking the connections to the battery pack.
14. Battery pack and charger will be warm during charging this is normal.
15. When not in use, remove a charged battery pack from the charger.
16. Always remove the battery pack from the charger immediately after re-charging is completed.
17. Your drill and battery pack will be warm when working, this is normal.
18. Do not dispose of batteries in fire, or with household waste. Return exhausted batteries to your local collection or recycling point.
19. Always check walls, floors and ceilings for hidden power cables and pipes.
20. Accessories and metal parts can become very hot.

FOR CHARGER

1. This appliance can be used by children aged from 8 years and above and persons with reduced physical, sensory or mental capabilities or lack of experience and knowledge if they have been given supervision or instruction concerning use of the appliance in a safe way and understand the hazards involved. Children shall not play with the appliance. Cleaning and user maintenance shall not be made by children without supervision.
2. If the charger supply cord is damaged, it must be replaced by the manufacturer, its service agent or similarly qualified persons in order to avoid a hazard.
3. Charger is double insulated for additional electrical safety.
4. Charger is for indoor use only.
5. Never charge damaged batteries as these can short circuit and over heat.
6. When the charger is in use it **MUST** be supervised , if there is any evidence of overheating then **IMMEDIATELY** disconnect the charger from the power supply.
7. If gas or smoke is emitted from the battery during charging switch off the power supply , and move to a well vented area to allow the fumes to vent to atmosphere. Caution is there is leaking liquid from the battery wear protective clothing, glasses and clothes as this can be acidic.

8. Always disconnect battery charger and remove battery from charger when the charging is complete.
9. Only use the battery charger specifically stated on the base of the battery.

FOR BATTERY

1. Always remove the battery pack from the charger immediately after re-charging is completed.
2. When not in use, remove a charged battery pack from the charger.
3. Do not charge a damaged battery pack.
4. Do not charge non-rechargeable batteries.
5. Do not install the battery backwards so the polarity is reversed.
6. Do not connect the positive terminal and negative terminal of the battery to each other with any metal object (such as wire).
7. Do not carry or store battery together with necklaces, hairpins or other metal objects.
8. Do not pierce the battery with nails, strike the battery with a hammer, step on the battery or otherwise subject it to strong impacts or shocks.
9. Do not solder directly onto the battery.
10. Do not expose battery to water or salt water, or allow the battery to get wet.
11. Do not disassemble or modify the battery. The battery contains safety and protection devices, which, if damaged, may cause the battery to generate heat, explode or ignite. The protection circuit module provided with battery packs is not to be used as a substitute for a shut-off switch.
12. Do not place the battery in or near fire, on stoves or other high temperature locations. Do not place the battery in direct sunlight, or use or store the battery inside cars in hot weather. Heating the battery can damage the safety circuitry, which can cause additional heating, rupture or ignition of the battery. Using the battery in this manner may also result in a loss of performance and a shortened life expectancy.
13. Do not place the battery in microwave ovens, high-pressure containers or on induction cookware.
14. If you intend to store a battery for a period without use then store battery at room temperature (19°C to 25°C), charged to about 30 – 50% of capacity. When storing for very long periods boost-charge the battery once per year to prevent over discharge.
15. Always charge the battery in a temperature range of 0°C to 30°C and discharge in a temperature range of 0°C to 75°C.
16. The battery pack and charger will be warm during charging, this is normal.
17. Do not continue charging the battery if it does not recharge within the specified charging time. Doing so may cause the battery to become hot, explode or ignite. The temperature range over which the battery can be charged is 0°C to 30°C. Charging the battery at temperatures outside this range may cause severe damage to the battery or reduce battery life expectancy.
18. When the battery is worn out, insulate the terminals with adhesive tape or similar materials before disposal.
19. Do not dispose of batteries in fire, or with household waste. Return exhausted batteries to your local collection or recycling point.

 **Warning: If a small amount of electrolyte should leak from the battery pack under extremes of temperature or after heavy use, then wash off immediately from your skin and hands using clean water.** For eye contact, rinse thoroughly with clean water and seek medical treatment immediately.

ADDITIONAL SAFETY WARNING FOR CONSTRUCTION DUST

The updated Control of Substances Hazardous to Health Regulations 1st October 2012 now also targets to reduce the risks associated with silica, wood and gypsum dusts. Construction workers are one of the at-risk groups within this because of the dust that they breathe: silica dust is not just a nuisance; it is a real risk to your lungs!

Silica is a natural mineral present in large amounts in things like sand, sandstone and granite. It is also commonly found in many construction materials such as concrete and mortar. The silica is broken into very fine dust (also known as Respirable Crystalline Silica or RCS) during many common tasks such as cutting, drilling and grinding

Breathing in very fine particles of crystalline silica can lead to the development of:

Lung cancer

Silicosis

Chronic Obstructive Pulmonary Disorder (Chronic obstructive pulmonary disease (COPD))

And breathing in fine particles of wood dust can lead to the development of Asthma

The risk of lung disease is linked to people who regularly breathe construction dust over a period of time, not on the odd occasion.

To protect the lung, the COSHH Regulations sets a limit on the amount of these dusts that you can breathe (called a Workplace Exposure Limit or WEL) when averaged over a normal working day. These limits are not a large amount of dust: when compared to a penny it is tiny – like a small pinch of salt:

This limit is the legal maximum; the most you can breathe after the right controls have been used.

How to reduce the amount of dust?

- 1 Reduce the amount of cutting by using the best sizes of building products.
- 2 Use a less powerful tool e.g. a block cutter instead of angle grinder.
- 3 Using a different method of work altogether – e.g. using a nail gun to direct fasten cable trays instead of drilling holes first.

Please always work with approved safety equipment, such as those dust masks that specially designed to filter out microscopic particles and use the dust extraction facility at all time.

For more information please see the HSE website:

<http://www.hse.gov.uk/construction> or <http://www.hse.gov.uk/pubns/cis69.pdf>

 **Warning: Some dust particles created by power sanding, sawing, grinding, drill and other construction jobs contain chemicals known to cause cancer, birth defects or other reproductive harm.** Some examples of these chemicals are:

- Lead from lead-based paints.
- Crystalline silica from bricks and cement and other masonry products.
- Arsenic and chromium from chemically treated timber.

Your risk from these exposures varies, depending upon how often you do this type of work. To reduce your exposure to these chemicals:

- Work in a well-ventilated area.
- Work with approved safety equipment, such as those dust masks that are specially designed to filter microscopic particles.

VIBRATION

The European Physical Agents (Vibration) Directive has been brought in to help reduce hand arm vibration syndrome injuries to power tool users. The directive requires power tool manufacturers and suppliers to provide indicative vibration test results to enable users to make informed decisions as to the period of time a power tool can be used safely on a daily basis and the choice of tool.

Further Advice can be found at www.hse.gov.uk

Vibration total values (triax vector sum) determined according to EN 60745:	
Impact drilling into concrete	$a_{h,D}=11.4\text{m/s}^2$
	Uncertainty $K=1.5\text{m/s}^2$
Drilling into metal	$a_{h,D}=2.6\text{m/s}^2$
	Uncertainty $K=1.5\text{m/s}^2$

The declared vibration emission value should be used as a minimum level and should be used with the current guidance on vibration.

Calculating the actual period of the actual period off use can be difficult and the HSE website has further information.

The declared vibration emission been measured in accordance with a standardised test stated above and may be used to compare one tool with another tool.

The declared vibration emission value may also be used in a preliminary assessment of exposure.

 **Warning:** The vibration emission value during actual use of the power tool can differ from the declared value depending on the ways in which the tool is used dependant on the following examples and other variations on how the tool is used:

How the tool is used and the materials being cut or drilled.

The tool being in good condition and well maintained.

The use the correct accessory for the tool and ensuring it is sharp and in good condition.

The tightness of the grip on the handles.

And the tool is being used as intended by its design and these instructions.

While working with this power tool, hand/arm vibrations occur. Adopt the correct working practices in order to reduce the exposure to vibration.

This tool may cause hand-arm vibration syndrome if its use is not adequately managed.

 **Warning:** Identify safety measures to protect the operator that are based on an estimation of exposure in the actual conditions of use (taking account of all parts of the operating cycle such as the times when the tool is switched off and when it is running idle in addition to the trigger time). Note The use of other tools will reduce the users' total working period on this tool.

Helping to minimise your vibration exposure risk.

ALWAYS use sharp chisels, drills and blades.

Maintain this tool in accordance with these instructions and keep well lubricated (where appropriate).

Avoid using tools in temperatures of 10°C or less.

Plan your work schedule to spread any high vibration tool use across a number of days.

Health surveillance

All employees should be part of an employer's health surveillance scheme to help identify any vibration related diseases at an early stage, prevent disease progression and help employees stay in work.

Double insulation

The charger is double insulated. This means that all the external metal parts are electrically insulated from the mains power supply. This is done by placing insulation barriers between the electrical and mechanical components making it unnecessary for the tool to be earthed.

Vibration and noise reduction

To reduce the impact of noise and vibration emission, limit the time of operation, use low-vibration and low-noise operating modes as well as wear personal protective equipment. Take the following points into account to minimize the vibration and noise exposure risks:

1. Only use the product as intended by its design and these instructions.
2. Ensure that the product is in good condition and well maintained.
3. Use correct application tools for the product and ensure they in good condition.
4. Keep tight grip on the handles/grip surface.
5. Maintain this product in accordance with these instructions and keep it well lubricated (where appropriate).
6. Plan your work schedule to spread any high vibration tool use across a number of days.

Familiarise yourself with the use of this product by means of this instruction manual. Memorise the safety directions and follow them to the letter. This will help to prevent risks and hazards.

1. Always be alert when using this product, so that you can recognise and handle risks early. Fast intervention can prevent serious injury and damage to property.
2. Switch off and disconnect from the power supply if there is any malfunction. Have the product checked by a qualified specialist and repaired, if necessary, before you put it into operation again.

Residual risks

Even if you are operating this product in accordance with all the safety requirements, potential risks of injury and damage remain. The following dangers can arise in connection with the structure and design of this product:

1. Health defects resulting from vibration emission if the product is being used over long periods of time or not adequately managed and properly maintained.
2. Injuries and damage to property due to broken application tools or the sudden impact of hidden objects during use.
3. Danger of injury and property damage caused by flying objects.

 **Warning:** This product produces an electromagnetic field during operation! This field may under some circumstances interfere with active or passive medical implants! To reduce the risk of serious or fatal injury, we recommend persons with medical implants to consult their doctor and the medical implant manufacturer before operating this product!

Important note:

Be sure the supply is the same as the voltage given on the rating plate for the charger. The charger is fitted with a two-core cable and plug.

Remove the mains plug from socket before carrying out any adjustment or servicing.

SYMBOLS



To reduce the risk of injury, user must read instruction manual



Warning



Double insulation



Indoor use only



1h charging time for ERI606BAT



Do not expose to rain or water



Do not burn



Wear gloves



Always charge the battery pack between temperatures 0°C to 30°C. Ideal charging temperature is 18°C to 24°C.



This symbol indicates that this battery contains lithium. This battery shall be brought to your shop to be recycled.



Wear ear protection



Wear eye protection



Wear dust mask



Do not dispose of batteries, Return exhausted batteries to your local collection or recycling point.



Waste electrical products should not be disposed of with household waste. Please recycle where facilities exist. Check with your Local Authority or retailer for recycling advice.



yyWxx Manufacturing date code; Year of manufacturing (20yy) and week of manufacturing (Wxx);



-
1. KEYLESS CHUCK
 2. TORQUE ADJUSTMENT RING
 3. TWO-SPEED GEAR CONTROL
 4. FORWARD/REVERSE ROTATION CONTROL
 5. SOFT GRIP HANDLE
 6. BATTERY PACK *
 7. BATTERY PACK RELEASE BUTTON
 8. BELT HOOK
 9. ON/OFF SWITCH
 10. SIGHT LIGHT
-

* Not all the accessories illustrated or described are included in standard delivery.

TECHNICAL DATA

Voltage	18V  Max*	
No load speed	0-400/0-1400/min	
Impact rate	0-6400/0-22400bpm	
Number of clutch positions	21+1+1	
Max torque	40N.m	
Chuck capacity	13mm	
Charger Protection class	 /II	
Charging time	1hr	
Charger Input	100-240V~50/60Hz,78W	
Charger Output	14.4-20V 3000mA	
Max drilling capacity	Masonry	13mm
	Wood	35mm
	Steel	10mm
Machine weight	1.49 Kg	
Battery capacity	2.0Ah Li-ion battery	

NOISE INFORMATION

A weighted sound pressure	L_{PA} : 87.1dB(A)
A weighted sound power	L_{WA} : 98.1dB(A)
K_{PA} & K_{WA}	3.0dB(A)
Wear ear protection when sound pressure is over	80dB(A) 

ACCESSORIES

2.0 Ah Lithium Battery Pack(ERI606BAT)

1hr Charger (ERB607CHR)

Belt hook

2pcs

1pc

1pc

OPERATING INSTRUCTIONS



NOTE: Before using the tool, read the instruction book carefully.

INTENDED USE:

The machine is intended for driving in and loosening screws as well as for drilling in wood, metal and plastic.

BEFORE PUTTING INTO OPERATION

A) CHARGING THE BATTERY

The battery charger supplied is matched to the Li-ion battery installed in the machine. Do not use another battery charger.

The Li-ion battery is protected against deep discharging. When the battery is empty, the machine is switched off by means of a protective circuit: The tool holder no longer rotates.

In a warm environment or after heavy use, the battery pack may become too hot to permit charging. Allow time for the battery to cool down before recharging.

When the battery pack is charged for the first time and after prolonged storage, the battery pack will accept a 100% charge after several charge and discharge cycles.



Fig. 1-1



Fig. 1-2



Fig. 1-3

B) TO REMOVE THE BATTERY PACK (See Fig. 1-1)

Depress the Battery Pack Release Button firmly first and then slide the Battery Pack out from your tool.

C) TO INSTALL THE BATTERY PACK (See Fig. 1-2)

Slide the fully charged Battery Pack onto the tool with sufficient force until it clicks into position.

D) HOW TO CHARGE YOUR BATTERY PACK (See Fig. 1-3)

CHARGING PROCEDURE

- 1) Plug the charger into an appropriate outlet. The light will be green.
- 2) Slide the battery pack into the charger, the light will turn to red to indicate the charging process has started.
- 3) When charging is completed, the light will turn to green. The pack is now fully charged, unplug the charger and remove the battery pack.

**WARNING:**

When battery charge runs out after continuously use or exposure to direct sunlight or heat, allow time for the tool to cool down before re-charging to achieve the full charge.

CHARGING INDICATOR

This charger is designed to detect some problems that can arise with battery packs. Indicator lights indicate problems (see table below). If this occurs, insert a new battery pack to determine if the charger is OK. If the new battery charges correctly, then the original pack is defective and should be returned to a service center or recycling service center. If the new battery pack displays the same problem as the original Battery Pack, have the charger tested at an authorized service center.





Light	ON/OFF flash	Status
Red on 	————	Charging
Red flash 	- - - - -	Defective Battery
Green on 	————	Fully Charged
Green flash 	- - - - -	Hot/Cold Delay



Fig. 2-1

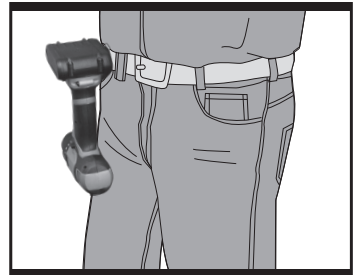

Fig. 2-2



Fig. 3

OPERATION**1. HOW TO USE THE BELT HOOK (See Fig. 2-1&2-2)**

Screw the Belt Hook on the tool with the screw provided in the plastic bag. The Belt Hook can be hooked on your belt or pocket, etc.

2. ON / OFF SWITCH (See Fig. 3)

Depress the On/Off switch to start and release it to stop your drill. The on/off switch is fitted with a brake function which stops your chuck immediately when you quickly release the switch.

It is also a variable speed switch that delivers higher speed and torque with increased trigger pressure. Speed is controlled by the amount of switch trigger depression.

 **WARNING: Do not operate for long periods at low speed because excess heat will be produced internally.**

3. SWITCH LOCK

The switch trigger can be locked in the OFF position. This helps to reduce the possibility of accidental starting when not in use. To lock the switch trigger, place the rotation control in the center position.



Fig. 4-1



Fig. 4-2



Fig. 5

4. REVERSIBLE (See Fig. 4-1&4-2)

For drilling and screw driving use forward rotation marked “<<” (lever is moved to the left). Only use reverse rotation marked “>>” (lever is moved to the right) to remove screws or release a jammed drill bit.

 **WARNING: Never change the direction of rotation when the chuck is rotating, wait until it has stopped!**

5. TWO-SPEED GEAR CONTROL (See Fig. 5)

The drill has a two-speed gear control designed for drilling or driving at LO (mark is 1) or HI (mark is 2) speeds. A slide switch is located on top of the drill to select either LO or HI speed. When using the drill in the LO speed range, the speed will decrease and the drill will have greater power and torque. When using the drill in the HI speed range, the speed will increase and the drill will have less power and torque.

Gear I

Low speed range: for screwdriving or working with large drilling diameter

Gear II

High speed range: for working with small drilling diameter

 **WARNING: To prevent gear damage, always allow the chuck to come to a complete stop before changing the direction of rotation or the two-speed gear control.**

6. CHUCK ADJUSTMENT (See Fig. 6)

To open the chuck jaws rotate the front section of the chuck. Insert the drill bit between the chuck jaws and rotate the front section in the opposite direction. Ensure the drill bit is in the center of the chuck jaws. Finally, firmly rotate the front chuck section in the opposite directions. Your drill bit is now clamped in the chuck.

7. TORQUE ADJUSTMENT (See Fig. 7)

(Screw driving force of your drill driver)

The torque is adjusted by rotating the torque adjustment ring. The torque is greater when the torque adjustment ring is set on a higher setting. The torque is less when the torque adjustment ring is set on a lower setting.

Make the setting as follows:

1 - 4 for driving small screws

5 - 9 for driving screws into soft material

10 - 14 for driving screws into soft and hard material

15 - 20 for driving screws into hard wood

21 for driving larger screws

 for heavy drilling

 for drilling in masonry and concrete

8. AUTOMATIC SPINDLE LOCK (See Fig. 8)

The automatic spindle lock allows you to use it as a regular screwdriver. You can give an extra twist to firmly tighten a screw, loosen a very tight screw or continue working when the battery energy has expired. For manual screwdriver purposes, the chuck is automatically locked when the tool is off.

9. USING THE SIGHT LIGHT

To turn on the light simply press the on/off switch. When you release the on/off switch, the light will be off.

LED lighting increases visibility-great for dark or enclosed area. LED is also a battery capacity indicator. It will flash when power gets low.



Fig. 6



Fig. 7

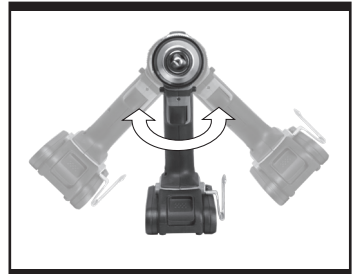

Fig. 8

10. DRILLING

When drilling into a hard smooth surface, use a center punch to mark the desired hole location. This will prevent the drill bit from slipping off center as the hole is started. Hold the tool firmly and place the tip of the bit at the point to be drilled. Depress the switch trigger to start the tool. Move the drill bit into the workpiece, applying only enough pressure to keep the bit cutting. Do not force or apply side pressure to elongate a hole.

If you want to activate the drill function (For drilling metal wood or plastic), turn the torque adjustment ring on the drill position. If you want to activate the impact function(For masonry or concrete), turn the torque adjustment ring on the hammer position.



TUNGSTEN carbide drill bits should always be used for concrete and masonry. When drilling in metal, only use HSS drill bits in good condition. Always use a magnetic bit holder (not included) when using short screwdriver bits. When screw-driving, apply a small quantity of liquid soap or similar to the screw threads to ease insertion.

11. DISPOSAL OF AN EXHAUSTED BATTERY PACK



To preserve natural resources, please recycle or dispose of the battery pack properly. This Li battery pack contains Lithium batteries.

Consult your local waste authority for information regarding available recycling and/or disposal options. Discharge your battery pack by operating your drill, then remove the battery pack from the drill housing and cover the battery pack connections with heavy-duty adhesive tape to prevent short circuit and energy discharge. Do not attempt to open or remove any of the components.

12. OVERLOAD PROTECTION

When overloaded, the motor comes to a stop. Relieve the load on the machine immediately and allow cooling for approx. 30 seconds at the highest no-load speed.

13. TEMPERATURE DEPENDENT OVERLOAD PROTECTION

When using as intended for the power tool cannot

be subject to overload. When the load is too high or the allowable battery temperature of 75 °C is exceeded, the electronic control switches off the power tool until the temperature is in the optimum temperature range again.

14. PROTECTION AGAINST DEEP DISCHARGING

The Li-ion battery is protected against deep discharging by the “Discharging Protection System”. When the battery is empty, the machine is switched off by means of a protective circuit: The inserted tool no longer rotates.

PROBLEM SOLUTION

1. WHY DOES THE DRILL NOT TURN ON WHEN YOU PRESS THE SWITCH?

The forward/reverse rotation control, which is on top of the trigger, is positioned in the lock function. Unlock the forward/reverse rotation control by putting it into the required rotation position. Push the trigger and the drill will start to rotate.

2. THE DRILL STOPS BEFORE THE SCREW IS COMPLETELY TIGHTENED. WHY?

Verify the torque position of the torque adjusting ring, you can find the torque-adjusting ring between the chuck and the drill body. Position 1 is the lowest torque (screw driving force) and position 21 is the highest torque (screw driving force). Position  is for drill operation. Regulate the torque adjusting ring to a higher position to reach the best result.

3. REASONS FOR DIFFERENT BATTERY PACK WORKING TIMES

Charging time problems, as above, and having not used a battery pack for a prolonged time will reduce the battery pack working time. This can be corrected after several charge and discharge operations by charging & working with your drill. Heavy working conditions such as large screws into hard wood will use up the battery pack energy faster than lighter working conditions. Do not re-charge your battery pack below 0°C and above 45°C as this will affect performance.

MAINTENANCE

Your tool requires no additional lubrication or maintenance.

There are no user serviceable parts in your power tool. Never use water or chemical cleaners to clean your power tool. Wipe clean with a dry cloth. Always store your power tool in a dry place. Keep the motor ventilation slots clean. Keep all working controls free of dust. Occasionally you may see sparks through the ventilation slots. This is normal and will not damage your power tool.

ENVIRONMENTAL PROTECTION



Waste electrical products should not be disposed of with household waste. Please  recycle where facilities exist. Check with your Local Authority or retailer for recycling advice. For further information visit www.recycle-more.co.uk.

PLUG REPLACEMENT (UK & IRELAND ONLY)

If you need to replace the fitted plug then follow the instructions below.

IMPORTANT

The wires in the mains lead are coloured in accordance with the following code:

BLUE = NEUTRAL

Brown = Live

As the colours of the wires in the mains lead of this appliance may not correspond with the coloured markings identifying the terminals in your plug, proceed as follows. The wire which is coloured blue must be connected to the terminal which is marked with N. The wire which is coloured brown must be connected to the terminal which is marked with L.



Warning:

Never connect live or neutral wires to the earth terminal of the plug. **Only fit an approved 5AMP BS1363/A plug and the correct rated fuse.**

Note: If a moulded plug is fitted and has to be removed take great care in disposing of the plug and severed cable, it must be destroyed to prevent engaging into a socket.

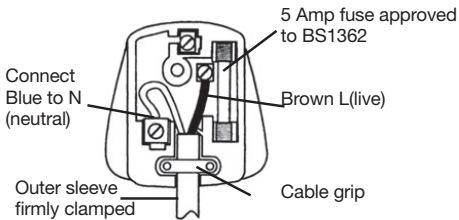

Erbauer®

DECLARATION OF CONFORMITY

We, Importer
Erbauer (UK) Ltd BA22 8RT

Declare that the product
Description: **18V COMBI DRILL**
Model: **ERI603COM**

Complies with the following directives,
EC Machinery Directive **2006/42/EC**
EC Low Voltage Directive **2006/95/EC**
EC Electromagnetic Compatibility Directive **2004/108/EC**
Restrictions of the Use of Certain Hazardous Substances in Electrical and Electronic Equipment **2011/65/EU**
Waste Electrical and Electronic Equipment (WEEE) **2012/19/EU**

Standards and technical specifications referred to:

EN 55014-1
EN 55014-2
EN 60745-1
EN 60745-2-1
EN 60745-2-2
EN 60335-1
EN 60335-2-29
EN 61000-3-2
EN 61000-3-3
EN 62233

Authorised Signatory and technical file holder

Date: 08/18/2014

Signature: P. C. Harries

Name / title: Peter Harries / Quality Manager
Erbauer (UK) Ltd. Trade House, Mead Avenue, BA22 8RT



Erbauer®