

## Original Instruction Manual

# BDS150 6" x 4" Belt & Disc Sander

Version 3.0  
January 2013



To register this product please visit  
[www.recordpower.info](http://www.recordpower.info)

It is important to register your product as soon as possible in order to receive efficient after sales support and be entitled to the full **5 year guarantee**. Your statutory rights are not affected. Please see back cover for contact details.



Always wear safety glasses when using woodworking equipment.



Always read the instructions provided before using woodworking equipment.



### Important

For your safety read instructions carefully before assembling or using this product. Save this manual for future reference.

# Contents

- 1 Explanation of Symbols
  - 2 General Health & Safety Guidance
  - 3 Additional Health & Safety for Belt & Disc Sanders
  - 4 Record Power Guarantee
  - 5 Machine Specification
  - 6 Assembly Instructions
  - 7 Operation
  - 8 Maintenance
  - 9 Dust Extraction
  - 10 Troubleshooting
  - 11 Electrical Connection & Wiring Diagram
  - 12 Parts Diagram
  - 13 Parts List
- EU Declaration of Conformity

# 1. Explanation of Symbols

THE SYMBOLS AND THEIR MEANINGS SHOWN BELOW MAY BE USED THROUGHOUT THIS MANUAL. PLEASE ENSURE THAT YOU TAKE THE APPROPRIATE ACTION WHEREVER THE WARNINGS ARE USED.

## Mandatory Instructions



Read and fully understand the instruction manual before attempting to use the machine.



Indicates an instruction that requires particular attention



Wear protective eyewear



Use respiratory protective equipment



Use hearing protection



Use suitable protective footwear



Use protective work gloves

## Warning



Indicates a risk of severe personal injury or damage to the machine



Indicates a risk of severe personal injury from electrical shock



Risk of personal injury from lifting of heavy items



Indicates a risk of severe personal injury from airborne objects



Risk of fire

# 2. General Health & Safety Guidance

Ensure that you carefully read and fully understand the instructions in this manual before assembly, installation and use of this product. Keep these instructions in a safe place for future reference.

**WARNING:** for your own safety, do not attempt to operate this machine until it is completely assembled and installed according to these instructions.

**WARNING:** When using any machine, basic safety precautions should always be followed to reduce the risk of fire, electric shock and personal injury.

## Safe Operation

### 1. Use Personal Protective Equipment (PPE)

- The operation of any machine can result in foreign objects being thrown into your eyes, which can result in severe eye damage. Protective eyewear or other suitable eye protection or face shield should be used at all times. Everyday spectacles only have impact resistant lenses. They are not protective eyewear and do not give additional lateral protection.
- Use respiratory protective equipment (dust mask etc.) if the machining operation creates dust. Exposure to high levels of dust created by machining hardwoods, softwoods and man made composite boards can result in serious health problems. Some imported hardwoods give off highly irritating dust, which can cause a burning sensation. The use of respiratory protective equipment should not be seen as an alternative to controlling the risk of exposure at source by using adequate dust extraction equipment.
- The use of ear plugs or ear defenders is recommended when the machine is in use, particularly if the noise level exceeds 85 dB.
- Wear suitable protective gloves when handling cutting tools or blades. Gloves should NOT be worn when using the machine as they can be caught in moving parts of the machine.
- Non-slip safety footwear is recommended when using the machine and handling large work pieces.

### 2. Dress appropriately

- Do not wear loose clothing, neckties or jewellery; they can be caught in moving parts of the machine.
- Roll up long sleeves above the elbow.
- Wear protective hair covering to contain long hair.

### 3. Safety warnings

- Find and read any warning labels on the machine.
- It is important that any labels bearing health and safety warnings are not removed, defaced or covered. Replacement labels can be obtained by contacting our Customer Service Department.

### 4. Familiarise yourself with the machine

- If you are not thoroughly familiar with the operation of this machine, obtain advice from your supervisor, instructor, or other qualified person or contact your retailer for information on training courses. Do not use this machine until adequate training has been undertaken.

### 5. Take care when moving or positioning the machine

- Some machines can be very heavy. Ensure the floor of the area in which the machine is to be used is capable of supporting the machine.
- The machine and its various components can be heavy. Always adopt a safe lifting technique and seek assistance when lifting heavy components. In some cases it may be necessary to use mechanical handling equipment to position the machine within the work area.
- Some machines have optional wheel kits available to allow them to be manoeuvred around the workshop as required. Care should be taken to install these according to the instructions provided.
- Due to the nature of the design of some machines the centre of gravity will be high making them unstable when moved. Extreme care should be taken when moving any machine.
- If transportation of the machine is required then all precautions relating to the installation and handling of the machine apply. In addition, ensure that any vehicles or manual handling equipment used for transportation is of adequate specification.

### 6. The machine should be level and stable at all times

- When using a leg stand or cabinet base that is designed to be fitted to the machine, always ensure that it is securely fastened to the machine using the fixings provided.
- If the machine is suitable to be used on a workbench, ensure that the workbench is well constructed and capable of withstanding the weight of the machine. The machine should always be securely fastened to the workbench with appropriate fixings.
- Where possible, floor standing machines should always be secured to the floor with fixings appropriate to the structure of the floor.

## 2. General Health & Safety Guidance - cont.

- The floor surface should be sound and level. All of the feet of the machine should make contact with the floor surface. If they do not, either re-locate the machine to a more suitable position or use packing shims between the feet and the floor surface to ensure the machine is stable.

### 7. Remove adjusting keys and wrenches

- Ensure that all adjusting wrenches and keys are removed before switching the machine 'ON'. There is a risk of severe personal injury or damage to the machine from airborne objects.

### 8. Before switching the machine 'ON'

- Clear the machine table of all objects (tools, scrap pieces etc.)
- Make sure there is no debris between the work piece and the table / work support.
- Ensure that the work piece is not pressed against, or touching the saw blade or cutting tool.
- Check all clamps, work holding devices and fences to ensure that they are secure and cannot move during machining operations.
- Plan the way that you will hold and feed the work piece for the entire machining operation.

### 9. Whilst machining

- Before starting work, watch the machine while it runs. If it makes an unfamiliar noise or vibrates excessively, switch the machine 'OFF' immediately and disconnect it from the power supply. Do not restart until finding and correcting the source of the problem.

### 10. Keep the work area clear

- Working clearances can be thought of as the distances between machines and obstacles that allow safe operation of every machine without limitation. Consider existing and anticipated machine needs, size of material to be processed through each machine and space for auxiliary stands and/or work tables. Also consider the relative position of each machine to one another for efficient material handling. Be sure to allow yourself sufficient room to safely operate your machines in any foreseeable operation.
- Cluttered work areas and benches create the risk of accidents. Keep benches clear and tidy away tools that are not in use.
- Ensure that the floor area is kept clean and clear of any dust and debris that may create trip or slip hazards.

### 11. Consider the work area environment

- Do not expose the machine to rain or damp conditions.
- Keep the work area well lit and ensure that there is artificial lighting available when there is insufficient natural light to effectively light the work area. Lighting should be bright enough to eliminate shadow and prevent eye strain.
- Do not use the machine in explosive environments eg. in the presence of flammable liquids, gases or dust.
- The presence of high levels of dust created by machining wood can present a risk of fire or explosion. Always use dust extraction equipment to minimise the risk.

### 12. Keep other persons away (and pets)

- The machine is designed to be used by one person only.
- Do not let persons, especially children, touch the machine or extension cable (if used) and keep visitors away from the work area.
- Never leave the machine running unattended. Turn the power supply off and do not leave the machine unattended until it comes to a complete stop.
- If the work area is to be left unattended, all machinery should be switched 'OFF' and isolated from the mains power supply.

### 13. Store machines safely when not in use

- When not in use, machines should be stored in a dry place, out of reach of children. Do not allow persons unfamiliar with these instructions or with the machine to operate it.

### 14. Do not overreach

- Choose a working position that allows your body to remain balanced and feed the work piece in to the machine without overreaching.

- Keep proper footing and balance at all times.

### 15. Electrical supply

- Electrical circuits should be dedicated to each machine or large enough to handle combined motor amp loads. Power outlets should be located near each machine so that power or extension cables are not obstructing high-traffic areas. Observe local electrical guidelines for proper installation of new lighting, power outlets, or circuits.
- The machine must be connected to an earthed power supply.
- The power supply must be equipped with a circuit breaker that provides short circuit, overload and earth leakage protection.
- The voltage of the machine must correspond to the voltage of the mains power supply.
- The mains plug fitted to the machine should always match the power outlet. Do not modify the plug in any way. If a replacement plug is required it should be fitted by a competent person and of the correct type and rating for the machine.
- If you are unsure about any electrical connections always consult a qualified electrician.

### 16. Avoid unintentional starting of the machine

- Most machines are fitted with a no-volt release (NVR) switch to prevent unintentional starting. If in doubt always ensure the machine switch is in the 'OFF' position before connecting it to the power supply. This means the machine will not automatically start up after a power cut or switching on of the power supply, unless you first reset the start switch.

### 17. Outdoor use

- Your machine should not be used outdoors.

### 18. Extension cables

- Whenever possible, the use of extension cables is not recommended. If the use of an extension cable is unavoidable, then it should have a minimum core cross section of 2.5 mm<sup>2</sup> and limited to a maximum length of 3 metres.
- Extension cables should be routed away from the direct working area to prevent a trip hazard.

### 19. Guard against electric shock

- Avoid body contact with earthed or grounded surfaces such as pipes and radiators. There is an increased risk of electric shock if your body is earthed or grounded.

### 20. Always work within the machine's intended capacities

- Operator safety and machine performance are seriously adversely affected if attempts to make the machine perform beyond its limits are made.

### 21. Do not abuse the power cable

- Never pull the power cable to disconnect it from the power socket. Always use the plug.
- Keep the power cable away from heat, oil and sharp edges.
- Do not use the power cable for carrying or moving the machine.

### 22. Secure the work piece

- Ensure that the work piece is securely held before starting to machine it.
- When working within 300 mm of the machining area, always use a push stick to feed the work piece in to the blade or cutting tool. The push stick should have a minimum length of 400 mm. If the push stick becomes damaged, replace it immediately.
- Use extra supports (roller support stands etc.) for any work pieces large enough to tip when not held down to the table top.
- Do not use another person as a substitute for a table extension, or as additional support for a work piece that is longer or wider than the basic table, or to help feed, support, or pull the work piece.
- Do not attempt to machine more than one work piece at a time.
- When feeding the work piece towards the blade or cutting tool never position your hands in direct line of the cutting path. Avoid awkward operations and hand positions where a sudden slip could cause your hand or fingers to move into the machining area.

### 23. Stay alert

## 2. General Health & Safety Guidance - cont.

- Safety is a combination of operator common sense and alertness at all times when the machine is being used.
- Use all machines with extreme care and do not use the machine when you are tired or under the influence of drugs, alcohol or medication.

### 24. Use the correct tool for the job

- Do not use the machine for any purpose other than which it was designed.
- When selecting replacement cutting tools and blades, always ensure that they are designed to cut the material that you intend to use them for. If in any doubt seek further advice from the manufacturer.

### 25. Connect dust extraction equipment

- Always use dust extraction equipment. The dust extractor should be of suitable size and capacity for the machine that it is connected to and have a filtration level appropriate to the type of waste being collected. Refer to the relevant section of the manual for details of the specific dust extraction requirements for this machine.
- The dust extractor should be switched 'ON' before starting the machine that it is connected to. The dust extractor should be left running for 30 seconds after the last machining operation is complete in order to clear any residual waste from the machine.

### 26. Ensure that the machine is correctly guarded

- Never use the machine if any of the standard safety guards and equipment are removed or damaged.
- Some machines incorporate safety interlocks to prevent the machine from being used without the guards in place. Never attempt to bypass or modify the interlocks to allow the machine to be used without the guards in place.

### 27. Maintain your machine with care

- This manual gives clear instructions on installation, set up and operation of the machine and also details any routine and preventative maintenance that should be performed periodically by the user.
- Remember always to switch off and unplug the machine from the power supply before carrying out any setting up or maintenance operations.
- Follow any instructions for the maintenance of accessories and consumables.
- Do not use compressed air to clean the machine. Always use a brush to dislodge dust in places that are awkward to reach and a dust extractor to collect the waste.
- Inspect electric cables periodically and, if damaged, have them replaced

by an authorised service facility or qualified electrician.

- Inspect extension cables (if used) periodically and replace if damaged.

### 28. Keep cutting tools sharp and clean

- Correctly maintained cutting tools are easier to control and less likely to bind.
- Cutting tools and blades can become hot during use. Take extreme care when handling them and always allow them to cool before changing, adjusting or sharpening them.

### 29. Disconnect the machine from the power supply

- When not in use, before servicing, changing blades etc. always disconnect the machine from the power supply.

### 30. Check for damaged parts

- Before each use of the machine, it should be carefully checked to determine that it will operate properly and perform its intended function.
- Check for alignment of moving parts, binding of moving parts, breakage of parts and any other conditions that may affect the operation of the machine.
- A guard or other part that is damaged should be properly repaired or replaced by a qualified person unless otherwise indicated in this instruction manual.
- Do not use the machine if the switch does not turn the machine 'ON' and 'OFF'.
- Have defective switches replaced by a qualified person.

### 31. Warning!

- The use of any accessory or attachment, other than those recommended in this instruction manual, or recommended by our Company may present a risk of personal injury or damage to the machine and invalidation of the warranty.

### 32. Have your machine repaired by a qualified person

- This machine complies with the relevant safety rules and standards appropriate to its type when used in accordance with these instructions and with all of the standard safety guards and equipment in place. Only qualified persons using original spare parts should carry out repairs. Failure to do this may result in considerable danger to the user and invalidation of warranty.

### 33. Caution! Motor may become hot during use

- It is normal for motors on some machines to become hot to the touch during use. Avoid touching the motor directly when in use.

## 3. Additional Health & Safety for Belt & Disc Sanders

### Safe Operation

#### 1. Familiarise yourself with the machine

- Machining operations using belt or disc sanders have a history of serious accidents. Most accidents with sanders are caused by the work piece being thrown from the sanding surface or by loose clothing or fingers being caught between the moving parts of the machine.
- The machine is designed for sanding wood and composite board (plywood, MDF etc.). It should not be used for sanding any other materials.

#### 2. Before switching the machine 'ON':

- Ensure that the table / work support is secure and that any fixings which allow adjustment are fully tightened.
- Check the condition of the sanding disc / belt for damage or fraying. Defective discs and belts should be replaced immediately.
- Make sure there are no nails or foreign objects in the part of the work piece to be sanded.
- Plan your work to avoid throwbacks – the work piece can catch on the moving sanding surface and may be torn from the hand.

#### 3. Whilst machining:

- Always apply the work piece to the table / work support before it makes contact with the sanding surface.
- Use extra caution when working with large, very small or irregularly shaped work pieces.

- When sanding irregularly shaped work pieces, plan your work support so it will not slip and be pulled from your hands.
- Never use the machine to finish pieces too small to hold by hand.
- Do not apply excessive force to the work piece. Press the work piece against the sanding surface only hard enough to let it sand without slowing the machine or binding.
- Keep fingers away from the area between the table / work support and sanding surface.
- When using a disc sander, always press the work piece against the side of the disc that is moving down towards the table. Sanding against the side coming up from under the table could damage the work by making it "chatter", or tear the work from the hands and throw it.
- Keep your face and body to one side, out of line of a possible throwback.

4. This machine falls under the scope of the 'Health & Safety at Work etc. Act 1974', and the 'Provision & Use of Work Equipment Regulations 1998'. In addition the elimination or control of risks from wood dust is included in the above regulations and the 'Control of Substances Hazardous to Health (COSHH) Regulations 2002'. We recommend that you study and follow these regulations.

Further guidance is available from The Health & Safety Executive and their website [www.hse.gov.uk](http://www.hse.gov.uk).



# 4. Record Power Guarantee

“**Products**” means the Products sold by Record Power subject to these terms and conditions;

“**Record Power**” is Record Power Limited, whose company registration number is 4804158 and registered office address is Centenary House, 11 Midland Way, Barlborough Links, Chesterfield, Derbyshire S43 4XA and sells through a network of Authorised Dealers;

“**Authorised Distributor**” is the nominated importer for your region who will generally sell through a network of Authorised Dealers. Details of Authorised Distributors for specific countries can be found in the Product manual or at [www.recordpower.info](http://www.recordpower.info);

“**Authorised Dealer**” is a retailer or business authorised to sell Record Power Products to end users.

## 1 Guarantee

- 1.1 Record Power guarantees that for a period of 5 years from the date of purchase the components of qualifying Products (see clauses 1.2.1 to 1.2.9) will be free from defects caused by faulty construction or manufacture.
- 1.2 During this period Record Power, its Authorised Distributor or Authorised Dealer will repair or replace free of charge any parts which are proved to be faulty in accordance with paragraphs 1.1 above provided that:
  - 1.2.1 you follow the claims procedure set out in clause 2 below;
  - 1.2.2 Record Power, our Authorised Distributor or Authorised Dealer are given a reasonable opportunity after receiving notice of the claim to examine the Product;
  - 1.2.3 if asked to do so by Record Power, its Authorised Distributor or Authorised Dealer, you return the Product, at your own cost, to Record Power's premises or other approved premises such as those of the Authorised Distributor or supplying Authorised Dealer, for the examination to take place;
  - 1.2.4 the fault in question is not caused by industrial use, accidental damage, fair wear and tear, wilful damage, neglect, incorrect electrical connection, abnormal working conditions, failure to follow our instructions, misuse, or alteration or repair of the Product without our approval;
  - 1.2.5 the Product has been used in a domestic environment only;
  - 1.2.6 the fault does not relate to consumable Products such as blades, bearings, drive belts or other wearing parts which can reasonably be expected to wear at different rates depending on usage (for full details contact Record Power or your local Authorised Distributor);
  - 1.2.7 the Product has not been used for hire purposes, by you or by a previous owner;
  - 1.2.8 the Product has been purchased by you as the guarantee is not transferable from a private sale.
  - 1.2.9 where the Product has been purchased from a retailer, the 5 year guarantee is transferable and begins on the date of the first purchase of the Product and in the event of a claim under this guarantee proof of the original purchase date will be required to validate the warranty period.

## 2 Claims Procedure

- 2.1 In the first instance please contact the Authorised Dealer who supplied the Product to you. In our experience many initial problems with machines that are thought to be due to faulty parts are actually solved by correct setting up or adjustment of the machines. A good Authorised Dealer should be able to resolve the majority of these issues much more quickly than processing a claim under the guarantee.
- 2.2 Any damage to the Product resulting in a potential claim under the guarantee must be reported to the Authorised Dealer from which it was purchased within 48 hours of receipt.
- 2.3 If the Authorised Dealer who supplied the Product to you has been unable to satisfy your query, any claim made under this Guarantee should be made directly to Record Power or its Authorised Distributor (for details of the Authorised Distributor in your country please see your Product manual or check [www.recordpower.info](http://www.recordpower.info) for details). The claim itself should be made in a letter setting out the date and place of purchase, and giving a brief explanation of the problem which has led to the claim. This letter should then be sent with proof of the purchase date (preferably a receipt) to Record Power or its Authorised Distributor. If you include a phone number or email address this will help to speed up your claim.
- 2.4 Please note that it is essential that the letter of claim reaches Record Power or its Authorised Distributor on the last day of this Guarantee at the latest. Late claims will not be considered.

## 3 Limitation of Liability

- 3.1 We only supply Products for domestic and private use. You agree not to use the Product for any commercial, business or re-sale purposes and we have no liability to you for any loss of profit, loss of business, business interruption or loss of business opportunity.
- 3.2 This Guarantee does not confer any rights other than those expressly set out above and does not cover any claims for consequential loss or damage. This Guarantee is offered as an extra benefit and does not affect your statutory rights as a consumer.

## 4 Notice

This Guarantee applies to all Products purchased from an Authorised Dealer of Record Power within the United Kingdom of Great Britain and Northern Ireland. Terms of Guarantee may vary in other countries – please check with the Authorised Distributor in your country (details of the Authorised Distributor for your country can be found in the manual or at [www.recordpower.info](http://www.recordpower.info)).

# 5. Machine Specification

<b>Motor:</b>	230 V ~, 50 Hz, 400 W, 2850 rpm	<b>Mitre Slot:</b>	16 mm
<b>Belt Speed:</b>	490 m/min	<b>Sanding Pad:</b>	152 mm
<b>Disc Speed (min-1):</b>	2850 rpm	<b>Sanding Belt:</b>	101 mm x 914 mm
<b>Table Size:</b>	159 mm x 225 mm Tilt 45°	<b>Noise Emission:</b>	Sound power level < 85 dB(A) Sound pressure level < 85 dB(A)
<b>Weight:</b>	17 kg	<b>Full load current:</b>	1.9 A
<b>Power Switch:</b>	No-Volt Release Switch		

# 6. Assembly Instructions

## UNPACKING

When unpacking, check to make sure that the parts listed below are included.



**WARNING: To avoid injury, if any parts are missing, do not attempt to assemble the Belt and Disc Sander, do not plug in the power cord, do not turn the switch on until the missing parts are obtained and installed correctly.**

**Tools needed:** 6 mm wrench, Phillips screwdriver, standard screwdriver, try square or combination square and 6 mm Hex wrench.

Part No.	Description
1	Main machine
2	Table
3	150 mm sanding disc
4	Table support
5	Disc guard
6	Work support
7	Mitre fence
8	Extra table support bracket
9	Sanding bed table support
10	Angle scale
11	4 x m6 flat washers
12	4 x m6 bolts
13	4 x Phillips head screws
14	2 x self tapping screws
15	Table knob
16	4 x star washers
17	6 mm hex wrench

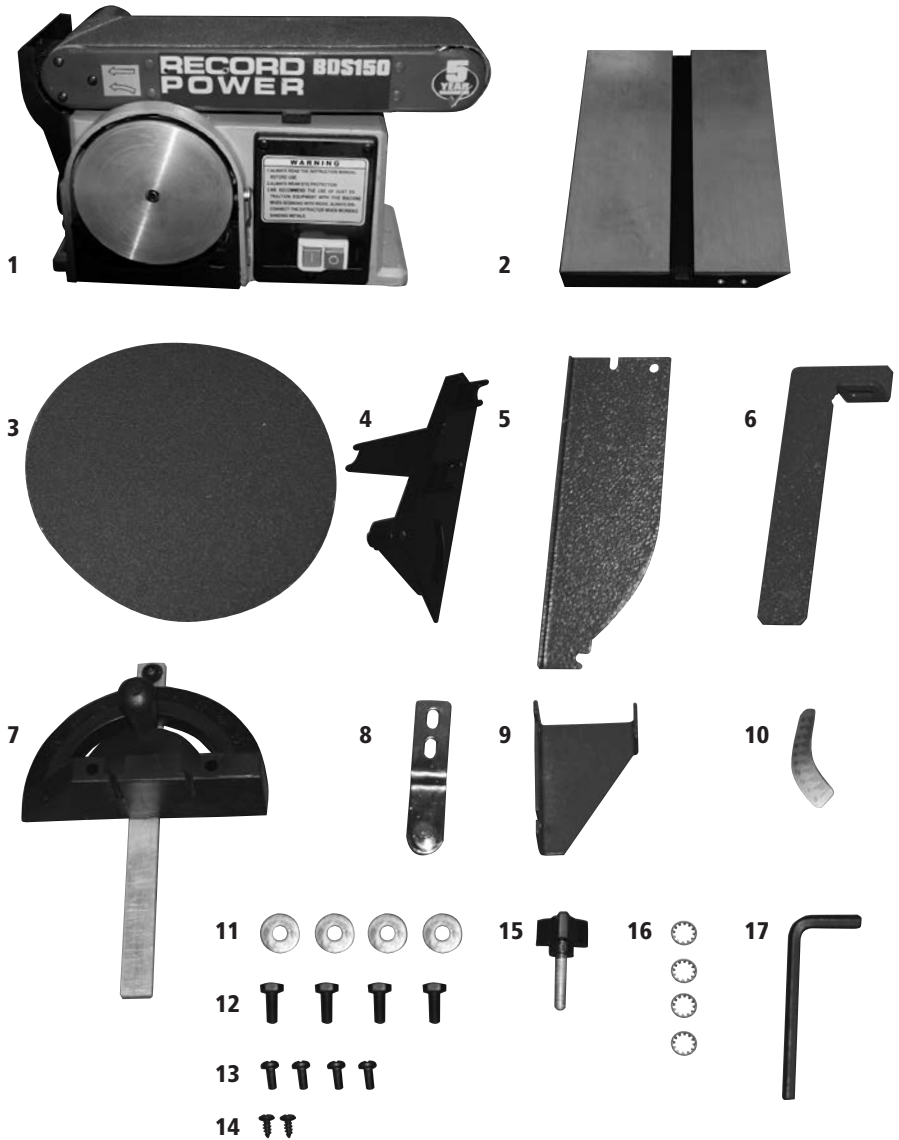

# 6. Assembly Instructions - cont.

## MOUNTING BELT AND DISC SANDER TO WORKBENCH

We recommend the belt and disc sander is fastened securely to a firm supporting surface such as a workbench. Follow the procedure set out below and refer to **Fig.1**.

1. Place sander in operational position on workbench.
  2. Place a pencil through the holes in the sander base and mark drill holes in workbench.
  3. Remove sander and drill two 10 mm diameter holes through the workbench.
  4. Align sander base over holes and secure using two 8 mm nuts and bolts.
- NOTE:** The hole marked (A) in Fig.1 should be a maximum of 70 mm from the front edge of the work bench.

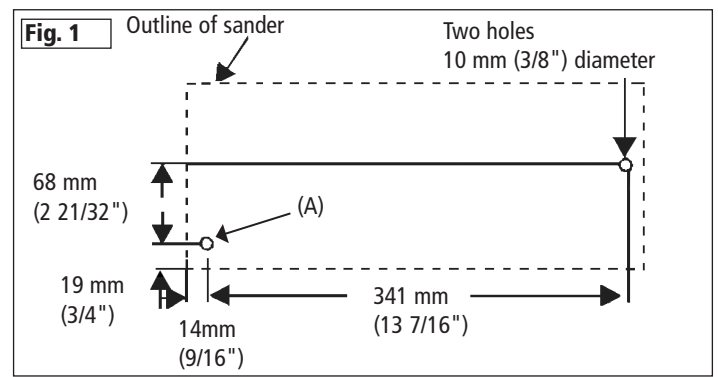

## MOUNTING SANDING DISC AND GUARD

1. Peel the backing from the sanding disc.
2. Align perimeter of sanding disc (A) over plate. When aligned, press sandpaper disc firmly onto plate. **Fig.2**.
3. Position disc guard (B) onto lower portion of plate so that the mounting holes align.
4. Using a Phillips screwdriver, fasten two pan head screws over disc guard.

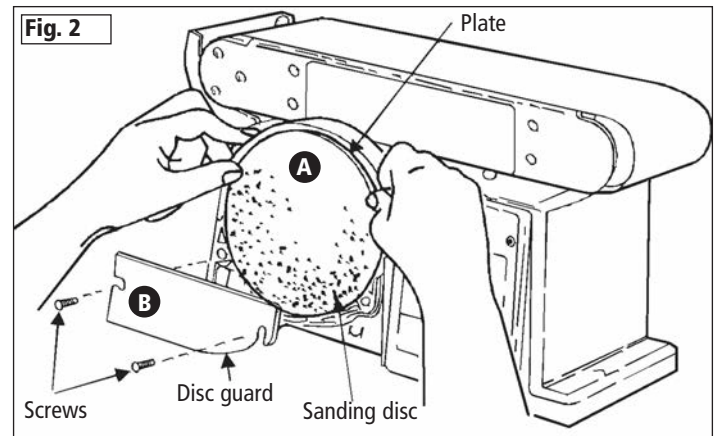

## INSTALLING WORK SUPPORT

1. Place work support over sanding belt as shown **Fig.3**.
2. Place the hex. screw through the lock washer and flat washer secure. Do not over tighten.

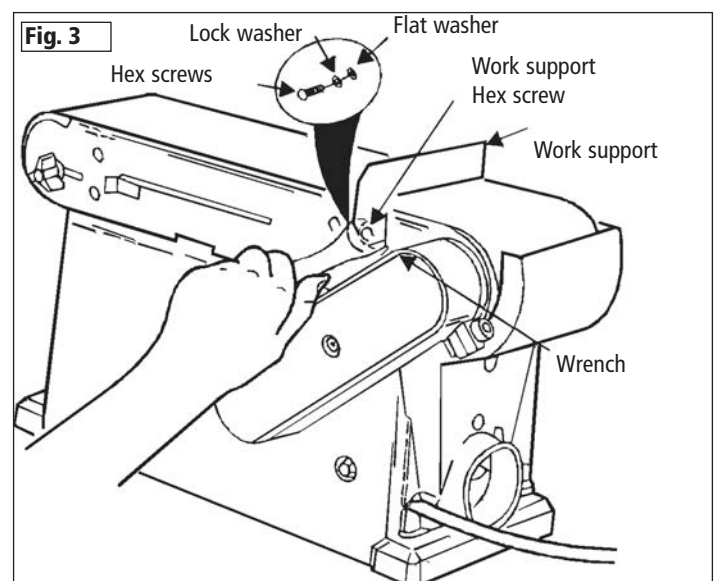



# 6. Assembly Instructions - cont.

## MOUNTING TABLE ASSEMBLY

1. Stand table on its side, aligning holes as shown in **Fig. 4**.
2. Fasten table support to table. Do not over tighten screws.
3. Position table support in corresponding holes on side of base as shown in **Fig. 5**.
4. Place washer on table knob shaft and insert through slot into threaded holes in base.
5. Loosen the three hex screws which hold the table to the table support and adjust table so that there is a maximum of 3 mm space between the sanding disc and the table **Fig. 6**, tighten screws.
6. Attach the right hand table support bracket to the table with the 2 self tapping screws, **Fig. 7**.

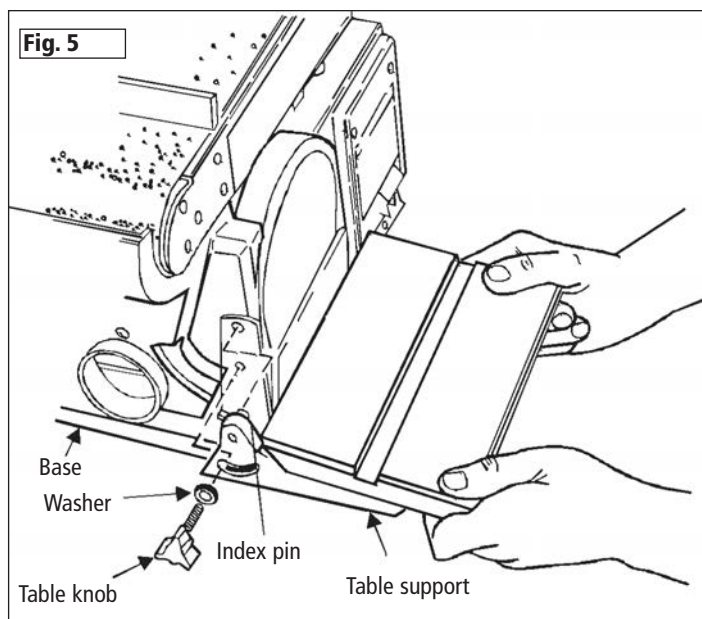
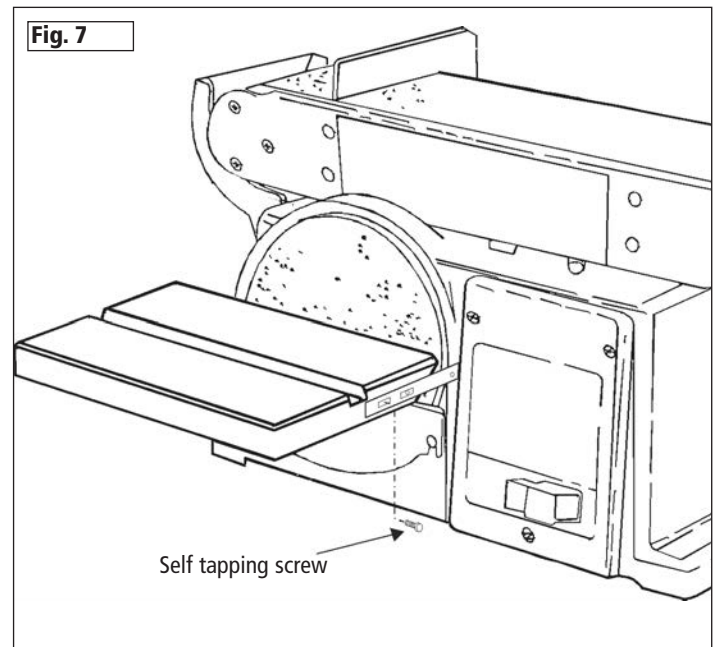
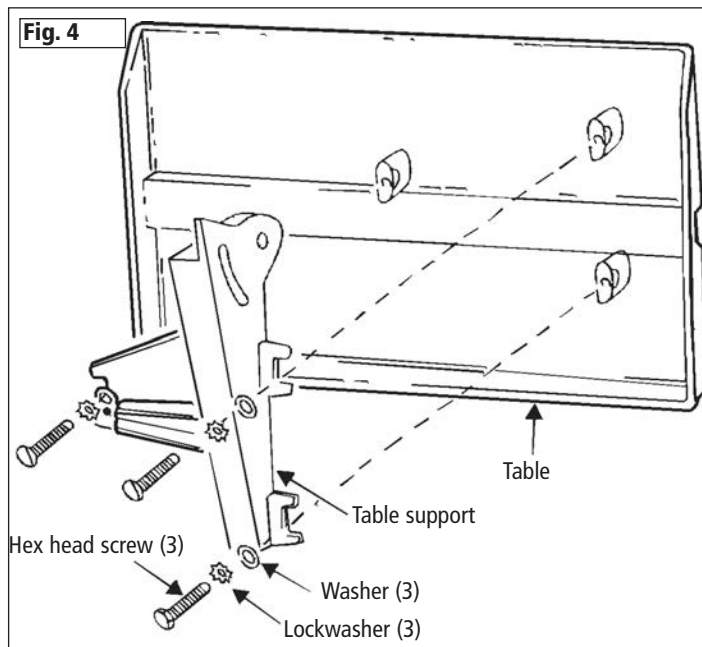
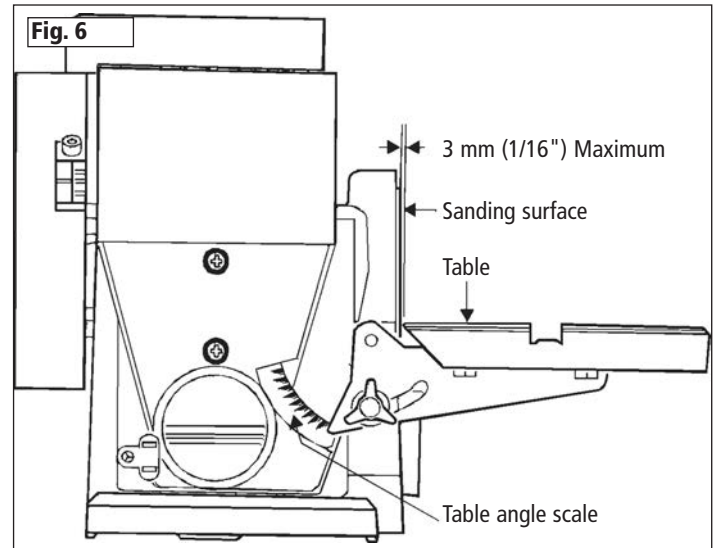

# 6. Assembly Instructions - cont.

## REMounting TABLE FOR VERTICAL SANDING

1. using a 6 mm wrench, remove the hex bolt from the work support and detached it from the sanding bed, **Fig. 3**.
2. Undo the locking bolt at the left of the sanding belt **Fig. 10**, and reposition the sanding bed as required.
3. Fit the sanding bed table support bracket to the side of the bed as shown in **Fig. 8**.
4. Fit the extra table support bracket to the sanding bed table support, **Fig. 8**.
5. Attach the table to the extra table support bracket using the 2 self tapping screws, **Fig. 10**.
6. Insert the table knob through the table support and screw into the side of the bed, **Fig. 9**.

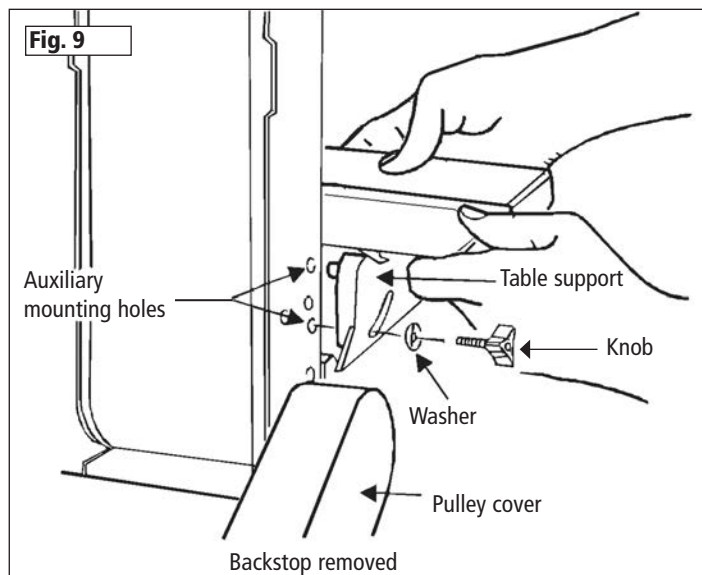
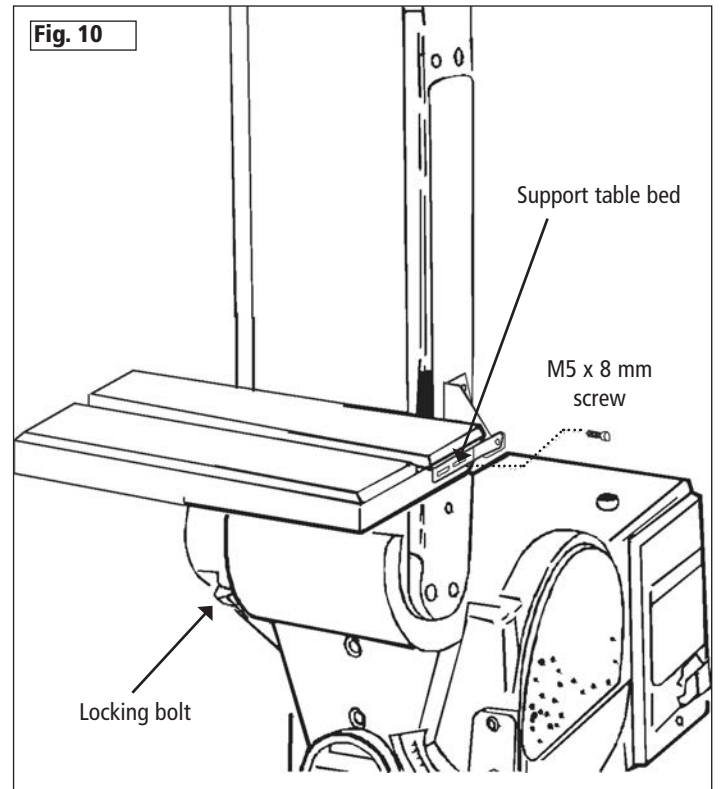
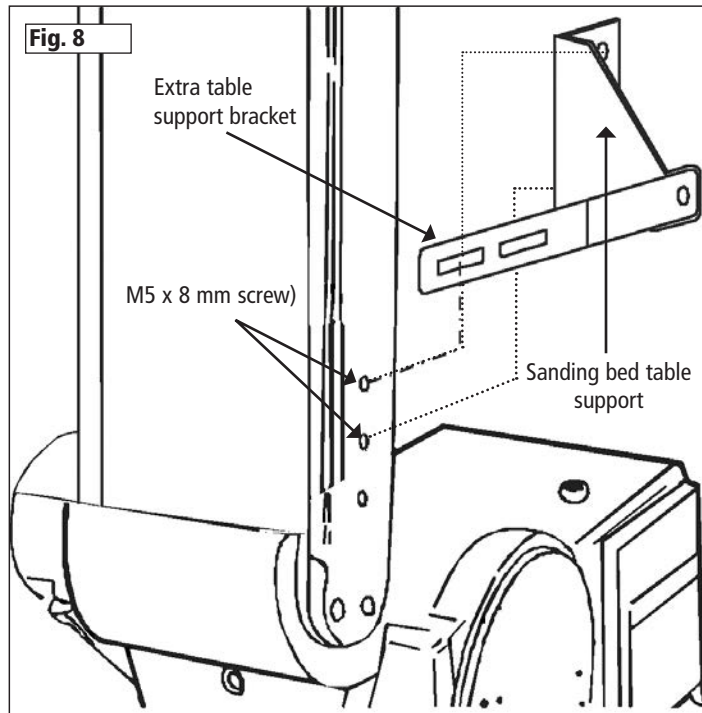

# 7. Operation



Before carrying out any maintenance or adjustment, ensure the machine is turned off and unplugged from power supply.

## LEVELLING THE TABLE ASSEMBLY

1. Place a combination square or try square on the table so that it also touches the sanding pad, **See Fig.11**.  
If the table is 90 degrees to the pad, the square is flush on the pad.
2. If the table is not 90 degrees to the with the pad, loosen the table lock knob (item 1) and tilt the table until the square is flush with the pad
3. Retighten the knob to secure the table.
4. Attach the angle scale to the '0' degrees mark on the dust guard.

## INSTALLING AND ADJUSTING THE SANDING BELT

1. Turn the machine off and disconnect power cord from the mains electricity supply.
2. Move tension lever to the right to release the sanding belt tension, **See Fig.12**.
3. Place the sanding belt over the drive and idler drums, making sure that the inside direction arrow points down, towards the drive drum as shown in **Fig.12**.
4. Centre belt on both drums.
5. Slide tension lever to the left to tighten belt tension.
6. Tighten locking bolt when bed is in desired working position.
7. Reconnect the power cord to the main electricity supply. Turn the no-volt release switch, ON then OFF, while viewing the belt movement. If the belt looks likely to slide off either drum, the belt tracking needs to be adjusted (described in the next step).
8. If the sanding belt moves towards the sanding pad when turned ON, turn the tracking knob clockwise 1/4 turn, and test again.
9. If the sanding belt moves away from the sanding pad when it was turned ON, turn the tracking knob counterclockwise 1/4 turn, and test again.

## IN THE EVENT OF A BLOCKAGE OR IF THE MACHINE STALLS

If the machine stalls due to the work piece or sanding belt becoming trapped, switch the machine off immediately by pressing the red button on the switch marked 'O'. Unplug the machine from the power supply. Locate and rectify the source of the blockage. If the sanding belt has become trapped, it may be necessary to cut the belt in order to remove it from the machine. Replace the belt as necessary and track it correctly by following the procedure set out above.

Check that the belt can be turned freely by hand before attempting to re-start the machine. Re-start the machine by pressing the green button on the switch marked 'I'.

## RE-STARTING AFTER A POWER FAILURE

The machine is fitted with a no volt release (NVR) switch to protect the user from automatic re-starting after a power failure.

In the event of a power failure, first locate and rectify the source of the failure. If the fault is within the power circuit of the workshop, there may be an underlying cause (circuit overload etc.) that should be investigated by a qualified electrician, before attempting to restore the power source. Once the power is restored, re-start the machine by pressing the green button marked 'I' on the switch.

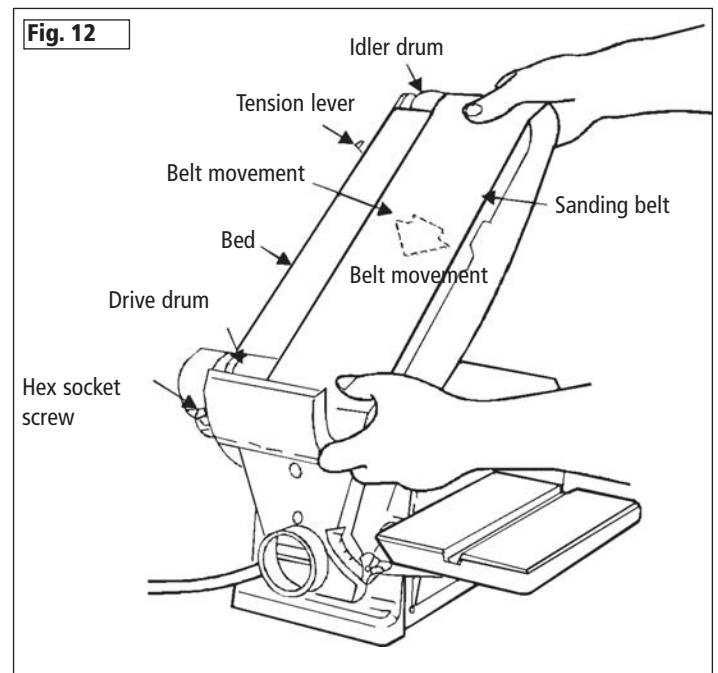
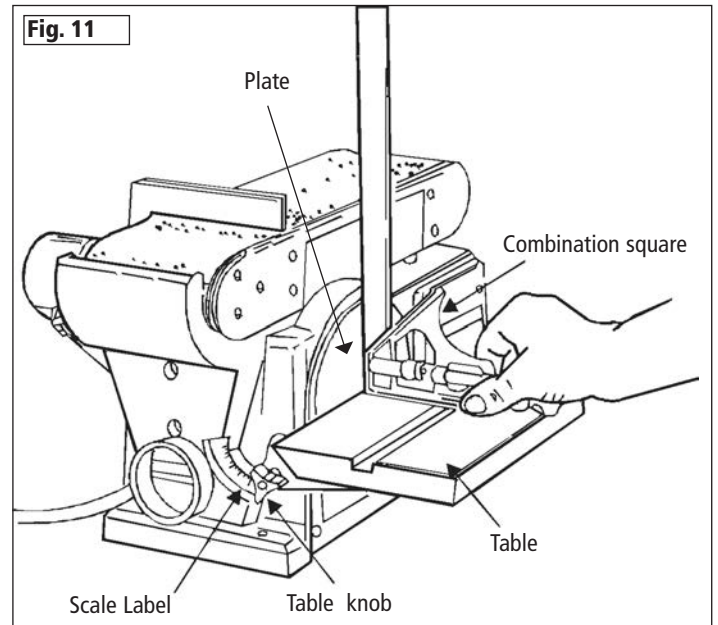

# 7. Operation - cont.

## SANDING METHODS

Surface sanding on belt

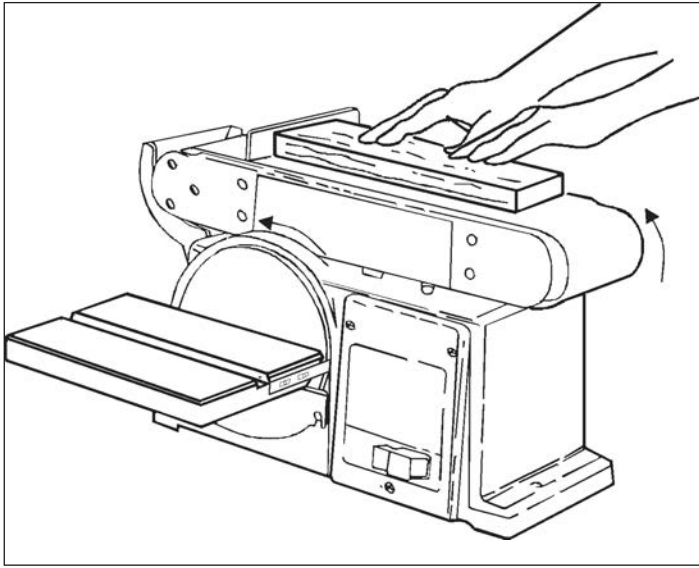

End sanding on belt

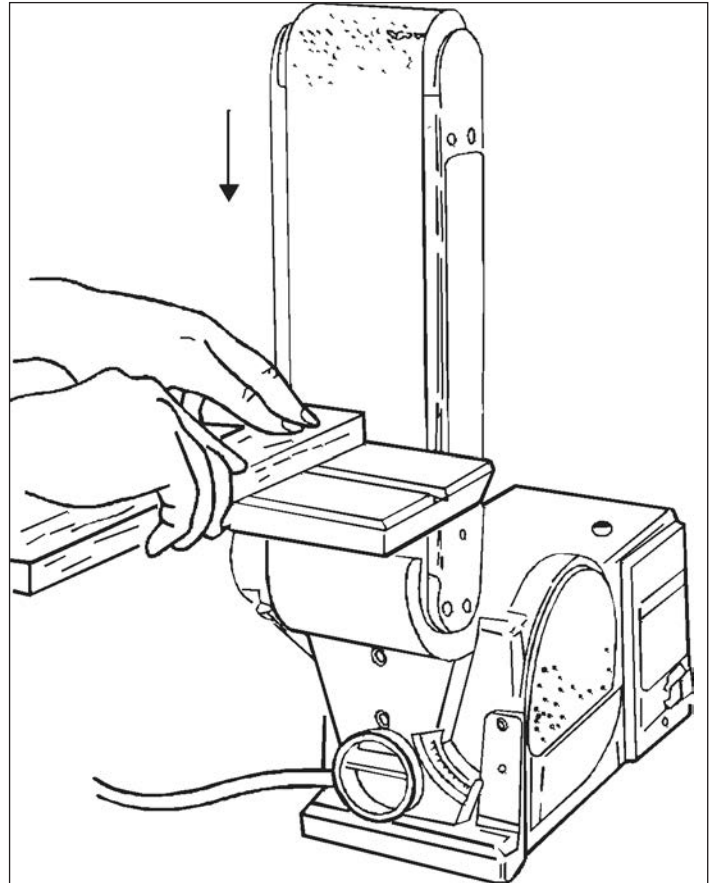

Shaping sanding using disc. When using disc the workpiece should make contact with left hand side of disc only, as shown.

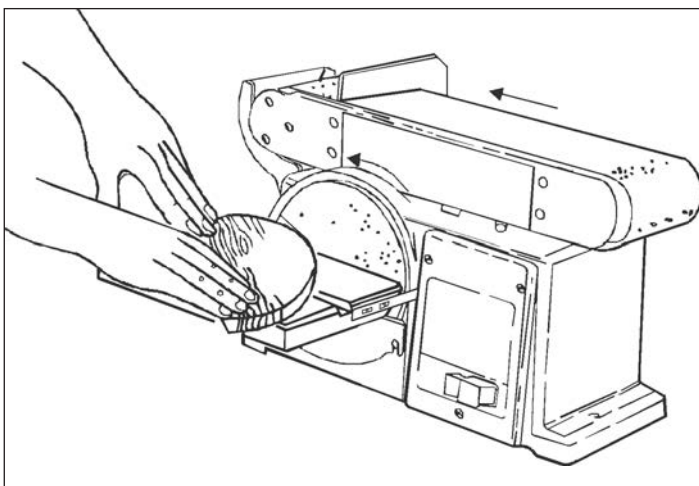

Sanding curves using idler drum

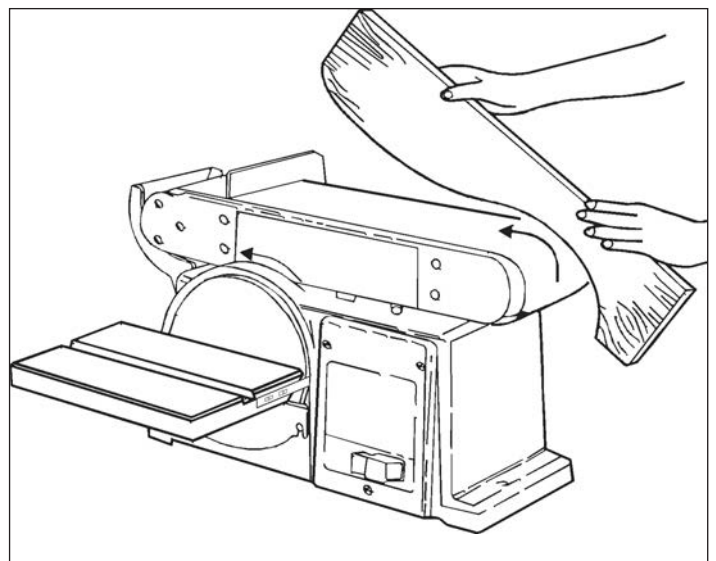



# 8. Maintenance



Before carrying out any maintenance or adjustment, ensure the machine is turned off and unplugged from power supply.

## DRIVE BELT REPLACEMENT

1. Using a Phillips screwdriver, remove the screw from belt cover, and remove cover **Fig.13**.
2. Loosen three screws to allow drive pulley to move enough to place drive belt around them **Fig.14**.
3. Place drive belt around motor pulley then drive pulley.
4. Tighten the three screws slightly.
5. Adjust tension of drive belt by placing a standard screwdriver in the adjusting hole by pushing up on the screwdriver to apply tension to the drive belt **Fig.15**.
6. Tighten the three screws again.
7. Squeeze the drive belt between two fingers in the centre of the belt. If the belt has been correctly tensioned there should be about 6 mm of movement.



**NOTE: Too much tension on the drive belt can over load motor and possibly cause damage. If the drive belt is too loose, it may fail prematurely.**

8. Replace belt cover.

## MACHINE CARE

1. Apply a light coat of silicone spray or wax paste to the worktable to make feeding stock easier.
- 2 Use a suitable dust extractor and brush to clear out dust and debris from sander and motor.

## OIL BEARING SLEEVES

Oil bearing sleeves after each 10 hours of use with 30w oil.

- 1 Release belt tension by sliding the tension lever to the right **Fig.16**.
2. Move the sanding belt slightly to the left or right of the idler drum to expose the oval shaped oiling hole.
3. Apply only two or three drops of oil in the left and right oiling holes.
4. Adjust belt tracking as previously described.

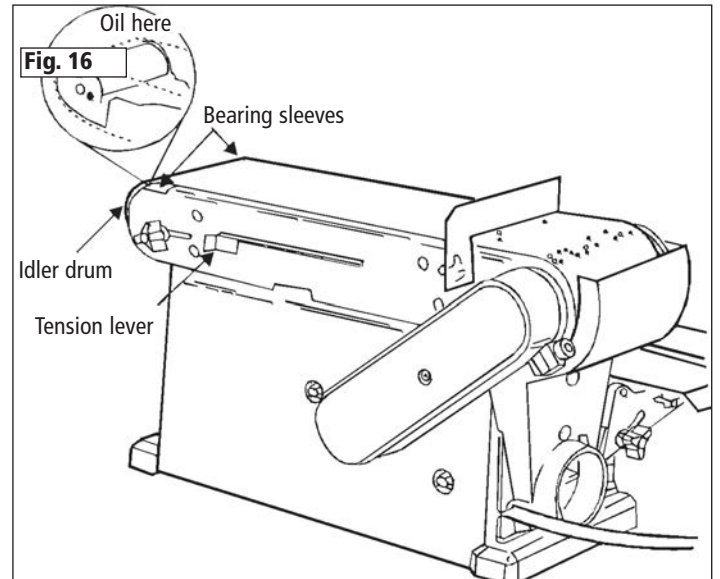
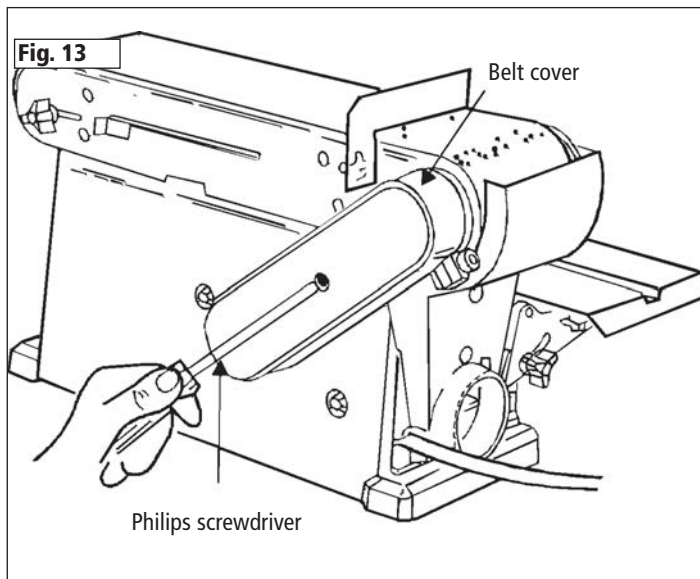
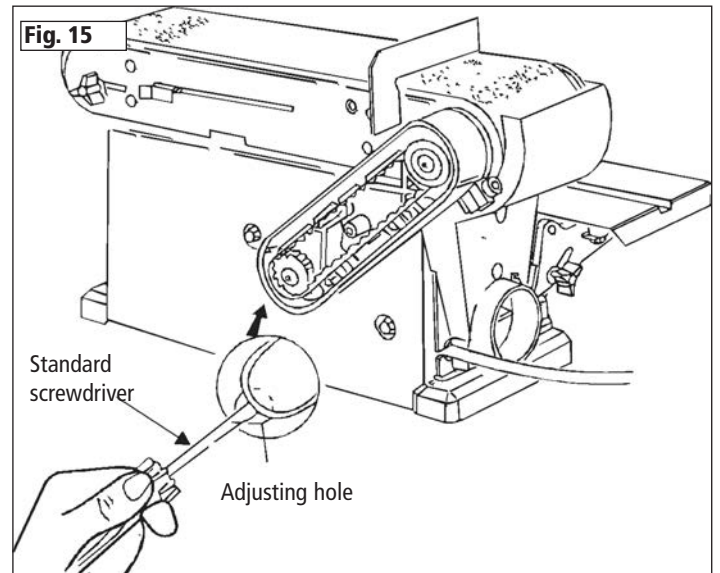
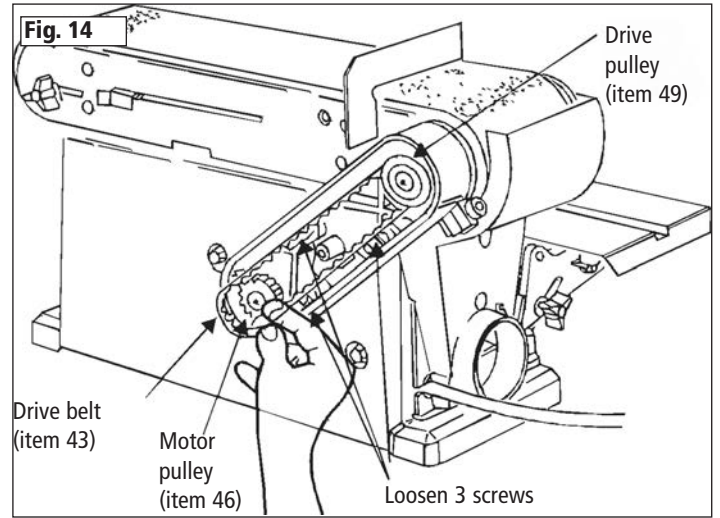



# 9. Dust Extraction

## The Importance Of Dust Extraction

Before the machine is started, ensure that adequate dust extraction provisions have been installed. Dust extraction is extremely important not only for health and safety but also for the correct upkeep of the machine. Saw dust can cause the machine not to operate properly or even fail completely. By keeping the machine free of large amounts of waste the performance will be optimised. If a large amounts of MDF or toxic woods are to be cut we recommend that there is a good ventilation system in place and that in addition to proper extraction a mask or respirator be worn as minimum protection.

## Record Power Extractors

Record Power offer a range of high quality dust extractors, we offer both drum and bag type extractors which filter down 0.5 micron providing protection from harmful fine dusts. All Record Power dust extractors & chip collectors have 100 mm inlets and hoses.

### DX1000 High Filtration Dust Extractor

Drum type extractor, 45 litre capacity, single 1 kW motor, suitable for intermittent use ie must be switched off for 20 minutes every hour.  
**0.5 micron filtration**

### RSDE1 High Filtration Dust Extractor

Drum type extractor, 45 litre capacity, single 1 kW motor, suitable for intermittent use ie must be switched off for 20 minutes every hour.  
**0.5 micron filtration**

### RSDE2 High Filtration Dust Extractor

Drum type extractor, 50 litre capacity, single 1 kW motor, suitable for intermittent use ie must be switched off for 20 minutes every hour.  
**0.5 micron filtration**

### RSDE/2A High Filtration Dust Extractor with Auto Switching

Drum type extractor, 50 litre capacity, single 1 kW motor, auto switching allows the machine to be turned on and off as machines and power tools are operated. Suitable for intermittent use ie must be switched off for 20 minutes every hour. Maximum auto switch capacity 1.1 kW.  
**0.5 micron filtration**

### DX4000 High Filtration Dust Extractor

Drum type extractor, 80 litre capacity, Twin 1 kW motor, suitable for heavy usage ie if one motor is switched off for 20 minutes then the other can be used thus enabling continuous usage. Or both motors can be used simultaneously giving maximum suction but in this mode the extractor must be switched off for 20 minutes every hour. **0.5 micron filtration**

### DX5000 High Filtration Dust Extractor

Bag type extractor, 200 litre capacity, Twin 1 kW motor, suitable for heavy usage ie if one motor is switched off for 20 minutes then the other can be used thus enabling continuous usage. Or both motors can be used simultaneously giving maximum suction but in this mode the extractor must be switched off for 20 minutes every hour. **0.5 micron filtration**

### CX2600 Chip Collector

Large capacity chip collector, with a powerful 0.37 kW induction motor. An extremely smooth running unit suitable for continuous usage. Very quiet impeller system extracts dust and chippings.

**Suitable for chip collection or finer dust using the optional filter cartridge**

### CX3000 Chip Collector

Larger capacity chip collector, with a more powerful 0.75 kW induction motor and heavy duty construction. An extremely smooth running unit suitable for continuous usage. Very quiet impeller system extracts dust and chippings.

**Suitable for chip collection or finer dust using the optional filter cartridge**

### Air Cleaners

It is strongly advised to also use an air cleaner to remove the fine airborne dust present in the workshop which cannot be removed using machine extraction. Record Power offer a range of air cleaners suitable for all home workshops. Please contact your preferred stockist or call customer services in your country.

	DX1000	RSDE1	RSDE2	RSDE/2A	DX4000	DX5000	CX2600	CX3000
<b>Bandsaws Circular saws Sanders</b> Intermittent usage	✓ Recommended	✓ Recommended	✓ Recommended	✓ Recommended	✓ Recommended	✓ Recommended		
<b>Bandsaws Circular saws Sanders</b> Heavy usage					✓ Recommended	✓ Recommended		
<b>Planer Thicknessers Spindle Moulders Universals</b> Intermittent usage	✓ Recommended	✓ Recommended			✓ Can be used	✓ Recommended	✓ Recommended	✓ Recommended
<b>Planer Thicknessers Spindle Moulders Universals</b> Heavy usage					✓ Can be used	✓ Recommended	✓ Recommended	✓ Recommended
<b>Dust Extraction System</b> Intermittent usage					✓ Can be used	✓ Recommended		

# 10. Trouble Shooting

<b>Fault</b>	<b>Diagnosis</b>	<b>Remedy</b>
Sander does not operate	Not plugged in to or switched on at power outlet	Plug in to or switch on at power outlet
	Fuse blown	Check/change fuse
	Power switch defective	Replace switch
	Drive belt broken	Replace drive belt
	Motor or wiring problem	Have qualified electrician carry out repair
Motor slows when sanding	Timing belt too tight	Decrease tension
Wood burns while sanding	Applying too much pressure on workpiece	Apply less pressure to workpiece when sanding
Sander makes excessive noise	Sanding disc or belt is loaded with debris	Clean or replace disc or belt
	Timing belt too tight	Decrease tension
	Bearings need oil	Oil bearings

# 11. Electrical Connection & Wiring Diagram

Machines supplied for use in the UK are fitted with a 3 pin plug conforming to BS1363, fitted with a fuse conforming to BS1362 and appropriate to the current rating of the machine.

Machines supplied for use in other countries within the European Union are fitted with a 2 pin Schuko plug conforming to CEE 7/7.

Machines supplied for use in Australia & New Zealand are fitted with a 3 pin plug conforming to AS/NZS3112.

In all cases, if the original plug or connector has to be replaced for any reason, the wires within the mains power cable are colour coded as follows:

## 230 V (Single Phase)

Brown: Live (L)  
 Blue: Neutral (N)  
 Green and Yellow: Earth (E)

The wire coloured brown must always be connected to the terminal marked 'L' or coloured red.

The wire coloured blue must always be connected to the terminal marked 'N' or coloured black.

The wire coloured green and yellow must always be connected to the terminal marked 'E' or with the earth symbol:



or coloured green / green and yellow.

It is important that the machine is effectively earthed. Some machines will be clearly marked with the double insulated logo:



In this case there will not be an earth wire within the circuit.

In the case of the BS1363 plug for use in the UK, always ensure that it is fitted with a fuse conforming to BS1362 appropriate to the rating of the

machine. If replacing the original fuse, always fit a fuse of equivalent rating to the original. Never fit a fuse of a higher rating than the original. Never modify the fuse or fuse holder to accept fuses of a different type or size.

Where the current rating of the machine exceeds 13 A at 230 V, or if the machine is designated for use on a 400 V 3 phase supply a connector conforming to BS4343 (CEE17 / IEC60309) will be used.

230 V machines will be fitted with a blue 3 pin connector. The wiring for this type of this connector will be the same as shown above.

400 V, 3 phase machines will be fitted with a red 4 or 5 pin connector. The wiring for this type of connector is as shown below:

## 400 V (3 phase)

Brown: Live (L1)  
 Black: Live (L2)  
 Grey: Live (L 3)  
 Blue: Neutral (N)  
 Green and Yellow: Earth (E)

The wire coloured brown must always be connected to the terminal marked 'L1'.

The wire coloured black must always be fitted to the terminal marked 'L2'.

The wire coloured grey must always be connected to the terminal marked 'L3'.

The wire coloured blue must always be connected to the terminal marked 'N' or coloured black.

The wire coloured green and yellow must always be connected to the terminal marked 'E' or with the earth symbol

If in doubt about the connection of the electrical supply, always consult a qualified electrician.

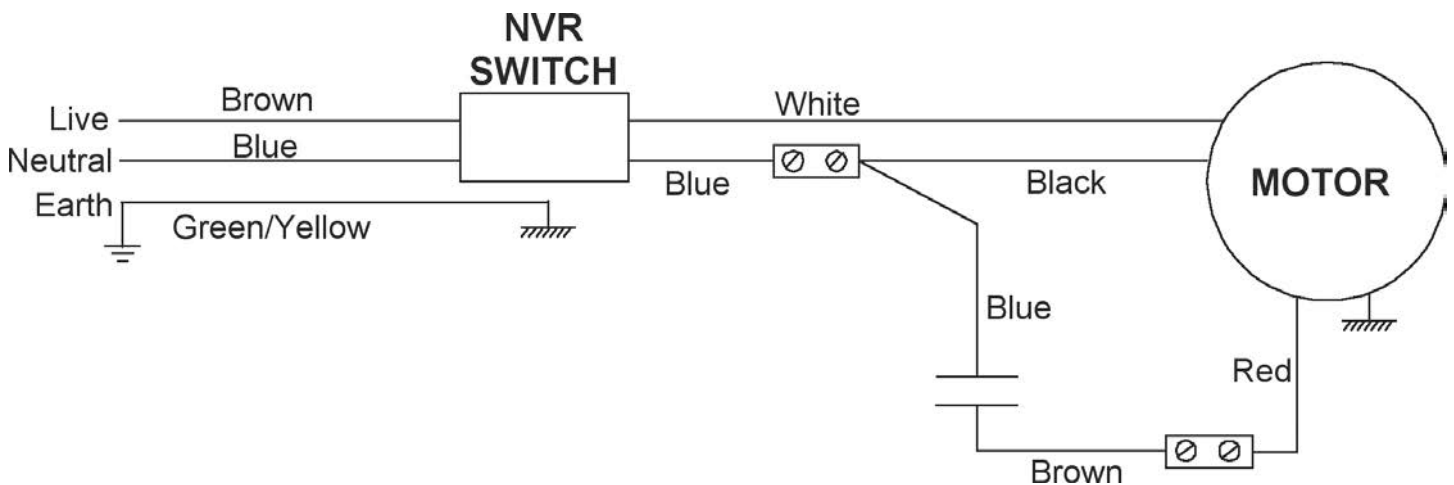

# 12. Parts Diagram

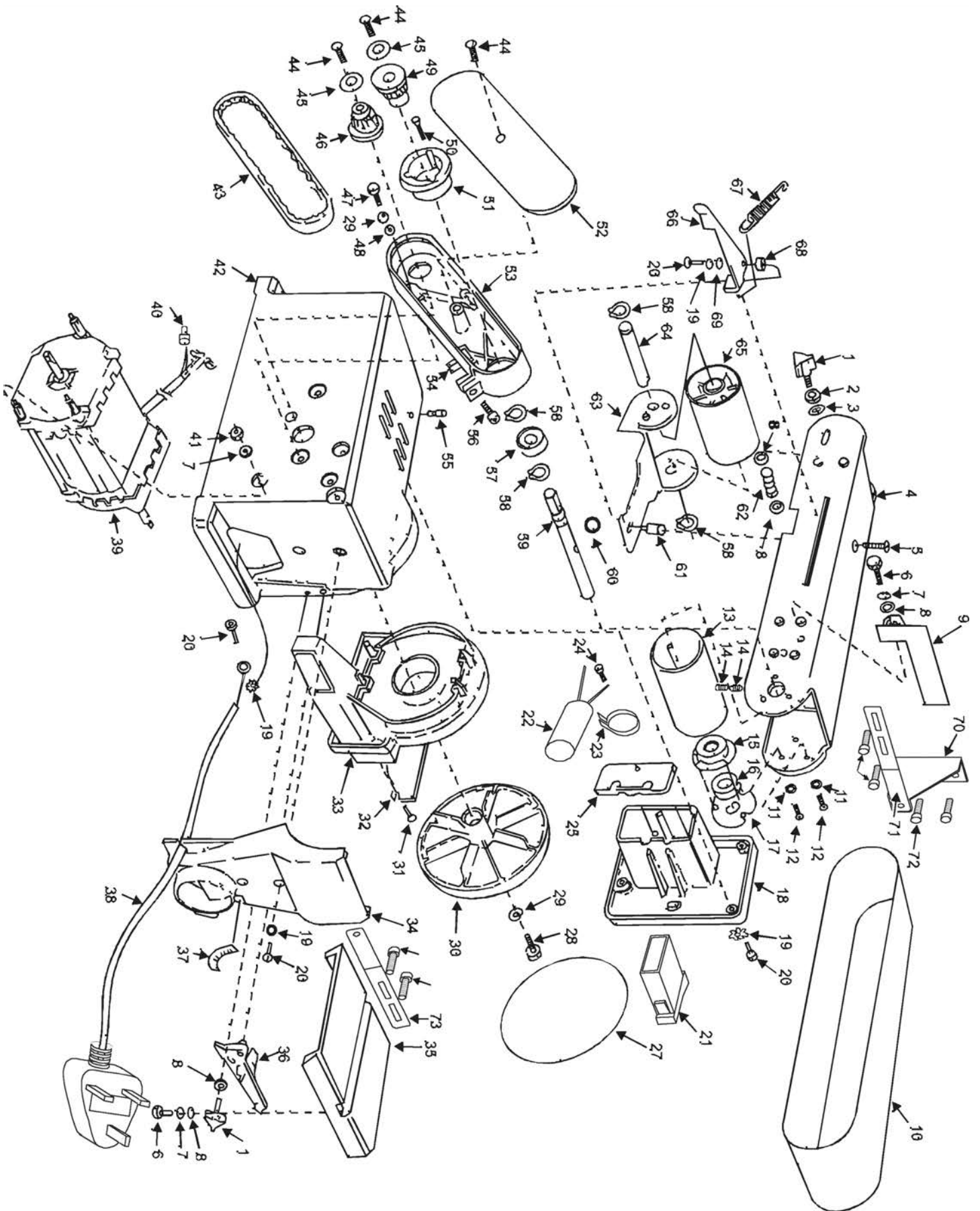

# 13. Parts List

1	Table knob	38	Cord with plug
2	Washer – rubber	39	Motor (1/3 HP)
3	Washer – notched	40	Wire connector
4	Bed	41	Nut – Hex. M6
5	Screw – Flat cross, M5 x 35 mm	42	Base
6	Screw – Hex. M6 x 14mm	43	Timing belt
7	Lock washer – Ext. M6	44	Screw – Flat cross, M5 x 10 mm
8	Washer – 16.5 mm x 17.8 mm x 1.6 mm	45	Countersink washer
9	Work support	46	Motor pulley
10	Sanding belt – 4" x 36"	47	Screw – Pan head, M6 x 25mm
11	Lock washer	48	Washer – M6 x 12 mm x 1.6 mm
12	Screw – Pan head, M5 x 8 mm	49	Drive pulley
13	Drive drum	50	Screw – Flat head, M5 x 25mm
14	Screw – Socket, M8 x 10 mm	51	Bearing support
15	Bearing cap	52	Belt cover
16	Bearing with flat washer	53	Belt housing
17	Bearing spacer	54	Nut – Square, M8 x 1.25 mm
18	Switch housing	55	Rubber bumper
19	Lock washer – External, M5	56	Screw – Hex. Socket cap, M8 x 25mm
20	Screw – Pan head, M5 x 16 mm	57	Ball bearing
21	No-Volt release switch	58	Retaining ring – M12
22	Capacitor	59	Drive shaft
23	Holder for capacitor	60	Nut – Hex. Flange, M5
24	Screw – Pan cross, type 'AB', M4 x 30 mm	61	Guide spacer
25	Switch box cover	62	Index spring
27	Pad – 6" dia. sandpaper	63	Drum guide
28	Screw – Pan cross, M6 x 12 mm	64	Idler shaft
29	Lock washer – helical M6	65	Idler drum
30	Plate	66	Tension lever
31	Screw – Pan head, type 'AB', M4 x 12 mm	67	Tension spring
32	Disc guard	68	Lever spacer
33	Disc shroud	69	Washer – M5 x 15 mm x 1.2 mm
34	Dust collector	70	Sanding bed table support
35	Table	71	Extra table support bracket
36	Table support	72	Screw – Pan head, M5 x 8 mm
37	Angle scale	73	Right hand table support bracket



# EU Declaration of Conformity

**Cert No: EU / BDS150 / 1**

**RECORD POWER LIMITED,**

Centenary House, 11 Midland Way, Barlborough Links,  
Chesterfield, Derbyshire S43 4XA

declares that the machinery described:-

1. Type: Belt & Disc Sander
2. Model No: BDS150
3. Serial No .....

Conforms with the following directives:-

MACHINERY DIRECTIVE	2006/42/EC
LOW VOLTAGE DIRECTIVE	2006/95/EC
ELECTROMAGNETIC COMPATIBILITY DIRECTIVE	2004/108/EC EN 55014-1:2006 EN 61000-3-2:2006 EN 61000-3-3:1995+A1+A2 EN 55014-2:1997+A1

and conforms to the machinery example for which the  
EC Type-Examination Certificate No. AM50154063, AN50154062 and AE50136031  
has been issued by TUV Rheinland Product Safety GmbH,  
at: Am Grauen Stein, D-51105. Cologne, Germany

and complies with the relevant essential health and safety requirements.



Signed.....Dated: **01/01/2013**

**Andrew Greensted**  
Managing Director

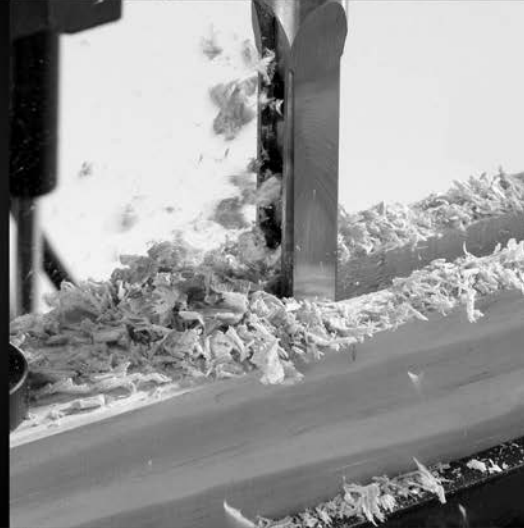

# RECORD POWER

ESTABLISHED 1909®

## Woodworking Machinery & Accessories

### United Kingdom

#### Record Power Ltd

Centenary House, 11 Midland Way  
Barlborough Links, Chesterfield  
Derbyshire S43 4XA

Tel: 01246 571 020

Fax: 01246 571 030

[www.recordpower.co.uk](http://www.recordpower.co.uk)

### Eire

#### Record Power Ltd

Centenary House, 11 Midland Way  
Barlborough Links, Chesterfield  
Derbyshire S43 4XA

Tel: 01246 571 020

Fax: 01246 571 030

[www.recordpower.co.uk](http://www.recordpower.co.uk)

### Australia

#### Tools 4 Industry

Po Box 3844  
Parramatta 2124

Tel: 1300 124 422

Fax: 1800 262 725

[www.recordpower.com.au](http://www.recordpower.com.au)

### New Zealand

#### Tools 4 Industry

Po Box 276079  
Manukau City 2241

Tel: 0800 142 326

Fax: 09 2717 237

[www.recordpower.co.nz](http://www.recordpower.co.nz)