

**Robert Bosch GmbH**  
Power Tools Division  
70745 Leinfelden-Echterdingen  
Germany

[www.bosch-pt.com](http://www.bosch-pt.com)

**1 609 92A 08N** (2013.03) PS / 61 EURO



1 609 92A 08N

## TE 600

 **BOSCH**

<b>de</b> Originalbetriebsanleitung	<b>tr</b> Orijinal işletme talimatı	<b>mk</b> Оригинално упатство за работа
<b>en</b> Original instructions	<b>pl</b> Instrukcja oryginalna	<b>sr</b> Originalno uputstvo za rad
<b>fr</b> Notice originale	<b>cs</b> Původní návod k používání	<b>sl</b> Izvirna navodila
<b>es</b> Manual original	<b>sk</b> Pôvodný návod na použitie	<b>hr</b> Originalne upute za rad
<b>pt</b> Manual original	<b>hu</b> Eredeti használati utasítás	<b>et</b> Algupärane kasutusjuhend
<b>it</b> Istruzioni originali	<b>ru</b> Оригинальное руководство по эксплуатации	<b>lv</b> Instrukcijas oriģinālvalodā
<b>nl</b> Oorspronkelijke gebruiksaanwijzing	<b>uk</b> Оригінальна інструкція з експлуатації	<b>lt</b> Originali instrukcija
<b>da</b> Original brugsanvisning	<b>kk</b> Пайдалану нұсқаулығының түпнұсқасы	<b>ar</b> تعليمات التشغيل الأصلية
<b>sv</b> Bruksanvisning i original	<b>ro</b> Instrucțiuni originale	<b>fa</b> دفتزچه راهنمای اصلی
<b>no</b> Original driftsinstruks	<b>bg</b> Оригинална инструкция	
<b>fi</b> Alkuperäiset ohjeet		
<b>el</b> Πρωτότυπο οδηγιών χρήσης		



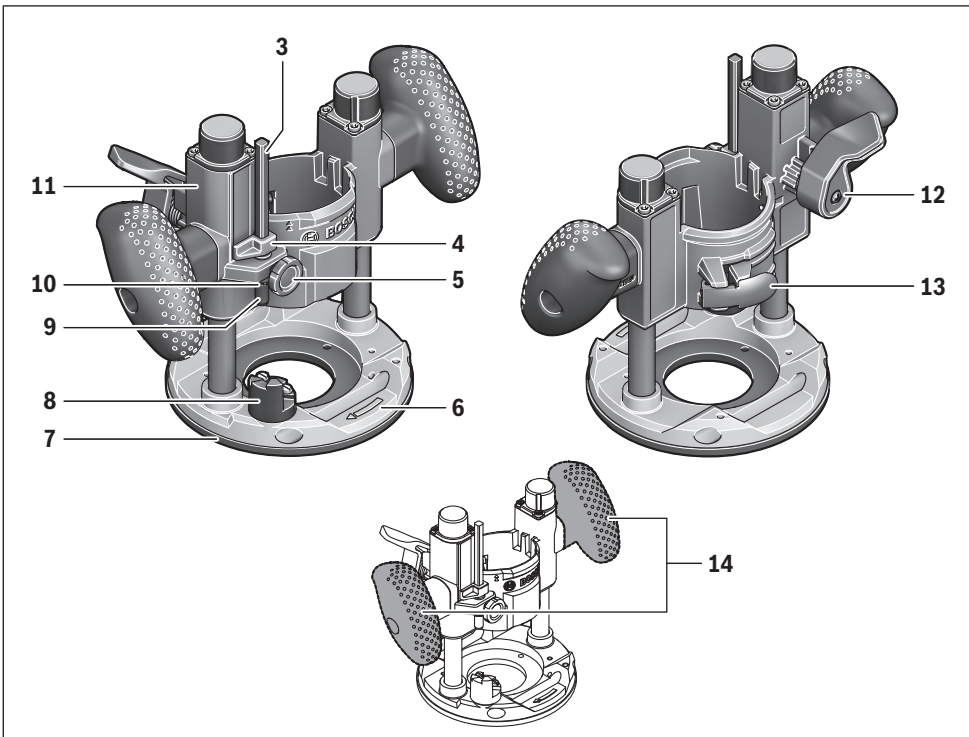
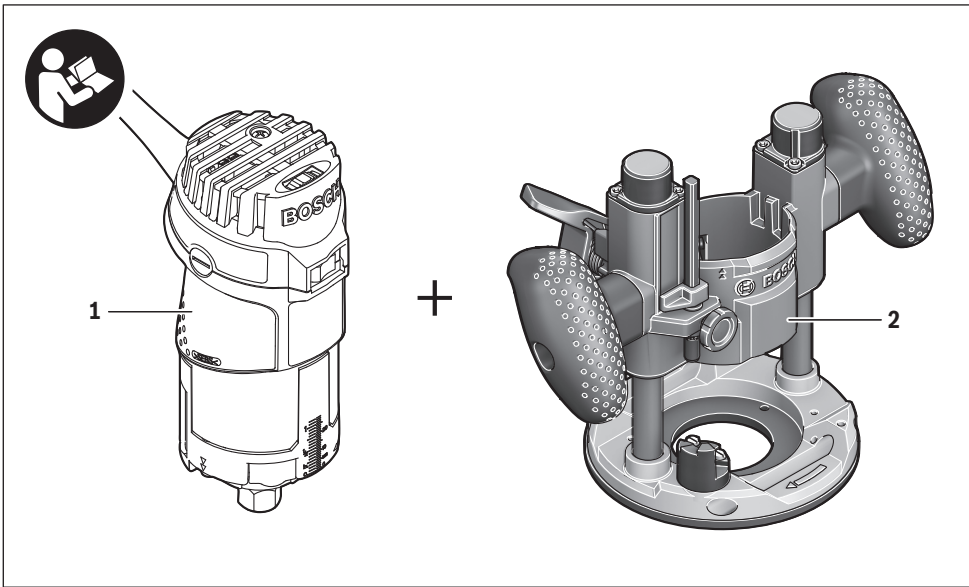

4 |

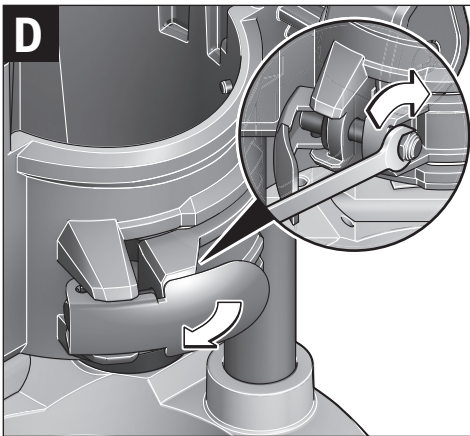
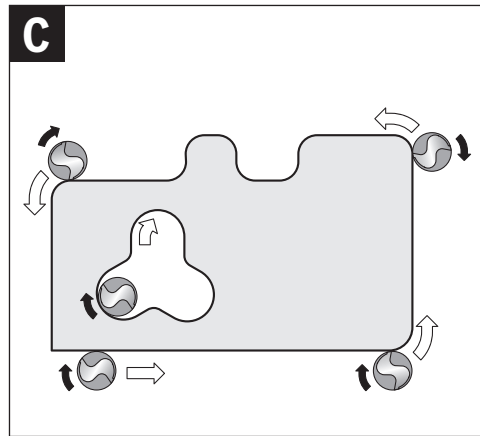
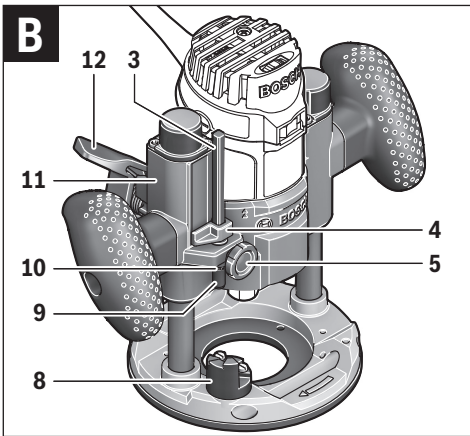
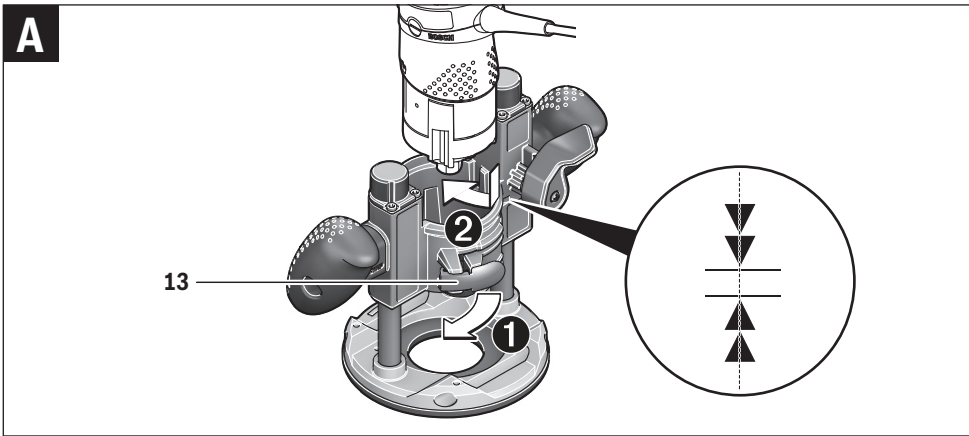

## 6 | English

**Frästiefe einstellen mit Schablone**

Als Schablone verwenden Sie das Einbauteil, für das die Vertiefung gefräst werden soll, z. B. ein Scharnier.

- Stellen Sie den Revolveranschlag **8** auf die niedrigste Stufe; der Revolveranschlag rastet spürbar ein.
- Legen Sie das Einbauteil auf die niedrigste Stufe des Revolveranschlags.
- Lösen Sie die Rändelschraube am Tiefenanschlag **5**, so dass der Tiefenanschlag **3** frei beweglich ist.
- Drücken Sie den Tiefenanschlag nach unten, bis er auf dem Einbauteil aufsitzt und ziehen Sie die Rändelschraube am Tiefenanschlag fest.
- Nehmen Sie das Einbauteil vom Revolveranschlag.

**Arbeitshinweise****Fräsrichtung und Fräsvorgang (siehe Bild C)**

► **Der Fräsvorgang muss stets gegen die Umlaufrichtung des Fräasers erfolgen (Gegenlauf). Beim Fräsen mit der Umlaufrichtung (Gleichlauf) kann Ihnen das Elektrowerkzeug aus der Hand gerissen werden.**

Zum Fräsen mit der Taucheinheit **2** gehen Sie wie folgt vor:

- Stellen Sie die gewünschte Frästiefe ein, siehe Abschnitt „Frästiefe einstellen“.
- Setzen Sie das Elektrowerkzeug mit montiertem Fräser auf das zu bearbeitende Werkstück und schalten Sie das Elektrowerkzeug ein.
- Drücken Sie den Entriegelungshebel für Tauchfunktion **12** und führen Sie die Kantenfräse langsam nach unten, bis die eingestellte Frästiefe erreicht ist. Lassen Sie den Entriegelungshebel **12** wieder los, um diese Eintauchtiefe zu fixieren.
- Führen Sie den Fräsvorgang mit gleichmäßigem Vorschub aus.
- Führen Sie nach Beendigung des Fräsvorgangs die Kantenfräse in die oberste Position zurück.
- Schalten Sie das Elektrowerkzeug aus.

**Spannhebel nachstellen (siehe Bild D)**

Wenn die Antriebseinheit **1** nicht mehr fest in der Taucheinheit sitzt, müssen Sie die Spannkraft des Spannhebels **13** nachstellen.

- Öffnen Sie den Spannhebel.
- Drehen Sie die Mutter mit einem Gabelschlüssel (8 mm) ca. 45° im Uhrzeigersinn.
- Schließen Sie den Spannhebel wieder.
- Überprüfen Sie, ob die Antriebseinheit sicher gespannt wird. Ziehen Sie die Mutter nicht zu fest.

**Wartung und Service****Kundendienst und Anwendungsberatung**

Der Kundendienst beantwortet Ihre Fragen zu Reparatur und Wartung Ihres Produkts sowie zu Ersatzteilen. Explosionszeichnungen und Informationen zu Ersatzteilen finden Sie auch unter:

**www.bosch-pt.com**

Das Bosch-Anwendungsberatungs-Team hilft Ihnen gerne bei Fragen zu unseren Produkten und deren Zubehör.

**www.powertool-portal.de**, das Internetportal für Handwerker und Heimwerker.

**Deutschland**

Robert Bosch GmbH  
Servicezentrum Elektrowerkzeuge  
Zur Luhne 2  
37589 Kalefeld – Willershausen  
Unter [www.bosch-pt.com](http://www.bosch-pt.com) können Sie online Ersatzteile bestellen oder Reparaturen anmelden.  
Kundendienst: Tel.: (0711) 40040480  
Fax: (0711) 40040481  
E-Mail: [Servicezentrum.Elektrowerkzeuge@de.bosch.com](mailto:Servicezentrum.Elektrowerkzeuge@de.bosch.com)  
Anwendungsberatung: Tel.: (0711) 40040480  
Fax: (0711) 40040482  
E-Mail: [Anwendungsberatung.pt@de.bosch.com](mailto:Anwendungsberatung.pt@de.bosch.com)

**Österreich**

Tel.: (01) 797222010  
Fax: (01) 797222011  
E-Mail: [service.elektrowerkzeuge@at.bosch.com](mailto:service.elektrowerkzeuge@at.bosch.com)

**Schweiz**

Tel.: (044) 8471511  
Fax: (044) 8471551  
E-Mail: [AfterSales.Service@de.bosch.com](mailto:AfterSales.Service@de.bosch.com)

**Luxemburg**

Tel.: +32 2 588 0589  
Fax: +32 2 588 0595  
E-Mail: [outillage.gereedschap@be.bosch.com](mailto:outillage.gereedschap@be.bosch.com)

**Entsorgung**

Taucheinheit, Zubehör und Verpackungen sollen einer umweltgerechten Wiederverwertung zugeführt werden.

**Änderungen vorbehalten.****English****General Safety Rules**

**Read all precautions and instructions enclosed with the plunge base and the power tool you are using.** Failure to comply with the safety information and instructions can cause electric shock, fire and/or severe injury.

**Save all safety warnings and all instructions for future reference.**

**Product Description and Specifications****Intended Use**

In conjunction with the Bosch Edge Router GKF 600, the plunge base is intended for routing grooves, profiles and elongated holes in wood, plastic and light building materials, while resting firmly on the workpiece.

## Product Features

The numbering of the product features refers to the illustrations on the graphics pages.

- 1 Motor unit
- 2 Plunge base
- 3 Depth stop
- 4 Slide with index mark
- 5 Knurled screw for depth stop
- 6 Base plate
- 7 Guide plate
- 8 Turret stop
- 9 Sleeve for depth-of-cut fine adjustment
- 10 Scale for depth-of-cut fine adjustment
- 11 Scale for depth-of-cut
- 12 Release lever for plunge action
- 13 Clamping lever
- 14 Handle (insulated gripping surface)

The accessories illustrated or described are not included as standard delivery.

## Assembly

- ▶ Before any work on the machine itself, pull the mains plug.

### Inserting Motor Unit in Plunge Base (see figure A)

- Release clamping lever **13**, if tightened.
- Bring the two double arrows on the motor unit and plunge base **2** into alignment.
- Slide the motor unit all the way into the plunge base and turn the motor unit in a clockwise direction as far as possible.
- Lock the clamping lever.
- ▶ After assembly, always check that the motor unit is firmly seated in the plunge base.

## Operation

### Adjusting the Depth-of-cut (see figure B)

- ▶ The adjustment of the depth-of-cut may only be carried out when the router is switched off.

#### Coarse Adjustment of Depth-of-cut

- Place the machine with the router bit mounted on the workpiece to be machined.
- Set the scale for fine adjustment **10** to “0”.
- Set the turret stop **8** to the lowest setting; the turret stop can be felt to engage.
- Loosen the knurled screw at depth stop **5**, so that the depth stop **3** moves freely.
- Press the release lever for plunge action **12** and slowly guide the edge router down until the router bit touches the workpiece surface. Let go of the release lever **12** again to lock this plunging depth.

- Push the depth stop **3** down until it faces against the turret stop **8**. Set the slide with the index mark **4** to the “0” position on the scale for depth-of-cut adjustment **11**.
- Set the depth stop **3** to the desired routing depth and tighten the knurled screw **5** for the depth stop. Take care not to misadjust the slide with the index mark **4**.
- Press the release lever for plunge action **12** and guide the edge router to the uppermost position.

The set routing depth is only reached when depth stop **3** touches the turret stop **8** while plunging.

For deep cuts, it is recommended to carry out several cuts, each with little material removal. By using the turret stop **8**, the cutting process can be divided into several steps. For this, adjust the desired depth-of-cut to the lowest step of the turret stop and select the higher steps first for the initial cuts. The clearance of the steps is approx. 3 mm.

#### Fine Adjustment of Depth-of-cut

After a test run, the depth-of-cut can be set to the required dimension by turning the sleeve **9**; turning in a clockwise direction increases the depth-of-cut; turning in an anticlockwise direction decreases the depth-of-cut. The scale **10** can be used for guidance. One revolution corresponds to an adjustment range of approximately 1 mm, the maximum adjustment range is approximately 4 mm.

If the plunge base **2** has gone down to the maximum plunge depth, a large plunge depth cannot be reached via the fine adjustment, as the maximum adjustment range was used.

A fine adjustment is not possible, when the depth stop **3** touches against the turret stop **8**.

#### Adjusting the Depth-of-cut with Template

As a template, use the built-in part, for which the cavity is to be routed, e.g. a hinge.

- Set the turret stop **8** to the lowest setting; the turret stop can be felt to engage.
- Place the built-in part on the lowest step of the turret stop.
- Loosen the knurled screw at depth stop **5**, so that the depth stop **3** moves freely.
- Push the depth stop down until it sits on the built-in part and tighten the knurled screw on the depth stop.
- Remove the built-in part from the turret stop.

## Working Advice

### Direction of Feed and Routing Process (see figure C)

- ▶ The routing process must always be carried out against the rotation direction of the router bit (up-cutting motion). When routing in the direction with the rotation of the router (down-cutting), the machine can break loose, eliminating control by the user.

For routing with the plunge base **2**, proceed as follows:

- Adjust the required depth-of-cut; see Section “Adjusting the Depth-of-cut”.
- Place the machine with the router bit mounted on the workpiece to be machined and switch the power tool on.
- Press the release lever for plunge action **12** and slowly guide the edge router down until the router bit touches the workpiece surface. Let go of the release lever **12** again to fix this plunge depth.

**8 | English**

- Carry out the routing process applying uniform feed.
- After finishing the routing process, guide the edge router back to the uppermost position.
- Switch the power tool off.

**Readjusting the Clamping Lever (see figure D)**

If the motor unit **1** is no longer firmly seated in the plunge base, you must readjust the tightening tension of the clamping lever **13**.

- Open the clamping lever.
- Turn nut approx. 45° in clockwise direction with an open-end spanner (size 8 mm).
- Tighten the clamping lever again.
- Check if the motor unit is clamped securely. Do not over-tighten the nut.

**Maintenance and Service****After-sales Service and Application Service**

Our after-sales service responds to your questions concerning maintenance and repair of your product as well as spare parts. Exploded views and information on spare parts can also be found under:

**www.bosch-pt.com**

Bosch's application service team will gladly answer questions concerning our products and their accessories.

**Great Britain**

Robert Bosch Ltd. (B.S.C.)  
P.O. Box 98  
Broadwater Park  
North Orbital Road  
Denham  
Uxbridge  
UB 9 5HJ  
Tel. Service: (0844) 7360109  
Fax: (0844) 7360146  
E-Mail: boschservicecentre@bosch.com

**Ireland**

Origo Ltd.  
Unit 23 Magna Drive  
Magna Business Park  
City West  
Dublin 24  
Tel. Service: (01) 4666700  
Fax: (01) 4666888

**Australia, New Zealand and Pacific Islands**

Robert Bosch Australia Pty. Ltd.  
Power Tools  
Locked Bag 66  
Clayton South VIC 3169  
Customer Contact Center  
Inside Australia:  
Phone: (01300) 307044  
Fax: (01300) 307045  
Inside New Zealand:  
Phone: (0800) 543353  
Fax: (0800) 428570  
Outside AU and NZ:  
Phone: +61 3 95415555  
www.bosch.com.au

**Republic of South Africa****Customer service**

Hotline: (011) 6519600

**Gauteng – BSC Service Centre**

35 Roper Street, New Centre  
Johannesburg  
Tel.: (011) 4939375  
Fax: (011) 4930126  
E-Mail: bsctools@icon.co.za

**KZN – BSC Service Centre**

Unit E, Almar Centre  
143 Crompton Street  
Pinetown  
Tel.: (031) 7012120  
Fax: (031) 7012446  
E-Mail: bsc.dur@za.bosch.com

**Western Cape – BSC Service Centre**

Democracy Way, Prosperity Park  
Milnerton  
Tel.: (021) 5512577  
Fax: (021) 5513223  
E-Mail: bsc@zsd.co.za

**Bosch Headquarters**

Midrand, Gauteng  
Tel.: (011) 6519600  
Fax: (011) 6519880  
E-Mail: rbsa-hq.pts@za.bosch.com

**Disposal**

The plunge base, accessories and packaging should be sorted for environmentally friendly recycling.

**Subject to change without notice.**