

Robert Bosch GmbH

Power Tools Division
70745 Leinfelden-Echterdingen
Germany

www.bosch-pt.com

2 609 932 936 (2014.04) T / 197 EURO



2 609 932 936

GST Professional

150 CE | 150 BCE



de Originalbetriebsanleitung
en Original instructions
fr Notice originale
es Manual original
pt Manual original
it Istruzioni originali
nl Oorspronkelijke
gebruiksaanwijzing
da Original brugsanvisning
sv Bruksanvisning i original
no Original driftsinstruks
fi Alkuperäiset ohjeet
el Πρωτότυπο οδηγίων χρήσης

tr Orijinal işletme talimatı
pl Instrukcja oryginalna
cs Původní návod k používání
sk Pôvodný návod na použitie
hu Eredeti használati utasítás
ru Оригинальное руководство по
эксплуатации
uk Оригінальна інструкція з
експлуатації
kk Пайдалану нұсқаулығының
түпнұсқасы
ro Instrucțiuni originale
bg Оригинална инструкция

mk Оригинално упатство за работа
sr Originalno uputstvo za rad
sl Izvirna navodila
hr Originalne upute za rad
et Algupärane kasutusjuhend
lv Instrukcijas oriģinālvalodā
lt Originali instrukcija
ar تعليمات التشغيل الأصلية
fa دفترچه راهنمای اصلی



English

General Power Tool Safety Warnings

⚠ WARNING Read all safety warnings and all instructions. Failure to follow the warnings and instructions may result in electric shock, fire and/or serious injury.

Save all warnings and instructions for future reference.

The term "power tool" in the warnings refers to your mains-operated (corded) power tool or battery-operated (cordless) power tool.

Work area safety

- ▶ **Keep work area clean and well lit.** Cluttered or dark areas invite accidents.
- ▶ **Do not operate power tools in explosive atmospheres, such as in the presence of flammable liquids, gases or dust.** Power tools create sparks which may ignite the dust or fumes.
- ▶ **Keep children and bystanders away while operating a power tool.** Distractions can cause you to lose control.

Electrical safety

- ▶ **Power tool plugs must match the outlet. Never modify the plug in any way. Do not use any adapter plugs with earthed (grounded) power tools.** Unmodified plugs and matching outlets will reduce risk of electric shock.
- ▶ **Avoid body contact with earthed or grounded surfaces, such as pipes, radiators, ranges and refrigerators.** There is an increased risk of electric shock if your body is earthed or grounded.
- ▶ **Do not expose power tools to rain or wet conditions.** Water entering a power tool will increase the risk of electric shock.
- ▶ **Do not abuse the cord. Never use the cord for carrying, pulling or unplugging the power tool. Keep cord away from heat, oil, sharp edges and moving parts.** Damaged or entangled cords increase the risk of electric shock.
- ▶ **When operating a power tool outdoors, use an extension cord suitable for outdoor use.** Use of a cord suitable for outdoor use reduces the risk of electric shock.
- ▶ **If operating a power tool in a damp location is unavoidable, use a residual current device (RCD) protected supply.** Use of an RCD reduces the risk of electric shock.

Personal safety

- ▶ **Stay alert, watch what you are doing and use common sense when operating a power tool. Do not use a power tool while you are tired or under the influence of drugs, alcohol or medication.** A moment of inattention while operating power tools may result in serious personal injury.
- ▶ **Use personal protective equipment. Always wear eye protection.** Protective equipment such as dust mask, non-skid safety shoes, hard hat, or hearing protection used for appropriate conditions will reduce personal injuries.

- ▶ **Prevent unintentional starting. Ensure the switch is in the off-position before connecting to power source and/or battery pack, picking up or carrying the tool.** Carrying power tools with your finger on the switch or energising power tools that have the switch on invites accidents.
- ▶ **Remove any adjusting key or wrench before turning the power tool on.** A wrench or a key left attached to a rotating part of the power tool may result in personal injury.
- ▶ **Do not overreach. Keep proper footing and balance at all times.** This enables better control of the power tool in unexpected situations.
- ▶ **Dress properly. Do not wear loose clothing or jewelry. Keep your hair, clothing and gloves away from moving parts.** Loose clothes, jewellery or long hair can be caught in moving parts.
- ▶ **If devices are provided for the connection of dust extraction and collection facilities, ensure these are connected and properly used.** Use of dust collection can reduce dust-related hazards.

Power tool use and care

- ▶ **Do not force the power tool. Use the correct power tool for your application.** The correct power tool will do the job better and safer at the rate for which it was designed.
- ▶ **Do not use the power tool if the switch does not turn it on and off.** Any power tool that cannot be controlled with the switch is dangerous and must be repaired.
- ▶ **Disconnect the plug from the power source and/or the battery pack from the power tool before making any adjustments, changing accessories, or storing power tools.** Such preventive safety measures reduce the risk of starting the power tool accidentally.
- ▶ **Store idle power tools out of the reach of children and do not allow persons unfamiliar with the power tool or these instructions to operate the power tool.** Power tools are dangerous in the hands of untrained users.
- ▶ **Maintain power tools. Check for misalignment or binding of moving parts, breakage of parts and any other condition that may affect the power tool's operation. If damaged, have the power tool repaired before use.** Many accidents are caused by poorly maintained power tools.
- ▶ **Keep cutting tools sharp and clean.** Properly maintained cutting tools with sharp cutting edges are less likely to bind and are easier to control.
- ▶ **Use the power tool, accessories and tool bits etc. in accordance with these instructions, taking into account the working conditions and the work to be performed.** Use of the power tool for operations different from those intended could result in a hazardous situation.

Service

- ▶ **Have your power tool serviced by a qualified repair person using only identical replacement parts.** This will ensure that the safety of the power tool is maintained.

Safety Warnings for Jigsaws











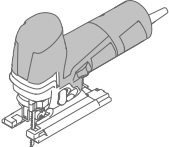
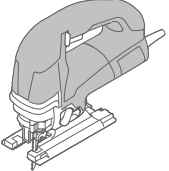

- ▶ **Hold power tool by insulated gripping surfaces, when performing an operation where the cutting accessory may contact hidden wiring or its own cord.** Cutting accessory contacting a "live" wire may make exposed metal parts of the power tool "live" and could give the operator an electric shock.















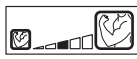

Additional Safety and Working Instructions

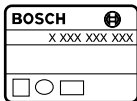
- ▶ **Keep hands away from the sawing range. Do not reach under the workpiece.** Contact with the saw blade can lead to injuries.
- ▶ **Apply the machine to the workpiece only when switched on.** Otherwise there is danger of kickback when the cutting tool jams in the workpiece.
- ▶ **Pay attention that the base plate rests securely on the material while sawing.** A jammed saw blade can break or lead to kickback.
- ▶ **When the cut is completed, switch off the machine and then pull the saw blade out of the cut only after it has come to a standstill.** In this manner you can avoid kickback and can place down the machine securely.
- ▶ **Use only undamaged saw blades that are in perfect condition.** Bent or dull saw blades can break, negatively influence the cut, or lead to kickback.
- ▶ **Do not brake the saw blade to a stop by applying side pressure after switching off.** The saw blade can be damaged, break or cause kickback.
- ▶ **Use suitable detectors to determine if utility lines are hidden in the work area or call the local utility company for assistance.** Contact with electric lines can lead to fire and electric shock. Damaging a gas line can lead to explosion. Penetrating a water line causes property damage or may cause an electric shock.
- ▶ **Secure the workpiece.** A workpiece clamped with clamping devices or in a vice is held more secure than by hand.
- ▶ **Always wait until the machine has come to a complete stop before placing it down.** The tool insert can jam and lead to loss of control over the power tool.
- ▶ **Before any work on the machine itself, pull the mains plug.**
- ▶ **The saw blade should not be longer than required for the intended cut. Use a narrow saw blade when sawing tight curves.**
- ▶ **Check the tight seating of the saw blade.** A loose saw blade can fall out and lead to injuries.
- ▶ **When ejecting the saw blade, hold the machine in such a manner that no persons or animals can be injured by the ejected saw blade.**
- ▶ **Dusts from materials such as lead-containing coatings, some wood types, minerals and metal can be harmful to one's health and cause allergic reactions, lead to respiratory infections and/or cancer.** Materials containing asbestos may only be worked by specialists.
- As far as possible, use a dust extraction system suitable for the material.
- Provide for good ventilation of the working place.
- It is recommended to wear a P2 filter-class respirator. Observe the relevant regulations in your country for the materials to be worked.
- ▶ **Prevent dust accumulation at the workplace.** Dusts can easily ignite.
- ▶ **Observe correct mains voltage! The voltage of the power source must agree with the voltage specified on the nameplate of the machine. Power tools marked with 230 V can also be operated with 220 V.**
- ▶ To save energy, only switch the power tool on when using it.
- ▶ **The contact protector attached to the casing (see figure 15, page 192) prevents accidental touching of the saw blade during the working procedure and may not be removed.**
- ▶ **Before sawing in wood, particle boards, building materials etc., check for foreign objects, such as nails, screws, etc. and remove them as required.**
- ▶ **Plunge cuts may only be applied to soft materials, such as wood, gypsum board, etc. For plunge cuts, use only short saw blades.**
- ▶ **The sliding shoe can prevent the surface from being scratched. The splinter guard can prevent fraying of the surface while sawing wood. Do not use the splinter guard for mitre cuts.**
- ▶ **Adapt the settings of your power tool to the respective application. For example, reduce the stroke rate and orbital action when cutting metal or for tight curved cuts.**
- ▶ **When working small or thin work pieces, always use a sturdy support or a saw table (accessory).**
- ▶ **In extreme conditions, always use dust extraction as far as possible. Blow out ventilation slots frequently and install a residual current device (RCD).** When working metals, conductive dust can settle in the interior of the power tool. The total insulation of the power tool can be impaired.
- ▶ **Products sold in GB only:** Your product is fitted with a BS 1363/A approved electric plug with internal fuse (ASTA approved to BS 1362). If the plug is not suitable for your socket outlets, it should be cut off and an appropriate plug fitted in its place by an authorised customer service agent. The replacement plug should have the same fuse rating as the original plug. The severed plug must be disposed of to avoid a possible shock hazard and should never be inserted into a mains socket elsewhere.
- ▶ **Products sold in AUS and NZ only:** Use a residual current device (RCD) with a rated residual current of 30 mA or less.

Symbols

The following symbols are important for reading and understanding the operating instructions. Please take note of the symbols and their meaning. The correct interpretation of the symbols will help you to use the machine in a better and safer manner.

Symbol	Meaning
	GST 150 CE: Jigsaw with constant electronic control Grey-marked area: Handle (insulated gripping surface)
	GST 150 BCE: Jigsaw with constant electronic and bow handle Grey-marked area: Handle (insulated gripping surface)
	Read all safety warnings and all instructions
	Before any work on the machine itself, pull the mains plug from the socket outlet
	Wear protective gloves
	Additional information
	Movement direction
	Reaction direction
	Next step of action
	Sawdust blower device
	Extraction
	Mitre/Bevel Angle
	Low stroke rate/speed

Symbol	Meaning
	High stroke rate/speed
	Switching On
	Switching Off
	On/Off switch lock-on
	Prohibited action
	Correct result
	Saw with moderate pressure in order to achieve optimal and precise cutting results.
	When sawing metal, apply coolant/lubricant alongside the cutting line
	Article number (10-digit)
P_1	Rated power input
n_0	Stroke rate at no-load
	Cutting depth, max.
	Wood
	Aluminium
	Metal
	Particle board
	Weight according to EPTA-Procedure 01/2003
	Symbol for protection class II (completely insulated)
L_{pA}	Sound pressure level
L_{wA}	Sound power level
K	Uncertainty
a_h	Vibration total value

Delivery Scope

Jigsaw, splinter guard and extraction kit. Parallel guide, sliding shoe, application tools and other accessories shown or described are not part of the standard delivery scope.

A complete overview of accessories can be found in our accessories program.

12 | English

Intended Use

The machine is intended for making separating cuts and cut-outs in wood, plastic, metal, ceramic plates and rubber while resting firmly on the workpiece. It is suitable for straight and curved cuts with mitre angles to 45°. The saw blade recommendations are to be observed.

Technical Data

The technical data of the machine are listed in the table on page 182.
The values given are valid for a nominal voltage [U] of 230 V. For different voltages and models for specific countries, these values can vary.

Declaration of Conformity

We declare under our sole responsibility that the product described under "Technical Data" is in conformity with the following standards or standardization documents: EN 60745 according to the provisions of the directives 2011/65/EU, 2004/108/EC, 2006/42/EC.

Technical file (2006/42/EC) at:
Robert Bosch GmbH, PT/ETM9,
D-70745 Leinfelden-Echterdingen

Henk Becker	Helmut Heinzelmann
Executive Vice President	Head of Product Certification
Engineering	PT/ETM9

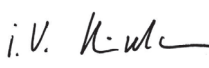
PPA.
 i. V. 

Robert Bosch GmbH, Power Tools Division
D-70745 Leinfelden-Echterdingen
Leinfelden, 18.03.2014

Noise/Vibration Information

The measured values of the machine are listed in the table on page 182.

Noise and vibrational values (vector sum of three directions) determined according to EN 60745.









The vibration level given in this information sheet has been measured in accordance with a standardised test given in EN 60745 and may be used to compare one tool with another. It may be used for a preliminary assessment of exposure. The declared vibration emission level represents the main applications of the tool. However if the tool is used for different applications, with different accessories or insertion tools or is poorly maintained, the vibration emission may differ. This may significantly increase the exposure level over the total working period.











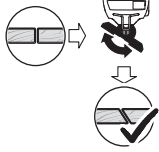

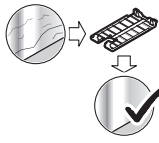
An estimation of the level of exposure to vibration should also take into account the times when the tool is switched off or when it is running but not actually doing the job. This may significantly reduce the exposure level over the total working period.

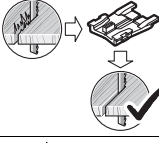
Identify additional safety measures to protect the operator from the effects of vibration such as: maintain the tool and the accessories, keep the hands warm, organisation of work patterns.

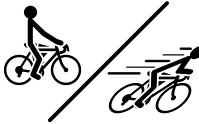
Mounting and Operation

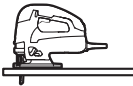
The following table indicates the action objectives for mounting and operation of the power tool. The instructions for each action objective are shown aside. Depending on the type of application, various instruction combinations are required. Observe the safety instructions.

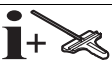
Action	Figure	Please observe	Page
Inserting the Saw Blade 	1		183
Ejecting the Saw Blade 	2		183
Switching on the sawdust blower device 	3		183
Connecting the dust extraction 	4		184-185

Action	Figure	Please observe	Page
Adjusting the Cutting Angle			185 – 186
Mounting the sliding shoe			187
Mounting the splinter guard			187
Orbital Action Settings			188
Adjusting the stroke rate preselection			188
Switching On and Off			189
Guide the power tool toward the workpiece only when switched on			190
Lubrication when cutting metal			190
Plunge Cutting			190 – 191
Mounting and use of the parallel guide			191 – 192
Selecting Accessories	-		194 – 196

Maintenance and Cleaning

- **For safe and proper working, always keep the machine and the ventilation slots as well as the tool holder clean.**

If the replacement of the supply cord is necessary, this has to be done by Bosch or an authorized Bosch service agent in order to avoid a safety hazard.

Clean the saw blade holder regularly. For this, remove the saw blade from the machine and lightly tap out the machine on a level surface.

Regularly spray penetrating oil onto the saw blade holder (see figure 16, page 193).

Check the guide roller regularly. If worn, it must be replaced through an authorised Bosch after-sales service agent.

Lubricate the guide roller occasionally with a drop of oil (see figure 17, page 193).

14 | Français

After-sales Service and Application Service

Our after-sales service responds to your questions concerning maintenance and repair of your product as well as spare parts. Exploded views and information on spare parts can also be found under:

www.bosch-pt.com

Bosch's application service team will gladly answer questions concerning our products and their accessories.

In all correspondence and spare parts order, please always include the 10-digit article number given on the type plate of the machine.

Great Britain

Robert Bosch Ltd. (B.S.C.)
P.O. Box 98
Broadwater Park
North Orbital Road
Denham
Uxbridge
UB 9 5HJ

At www.bosch-pt.co.uk you can order spare parts or arrange the collection of a product in need of servicing or repair.

Tel. Service: (0844) 7360109

E-Mail: bschservicecentre@bosch.com

Ireland

Origo Ltd.
Unit 23 Magna Drive
Magna Business Park
City West
Dublin 24

Tel. Service: (01) 4666700

Fax: (01) 4666888

Australia, New Zealand and Pacific Islands

Robert Bosch Australia Pty. Ltd.
Power Tools
Locked Bag 66
Clayton South VIC 3169
Customer Contact Center
Inside Australia:
Phone: (01300) 307044
Fax: (01300) 307045
Inside New Zealand:
Phone: (0800) 543353
Fax: (0800) 428570
Outside AU and NZ:
Phone: +61 3 95415555
www.bosch.com.au

Republic of South Africa

Customer service

Hotline: (011) 6519600

Gauteng – BSC Service Centre

35 Roper Street, New Centre
Johannesburg
Tel.: (011) 4939375
Fax: (011) 4930126
E-Mail: bsctools@icon.co.za

KZN – BSC Service Centre

Unit E, Almar Centre
143 Crompton Street
Pinetown
Tel.: (031) 7012120
Fax: (031) 7012446
E-Mail: bsc.dur@za.bosch.com

Western Cape – BSC Service Centre

Democracy Way, Prosperity Park
Milnerton
Tel.: (021) 5512577
Fax: (021) 5513223
E-Mail: bsc@zsd.co.za

Bosch Headquarters

Midrand, Gauteng
Tel.: (011) 6519600
Fax: (011) 6519880
E-Mail: rbsa-hq.pts@za.bosch.com

Disposal

The machine, accessories and packaging should be sorted for environmental-friendly recycling.

Do not dispose of power tools into household waste!

Only for EC countries:



According to the European Guideline 2012/19/EU for Waste Electrical and Electronic Equipment and its implementation into national right, power tools that are no longer usable must be collected separately and disposed of in an environmentally correct manner.

Subject to change without notice.

Français

Avertissements de sécurité généraux pour l'outil

⚠ AVERTISSEMENT







Lire tous les avertissements de sécurité et toutes les instructions.

Ne pas suivre les avertissements et instructions peut donner lieu à un choc électrique, un incendie et/ou une blessure sérieuse.

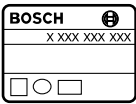
Conservation tous les avertissements et toutes les instructions pour pouvoir s'y reporter ultérieurement.

Le terme « outil » dans les avertissements fait référence à votre outil électrique alimenté par le secteur (avec cordon d'alimentation) ou votre outil fonctionnant sur batterie (sans cordon d'alimentation).

182 |

		GST 150 CE	GST 150 BCE
			
		3 601 E12 0..	3 601 E13 0..
P_1	W	780	780
n_0	min^{-1}	500–3100	500–3100
	mm	150	150
	mm	20	20
	mm	10	10
	kg	2,6	2,7
L_{pA}	dB(A)	84	83
L_{wA}	dB(A)	95	94
K	dB	3	3
a_h 	m/s^2	8	7,5
a_h 	m/s^2	7	4
K	m/s^2	1,5	1,5

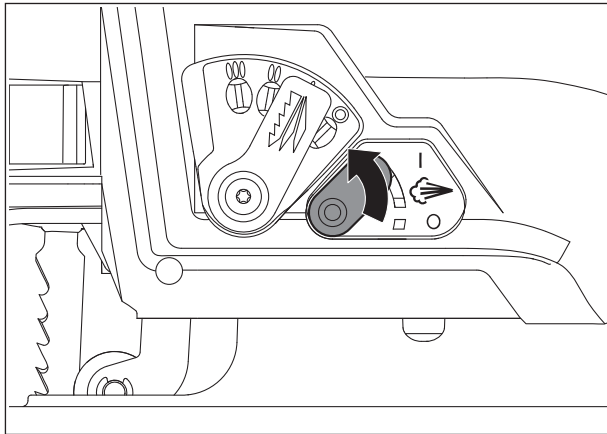
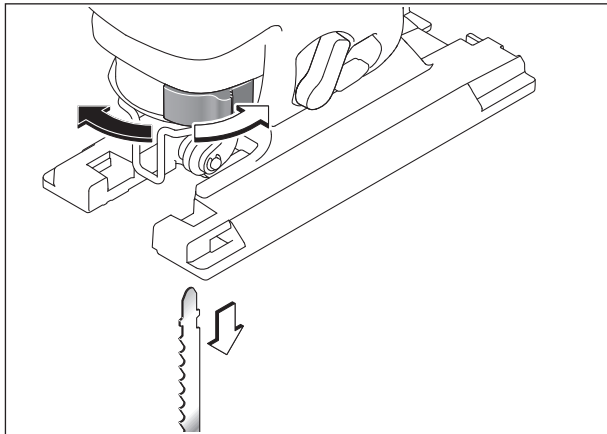
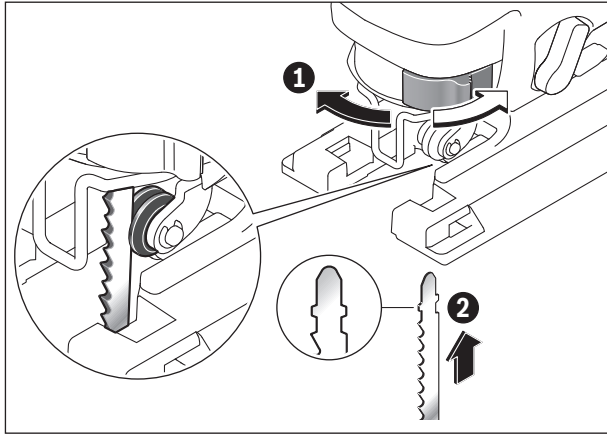
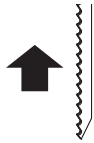

4

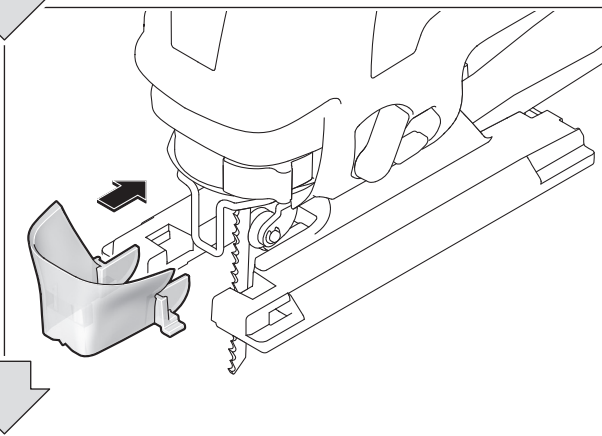
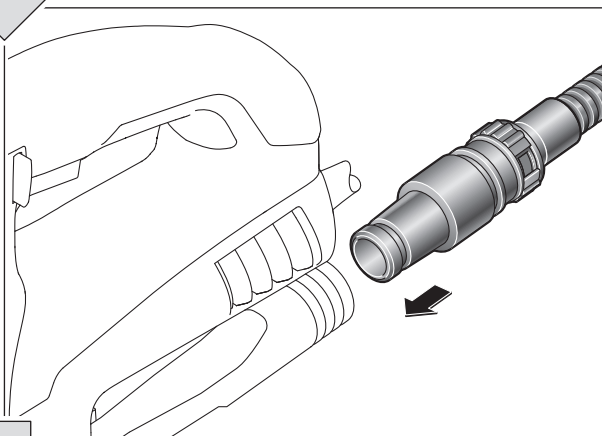
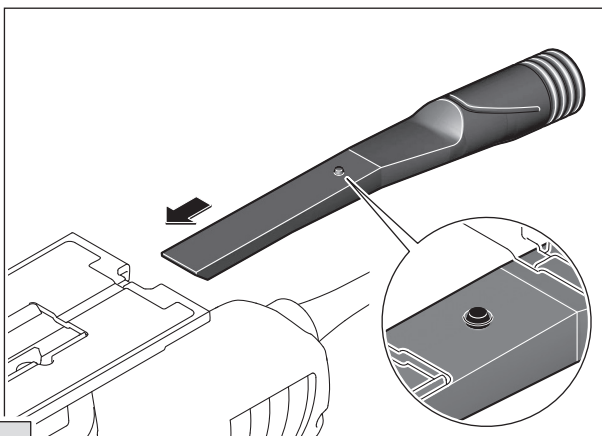
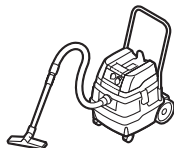

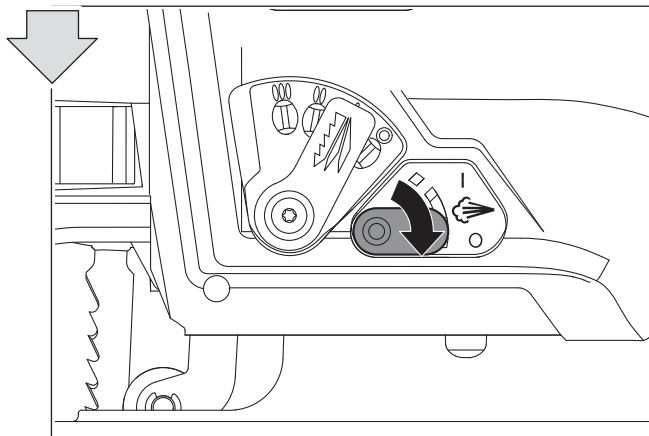

5

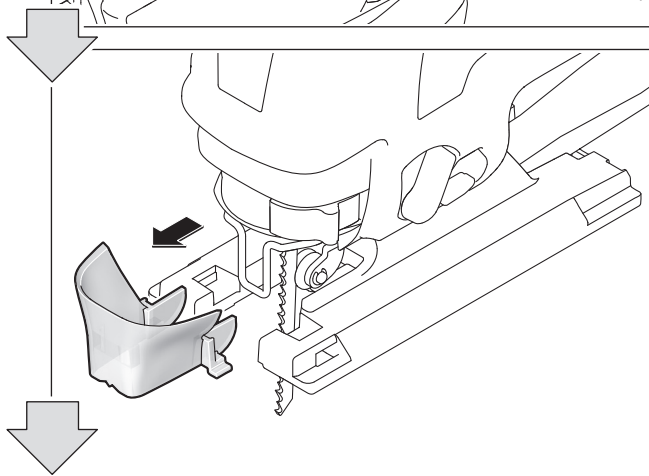
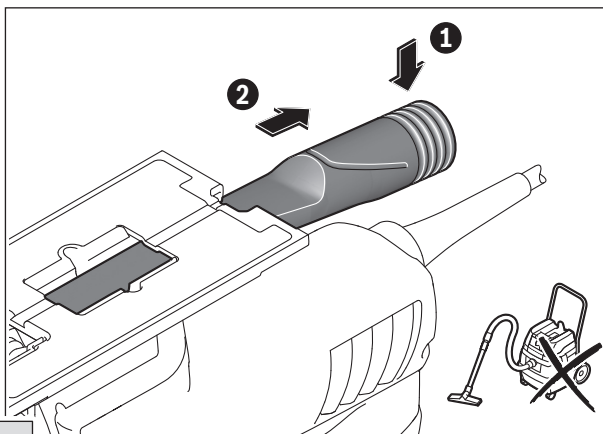
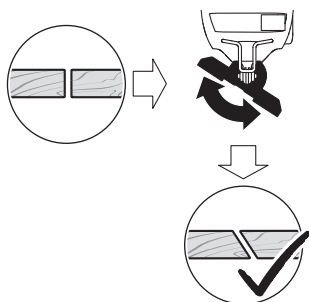

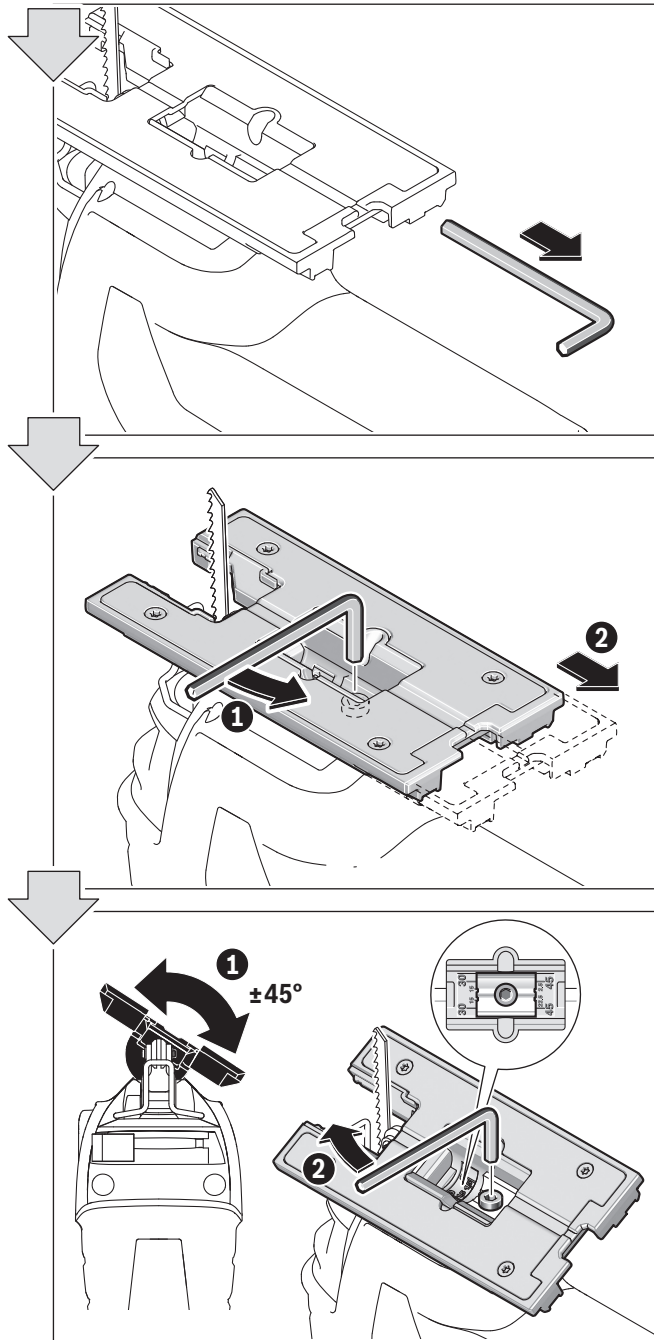

6

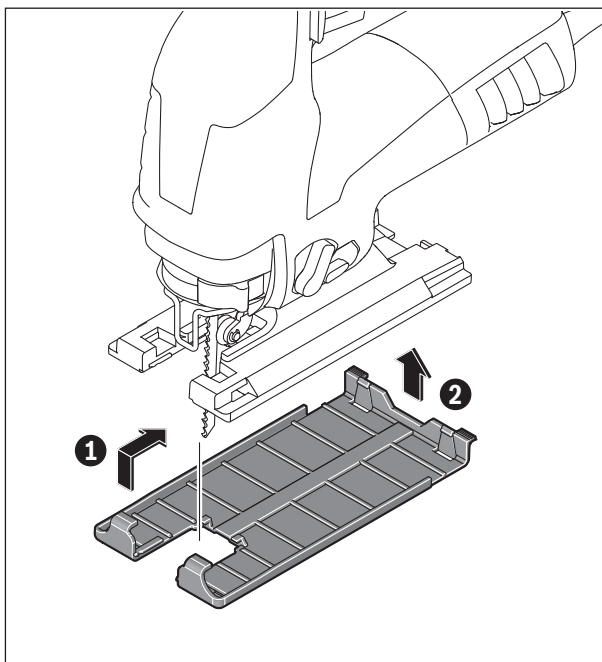
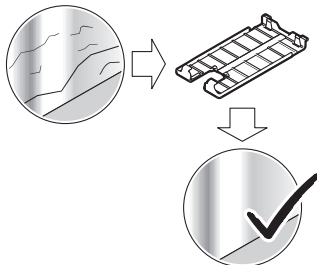

7

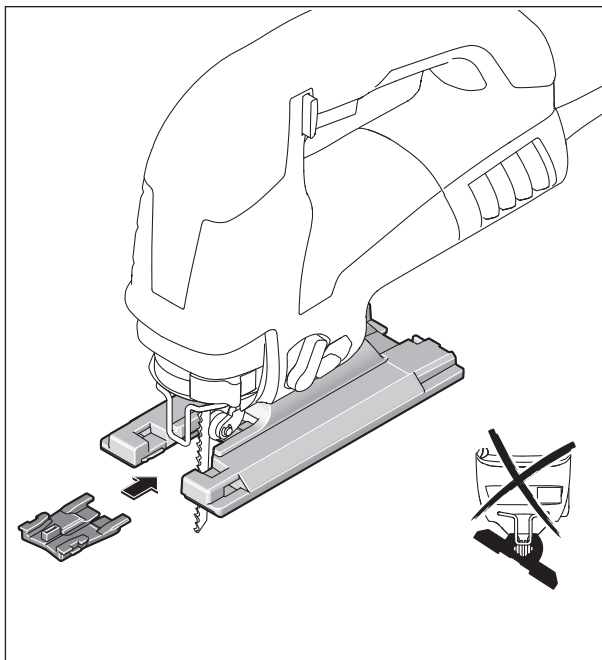
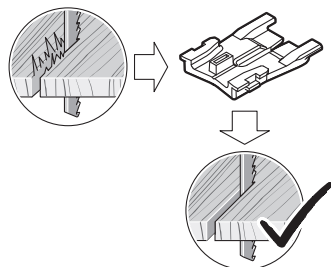

8

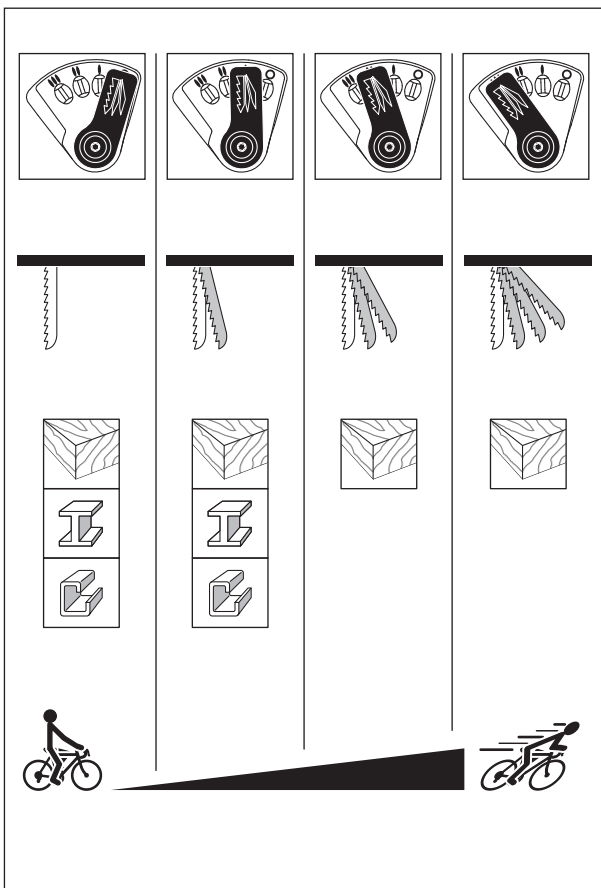
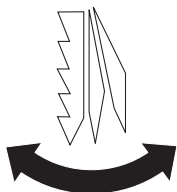

9

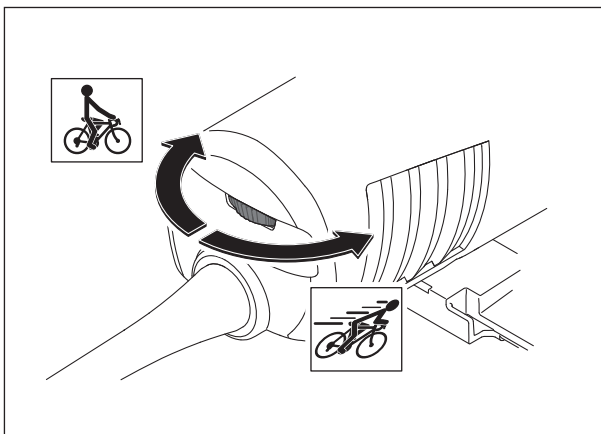

10

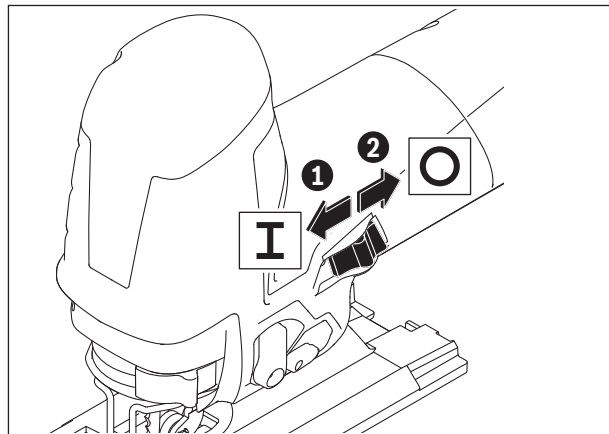
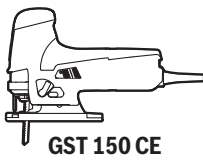
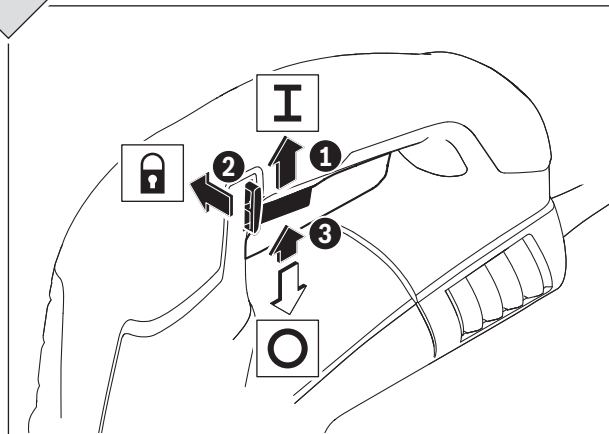
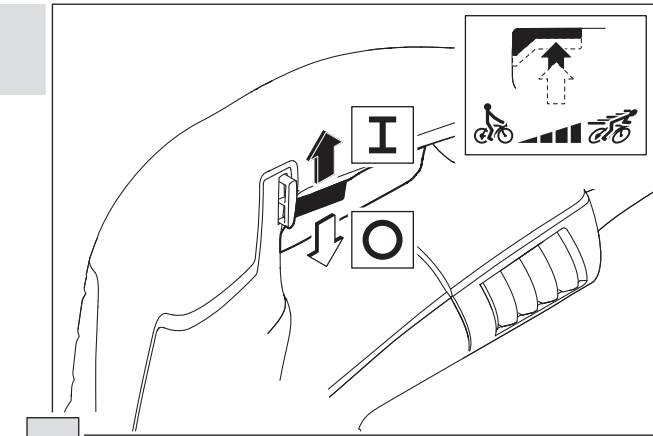
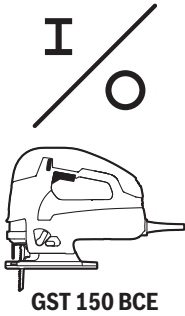

190 |

11

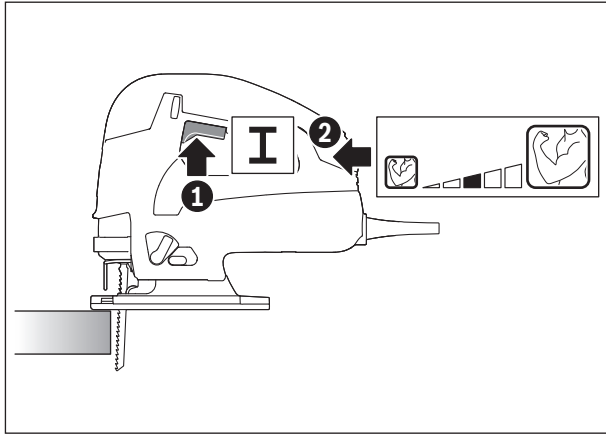
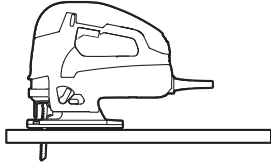

12

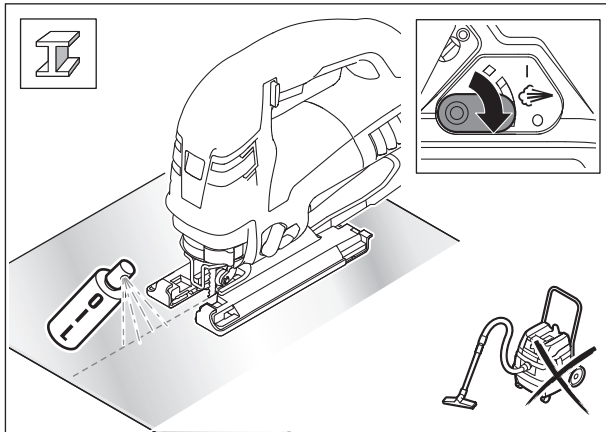

13

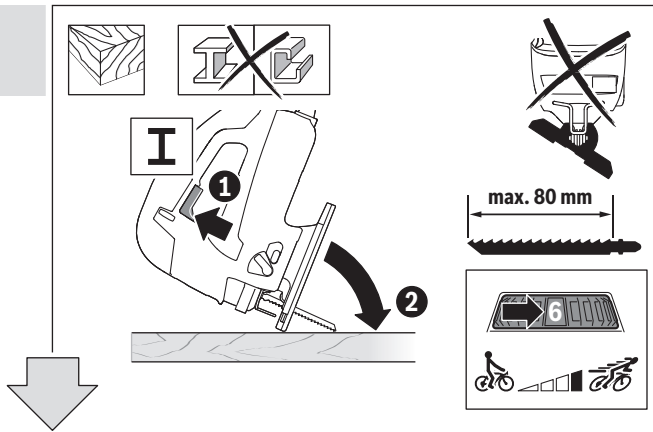
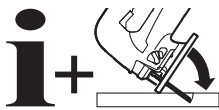

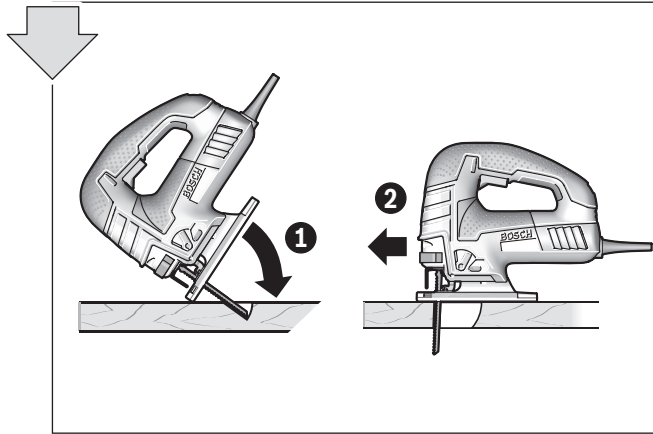

14

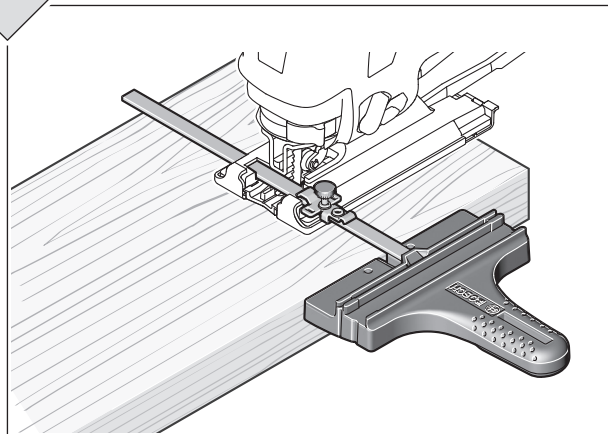
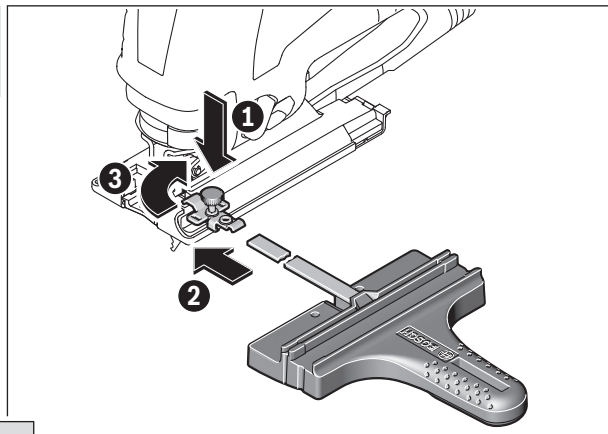
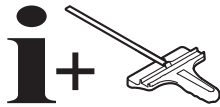

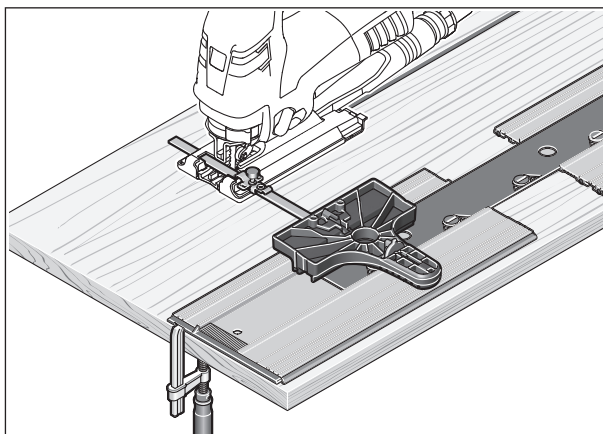
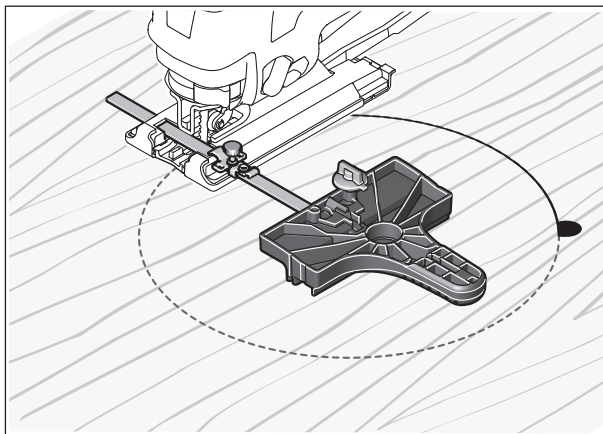

15

i+

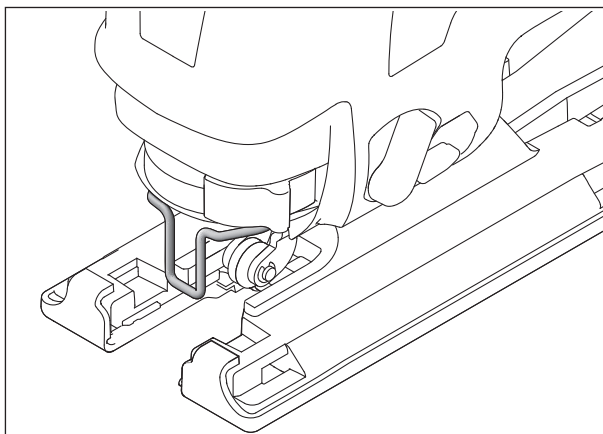

16

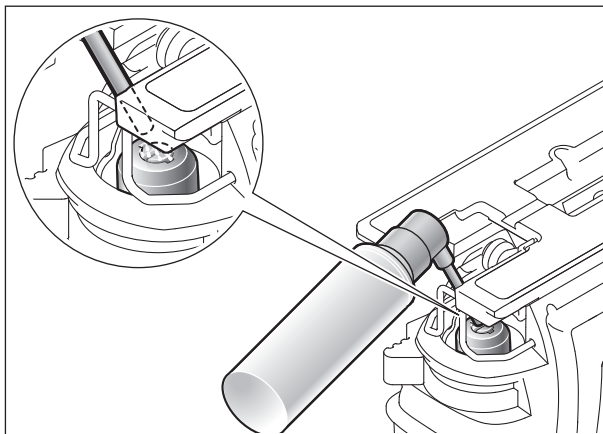

17

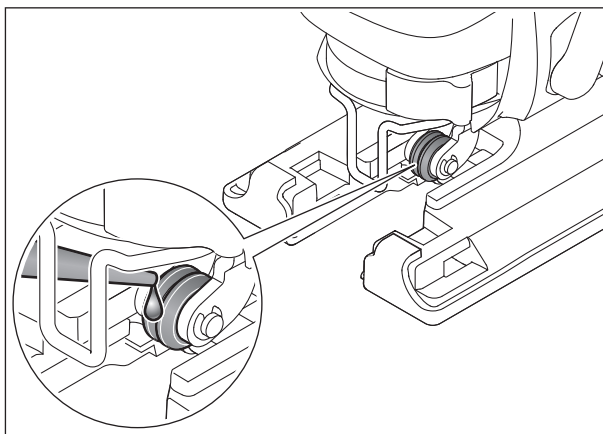



speed for Wood	T 144 D	<i>fast</i> CUT			±5-50mm
speed for Wood	T 244 D	<i>fast</i> CUT			±5-50mm
precision for Wood	T 144 DP				±5-50mm
clean for Wood	T 101 B	<i>clean</i> CUT			± 3-30mm < 30mm
extra-clean for Wood	T 308 B	<i>extra clean</i> CUT			±5-50mm ±5-50mm
extra-clean for HardWood	T 308 BF	<i>extra clean</i> CUT			±5-50mm ±5-50mm ±5-50mm Multiplex
special for Laminate	T 101 BIF	<i>clean</i> CUT			±1,5-15mm
basic for Metal	T 118 B				±2,5-6mm
PROGRESSOR for Metal	T 123 X	<i>fast</i> CUT			±1,5-10mm < 30mm < 30mm ALU
special for Alu	T 127 D	<i>fast</i> CUT			< 30mm < 30mm < 30mm ± 3-15mm ALU
PROGRESSOR for Wood and Metal	T 345 XF	<i>fast</i> CUT			< 65mm < 65mm < 65mm

