

Erbauer®

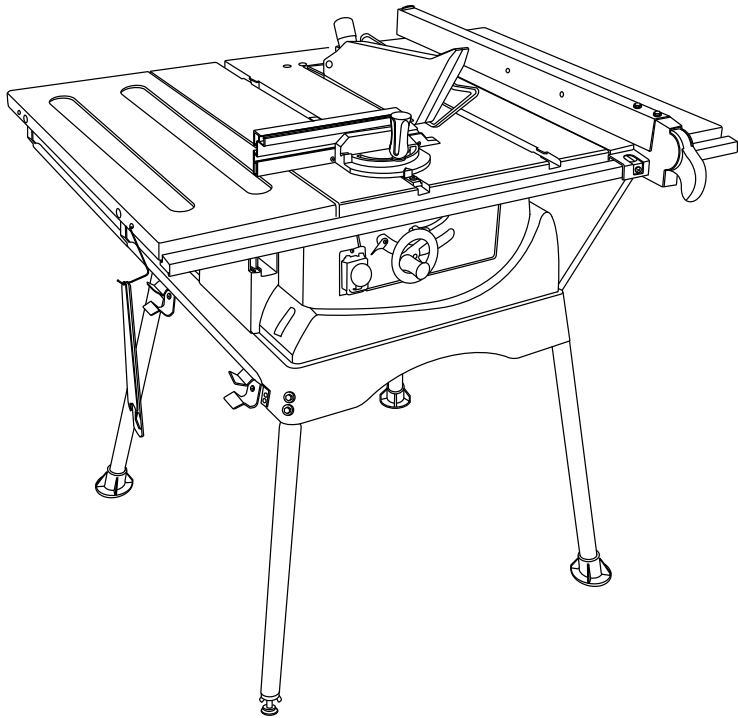

ERB2504SE

2 WARRANTY
YEARS

ERBAUER 250MM TABLE SAW

ERBAUER 250MM TABLE SAW

Erbauer®

Congratulations on your purchase of a quality power tool from Erbauer (UK) Ltd. This product should give you reliable service but your peace of mind this Erbauer power tool does carry a 24-month guarantee, the terms of which are detailed below.

If this product develops a fault within the guarantee period contact your retailer.

Please retain this handbook in case you need to refer to safety, care or guarantee information in the future.

GUARANTEE

This **Erbauer** product carries a guarantee of 24 months. If your product develops a fault within this period, you should, in the first instance contact the retailer where the item was purchased.

This guarantee specifically excludes losses caused due to:

- Fair wear and tear
- Misuse or abuse
- Lack of routine maintenance
- Failure of consumable items (such as batteries)
- Accidental damage
- Cosmetic damage
- Failure to follow manufacture's guidelines
- Loss of use of the goods

This guarantee does not affect your statutory rights. This guarantee is only valid in the UK.

For further technical advice and spare parts, Please contact the customer helpline number on 0845 607 6380 quoting your Erbauer model number.

SAFETY INSTRUCTIONS



WARNING! Read all instructions. Failure to follow all instructions listed below may result in electric shock, fire and/or serious injury.

SAVE THESE INSTRUCTIONS

SAVE THESE INSTRUCTIONS

1. Work area

a. Keep work area clean and well lit. Cluttered and dark areas invite accidents.

b. Do not operate power tools in explosive atmospheres, such as in the presence of flammable liquids, gases or dust. Power tools create sparks which may ignite the dust or fumes.

c. Keep children and bystanders away while operating a power tool. Distractions can cause you to lose control.

2. Electrical safety

a. Power tool plugs must match the outlet. Never modify the plug in any way. Do not use any adapter plugs with earthed (grounded) power tools. Unmodified plugs and matching outlets will reduce risk of electric shock.

b. Avoid body contact with earthed or grounded surfaces such as pipes, radiators, ranges and refrigerators. There is an increased risk of electric shock if your body is earthed or grounded.

c. Do not expose power tools to rain or wet conditions. Water entering a power tool will increase the risk of electric shock.

d. Do not abuse the cord. Never use the cord for carrying, pulling or unplugging the power tool. Keep cord away from heat, oil, sharp edges or moving parts. Damaged or entangled cords increase the risk of electric shock.

e. When operating a power tool outdoors, use an extension cord suitable for outdoor use. Use of a cord suitable for outdoor use reduces the risk of electric shock.

3. Personal safety

a. Stay alert, watch what you are doing and use common sense when operating a power tool. Do not use a power tool while you are tired or under the influence of drugs, alcohol or medication. A moment of inattention while operating power tools may result in serious personal injury.

b. Use safety equipment. Always wear eye protection. Safety equipment such as dust mask, non-skid safety shoes, hard hat, or hearing protection used for appropriate conditions will reduce personal injuries.

c. Avoid accidental starting. Ensure the switch is in the off-position before plugging in. Carrying power tools with your finger on the switch or plugging in power tools that have the switch on invites accidents.

d. Remove any adjusting key or spanner before turning the power tool on. A spanner or a key left attached to a rotating part of the power tool may result in personal injury.

e. Do not overreach. Keep proper footing and balance at all times. This enables better control of the power tool in unexpected situations.

ERBAUER 250MM TABLE SAW

f. Dress properly. Do not wear loose clothing or jewellery. Keep your hair, clothing and gloves away from moving parts. Loose clothes, jewellery or long hair can be caught in moving parts.

g. If devices are provided for the connection of dust extraction and collection facilities, ensure these are connected and properly used. Use of these devices can reduce dust related hazards.

4. Power tool use and care

a. Do not force the power tool. Use the correct power tool for your application.

The correct power tool will do the job better and safer at the rate for which it was designed.

b. Do not use the power tool if the switch does not turn it on and off.

Any power tool that cannot be controlled with the switch is dangerous and must be repaired.

c. Disconnect the plug from the power source before making any adjustments, changing accessories, or storing power tools. Such preventive safety measures reduce the risk of starting the power tool accidentally.

d. Store idle power tools out of the reach of children and do not allow persons unfamiliar with the power tool or these instructions to operate the power tool. Power tools are dangerous in the hands of untrained users.

e. Maintain power tools. Check for misalignment or binding of moving parts, breakage of parts and any other condition that may affect the power tools operation. If damaged, have the power tool repaired before use. Many accidents are caused by poorly maintained power tools.

f. Keep cutting tools sharp and clean. Properly maintained cutting tools with sharp cutting edges are less likely to bind and are easier to control.

g. Use the power tool, accessories and tool bits etc., in accordance with these instructions and in the manner intended for the particular type of power tool, taking into account the working conditions and the work to be performed. Use of the power tool for operations different from intended could result in a hazardous situation.

5. Service

a. Have your power tool serviced by a qualified repair person using only identical replacement parts.

This will ensure that the safety of the power tool is maintained.

HEALTH ADVICE



Warning! When drilling, sanding, sawing or grinding, dust particles will be produced. In some instances, depending on the materials you are working with, this dust can be particularly harmful to you (e.g. lead from old gloss paint). You are advised to consider the risks associated with the materials you are working with and to reduce the risk of exposure. You should:

- Work in a well-ventilated area.
- Work with approved safety equipment, such as those dust masks that are specially designed to filter microscopic particles.

6. Safety precautions

a. Do not use saw blades which are damaged or deformed.

b. Replace table insert when worn.

c. Use only saw blades recommended by the manufacturer and which are the exact bore and diameter required for this machine. When changing the saw blade beware that the width of the groove cut of the saw blade shall not less than and thickness of the body of the saw blade shall not be more than the thickness of the riving blade.

d. Take care that the selection of the saw blade is suitable for the material to be cut.

e. Wear suitable personal protective equipment when necessary, this could include:

- **Hearing protection to reduce the risk of induced hearing loss.**

- **Respiratory protection to reduce the risk of inhalation of harmful dust.**

- **Wear gloves when handling saw blades and rough material.** Saw blade shall carried in a holder whenever practicable.

i. Connect circular saws to a dust-collecting device when sawing wood. The operator shall be informed of the factors that influence exposure of dust e.g. type of material being machined and importance of local extraction (capture or source) and proper adjustment of hoods/baffles/chutes.

j. Do not use high speed steel (HS) blades.

k. The push-stick or push block should always be stored with the machine when not in use.

7. Safe operation

a. Use push-sticks or push blocks to feed the workpiece past the saw blade.

b. Use correct adjustment of the riving blade.

c. Use correct adjustment of the upper saw blade guard.

d. Saws shall not be used for slotting (stopped groove).

e. Use only saw blades for which the maximum possible speed is not less than the maximum spindle speed of the tool and the material to be cut.

f. When transporting the machine use only transportation devices and do never use guards for handling or transportation.

g. During transportation the upper part of the saw blade should be covered , for example by the guard.

ADDITIONAL SAFETY INSTRUCTIONS FOR YOUR TABLE SAW



WARNING: Before using your table saw, it is critical that you read and understand these safety rules. Failure to follow these rules could result in serious injury or damage to the table saw.

- 1. ALWAYS USE SAW BLADE GUARD** for every operation
- 2. ALWAYS HOLD WORK FIRMLY** against the mitre gauge or rip fence.
- 3. ALWAYS USE** a push stick, especially when ripping narrow stock.
- 4. NEVER PERFORM ANY OPERATION FREEHAND, which means using only your hands to support or guide the workpiece. Always use either the fence or the mitre gauge to position and guide the work.**



WARNING: FREEHAND CUTTING IS THE MAJOR CAUSE OF KICKBACK AND FINGER/HAND AMPUTATIONS.

- 5. NEVER STAND** or have any part of your body in line with the path of the saw blade. Keep your hands out of the saw blade path.
- 6. NEVER REACH** behind or over the cutting tool for any reason.
- 7. REMOVE** the rip fence when crosscutting.
- 8. DO NOT USE** a molding head with this saw.
- 9. FEED WORK INTO THE BLADE** against the direction of rotation only.
- 10. NEVER** use the rip fence as a cut-off gauge when crosscutting.
- 11. NEVER ATTEMPT TO FREE A STALLED SAW BLADE** without first turning the saw **OFF**. Turn power switch **OFF** immediately to prevent motor damage.
- 12. PROVIDE ADEQUATE SUPPORT** to the rear and the sides of the saw table for long or wide workpieces.
- 13. AVOID AWKWARD OPERATIONS** and hand positions where a sudden slip could cause your hand to move into the saw blade.
- 14. NEVER USE SOLVENTS** to clean plastic parts. Solvents could possibly dissolve or otherwise damage the material. Only a soft damp cloth should be used to clean plastic parts.

15. NEVER CUT METALS or materials that may make hazardous dust.

16. ALWAYS USE IN A WELL-VENTILATED AREA. Remove sawdust frequently.

Clean out sawdust from the interior of the saw to prevent a potential fire hazard. Attach a vacuum to the dust port for additional sawdust removal.

17. NEVER LEAVE THE SAW RUNNING UNATTENDED. Do not leave the saw until the blade comes to a complete stop.

VIBRATION

The European Physical Agents (Vibration) Directive has been brought in to help reduce hand arm vibration syndrome injuries to power tool users. The directive requires power tool manufacturers and suppliers to provide indicative vibration test results to enable users to make informed decisions as to the period of time a power tool can be used safely on a daily basis and the choice of tool.

Further Advice can be found at www.hse.gov.uk

Vibration total values (triax vector sum) determined according to EN 61029:	
Work mode description 1 (Vibration for Table Saw)	Vibration emission value $a_h = 3.35 \text{ m/s}^2$ Uncertainty $K = 1.5 \text{ m/s}^2$

The declared vibration emission value should be used as a minimum level should be used with the current guidance on vibration. Calculating the actual period of the actual period off use can be difficult and the HSE website has further information.

The declared vibration emission been measured in accordance with a standardised test stated above and may be used to compare one tool with another.

The declared vibration emission value may also be used in a preliminary assessment of exposure.

 **WARNING:** The operation of any table saw can result in foreign objects being thrown into your eyes, which can result in severe eye damage. Before beginning power tool operation, always wear safety goggles or safety glasses with side shield and a full face shield when needed.

 **Warning:** If any parts are missing, do not operate your table saw until the missing parts are replaced. failure to follow this rule could result in serious personal injury.

 **Caution:** Do not let familiarity with your table saw makes you careless. Remember that a careless fraction of a second is sufficient to cause severe injury.

Double insulation: 

The tool is double insulated. This means that all the external metal parts are electrically insulated from the mains power supply. This is done by placing insulation barriers between the electrical and mechanical components making it unnecessary for the tool to be earthed.

Important note

Be sure the supply is the same as the voltage given on the rating plate. The tool is fitted with a two-core cable and plug. Remove the mains plug from socket before carrying out any adjustment or servicing.

SYMBOLS



Read the manual



Warning



Wear gloves



Wear dust mask, eye & ear protection



Symbol for transportation position



Conforms to relevant safety standards

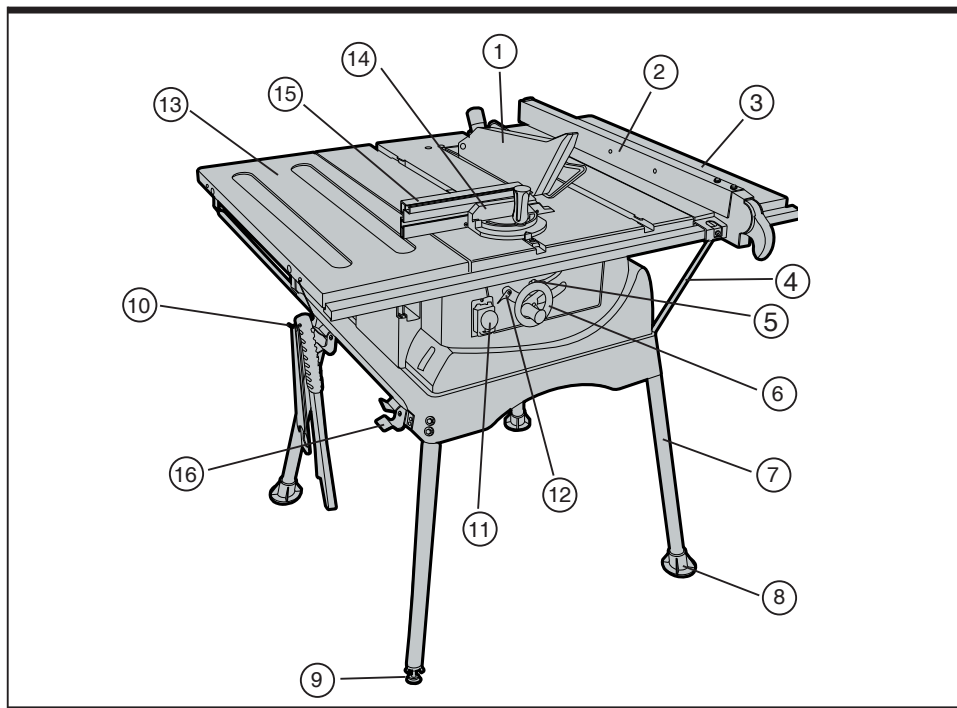

Fig 1

-
- 1. UPPER BLADE GUARD**

 - 2. RIP FENCE**

 - 3. RIGHT SIDE TABLE EXTENSION**

 - 4. EXTENSION SUPPORT**

 - 5. BLADE BEVEL LOCK KNOB**

 - 6. BLADE TILTING HANDWHEEL**

 - 7. STAND ASSEMBLY**

 - 8. FOOT PAD**

 - 9. ADJUSTABLE STAND PAD**

 - 10. PUSH STICK STORAGE**

 - 11. NO-VOLT-RELEASE (NVR) SWITCH**

 - 12. BEVEL ANGLE POINTER & SCALE**

 - 13. LEFT SIDE TABLE EXTENSION**

 - 14. MITRE GAUGE**

 - 15. AUXILIARY FENCE**

 - 16. FENCE STORAGE**
-

ERBAUER 250MM TABLE SAW

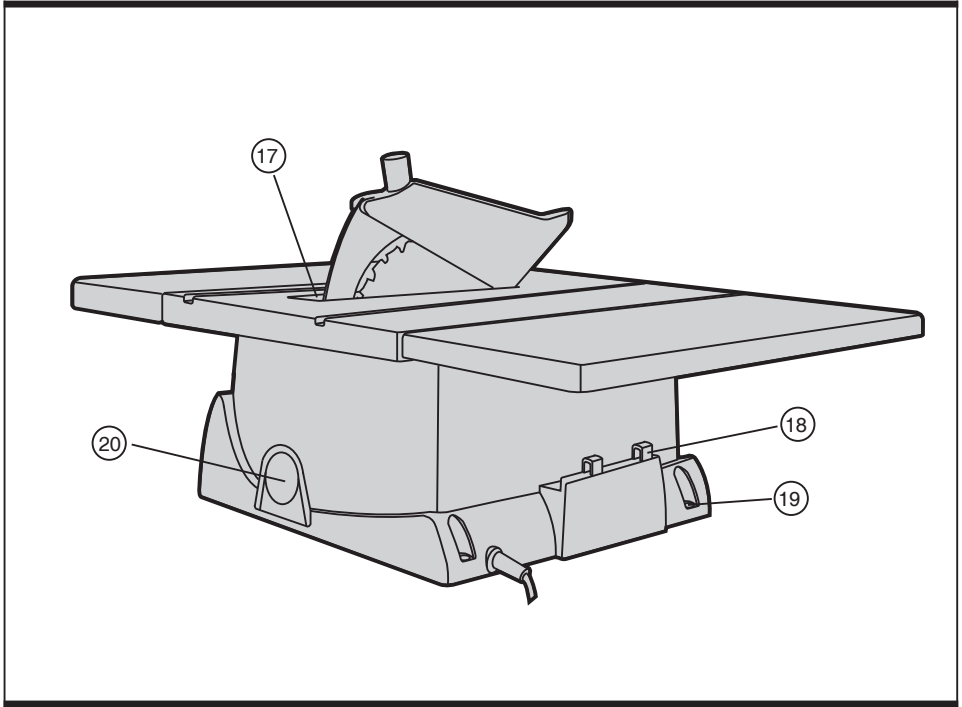

Fig 2

17. TABLE INSERT

18. MITRE GAUGE STORAGE

19. MOUNTING HOLE

20. DUST PORT

TECHNICAL DATA

Motor

Volts:	230V-50Hz
Power input:	1700W (S6, 25%, 10min)
No-load speed:	4800min ⁻¹
Double insulation:	<input type="checkbox"/>
Overload protection:	YES

SAW

Table size with extension:	970mm X 670mm
Table extension:	left, right
Rip capacity with extension:	130mm R x 185mm L
Blade size:	Outside Dia. 250 mm Bore Dia. 30 mm T 1.8 mm
Rip scale	YES
Rip fence	YES
Mitre gauge	YES
Maximum cut depth @ 90°	73mm
Maximum cut depth @ 45°	63mm
Machine weight:	26.5 kg

NOISE DATA

Sound pressure level:	95.4 dB (A)
Sound power level:	108.4 dB (A)

ERBAUER 250MM TABLE SAW

ACCESSORIES

Table saw assembly	1 pc
Blade guard assembly	1 pc
Riving blade hardware bag	1 pc
Rip fence assembly	1 pc
Blade	1 pc
Blade spanner	2 pc
Push stick	1 pc
Mitre gauge assembly	1 pc
Push stick storage	1 pc
Handwheel assembly	1 pc
Auxiliary fence assembly	1pc
Auxiliary fence hardware bag	1 pc
Table side extension	2 pc
Left side table extension support	2 pc
Right side table extension support	2 pc
Table side extension hardware bag	1 pc
Dust port adapter	1 pc

STAND

Leg	4 pc
Foot pad	3 pc
Fence storage clip hardware bag	1 pc
Stand hardware bag	1 pc

ASSEMBLY INSTRUCTIONS

Warning: For your own safety, never connect the plug to power source outlet until all assembly steps are completed and you have read and understood the safety and operational instructions.

1. Installing table side extension

- 1) Place protective corrugated cardboard or old blanket on floor to protect the saw table surface.
- 2) Place the saw up-side down on the protective material.
- 3) Place the right table extension next to the saw table, aligning the mounting holes (1).
- 4) Insert the bolts (4) through the mounting holes and attach the nuts (2).
- 5) Place a straight edge (7) or combination square in front of the saw table and table extension.
- 6) Adjust the nut (2) until the extension is aligned with the saw table. Tighten.
- 7) Place the extension supports (3) to the right table extension and secure them on the stand with bolts (5) and nuts (6).
- 8) Repeat these procedures for the left extension table (See fig. 1).

Description	Size	QTY
bolts (4)	M6*1.0-12	4
nuts (2)	M6*1.0 T=5	4
bolt (5)	M6*1.0-12	8
nut (6)	M6*1.0 T=6	8

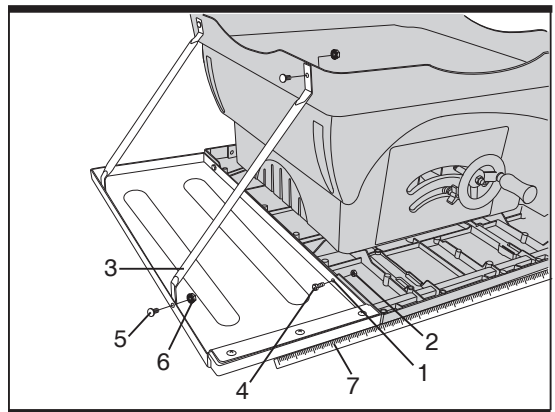

Fig 1

2. Stand assembly

- 1) Attach four legs (1) to stand base assembly (2) using hex bolts (3) washers (4) and nuts (5).

Note:

Do not tighten bolts until stand is properly aligned (see step #3 before tightening).

- 2) Insert foot pad (6) into bottom of leg. Repeat for the other two legs as shown.

- 3) Carefully set the saw in its upright position on a clean level surface and adjust the adjustable foot pad (7), so all legs are contacting the floor and are at similar angles to the floor, and tighten all bolts (See fig. 2).

Note: To avoid rocking, tighten all bolts.

- 4) Thread the long screw (8) through the hole (9) on foot pad (10) to fasten the stand (See fig. 2-1).

Note: The tools to mount this saw is not supplied with the saw.

Description	Size	QTY
hex bolt (3)	M6*1.0-45	8
washer (4)	φ6*18-1.5	16
nut (5)	M6*1.0 T=4	8

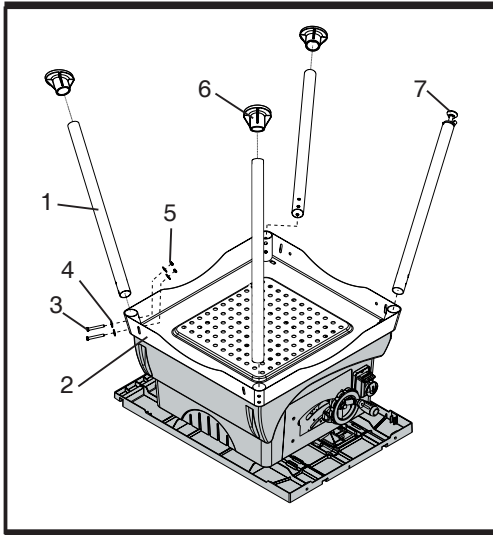

Fig 2

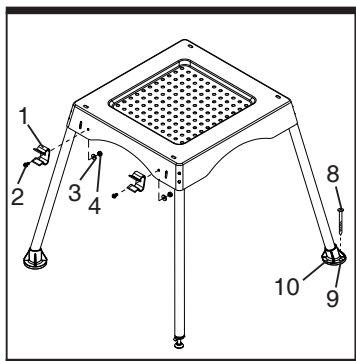

Fig 2-1

3. Installing the rip fence storage

1) Attach the fence storage clips (1) to the left of the stand assembly with screws (2) washers (3) and nuts (4) for rip fence storage (See fig. 2-1).

Description	Size	QTY
screws (2)	M6*1.0-12	2
washers (3)	φ6*18-1.5	2
nut (4)	M6*1.0 T=4	2

4. Installing and changing the blade



Warning:

- To avoid injury from accidental starting, always turn the switch off ("0") and remove the power plug from the power source before changing the blades.
- The riving blade must have constant clearance along its length and not be in contact with the blade.
- Keep wearing the gloves during removing and installing the blade.
- Ensure that the saw blade bore is exactly the correct size for this machine and the diameter does not exceed 250mm.

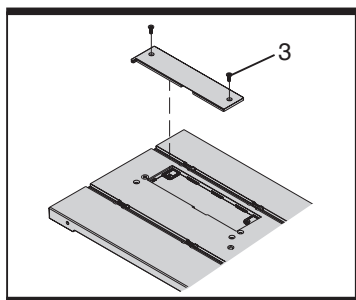

Fig 3

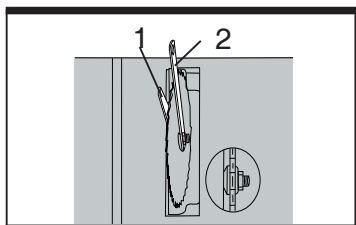

Fig 4

- 1) Loosen the screws (3) on the table insert by a screwdriver and remove the table insert (See fig. 3).
- 2) Raise the saw blade to its maximum height.
- 3) Use the supplied open end spanner (1) to keep the arbor from turning and place the supplied box-end spanner (2) on the arbor nut, and turn counterclockwise to loosen the arbor nut (See fig. 4).

- 4) Remove the arbor nut and outer flange.
- 5) Replace the saw blade. Make sure the teeth of the blade point down at the front of the table.
- 6) Assemble the arbor flange and arbor nut back to the saw arbor and tighten the arbor nut by turning the supplied box-end spanner (2) clockwise (to the rear of the saw table).
- 7) Replace the table insert and retighten the two screws.

5. Installing the riving blade

- 1) Rise the blade to its highest position by turning the handwheel and tilt the blade to 45° bevel angle.
- 2) Loosen the screws on the table insert and remove the table insert.
- 3) Place the bolts (3), and flat washers (4) on the riving blade (6) and the riving blade bracket (5).
- 4) Tighten the bolts (3) (See fig. 5).
- 5) Replace the table insert and tighten the screw.



Warning:

- The riving blade thickness of 2.5 mm. Make sure the blade and riving blade are aligned on the same line. If not, adjust the riving blade by loosening the bolts. It should be less than 5 mm at all positions (See fig. 5).
- Keep wearing the gloves during removing and installing the blade.

Description	Size	QTY
bolts (3)	M6*1.0-16	2
flat washers (4)	1/4*3/4-1/16	2

6. Blade guard assembly

- 1) Place the blade guard on the riving blade and secure it with the bolt (1), flat washer (2), and nut (3) (See fig. 6).

Description	Size	QTY
bolt (1)	M6*1.0-40	1
flat washer (2)	φ6*13-1	1
nut (3)	M6*1.0	1

7. Aligning the riving blade

- 1) If the blade and riving blade are not correctly aligned:
 - Remove the table insert by removing the screws.
 - Remove the blade guard by removing the bolt, flat washer and nut that lock the guard in place.
 - Loosen the two bolts (3) from the riving blade bracket (5).
- 2) Insert the supplied spacers (7) between the riving blade (6) and bracket (5).
- 3) Retighten the two mounting bolts (3) securely.
- 4) Replace the blade guard assembly using the bolt, flat washer and nut.
- 5) Check the riving blade and blade alignment again at both 90° and 45°.
- 6) Add or remove the spacers until the alignment is correct.
- 7) Replace the table insert. (See fig. 7).

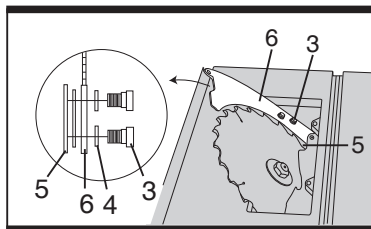

Fig 5

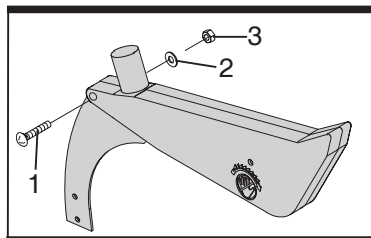

Fig 6

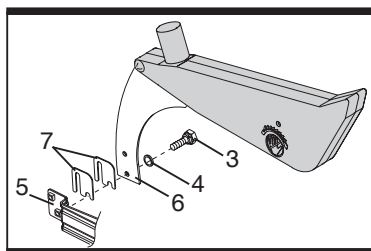

Fig 7

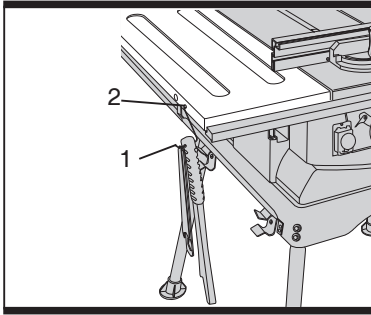

Fig 8

Note: This tool is accurately adjusted before shipping from the factory. Check the following accuracy and readjust them if necessary in order to obtain the best results in operation.

8. Installing the push stick and blade spanner storage

1) Attach the hook (1) into the hole (2) of the side table for push stick and blade spanner storage (See fig. 8).

9. Using auxiliary fence on the rip fence

A auxiliary fence should be used when ripping material such as thin paneling to prevent the material from catching between the bottom of the fence and the table. When performing some special cutting operations, you can add a auxiliary fence (3) to the either side of the rip fence (4).

- 1) Attach the square nuts to the rip fence with the clamp handles (1) through the washers (5) and holes in the rip fence.
- 2) Slide the auxiliary fence (3) to the square nuts (2).
- 3) Tighten the clamp handles (See fig. 9).

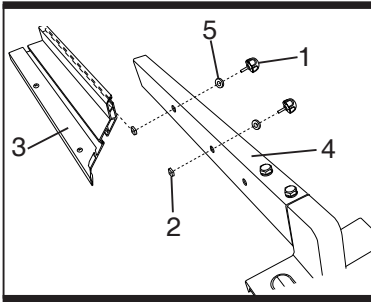

Fig 9

10. Using auxiliary fence on the mitre gauge

When performing some special cutting operations, you can add a auxiliary fence (2) to the mitre gauge (1).

- 1) Attach the square nuts to the mitre gauge with the washers (3) and screws (4).
- 2) Slide the auxiliary fence (2) to the square nuts (5).
- 3) Tighten the screws (See fig. 10).

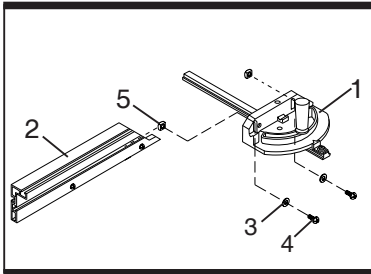

Fig 10

11. Installing the rip fence and mitre gauge

- 1) Lift upward on the rip fence handle (1) so the rear holding clamp (2) is fully extended.
- 2) Place the rip fence on the saw table, lowering the front of the fence onto the table first.
- 3) Push down on the fence handle (1) to lock
- 4) Place the mitre gauge (3) in the groove (4) on the table top. (See fig. 11).

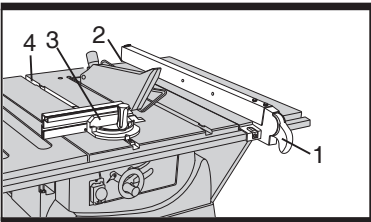

Fig 11

ADJUSTMENT INSTRUCTIONS

1. Adjusting the blade parallel to the mitre gauge groove



Warning: This adjustment must be correct or kickback could result and accurate cuts cannot be made.

- 1) Raise the blade to its highest position and set it to 0° bevel angle.
- 2) Select a tooth on the saw blade which is bent to the right. Mark that tooth with a pencil or permanent marker.
- 3) Place the mitre gauge (1) in the right hand groove (2) on the table top. Set the mitre gauge to 90° and tighten the gauge handle to lock it in that position.
- 4) Rotate the blade to bring the marked tooth in the front and about 13 mm above the table top. Place the bar of square (3) flat against the mitre gauge and move the bar toward the saw blade until it just touches the tip of the marked saw blade tooth (See fig. 12).
- 5) Without disturbing the bar clamped to the mitre gauge (1), move the mitre gauge to the centre of the saw blade. Rotate the blade so the marked tooth is at the rear and about 13 mm above the table top.
- 6) Slide the mitre gauge rearward until the clamped bar is closest to the tip of the marked tooth (See fig. 13).
- 7) If the bar just touches the tooth when the gauge was in the front position, it should touch the tooth in the rear position.
- 8) If the front and rear clearance are not identical, remove the mitre gauge, loosen four screws (1) and carefully grasp the saw blade. Make necessary correction until measurements taken at the front and rear are identical. Tighten the four screws (1) (See fig. 14).

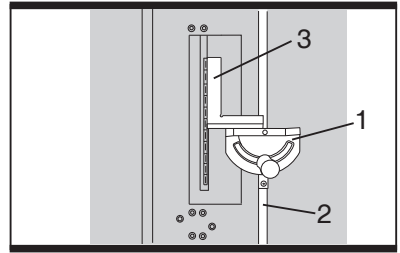

Fig 12

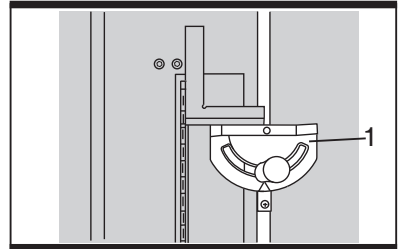

Fig 13

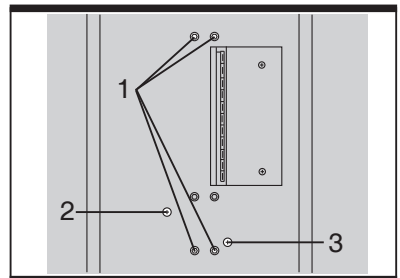

Fig 14

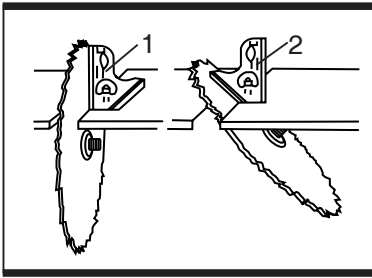

Fig 15

2. Adjusting 90° positive stop of blade

- 1) Raise the saw blade to its maximum height.
- 2) Loosen the saw blade tilt lock handle and move the saw blade tilting mechanism to the left until it hits against the stopper. Then tighten the saw blade tilt lock handle.
- 3) Use a square (1) to check the saw blade is at 90° (See fig. 15).
- 4) If the saw blade is not at 90°, loosen the saw blade tilt lock handle. Adjust the screws (2) a few turns and move the saw blade tilting mechanism until the blade is at 90° to the table (See fig. 14).
- 5) Tighten the saw blade tilt lock handle after adjustment.
- 6) Loosen the screw of the tilt pointer and set the pointer to 0°.

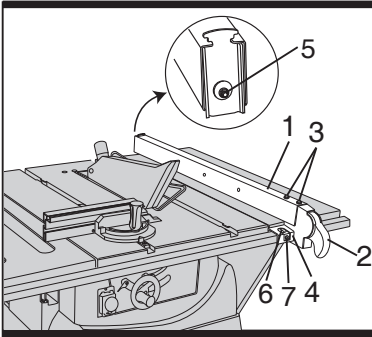

Fig 16

3. Adjusting 45° positive stop of blade

- 1) Raise the saw blade to its maximum height.
- 2) Loosen the saw blade tilt lock handle and move the saw blade tilting mechanism to the right until it hits against the stopper. Then tighten the saw blade tilt lock handle.
- 3) Use a 45° gauge (2) to check the saw blade is at 45° (See fig. 15).
- 4) If the saw blade is not at 45°, loosen the saw blade tilt lock handle. Adjust the screws (3) a few turns and move the saw blade tilting mechanism until the blade is at 45° to the table (See fig. 14).
- 5) Tighten the saw blade tilt lock handle after adjustment.
- 6) Loosen the screw of the tilt pointer and set the pointer to 45°.

4. Adjusting rip fence

- 1) The fence (1) is moved by lifting the handle (2) and sliding the fence to the desired location. Pushing down on the handle locks the fence in place.
- 2) Position the fence on the right side of the table, along the edge of the mitre gauge groove.
- 3) Lock the fence handle. The fence should be parallel with the mitre gauge groove.
- 4) If adjustment is needed in order to make the fence parallel to the groove, follow these steps:
 - Loosen the two bolts (3), and lift the handle (2).
 - Hold the fence bracket (4) firmly against the front of the saw table. Move the far end of the fence until it is parallel with the mitre gauge groove.
 - Push the handle down to lock it, and tighten both screws.

5) If fence is loose when the handle is in the locked (down) position, follow these steps:

- Lift the handle (2) and turn the adjusting nut (5) clockwise until the rear clamp is snug. Do not turn the adjusting screw more than 1/4 turn at a time.
- Over-tightening the adjusting screw could bend the rear clamping lever, which may cause the fence to come out of alignment (See fig. 16).

5. Adjusting the pointer of rip fence

1) The rip fence indicator (6) points to the measurement scale. The scale shows the distance from the side of the fence closest to the blade.

2) Measure the actual distance with a ruler. If there is a difference between the measurement and the indicator, adjust the indicator (6).

3) Loosen the screw (7), and slide the indicator to the correct measurement on the scale.

Tighten the screw, and remeasure with the ruler (See fig. 16).

6. Adjusting the mitre gauge

1) To adjust pointer 90° setting, loosen the clamp handle (1) and place a square (2) against both the saw blade (3) and mitre gauge (4). The pointer (5) should indicate 90° on the mitre gauge.

2) If the pointer does not point to 90° on the mitre gauge, tighten the clamp handle, loosen the pointer screw (6) on the bar, adjust the pointer to the 90° position and retighten the pointer screw (See fig. 17).

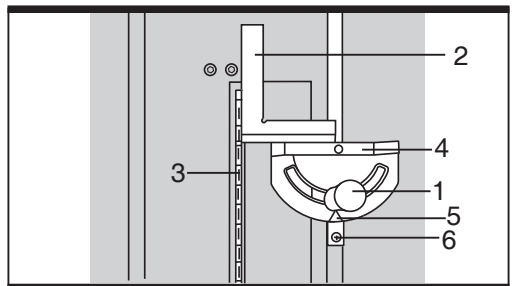

Fig 17

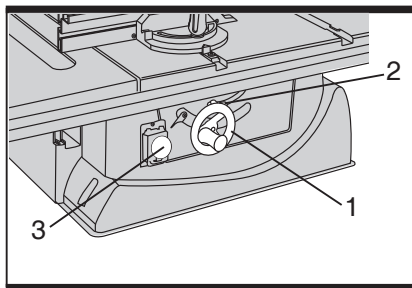

Fig 18

OPERATION INSTRUCTIONS

Warning: Before using your table saw be sure to read the instruction manual carefully.

Operating instructions

1. Switches of the table saw

The main switch (3), No Volt Release (NVR) switch, is on the front of saw base. Press "1" to turn on the power; press "O" to turn off the power (See fig. 18).

Warning: Never connect the plug to the power source outlet until all installations and adjustments are completed and you have read and understood the safety and operational instructions.

2. Raising and lowering the saw blade

Warning: Never operate while saw blade rotating.

- 1) To raise the saw blade, rotate the handwheel (1) anticlockwise.
- 2) To lower the saw blade, rotate the handwheel (1) clockwise.

Note: The saw blade height is recommended about 3.2 mm above the top of the workpiece.

3. Tilting the saw blade

Warning: Always lock the saw blade tilt lock handle during operations.

Loosen the saw blade tilt lock handle (2), move the hand wheel until the saw blade is at the desired angle and tighten the saw blade tilt lock handle (See fig. 18).

4. Moving the rip fence

Note:

- The rip fence can be used on either side of the saw blade.
- The pointer on the rip fence indicates the distance between the saw blade and rip fence.
- To move the rip fence, loosen the clamp handle while pressing the fence bracket against the table surface and set the desired distance from the saw blade, retighten the clamp handle.

5. Operating the mitre gauge

Note:

- The mitre gauge can be used on either side of the saw blade.
- Because the mitre gauge groove is a T-type slot, to install the mitre gauge, insert the gauge bar from the end of the groove.
- To set the mitre cut angle, loosen the clamp handle, turn the mitre gauge to the desired angle, retighten the clamp handle.

6. Ripping

Note:

- Generally ripping is cutting with the grain.
- Do not perform ripping “free hand”. Use the rip fence for ripping and remove the mitre gauge from the table.



Warning:

- Before ripping, confirm the following items:
 - a) Rip fence is securely fixed and parallel to the saw blade.
 - b) Riving blade is properly aligned with the saw blade.
 - c) The workpiece must have a straight edge against the rip fence and must not be warped, twisted or bowed.
- Keep both hands away from the saw blade and away from the path of the saw blade.

- 1) Adjust the saw blade height so it is about 3.2 mm above the top of the workpiece.
- 2) Hold the workpiece flat on the table and against the rip fence. Keep the workpiece about 25 mm away from the saw blade.
- 3) Turn on the switch and allow the saw blade to come up to speed.
- 4) Keep the workpiece against the table and rip fence, slowly feed the workpiece rearward all the way through the saw blade. Continuously push the workpiece until it passes the blade guard and clears the rear of the table.
- 5) When ripping long boards or large panels, always use an adequate support.
- 6) When the width of rip is more than 150 mm, feed the workpiece with one or both hands continuously until it is beyond the saw blade and riving blade (See fig. 19).

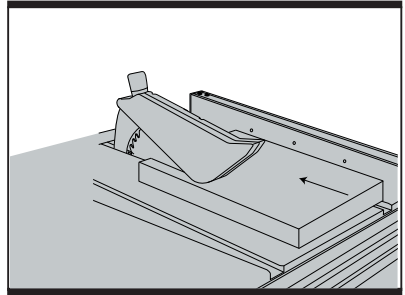

Fig 19

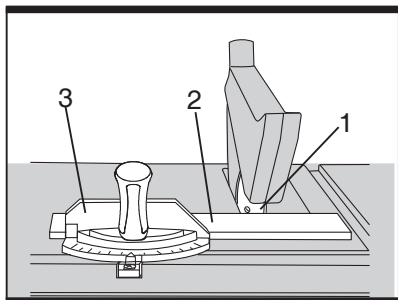

Fig 20

Warning: Never operate while saw blade rotating.

7) When the width of rip 50 mm to 150 mm wide, use the supplied push stick to feed the workpiece.

8) When perform bevel ripping, only work with the work piece and rip fence on the right side of the saw blade.

7. Crosscutting

Note:

- Generally cross cutting is cutting across the grain.
- Do not perform cross cutting “free hand” . Use the mitre gauge for cross cutting and remove the rip fence from the table.

Warning:

- Before cross cutting, confirm the following items:
 - a) Riving blade is properly aligned with the saw blade.
 - b) The workpiece must have a straight edge against the mitre gauge and must not be warped, twisted or bowed.
- Keep both hands away from the saw blade and away from the path of the saw blade.

1) Adjust the saw blade (1) height so it is about 3.2 mm above the top of the workpiece.

2) Hold the workpiece flat on the table and against the mitre gauge. Keep the workpiece about 25 mm away from the saw blade.

3) Turn on the switch and allow the saw blade (1) to come up to full speed.

4) Keep the workpiece (2) against the table and mitre gauge (3), slowly feed the workpiece rearward all the way through the saw blade. Continuously push the workpiece until it is clear of the blade guard and it falls off the rear of the table.

5) When performing bevel cross cutting, only work with the workpiece and mitre gauge on the right side of the saw blade (See fig. 20).

8. Bevel crosscutting

This cutting operation is the same as crosscutting except the blade is at bevel angle other than 0°.

Warning: Always work to the right side of the blade during this type of cut. The mitre gauge (3) must be in the right side groove (2) because the bevel angle may cause the blade guard to interfere with the cut if used on the left side groove.

- 1) Adjust the blade (1) to the desired angle, and tighten the blade bevel lock knob.
- 2) Tighten mitre lock handle at 90°.
- 3) Hold workpiece firmly against the face of the mitre gauge (3) throughout the cutting operation (See fig. 21).

Note: When tilting the blade to 45°, the mitre gauge handle will hit the blade guard.

9. Compound mitre crosscutting

This sawing operation is combining a mitre angle with a bevel angle.

Warning: Always work to the right side of the blade during this type of cut. The mitre gauge (3) must be in the right side groove because the bevel angle may cause the blade guard to interfere with the cut if used on the left side groove. When tilting the workpiece to 45° and push it toward the blade, the blade guard may hit the blade. To avoid injury, stop the work at that time.

- 1) Set the mitre gauge (3) to the desired angle.
- 2) Place the mitre gauge (3) in the right side groove (2) of the table.
- 3) Set the blade (1) bevel to the desired bevel angle and tighten the blade bevel lock knob.
- 4) Hold workpiece firmly against the face of the mitre gauge (3) throughout the cutting operation (See fig. 22).

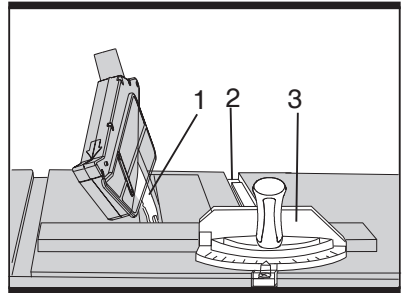

Fig 21

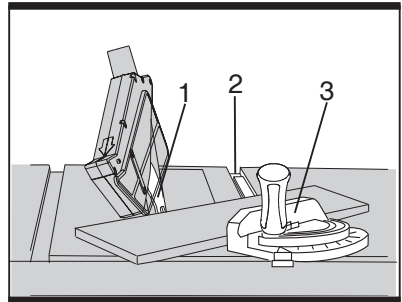

Fig 22

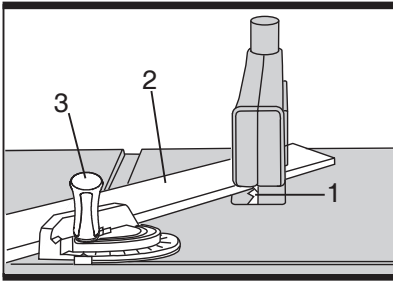

Fig 23

10. Mitre cuts

This sawing operation is the same as crosscutting except the mitre gauge is locked at an angle other than 90°.

- 1) Set the blade (1) to 0° bevel angle and tighten the blade bevel lock knob.
- 2) Set the mitre gauge (3) at the desired mitre angle and lock in position by tightening the mitre gauge locking handle.
- 3) Hold the workpiece (2) firmly against the face of the mitre gauge throughout the cutting operation (See fig. 23).

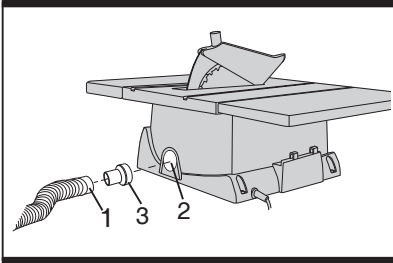

Fig 24

11. Using the dust port



Warning:

- To prevent fire hazard, clean and remove sawdust from under the saw frequently.
- To prevent sawdust build up inside the saw housing, attach a vacuum hose (1) to the dust port (2) at the rear of the table saw. DO NOT operate the saw with the hose in place unless the vacuum is turned on (See fig. 24).

Note: A 58-37 mm dust port adapter (3) is provided for your convenience.

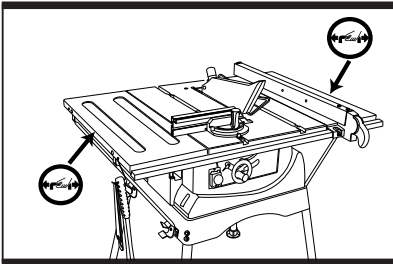

Fig 25

12. Transportation the machine

- 1) Symbol for transportation position (See fig. 25).



Warning:

When transporting the machine use only transportation devices and do never use guards for handling or transportation.

MAINTENANCE

GENERAL MAINTENANCE

Warning: Before maintaining or lubricating the saw, turn switch off, remove the switch key, and unplug the saw.

- 1) Clean out all sawdust that has accumulated inside the saw cabinet and the motor.
- 2) Polish the saw table with an automotive wax to keep it clean and to make it easier to slide the workpiece.
- 3) Clean cutting blades with pitch and gum remover.
- 4) Immediately replace a worn, cut, or damaged power cord.

Warning: All electrical or mechanical repairs should be attempted only by a trained repair technician. Contact the nearest Service Centre for service. Use only identical replacement parts. Any other parts may create a hazard.

- 5) Use liquid dish washing detergent and water to clean all plastic parts.

Note: Certain cleaning chemicals can damage plastic parts.

- 6) Avoid use of the following cleaning chemicals or solvents: ammonia and household detergents containing ammonia.

Blade raising and tilting mechanism

After each five full hours of operation, the blade raising mechanism and tilting mechanism should be checked for looseness, binding, or other abnormalities. With the saw disconnected from the power source, turn the saw upside down and alternately pull upward and downward on the motor unit. Observe any movement of the motor mounting mechanism. Adjust looseness or play in the blade raising screw (1) as follows:

- 1) Using a 14 mm spanner, loosen the check-nut (2).
- 2) Adjust nut (3) until it is finger-tight against the bracket (4), and then back off the nut (3) 1/6 turn.
- 3) Tighten nut (2) with a second 14 mm spanner, while holding nut (3) with the first spanner in place. Maximum allowable play of screw rod (1) is 0.16 in. (4 mm) (See fig. 26).

You can place a small amount of dry lubricant on bevel angle adjustment rod also. This rod (1) must be kept clean and free of sawdust, gum, pitch, and other contaminants for smooth operation.

If excessive looseness is observed in any parts of the blade raising mechanism or tilting mechanism, take the complete unit to a Service Centre.

LUBRICATION

All motor bearings are permanently lubricated at the factory and require no additional lubrication.

On all mechanical parts of your table saw where a pivot or threaded rod are present, lubricate using graphite or silicone. These dry lubricants will not hold sawdust as would oil or grease.

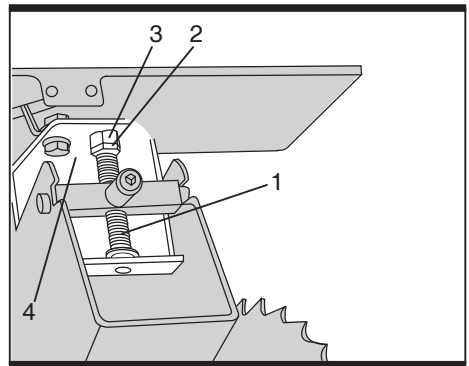

Fig 26

ENVIRONMENTAL PROTECTION



Waste electrical products should not be disposed of with household waste. Please recycle where facilities exist. For further information visit www.recycle-more.co.uk.

PLUG REPLACEMENT

The fuse in the main plug of your power tool should always be replaced with one of identical rating.

Check the voltage given on your power tool matches the supply voltage.

The power tool is supplied with a fitted plug, however if you should need to fit a new plug follows the instruction below.

IMPORTANT

The wire in the mains lead are coloured in accordance with the following code:

Blue ---Neutral

Brown ---Live

The wire that is coloured **blue** must be connected to the terminal that is marked with the letter **N**. The wire that is coloured **brown** must be connected to the terminal that is marked with the letter **L**.

A 13AMP (BS1363 or BS1363/A) plug must be used and a 13 AMP fuse must be fitted.

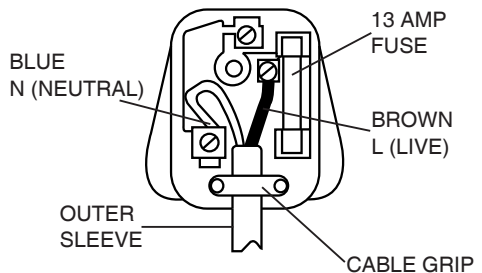

Erbauer®

Declaration of Conformity

We, Importer

Erbauer (UK) Ltd.

BA22 8RT

Declare that the product

ERB2504SE

ERBAUER 250MM TABLE SAW

Complies with the essential health and safety requirements of the following directives:

2004/108/EC – EMC Directive

2006/95/EC – Low Voltage Directive

98/37/EC – Machinery Directive

2002/95/EC – Restrictions of the Use of Certain Hazardous Substances
in Electrical and Electronic Equipment

Standards and technical specifications referred to:

EN 55014-1:2000/+A1:2001/+A2:2002

EN 55014-2:1997/+A1:2001

EN 61000-3-2:2006

EN 61000-3-11:1995/+A1:2001/+A2:2005

EN 61029-2-9:2002

EN 61029-1:2000

Authorised Signatory

Date: 2/14/07

Signature: P. Harries

Name: Peter Harries

Erbauer (UK) Ltd

Quality Manager



2007

ERBAUER 250MM TABLE SAW

Erbauer®

ERBAUER 250MM TABLE SAW