

# EC DECLARATION OF CONFORMITY

The manufacturer of the product covered by this Declaration is.



NAP Brands Ltd.  
Napier House, Unit 7, Corunna Court,  
Warwick, United Kingdom CV34 5HQ

The manufacturer hereby declares that the machine as detailed in this declaration fulfils all the relevant provisions of the Machinery Directive and other appropriate directives as detailed below.

The manufacture further declares that the machine as detailed in this declaration, where applicable, fulfils the relevant provisions of the essential health and safety requirements.

## The Directives covered by this Declaration are as detailed below

98/37/EEC The Machinery Directive.  
2006/95/EC. Low Voltage Equipment Directive.  
2004/108/EC. Electromagnetic Compatibility Directive,  
93/68/EC. The CE Marking Directive.  
2002/95/EC. The Restriction of the Use of certain Hazardous Substances in Electrical Equipment (RoHS) Directive  
2002/96/EC as amended by 2003/108/EC The Waste Electrical and Electronic Equipment (WEEE) Directive.

## And is in conformity with the applicable requirements of the following documents

??

### Product Details:

**Description:** Arc Welder

**Model No:** IM-ARC140

**Brand Name:** Impax

### Name and address of technical documentation holder.

The technical documentation required to demonstrate that the product meets the requirements of directive has been compiled and is available for inspection by the relevant enforcement authorities.

Signed:  Print: Mark Shannon

Senior Quality Control Manager.

NAP Brands Ltd.

Napier House, Unit 7, Corunna Court, Warwick, United Kingdom CV34 5HQ



Date: 04.09.2013

After sales support: Tel: 0844 264 2485 Website: [www.impaxpowertools.com](http://www.impaxpowertools.com)



# 140A ARC WELDER

IM-ARC140



Always Read Instruction Manual  
Retain for Future Reference

# CERTIFICATE OF GUARANTEE

---

This product is guaranteed for a period of 1 Year, with effect from the date of purchase and applies only to the original purchaser. This guarantee only applies to defects arising from, defective materials and or faulty workmanship that become evident during the guarantee period only and does not include consumable items. The manufacturer will repair or replace the product at their discretion subject to the following. That the product has been used in accordance with the guidelines as detailed in the product manual and that it has not been subjected to misuse, abuse or used for a purpose for which it was not intended. That it has not been taken apart or tampered with in any way whatsoever or has been serviced by unauthorised persons or has been used for hire purposes. Transit damage is excluded from this guarantee, for such damage the transport company is responsible. Claims made under this guarantee must be made in the first instance, directly to the retailer within the guarantee period. Only under exceptional circumstances should the product be returned to the manufacturer. In this case it shall be the consumer's responsibility to return the product at their cost ensuring that the product is adequately packed to prevent transit damage and must be accompanied with a brief description of the fault and a copy of the receipt or other proof of purchase. The manufacturer shall not be liable for any special, exemplary, direct, indirect, incidental, or consequential loss or damage under this guarantee. This guarantee is in addition to and does not affect any rights, which the consumer may have by virtue of the Sale of Goods Act 1973 as amended 1975 and 1999.

## INTRODUCTION

---

Thankyou for purchasing this product which has passed through our extensive quality assurance process. Every care has been taken to ensure that it reaches you in perfect condition. However, in the unlikely event that you should experience a problem, or if we can offer any assistance or advice please do not hesitate to contact our customer care department. For details of your nearest customer care department please refer to the telephone numbers at the back of this manual.

### **Safety First**

Before attempting to operate this product the following basic safety precautions should always be taken to reduce the risk of fire, electric shock and personal injury. It is important to read the instruction manual to understand the application, limitations and potential hazards associated with this product.

## HELPLINE & SPARE PARTS

---

In the unlikely event of a defect occurring please contact our Helpline.

Office hours: Monday - Friday 9:00am – 5:30pm.

Telephone Number 0844 264 2485

# SAFETY INFORMATION

---

Before attempting to operate the machine, it is essential that you read this manual thoroughly and carefully follow all instructions given. In doing so you will ensure the safety of yourself and that of others around you, and you can also look forward to the welder giving you long and satisfactory service.

## Important

**Warning!** If you have no welding experience, we recommend you seek training from an experienced person.

**Caution:** The pages of this manual are restricted to the basic safe use of an ARC welding power supply and very basic welding technique. We recommend you purchase a good quality publication on welding or if you have internet access visit one of the numerous welding related web sites to be able to use the welding power supply to its full potential.

The electrodes used in an ARC welding are many and varied. You are advised to seek advice from your local welding equipment supplier for the correct selection of wire electrode for the work being performed.

**THE QUALITY OF ANY WELDED JOINT IS DEPENDANT ON THE PREPARATION OF THE JOINT THE SELECTION OF THE CORRECT WIRE ELECTRODE AND THE SKILL AND EXPERIENCE OF THE WELDER.**

## General Welding Safety

### The Workshop Environment

Housekeeping is extremely important to avoid injury from slips, trips and falls, damage to equipment and fire. The work area should be kept clean and tidy at all times. Combustible materials must not be discarded or stored in the vicinity of the welding area.

Avoid using your welder in the vicinity of:

- a) other supply cables, control cables, signalling and telephone cables; above, below and adjacent to the welding equipment;
- b) radio and television transmitters and receivers;
- c) computer and other control equipment;
- d) safety critical equipment, e.g. guarding of industrial equipment;
- e) pacemakers and hearing aids etc.;
- f) equipment used for calibration or measurement;
- g) other equipment in the environment. The user shall ensure that other equipment being used in the environment is compatible. This may require additional protection measures;

It may be possible to avoid the above by changing the time of day that welding or other activities are to be carried out.

The size of the surrounding area to be considered will depend on the structure of the building and other activities that are taking place. The surrounding area may extend beyond the boundaries of the premises.

## Electrical Safety

As one of the principal dangers from welding operations is an electric shock, from the live parts of the welding circuit (the wire electrode torch and the work piece), the following practices are recommended.

## Shock Prevention

Exposed live conductors or other bare metal in the welding circuit, or in unearthed, electrically-LIVE equipment can fatally shock a person whose body becomes a conductor. **DO NOT STAND, SIT, LIE, LEAN ON, OR TOUCH** a wet surface when welding, without suitable protection.

## Protection for Wearers of Pacemakers

Magnetic fields from high currents can affect pacemaker operation. Persons wearing electronic life support equipment (pacemaker) should consult with their doctor before going near arc welding, gouging, or spot welding operations.

## To Prevent Against Shock

Keep body and clothing dry. Never work in damp area without adequate insulation against electrical shock. Stay on a dry duckboard, or rubber mat when dampness or sweat can not be avoided.

# SAFETY INFORMATION

---

Sweat, sea water, or moisture between body and an electrically LIVE part - or earthed metal - reduces the body surface electrical resistance, enabling dangerous and possibly lethal currents to flow through the body.

## Earthing the Equipment

When arc welding equipment is earthed according to the National Electrical Code, and the workpiece is earthed, a voltage may exist between the electrode and any conducting object.

Examples of conducting objects include, but are not limited to, buildings, electrical tools, work benches, welding power source cases, workpieces, etc.

Never touch the electrode and any metal object unless the welding power source is off. When installing, connect the frames of each unit such as welding power source, control, work table, and water circulator to the building earth.

Conductors must be adequate to carry earth currents safely. Equipment made electrically LIVE by stray current may shock, possibly fatally. Do NOT EARTH to electrical conduit, or to a pipe carrying ANY gas or a flammable liquid such as oil or fuel.

## Electrode Holders

Fully insulated electrode holders should be used. Do NOT use holders with protruding screws or with any form of damage.

## Connectors

Fully insulated lock-type connectors should be used to join welding cable.

## Cables

Frequently inspect cables for wear, cracks and damage. IMMEDIATELY REPLACE those with excessively worn or damaged insulation to avoid possibly lethal shock from bared cable. Cables with damaged areas may be taped to give resistance equivalent to original cable. Keep cable dry, free of oil and grease, and protected from hot metal and sparks.

## Terminals And Other Exposed Parts

Terminals and other exposed parts of electrical units should have insulating covers secured before operation.

## Electrode

### Equipment With Output On/Off Control (Contactor)

Welding power sources for use with the gas metal arc welding, gas tungsten arc welding and similar processes normally are equipped with devices that permit on/off control of the welding power output. When so equipped the electrode wire becomes electrically LIVE when the power source switch is ON and welding gun switch is closed. Never touch the electrode wire or any conducting object in contact with the electrode circuit unless the welding power source is off.

### Equipment Without Output On/Off Control (No Contactor)

Welding power sources used with shielded metal arc welding and similar processes may not be equipped with welding power output on/off control devices. With such equipment the electrode is electrically LIVE when the power switch is turned ON. Never touch the electrode unless the welding power source is off.

## Changing Electrodes

In ARC welding, the electrode holder should be isolated when changing the electrode, where a work piece is earthed. If the electrode is changed without isolating the electrode holder, the welder is relying on the insulation properties of the glove to avert shock from the OCV (Open Circuit Voltage) which can be 80V between the electrode and earth. If the glove is wet, the electrode a bad insulator or the welder in contact with a conductive surface, one or more of these layers of insulation may be ineffective.

## Safety Devices

Safety devices such as interlocks and circuit breakers should not be disconnected or shunted out. Before installation, inspection, or service of equipment, shut OFF all power and remove line fuses (or lock or red-tag switches) to prevent accidental turning ON of power. Do not open power circuit or change polarity while welding. If, in an emergency, it must be disconnected, guard against shock burns, or flash from switch arcing.

Always shut OFF and disconnect all power to equipment. Power disconnect switch must be available near the welding power source.

# SAFETY INFORMATION

---

## Checking the Equipment

Check that the equipment is suitable for the operation and connected in accordance with the manufacturer's recommendations. The welder is responsible for checking the equipment (cable, electrode holder and coupling devices) daily for damage and defects. All external connections should be clean and tight and checked each time a reconnection is made. The welding return clamp should be connected directly to the work piece, as close as possible to the point of welding or to the metal work bench on which the work piece is placed. Any damaged or defective parts must be replaced before continuing the welding operation.

## Fumes

The welding process vaporises metals, and anything that is resting on the surface. This gives rise to fumes, which is condensed fine particulate material. The fume is mostly oxides of the metals, including any alloying elements, but it also contains gases produced in the arc, such as ozone or oxides of nitrogen, and decomposition products from any paint or coating which was on the metal surface. The nature and quantity of this fume depends critically upon the welding process, the materials and the welding parameters.

Severe discomfort, illness or death can result from fumes, vapours, heat, or oxygen enrichment or depletion that welding (or cutting) may produce. Prevent them with adequate ventilation. NEVER ventilate with oxygen. Lead-, cadmium-, zinc-, mercury- and beryllium-, bearing materials, when welded (or cut) may produce harmful concentrations of toxic fumes. Adequate local exhaust ventilation must be used, or each person in the area as well as the operator must wear an air-supplied respirator. For beryllium, both must be used. Metals coated with or containing materials that emit toxic fumes should not be heated unless coating is removed from the work surface, the area is well ventilated, or the operator wears an air-supplied respirator. Work in a confined space only while it is being ventilated and, if necessary, while wearing an air-supplied respirator. Vapours from chlorinated solvents can be decomposed by the heat of the arc (or flame) to form PHOSGENE, a highly toxic gas, and other lung and eye

irritating products. The ultraviolet (radiant) energy of the arc can also decompose trichloroethylene and perchloroethylene vapours to form phosgene. DO NOT WELD or cut where solvent vapours can be drawn into the welding or cutting atmosphere or where the radiant energy can penetrate to atmospheres containing even minute amounts of trichloroethylene or perchloroethylene.

## Noise

Welding environments are frequently noisy as other operations such as grinding, etc. may also be taking place. Some operations, such as de-sludging may take the noise up to such a level where it will damage hearing. In such cases hearing protection must be used.

## Optical Radiation

The welding process produces a large quantity of visible light, ultraviolet and infrared. Exposure to the radiation from an arc causes damage to the eyes (Arc Eye). For this reason, welders need to wear efficient eye protection, which is usually supplied in the form of a protective shield.

The precise choice of the shade of glass filter in these shields depends on the type of welding operation, since they vary in their light output.

## Hand Held and Head Shields

For most operations a hand-held or head shield constructed of lightweight insulating and non-reflecting material is used which conforms to EN175. The shield is fitted with a protective filter glass, sufficiently dark in colour and capable of absorbing the harmful infrared and ultraviolet rays. The filter glasses conform to the strict requirements of EN169 and are graded according to a shade number which specifies the amount of visible light allowed to pass through - the lower the number, the lighter the filter. The correct shade number for ARC welding must be used according to the welding current level, for example:

- Shade 9 - up to 40A
- Shade 10 - 40 to 80A
- Shade 11 - 80 to 175A
- Shade 12 - 175 to 300A
- Shade 13 - 300 to 500A

# SAFETY INFORMATION

---

**Note:** The current ranges are different for other processes.

Welders assistants also need protective clothing and eye protection. Passers-by should be protected by placing opaque or properly filtered screens around the work area.

## **Burns and Mechanical Hazards**

Exposure to the radiation from an arc causes burns to the skin. For this reason, welders need to wear clothing to protect their bodies and arms, regardless of the weather conditions.

Welders need good quality gloves, preferably leather gauntlets, safety boots or shoes and good quality cap and overalls. A leather apron may also be needed. Welding produces quantities of molten droplets of metal which are scattered in all directions. It is essential that the welder wears clothing which will not burn or melt, and which is stout enough to provide adequate protection.

## **Fire and Explosion Prevention**

Causes of fire and explosion are:

- 1) combustibles reached by the arc, flame, flying sparks, hot slag or heated material;
- 2) misuse of compressed gases and cylinders;
- 3) short circuits.

BE AWARE THAT flying sparks or falling slag can pass through cracks, along pipes, through windows or doors, and through wall or floor openings, out of sight of the goggled operator. Sparks and slag can fly 10M.

To prevent fires and explosion: keep equipment clean and operable, free of oil, grease, and (in electrical parts) of metallic particles that can cause short circuits.

If combustibles are in area, do NOT weld or cut. Move the work if practicable, to an area free of combustibles.

Avoid paint spray rooms, dip tanks, storage areas, ventilators. If the work cannot be moved, move combustibles at least 10M, away out of reach of sparks and heat; or protect against ignition with suitable and snug fitting, fire-resistant covers or shields.

Walls, ceilings, and floor near work should be protected by heat resistant covers or shields. Fire watcher must be standing by with suitable fire extinguishing equipment during and for some time after welding or cutting if:

- a) appreciable combustibles (including building construction) are within 10m.
- b) appreciable combustibles are further than 10m but can be ignited by sparks.
- c) openings (concealed or visible) in floors or walls within 10m can expose combustibles to sparks.
- d) combustibles adjacent to walls, ceilings, roofs or metal partitions can be ignited by radiant or conducted heat.

After work is done, check that area is free of sparks, glowing embers, and flames.

An empty container that held combustibles, or that can produce flammable or toxic vapours when heated, must never be welded on or cut, unless container has first been cleaned. This includes a thorough steam or caustic cleaning (or a solvent or water washing, depending on the combustible's solubility) followed by purging and inerting with nitrogen or carbon dioxide, and using protective equipment.

Water filling just below working level may substitute for inerting.

A container with unknown contents should be cleaned (see paragraph above), do NOT depend on sense of smell or sight to determine if it is safe to weld or cut.

Hollow castings or containers must be vented before welding or cutting - they can explode.

In explosive atmospheres, never weld or cut where the air may contain flammable dust, gas, or liquid vapours.

## **Specific Safety Instructions**

Use the welding power supply as indicated in the instruction manual. Improper use of this welding power supply can be dangerous for persons, animals or objects.

# SAFETY INFORMATION

---

The user of the welding power supply is responsible for his own safety and the safety of others. It is important to read and understand this instruction manual.

Repair and maintenance must be carried out by qualified persons.

Maintain the machine in good condition (keep clean and dry etc).

During welding do not locate the machine in a confined space or close to a wall, which will block air outlets.

Avoid stretching the supply cable, disconnect from the mains supply before moving the machine.

Keep welding cables, earth clamp and electrode holder in good condition.

Welders should not wear jewellery (especially rings) or metallic watch straps

Appropriate clothing should be worn. Gloves, boots and overalls will provide some protection from electric shock

The welder should check daily, and after each reconnection, that all external connections are clean and tight

When changing the electrode, the electrode holder should be isolated

When welding stops for a short time, the electrode holder should not be put on the face shield or flammable material as it may still be 'live' at 80V or hot enough to cause damage

Arc welding produces fumes, sparks and fused metal projectiles.

Remove all flammable substances and materials from the work area.

Ensure adequate ventilation in areas where welding is being performed.

Do not weld on containers or pipes that hold or have held flammable liquid or gases (danger of explosion) or on materials cleaned with chlorinated solvents or on varnished surfaces (danger of toxic fumes).

Remove all flammable materials from the work area.

Ensure there is adequate fire fighting equipment close by.

Avoid direct contact with welding circuit, the OCV (Open Circuit Voltage) between the electrode and the earth clamp can be dangerous.

Do not use the welding power supply in damp or wet places or weld in the rain.

Always protect your eyes with an approved face mask. Use gloves and proper protective clothing which are dry and not soiled by oil or grease.

Avoid exposing skin to the ultra violet rays produced by the arc.

## **Environments with Increased Hazard of Electric Shock**

These are as follows:

locations where the welder has restricted freedom of movement, working in a cramped position (kneeling or sitting) or in contact with conductive parts.

Areas which are fully or partially restricted by conductive elements with which the welder is likely to make accidental contact.

Welding in wet, damp or humid conditions which reduces the skin resistance of the body and insulating properties of accessories.

Where electrically conductive parts have been insulated close to the welder, there is no increased shock hazard.

## **Working in the Open Air**

When welding outside, the equipment should have the appropriate level of waterproofing; see manufacturer's Rating Plate (IP) codes for enclosures:

IP 23 protection against limited spraying

IP 24 protection against spraying from all directions

If there is a risk of heavy rain, a cover for the welding power supply, equipment and workpiece should be in place.



# SAFETY INFORMATION

---

The following types of welding operation must be performed by a qualified coded welder and approved by a qualified welding inspector.

- The welding of pressure vessels for liquid and gaseous substances.
- The welding of pressurised pipe work for liquid and gaseous substances.
- The repair of containers for flammable liquids and corrosive chemicals.
- Structural support and load bearing steelwork in buildings.
- Load lifting and moving equipment.
- Load lifting slings, chains, hooks and shackles.
- Hydraulic systems.
- Any type of safety critical equipment.

In addition to the above it is strongly recommended that the following welding operations are checked by a competent person.

- The repair of vehicle chassis and suspension and steering components.
- Vehicle load bearing attachment points ie, engine mounts seat and seat belt anchor points.
- Motor Cycle frames and components.

## General Safety Rules

**Warning!** Read all instructions Failure to follow all instructions listed below may result in electric shock, fire and/or serious injury. The term "power tool" in all of the warnings listed below refers to your mains operated welder.

## Save These Instructions

### 1) Work Area

- a) **Keep work area clean and well lit.**  
Cluttered and dark areas invite accidents.
- b) **Do not operate power tools in explosive atmospheres, such as in the presence of flammable liquids, gases or dust.** Power tools create sparks which may ignite the dust or fumes.

- c) **Keep children and bystanders away while operating a power tool.** Distractions can cause you to lose control.

### 2) Electrical Safety

- a) **Power tool plugs must match the outlet. Never modify the plug in any way. Do not use any adapter plugs with earthed (grounded) power tools.** Unmodified plugs and matching outlets will reduce risk of electric shock.
- b) **Avoid body contact with earthed or grounded surfaces such as pipes, radiators, ranges and refrigerators.**  
There is an increased risk of electric shock if your body is earthed or grounded.
- c) **Do not expose power tools to rain or wet conditions.** Water entering a power tool will increase the risk of electric shock.
- d) **Do not abuse the cord. Never use the cord for carrying, pulling or unplugging the power tool. Keep cord away from heat, oil, sharp edges or moving parts.** Damaged or entangled cords increase the risk of electric shock.
- e) **When operating a power tool outdoors, use an extension cord suitable for outdoor use.** Use of a cord suitable for outdoor use reduces the risk of electric shock.

### 3) Personal Safety

- a) **Stay alert, watch what you are doing and use common sense when operating a power tool. Do not use a power tool while you are tired or under the influence of drugs, alcohol or medication.**  
A moment of inattention while operating power tools may result in serious personal injury.
- b) **Use safety equipment. Always wear eye protection.** Safety equipment such as dust mask, non-skid safety shoes, hard hat, or hearing protection used for appropriate conditions will reduce personal injuries.

# SAFETY INFORMATION

---

c) **Avoid accidental starting. Ensure the switch is in the off position before plugging in.** Carrying power tools with your finger on the switch or plugging in power tools that have the switch on invites accidents.

d) **Remove any adjusting key or wrench before turning the power tool on.** A wrench or a key left attached to a rotating part of the power tool may result in personal injury.

e) **Do not overreach. Keep proper footing and balance at all times.** This enables better control of the power tool in unexpected situations.

f) **Dress properly. Do not wear loose clothing or jewellery. Keep your hair, clothing and gloves away from moving parts.** Loose clothes, jewellery or long hair can be caught in moving parts.

g) **If devices are provided for the connection of dust extraction and collection facilities, ensure these are connected and properly used.** Use of these devices can reduce dust related hazards.

## 4) Power Tool Use And Care

a) **Do not force the power tool. Use the correct power tool for your application.** The correct power tool will do the job better and safer at the rate for which it was designed.

b) **Do not use the power tool if the switch does not turn it on and off.** Any power tool that cannot be controlled with the switch is dangerous and must be repaired.

c) **Disconnect the plug from the power source before making any adjustments, changing accessories, or storing power tools.** Such preventive safety measures reduce the risk of starting the power tool accidentally.

d) **Store idle power tools out of the reach of children and do not allow persons unfamiliar with the power tool or these instructions to operate the power tool.**

Power tools are dangerous in the hands of untrained users.

e) **Maintain power tools. Check for misalignment or binding of moving parts, breakage of parts and any other condition that may affect the power tools operation. If damaged, have the power tool repaired before use.** Many accidents are caused by poorly maintained power tools.

f) **Keep cutting tools sharp and clean.** Properly maintained cutting tools with sharp cutting edges are less likely to bind and are easier to control.

g) **Use the power tool, accessories and tool bits etc., in accordance with these instructions and in the manner intended for the particular type of power tool, taking into account the working conditions and the work to be performed.** Use of the power tool for operations different from intended could result in a hazardous situation.

## 5) Service

a) **Have your power tool serviced by a qualified repair person using only identical replacement parts.** This will ensure that the safety of the power tool is maintained.

# ELECTRICAL INFORMATION

---

## **WARNING! THIS APPLIANCE MUST BE EARTHED**

### **Models Fitted With 13A Plug**

Welders fitted with a standard 13 amp BS 1363 plug, should be connected to a 230 volt (50Hz) domestic electrical supply and we strongly recommend that this be done via a Residual Current Device (RCD).

**IMPORTANT: If the welder is fitted with a plug which is moulded onto the electric cable (i.e. non- re-wirable) please note:**

1. The plug must be thrown away if it is cut from the electric cable. There is a danger of electric shock if it is subsequently inserted into a socket outlet.
2. Never use the plug without the fuse cover fitted.
3. Should you wish to replace a detachable fuse carrier, ensure that the correct replacement is used (as indicated by marking or colour code). Replacement fuse covers can be obtained from your local dealer or most electrical stockists.

### **Fuse Rating**

The fuse in the plug must be replaced with one of the same rating (13 amps) and this replacement must be ASTA approved to BS1362.

### **Models Fitted Without Plug**

#### **230V Supply**

Connect the mains lead to a suitably fused 230 Volt (50Hz) electrical supply. The fuse rating should correspond to that shown on the technical specification on page 11.

**The wires in the mains lead are coloured in accordance with the following code:**

**Green & Yellow:** Earth

**Blue:** Neutral

**Brown:** Live

As the colours of the flexible cord of this appliance may not correspond with the

coloured markings identifying terminals in your plug, proceed as follows:

- Connect GREEN & YELLOW cord to plug terminal marked with a letter "E" or Earth symbol "⊕", or coloured GREEN or GREEN & YELLOW.
- Connect BROWN cord to plug terminal marked letter "L" or coloured RED.
- Connect BLUE cord to plug terminal marked letter "N" or coloured BLACK.

# COMPONENTS

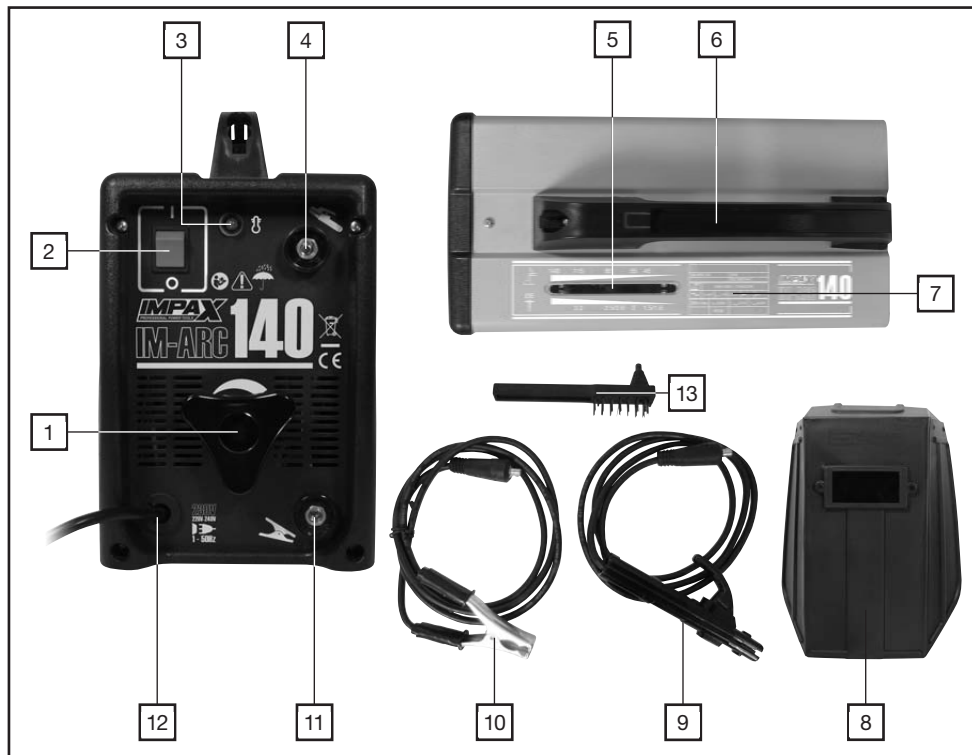

## Component List

- |                                      |                                  |
|--------------------------------------|----------------------------------|
| 1. Regulator knob                    | 7. Technical table               |
| 2. ON/OFF switch                     | 8. Face mask                     |
| 3. Thermal cut out indicator         | 9. Electrode holder              |
| 4. Electrode holder attachment point | 10. Earth clamp                  |
| 5. Amp graduated scale               | 11. Earth clamp attachment point |
| 6. Carry handle                      | 12. Power lead                   |
|                                      | 13. Wire brush/chipping hammer   |

## Technical specification

Input power:	230-240V~50Hz
Phase:	1
Rated input current:	27A
Air switch:	40A
Fuse:	16A
Rated no load voltage:	48V DC
Rated input capacity:	6.3kVA

Duty cycle:	10% @ 115A
Output current range:	40-115A
Peak current:	140A
Insulation grade:	H
Cooling type:	Fan cooled
Case protection class:	IP23S
External dimensions:	370 x 350 x 175mm
Weight:	15.7kg

# UNPACKING AND ASSEMBLY

## Unpacking

**Caution!** This packaging contains sharp objects. Take care when unpacking. Remove the machine, together with the accessories supplied, from the packaging. Check carefully to ensure that the machine is in good condition and account for all the accessories listed in this manual. Also make sure that all the accessories are complete. If any parts are found to be missing, the machine and its accessories should be returned together in their original packaging to the retailer.

Do not throw the packaging away, keep it safe throughout the guarantee period, then recycle if possible, otherwise dispose of it by the proper means. Do not let children play with empty plastic bags due to the risk of suffocation.

## Assembly

**Note:** Before carrying out any assembly or disassembly of the unit please ensure that the unit is not connected to the electrical supply.

### Assembling the Face Mask

To assemble the mask bend in the top and side flaps (Fig.1) and clip into place then attach the handle and mask glass shield as shown in Fig.2.

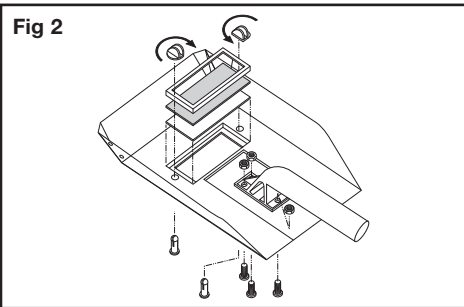
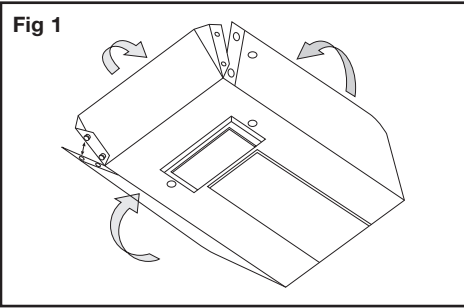

Insert the clear glass panel first, followed by the dark glass panel into the recess in the shield, i.e. the clear glass panel **MUST** be on the outside of the shield. Securing them with the plastic screws provided.

The dark panel is a certified, specific optical class, and should not be exchanged for any other type.

The clear glass panel should be replaced when it becomes badly pitted.

**Warning!** NEVER look at an electric arc without eye protection as this can injure the eyes permanently. ALWAYS use a protection mask or welding helmet.

### Fitting the Carry Handle

To attach the carry handle to the welder slide the handle onto the recess on the back of the machine and then secure with the screw provided as shown in Fig.3.

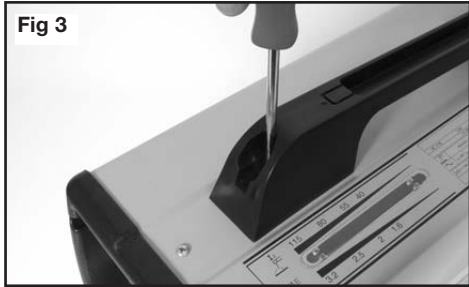

### Fitting the Earth Clamp and Electrode Holder

Insert the plug on the end of the earth clamp lead into the socket with the clamp symbol (Fig.4)(A) and twist in a clockwise direction to secure into position. The plug on the end of the electrode holder is fitted into the socket marked with an electrode symbol (B) in the same way.



# OPERATION

## Description

Your Welding Power Supply features a single phase transformer suitable for welding with an alternating current using stick electrodes with diameters from 2mm to 3.2mm. The welding current is regulated by using the screw type stepless welding current control (regulator). The value of the current may be read on the Amp graduated scale.

## Electrode Selection.

The pages of this manual are restricted to the basic safe use of an ARC welding power supply and very basic welding technique. The electrodes used in ARC welding are many and varied. You are advised to seek advice from your local welding equipment supplier for the correct selection of electrode for the work being performed.

## Operation

**Warning!** If you have no welding experience, we recommend you seek training from an experienced person.

**Caution:** This manual is a basic guide to welding. We recommend you purchase a good quality publication on welding or if you have internet access visit one of the numerous welding related web sites to be able to use the welding power supply to its full potential.

**THE QUALITY OF ANY WELDED JOINT IS DEPENDANT ON THE PREPARATION OF THE JOINT THE SELECTION OF THE CORRECT ELECTRODE AND THE SKILL AND EXPERIENCE OF THE WELDER.**

**Ensure the Welding Power Supply is disconnected from the mains supply.**

Ensure that the area of the work piece where the earth clamp is to be connected is clean using a file or a grinder, to ensure a good electrical contact.

Ensure the earth lead is connected to the workpiece, and the other lead to the electrode holder.

**Important:** Ensure also that the earth clamp is attached to clean, solid metal. If necessary thoroughly clean with a wire brush or similar to guarantee a good connection.

The earth clamp must only be connected to the work piece. The area to be welded must be clean and free from dirt, rust, paint, grease and oil.

Insert an electrode into the electrode holder (Fig.5) ensuring there is a good connection.



Set the amperage (see Table 1) by adjusting the regulator (Fig.6)(A) until the desired setting is reached on the amp graduated scale (Fig.6)(B).

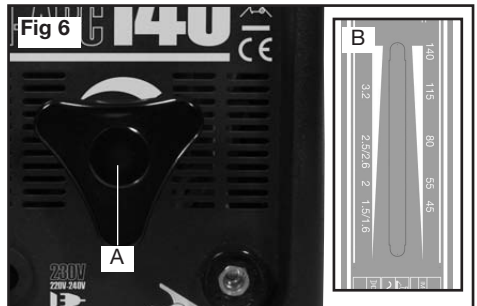

**Note:** With practice you will get a feel for the best current settings for different welding rod thicknesses.

The chart below is an indicator of the electrode diameter and the corresponding welding current. This is intended as a guide only.

<b>Electrode diameter (mm)</b>	<b>Amperage (A)</b>
1.5 mm	40-55
2.0 mm	50-70
2.5 mm	75-95
3.25mm	100-140

# OPERATION

**Warning!** Always wear a full face mask, welding gloves and protective clothing. Wear goggles while chipping slag.

Do not switch on the power supply until you are ready to start welding. Practice welding on a piece of scrap material.

Connect to the mains supply and press the On/Off switch (Fig.7) to the ON position (I) to stop the machine press the On/Off switch to the OFF position (O).



**Note:** If the machine stops at any time and the amber light on the front panel illuminates, the thermal cutout has intervened. Wait until the transformer has cooled sufficiently for work to recommence. This could take considerable time and is denoted by the amber light going out.

Holding the face mask in front of your face stroke the electrode point on the workpiece as if striking a match. Maintain a steady gap between the end of the electrode and the workpiece of approximately 2mm (Fig.8).

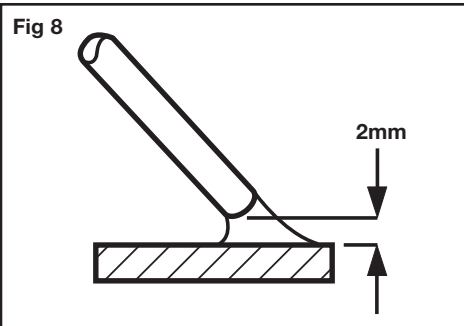

Maintain this distance as constantly as possible during the weld remember that the angle of the electrode to the work piece must be 20-30° (Fig.9).

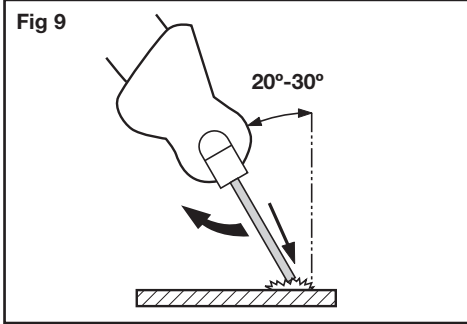

Do not hit the electrode on the workpiece as this may damage the electrode. Withdraw with a clean movement at the end of the welding run.

**Note:** This is the most difficult aspect for most beginners. It is recommended that you practice on some scrap material in order to get a feel of the operation.

If the electrode is not withdrawn quickly enough once the arc is primed, there is a possibility that the electrode will weld itself to the workpiece. Should this happen, give it a sharp tug to free it, and try again. If this fails to free it, turn off the machine immediately as it will quickly overheat.

If you withdraw the electrode too far once the arc is primed, you will lose the arc and have to try again.

Inspect the job carefully. With a correct combination of electrode size and current setting the area of weld should be complete fusion of the electrode and parent metal/s. Any slag which forms on the surface should be chipped away with the pick/brush supplied.

If the resultant weld looks messy and irregular, this is an indication of porosity or slag contamination, and you have almost certainly failed to achieve the correct combination. This is a common problem, so do not worry as practice will quickly cure this.

# OPERATION

When welding material up to 7mm in thickness place the pieces 2-3mm apart, run the welding bead along the join. A second bead can go along the underside for extra strength (Fig.10).

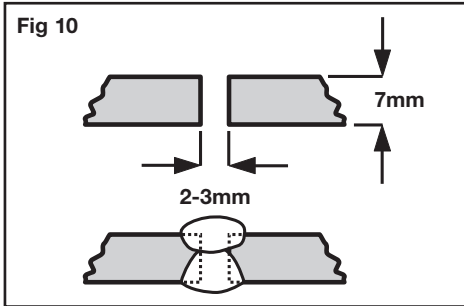

When welding material from 7mm to 30mm thick prepare the material as shown in Fig.11 filling up the space with several layers of weld.

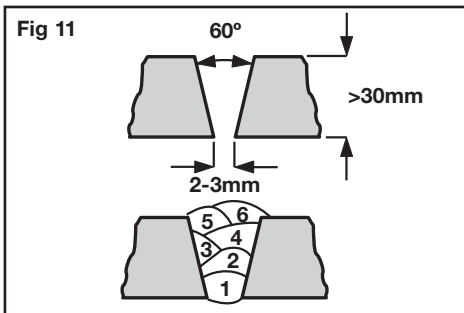

When welding together material over 30mm in thickness prepare the material as shown in Fig.12 filling up the space with several layers of weld, welding each side in turn with each welding pass.

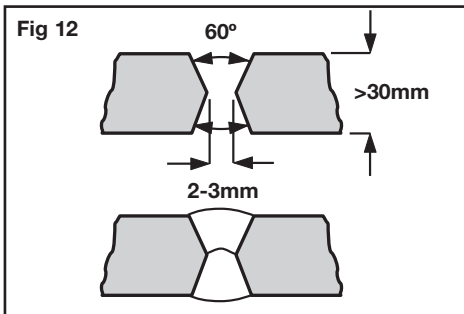

Disconnect the Welding Power Supply from the mains supply before changing or removing electrodes. Use pliers to remove used electrodes from the electrode holder or to move the welded pieces.

## The Manual Metal Arc Process

When an arc is struck between the metal rod (electrode) and the workpiece, both the rod and workpiece surface melt to form a weld pool. Simultaneous melting of the flux coating on the rod will form gas and slag which protects the weld pool from the surrounding atmosphere. The slag will solidify and cool and must be chipped off the weld bead once the weld run is complete (or before the next weld pass is deposited).

The process allows only short lengths of weld to be produced before a new electrode needs to be inserted in the holder. Weld penetration is low and the quality of the weld deposit is highly dependent on the skill of the welder.

## Types of Flux/Electrodes

Arc stability, depth of penetration, metal deposition rate and positional capability are greatly influenced by the chemical composition of the flux coating on the electrode. Electrodes can be divided into three main groups:

- Cellulosic
- Rutile
- Basic

**Cellulosic electrodes** contain a high proportion of cellulose in the coating and are characterised by a deeply penetrating arc and a rapid burn-off rate giving high welding speeds. Weld deposit can be coarse and with fluid slag, deslagging can be difficult. These electrodes are easy to use in any position and are noted for their use in the stovepipe (vertical down position) welding technique.

## Features:

- Deep penetration in all positions
- Suitability for vertical down welding
- Reasonably good mechanical properties
- High level of hydrogen generated - risk of cracking in the heat affected zone



# OPERATION

---

**Rutile Electrodes** contain a high proportion of titanium oxide (rutile) in the coating. Titanium oxide promotes easy arc ignition, smooth arc operation and low spatter. These electrodes are general purpose electrodes with good welding properties. They can be used with AC and DC power sources and in all positions. The electrodes are especially suitable for welding fillet joints in the horizontal/vertical position.

## Features:

- Moderate weld metal mechanical properties
- Good bead profile produced through the viscous slag
- Positional welding possible with a fluid slag (containing fluoride)
- Easily removable slag

**Basic electrodes** contain a high proportion of calcium carbonate (limestone) and calcium fluoride (fluorspar) in the coating. This makes their slag coating more fluid than rutile coatings - this is also fast-freezing which assists welding in the vertical and overhead position. These electrodes are used for welding medium and heavy section fabrications where higher weld quality, good mechanical properties and resistance to cracking (due to high restraint) are required.

## Features:

- Low hydrogen weld metal
- Requires high welding currents/speeds
- Poor bead profile (convex and coarse surface profile)
- Slag removal difficult

Iron powder electrodes contain an addition of metal powder to the flux coating to increase the maximum permissible welding current level. Thus, for a given electrode size, the metal deposition rate and efficiency (percentage of the metal deposited) are increased compared with an electrode containing no iron powder in the coating. The slag is normally easily removed. Iron powder electrodes are mainly used in the flat and horizontal/vertical positions to take advantage of the higher deposition rates.

Efficiencies as high as 130 to 140% can be achieved for rutile and basic electrodes without marked deterioration of the arcing characteristics but the arc tends to be less forceful which reduces bead penetration.

## Care of Electrodes

The quality of weld relies upon consistent performance of the electrode. The flux coating should not be chipped, cracked or, more importantly, allowed to become damp.

## Storage

Electrodes should always be kept in a dry and well-ventilated store. It is good practice to stack packets of electrodes on wooden pallets or racks well clear of the floor. Also, all unused electrodes which are to be returned should be stored so they are not exposed to damp conditions to regain moisture. Good storage conditions are 100°C above external air temperature. As the storage conditions are to prevent moisture from condensing on the electrodes, the electrode stores should be dry rather than warm. Under these conditions and in original packaging, electrode storage time is practically unlimited. It should be noted that electrodes are now available in hermetically sealed packs which obviate the need for drying. However, if necessary, any unused electrodes must be redried according to manufacturer's instructions.

## Drying of Electrodes

Drying is usually carried out following the manufacturer's recommendations and requirements will be determined by the type of electrode.

## IMPORTANT – Thermostatic Protection (Duty Cycle)

This product has a rated duty cycle of 10%. The percentage represents the welding time in a 10 minute period for example 10% means that the welding time is 1 minute with a rest time of 9 minutes in a ten minute period although the actual duty cycle will depend on the amperage used. If the Welding Power Supply is used for longer than the duty cycle or if you are welding using large welding rods you may experience a temporary current shut off. This is to protect the transformer inside the Welding Power Supply from overheating.

# OPERATION AND MAINTENANCE

---

The thicker the material being welded, the greater the current required, therefore, the hotter the machine will become and the quicker it will cut out. When the windings reach performance temperature the cut out switch will operate illuminating the indicator lamp on the front panel (Fig. 13). After a few minutes the cut out switch will reset and the welder will be ready for use.

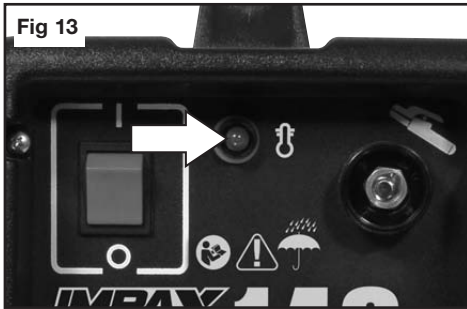

Fig 13

## Maintenance

**Warning!** Ensure the welder is disconnected from the electrical mains power supply before attempting any service or maintenance.

The welder must be kept clean and dry at all times. Use a dry cloth to clean the welder.

Keep the electrodes clean and dry and ensure all cables are in good condition.

Keep the louvre passages clean to avoid a build up of dirt and oxides inside the machine, which can reduce machine output.

Always try to avoid getting particles of metal inside the machine since they could cause short circuits.

Periodically clean the inside of the welder with compressed air, ensuring you wear a mask during the operation.

**Important** - Always disconnect from the electrical supply before servicing or cleaning.

**Caution:** Water must never come into contact with the welder.

Regularly check that all the fixing screws are tight. They may vibrate loose over time.

If the supply cord requires replacing, the task must be carried out by the manufacturer, the

manufacturer's agent, or an authorised service centre to avoid a safety hazard.

## Welding Mask Maintenance

Always maintain the welding mask in good condition. If the clear glass protection lens becomes badly pitted, sufficient to interfere with vision, or cracked, have it replaced immediately.

NEVER use any dark filter lens other than that provided by Impax, or one with the same certified 'Optical class' (degree of protection).

The shield should always be cleaned with a clean soft cloth after use, ensuring the lenses are clean. Remove any dust that may have accumulated and store it in a safe place where it cannot be damaged.

NEVER use a shield that is not in perfect condition.

# TROUBLESHOOTING

Troubleshooting Guide		
Problem	Possible Cause	Remedy
No weld current (plug fuse blowing).	Blown rectifier.	Replace rectifier.
No weld current	Poor earth clamp connection. Break in torch lead. Replace earth lead.	Break in earth lead. Check and clean up connections. Replace torch or lead.
Unstable arc.	Incorrect settings. Impurities in the weld area.	Check settings. Clean the weld area prior to welding.
Weld current interrupted.	Thermal trip has operated.	Allow the welder to cool down.
Porous weld.	Rusty or dirty joints.	Clean the weld area prior to welding.
Irregular weld cap.	Torch incorrectly held.	Weld with the electrode at the correct distance and angle to the workpiece.
Poor penetration.	Weld current too low. Arc too long	Adjust settings. Move the electrode closer to the workpiece.
Excessive penetration.	Weld current too high. Torch is too far from the workpiece.	Adjust settings. Weld with the electrode at the correct distance from the workpiece.

# ENVIRONMENTAL PROTECTION & SYMBOLS

---

Information for (private householders) for the environmentally responsible disposal of Waste Electrical and Electronic Equipment (WEEE)



This symbol on products and or accompanying documents indicates that used and end of life electrical and electronic equipment should not be disposed of in household waste. For the proper disposal, treatment, recovery and recycling, please take these products to designated collection points, where they will be accepted on a free of charge basis. Alternatively, in some countries you may be able to return your products to your retailer upon the purchase of an equivalent new product. Disposing of this product correctly will help to save valuable

resources and prevent any potential adverse effects on human health and the environment which could otherwise arise from inappropriate waste disposal and handling. Please contact your local authority for further details of your nearest designated collection point. Penalties may be applicable for incorrect disposal of this waste in accordance with national legislation.

## FOR BUSINESS USERS IN THE EUROPEAN UNION.

If you wish to discard electrical and electronic equipment, please contact your dealer or supplier for further information.

## Information on Disposal in other Countries outside the European Union.

This Symbol is only valid in the European Union.

If you wish to dispose of this product, please contact your local authorities or dealer and ask for the correct method of disposal.

---

The rating plate on this product may show symbols. These represent important information about the product or instructions on its use.



Conforms to relevant safety standards.



Read the instruction manual.



Product conforms to RoHS requirements



Warning! Electrical welding process



Protect operator and passer by from the effect of uV radiation. This can cause permanent damage to the eye. Make sure the arc and resulting flash is shielded at all times.



Waste electrical products should not be disposed of with household waste. Please recycle where facilities exist. Check with your Local Authority or retailer for recycling advice



Always wear approved face mask with correct filter, gloves and apron to protect against welding operation







Do not use this welder in damp conditions



Keep bystanders and pets clear of the welding power supply when in use.

# SYMBOLS

Symbols and Technical Data	
EN 60974-6:2003	European standard relating to Welding Power Supply's for limited use
IM-ARC140	Type ID
	Single phase transformer
	Symbol for manual arc welding and covered electrodes
50Hz	Nominal mains frequency
Ø	Diameter of electrodes
$U_0$	No load voltage
...A/...V to ...A/...V	Range of output
X%	Duty cycle
$I_2$	Conventional welding current
$U_2$	Conventional load voltage
$U_1$	Mains voltage
$I_1 \text{ max}$	Maximum absorbed current
$I_1 \text{ eff}$	Effective supply current
IP21S	Grade of protection
	Standardized plug
	Suitable for welding in an environment with increased hazard of electric shock

# NOTES

---

# NOTES

---

# NOTES

---