

ENERGER

350W Drill Press

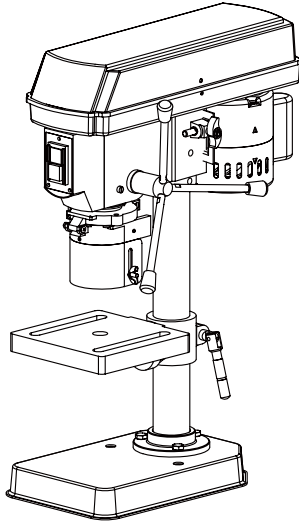

ENB540DBT

Barcode:5052931253630



Warning! Read the instructions before using the product!

The logo for ENERGER features the brand name in a bold, italicized, sans-serif font. The word 'ENERGER' is centered and flanked on both sides by a stylized graphic consisting of three horizontal bars of varying lengths, creating a sense of motion or energy.



Thank you for choosing a product **ENERGER** it will give you full satisfaction in your craft in the work.

The band saw is a product easy to use, it comes with accessories. For best use, you must read this notice. It will provide key information on the functions of the device and the rules to follow for maintenance.

Please keep this manual for future reference later.

Let's get started...

These instructions are for your safety. Please read through them thoroughly before use and retain them for future reference.

	Getting started	03
	Your product	04
	Technical and legal information	05
	Before you start	12
	In more detail	18
	Product functions	19
	Care and maintenance	24
	Trouble shooting	28
	Recycling and disposal	30
	Guarantee	31
	EC declaration of conformity	32

Your product

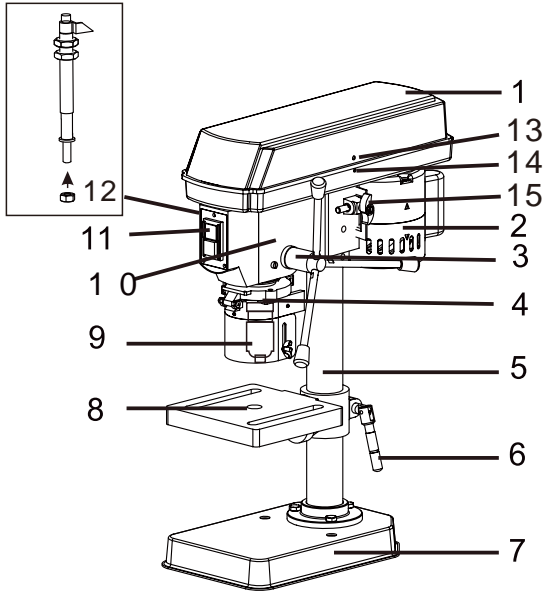

- | | |
|-----------------|------------------------------|
| 1. Pulley guard | 9. Chuck |
| 2. Motor | 10. Machine casing |
| 3. Feed handles | 11. On/off switch |
| 4. Chuck guard | 12. Drill depth gauge |
| 5. Column | 13. Grub screw |
| 6. Support lock | 14. Pulley guard cross screw |
| 7. Base | 15. Belt tension lock knob |
| 8. Table | |

Technical specifications

> Voltage / Frequency:	230-240 V~ 50 Hz
> Input power:	350 W S2:15min
> No load speed:	500,890,1400,1900,2500 min ⁻¹
> Spindle taper:	B16
> Spindle travel:	50mm
> Max. drilling capacity:	Ø13mm
> Protection class	Class I
> Weight:	13 kg
> Table size:	163x160mm
> Base size:	275x170mm

Noise data & vibration level

- > A weighted sound pressure LpA: 69 dB(A) (KpA:3dB)
- > A weighted sound power: LwA: 82 dB(A) (KpA:3dB)
- > Vibration ah= 3.5m/s² (K=1.5m/s²)

The declared vibration total value has been measured in accordance with a standard test method and may be used for comparing one tool with another.

The declared vibration total value may also be used in a preliminary assessment of exposure.



Warning:

The vibration emission during actual use of the power tool can differ from the declared total value depending on the ways in which the tool is used; and of the need to identify safety measures to protect the operator that are based on an estimation of exposure in the actual conditions of use (taking account of all parts of the operating cycle such as the times when the tool is switched off and when it is running idle in addition to the trigger time).

Symbols

On the product, the rating label and within these instructions you will find among others the following symbols and abbreviations. Familiarise yourself with them to reduce hazards like personal injuries and damage to property.

V~	Volt, (alternating voltage)	min ⁻¹	per minute
W	Watt	mm	Millimetre
A	Ampere	kg	Kilogram
Hz	Hertz	dB(A)	Decibel (A-rated)
kW	Kilowatt	m/s	Metres per second
cm ³	Cubic centimetre	IP20	
yyWxx	Manufacturing date code; year of manufacturing (20yy) and week of manufacturing (Wxx)		



Caution / Warning.



Read the instruction manual.



Wear hearing protection.



Wear eye protection.



Wear respiratory protection.



Switch the product off and disconnect it from the power supply before assembly, cleaning, adjustments, maintenance, storage and transportation.



The product complies with the applicable European directives and an evaluation method of conformity for these directives was done.

Safety warnings



WARNING! When using electric tools basic safety precautions should always be followed to reduce the risk of fire, electric shock and personal injury including the following.

Read all these instructions before attempting to operate this product and save these instructions.

Safe operation

1. Keep work area clear
 - Cluttered areas and benches invite injuries.
2. Consider work area environment
 - Do not expose tools to rain.
 - Do not use tools in damp or wet locations.
 - Keep work area well lit.
 - Do not use tools in the presence of flammable liquids or gases.
3. Guard against electric shock
 - Avoid body contact with earthed or grounded surfaces (e.g. pipes, radiators, ranges, refrigerators).
4. Keep other persons away
 - Do not let persons, especially children, not involved in the work touch the tool or the extension cord and keep them away from the work area.
5. Store idle tools
 - When not in use, tools should be stored in a dry locked-up place, out of reach of children.
6. Do not force the tool
 - It will do the job better and safer at the rate for which it was intended.
7. Use the right tool
 - Do not force small tools to do the job of a heavy duty tool.
 - Do not use tools for purposes not intended; for example do not use circular saws to cut tree limbs or logs.
8. Dress properly
 - Do not wear loose clothing or jewellery, they can be caught in moving parts.
 - Non-skid footwear is recommended when working outdoors.

- Wear protective hair covering to contain long hair.
9. Use protective equipment
 - Use safety glasses.
 - Use face or dust mask if working operations create dust.
 10. Connect dust extraction equipment
 - If the tool is provided for the connection of dust extraction and collecting equipment, ensure these are connected and properly used.
 11. Do not abuse the cord
 - Never yank the cord to disconnect it from the socket. Keep the cord away from heat, oil and sharp edges.
 12. Secure work
 - Where possible use clamps or a vice to hold the work. It is safer than using your hand.
 13. Do not overreach
 - Keep proper footing and balance at all times.
 14. Maintain tools with care
 - Keep cutting tools sharp and clean for better and safer performance.
 - Follow instruction for lubricating and changing accessories.
 - Inspect tool cords periodically and if damaged have them repaired by an authorized service facility.
 - Inspect extension cords periodically and replace if damaged.
 - Keep handles dry, clean and free from oil and grease.
 15. Disconnect tools
 - When not in use, before servicing and when changing accessories such as blades, bits and cutters, disconnect tools from the power supply.
 16. Remove adjusting keys and wrenches
 - Form the habit of checking to see that keys and adjusting wrenches are removed from the tool before turning it on.
 17. Avoid unintentional starting
 - Ensure switch is in "off" position when plugging in.
 18. Use outdoor extension leads
 - When the tool is used outdoors, use only extension cords intended for outdoor use and so marked.

19. Stay alert

- Watch what you are doing, use common sense and do not operate the tool when you are tired.

20. Check damaged parts

- Before further use of tool, it should be carefully checked to determine that it will operate properly and perform its intended function.
- Check for alignment of moving parts, binding of moving parts, breakage of parts, mounting and any other conditions that may affect its operation.
- A guard or other part that is damaged should be properly repaired or replaced by an authorized service centre unless otherwise indicated in this instruction manual.
- Have defective switches replaced by an authorized service centre.
- Do not use the tool if the switch does not turn it on and off.

21. Warning

- The use of any accessory or attachment other than one recommended in this instruction manual may present a risk of personal injury.

22. Have your tool repaired by a qualified person

- This electric tool complies with the relevant safety rules. Repairs should only be carried out by qualified persons using original spare parts, otherwise this may result in considerable danger to the user.

ADDITIONAL SAFETY RULES FOR BENCH DRILL PRESS



Warning!

Ensure that power tools are disconnected from the mains supply when not in use, before servicing, lubricating or making adjustments and when changing accessories such as blades, bits and cutters.

- This machine must be firmly secured to a suitable workbench or other stable work surface. When selecting a suitable location for mounting this machine consideration must be given to the maximum length of the material to be drilled or machined and the position of the operator.
- Before starting the machine ensure that drills and other recommended cutting tools are fitted correctly and that all the securing bolts are tight. Check all guards are fitted and operating correctly and that the chuck key and any other adjustment tools have been removed.
- Keep hands well away from rotating drills and other cutting tools at all times.
- When drilling use the correct cutting lubricant /coolant for the material being drilled. Use only sufficient to prevent the drill from overheating and make sure that

it is kept well away from electrical components. Never use water as a coolant. Keep drills and other cutters sharp and in good condition. This will improve cutting and reduce the load on the machine ensuring a longer life of the cutting tools and the machine.

- Use only drill bits, cutters and other accessories recommended by the manufacturer. Select the correct spindle speed for the size of drill being used. See the instruction manual. Do not attempt to modify the machine or its accessories in any way.
- Do not force the machine, let the machine do the work. This will reduce the wear on the machine and cutter and increase its efficiency and operating life.
- Use approved safety glasses or goggles at all times, and a face mask and ear defenders when using for prolonged periods.
- When drilling long lengths of material ensure that there is adequate support at both ends of the material.

Never use the machine without the safety guards in position and operating correctly.

- When drilling wood and wood type materials, ensure that the work piece is free from any nails or other foreign objects that could damage the drills and other cutting tools.
- Always secure the workpiece in a suitable drill vice.
- Never try and secure the workpiece with your hands.
- Be aware that swarf can be very sharp and hot and can fly off the rotating drill. When handling swarf always wear suitable gloves. Swarf should not be disposed of with domestic waste, it should be disposed of at a recycling centre.
- Never leave the machine running while unattended. If you are interrupted when operating the drill, complete the process and switch off before looking up.
- Always allow the machine to come to a complete stop and disconnect from the power supply before leaving the unit unattended.
- Never use your hands to remove dust, chips or waste close by the drill bit.

Even when the tool is used as prescribed it is not possible to eliminate all residual risk factors. The following hazards may arise in connection with the tool construction and design:

- Contact with the drill bit.
- Kickback of work piece and parts of workpiece.
- Bit fracture.

- Catapulting of bit pieces.
- Damage to hearing if effective ear defenders are not worn.
- Damage to lungs if effective breathing protection is not worn in operations in which dust is produced.
- Damage to sight if effective eye protection is not worn.

Wear goggles

Wear ear defenders

Wear a breathing mask

In more detail...

Unpack

1. Unpack all parts and lay them on a flat, stable surface.
2. Remove all packing materials and shipping devices if applicable.
3. Make sure the delivery contents are complete and free of any damage. If you find that parts are missing or show damage do not use the product but contact your dealer. Using an incomplete or damaged product represents a hazard to people and property.
4. Ensure that you have all the accessories and tools needed for assembly and operation. This also includes suitable personal protective equipment.

You will need

(items not supplied)

Suitable personal protective equipment
 Philips head screwdriver
 3x M8x20mm bolts, washers and nuts for workbench mounting.

(items supplied)

Chuck & chuck key
 4mm Hex key

Assembling the machine

The bench drill comes partially assembled for packaging purposes. Lay the parts on the bench and check against the parts list (Fig.1).

Once it has been established that all parts are correct proceed as follows:

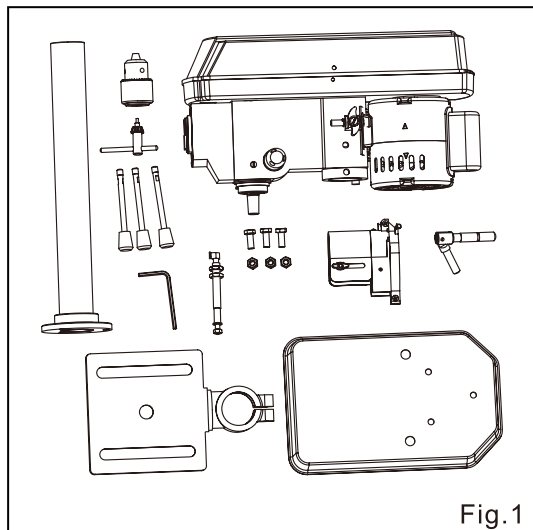

Fig. 1

Mounting the base plate

Select a suitable location for the drill on a workbench. Be aware of table legs and anything which might reduce access to the underneath of the workbench. A suitable mains supply socket must also be accessible for the plug. Locate the base plate(7) in the selected position. Select two suitable length bolts, washers and nuts (not supplied). Using the base plate(7) as a template drill two holes through the workbench. Bolt the base plate(7) to the bench. Do not over tighten as this could crack the cast base plate(Fig.2).

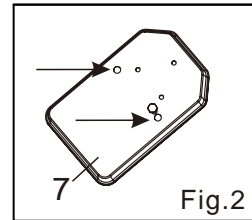

Fig.2

Fitting the column

Align the three threaded holes on the base plate(7) with the column(5) support holes. Secure with the three bolts. Do not over tighten as this could crack the cast base plate(7) and column(5) support(Fig.3).

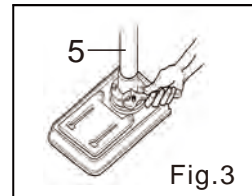

Fig.3

Fitting the table

Lower the table assembly onto the column(5). The assembly will slide easily into position so do not use force. Make sure the table assembly will rotate 360°. Tighten the support lock to secure the table assembly into position(Fig.4).

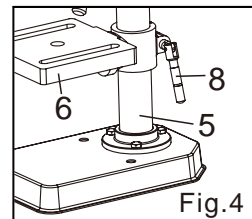
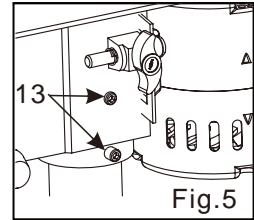

Fig.4

Fitting the head stock and motor

Locate the two grub screws in the side of the head stock and motor assembly. Using a hexagonal key slacken the two grub screws. Lift the head stock and motor assembly and lower it onto the column. Make sure that it slides down and locates fully on the column. Position the head stock and motor assembly ensuring it is aligned with the base plate(7). Tighten the two grub screws to secure the head stock and motor assembly into place(Fig.5). Retain the hexagonal keys for future adjustments.



Fitting the hand feed handles

Locate and install the three hand feed handles(3). Simply screw the handles(3) into the three threaded holes located in the feed shaft boss. Make sure that all three handles(3) are tight(Fig.6).

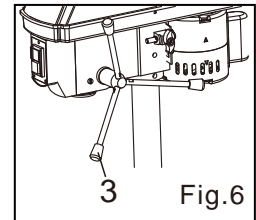

Fitting the chuck guard

Warning: never attempt to use the machine without the chuck guard(4) fitted.

The telescopic chuck guard(4) is partially assembled onto the machine.

Remove three cross head screws just below the hinge on the red collar.

Position the transparense plastic shield into the red collar and secure in place with the three small cross head screws(Fig.7-1). The chuck guard(4) is spring loaded and on a hinge which allows the guard(4) to be moved upwards to expose the chuck(9) for drill installation and

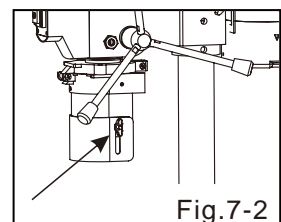
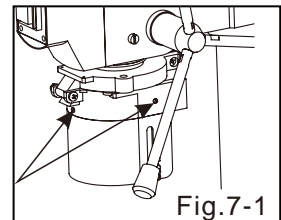

removal. Always return the guard(4) to cover rotating parts. Simply unscrew the wing nuts and the two piece guard will extend vertically up or down. Chuck guard(4) is adjustable to varying depths to give more protection(Fig.7-2).

Fitting the drill depth gauge

Remove the red pointer and uscrew M6 Nut from the bar. Insert the bar into the hole and the hole located in chuck guard(4), then screw the nut, assemble the red pointer in the spindle(Fig.8).

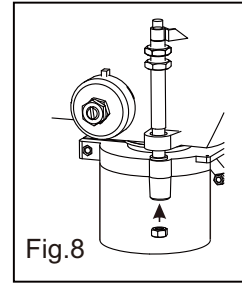

Fitting the 3 jaw chuck

This machine is supplied with a Morse taper stub shaft fitted into the spindle. To fit the chuck(9), clean the protective film from the chuck(9) internal taper and the stub shaft external taper with white spirit. Place the chuck(9) onto the exposed stub shaft. Place a piece of wood onto the drill table. Using the feed handles(3) lower the chuck(9) onto the wood. Gently apply pressure to engage the taper and then let the spindle raise to its upper position(Fig.9).

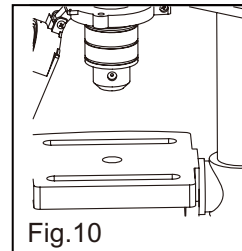
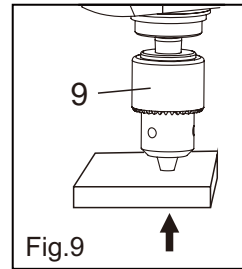

The drill is now fully assembled and secured in position. The following adjustments and setting up instruction must be carried out before connecting the machine to the mains supply.

Connection to the power supply

- > Make sure the on/off switch(11) is in its off position.
- > Connect the plug with a suitable socket.



WARNING! Check the voltage! The voltage must comply with the information on the rating label!

- > Your product is now ready to be used.

Check that you have noted all the following instructions:



- Before starting you must have fully read and understood the entire instruction manual.
- Working with this product is demanding; therefore ensure you are physically and mentally fit to complete the job safely.
- Ensure that you have all the accessories and tools needed for assembly and operation.
- Make sure that you wear suitable personal protective equipment.
- Ensure that no unauthorised people, especially children, and pets are nearby or could enter the working area.

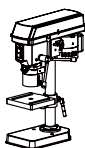

- Ensure that the product is free from damage and that it is not worn.
- Make sure that safety devices and accessories are correctly fixed.
- Double check that all assembly tools have been removed from the product before use.
- Undertake periodic structural checks of this product; do not use it if you have any doubts about its suitability for its intended purpose.



WARNING! For your own and the safety of other people you must read and follow the safety instructions in section "In more detail - Technical and legal information - Safety warnings".



In more detail

Product functions	19
Care and maintenance	24
Trouble shooting	28
Recycling and disposal	30
Guarantee	31
EC declaration of conformity	32

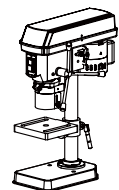

Intended use

This drill press ENB540DBT is designated with a rated input of 350 Watts. This product is used to drill holes in metal and wood.

The product should not be used on masonry and materials that are harmful to health.

This product is intended for private domestic use only, not for any commercial trade use. It must not be used for any purposes other than those described.

Adjusting the table height

To adjust the table(8) height, slacken the support lock(6) at the rear of the table support assembly. Raise table(8) up or down to desired height. When the desired height has been achieved, do not forget to re-secure the support lock(Fig.11).

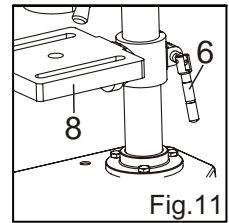

Work table swing 360°

The table(8) may also be swung through 180° either way to allow larger workpieces to be accommodated on the base plate. Simply unclamp the table and manoeuvre either clockwise or anti-clockwise to the rear of the machine.

Tilting the table $\pm 45^\circ$

Locate the securing bolt underneath the table(8). With a suitable socket loosen the bolt. On the table support assembly casting there is a graduated 0 - 45° scale. Set the table(8) to the required angle and retighten the bolt.

Note: The graduated scale is for guidance only we recommend the use of an engineers protractor when setting any angles.

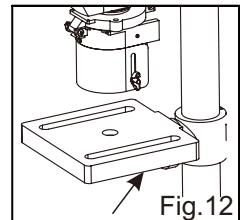

Using a machine vice(vice not supplied)

WARNING: The drill should never be used without the work piece being securely held in a machine vice or clamped directly to the drill table(8). The drill table(8) is designed to accept a variety of machine vice which can be fastened directly to the drill table(8). Always secure the vice to the table(8) with bolts, washers and nuts. If the drill jams into the work piece an unsecured machine vice will spin out of control causing the drill to snap and possibly injure the operator(Fig.13).

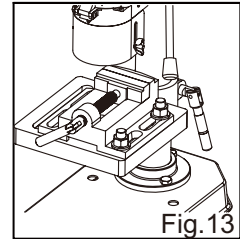

Using the 3 jaw chuck

Select the drill bit required. Open the jaws and insert the drill shank centrally into the chuck(9). Rotate the chuck(9) by hand until the jaws grip the drill bit. The chuck(9) has three holes around the chuck body. Locate the chuck key and using an even torque move from each hole location until all three holes have been covered. Continue with the steady torque until tight. Do not over tighten otherwise you will have difficulty removing the drill bit(Fig.14).

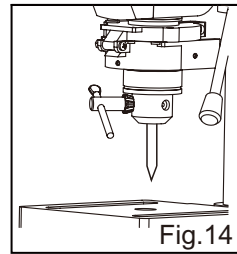

Note: remove the chuck key before use.

Different drill bits and chisels can be used with this product depending on the workpiece material and application required.



WARNING! Always use drill bits according to the intended use! For example, never use a drill bit intended for working on wood for working on stone or vice versa!



Observe the technical requirements of this product (see section "Technical specifications " when purchasing and using drill bits! Some drill bits are very sharp and become hot during use! Handle them carefully! Wear safety gloves when handling drill bits in order to avoid injuries like burns and cuts!

Switching On/off

This machine is fitted with a “No Volts Switch”. In the event of a mains power failure or if the mains plug is removed from the mains supply socket before the machine is switched off, the machine will not restart without warning when the mains supply is restored or the mains plug is re-connected to the mains supply, until the machine is switched ON at the ON/OFF switch(11) fitted to the machine. To start the machine press the green ON button. To stop the machine, press the red OFF button(Fig.15).

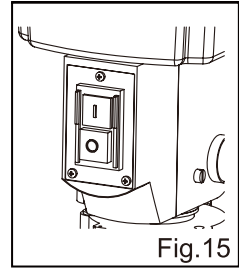

Fig.15

Feed depth adjustment

This facility is useful if a number of uniform depth holes are required in a work piece. Set the work piece to be drilled in your machine vice. Insert the drill required into the chuck(9). Bring the drill bit into contact with the work surface. Using the depth stop nuts and the depth scale, set the depth of hole required, secure the depth stop nuts. The drill will stop at the required depth every time(Fig.16).

NOTE: Always stop feeding while the depth stop nuts stops, otherwise the red plastic collar might be damaged.

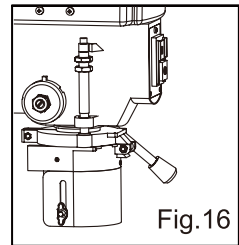

Fig.16

Changing the spindle speed

WARNING: Always ensure that the tool is switched off and unplugged from the power supply before making any adjustments or changing a drill bit. Unscrew the cross head screw securing the pulley guard(1) and lift open the pulley guard(1) to expose the pulley system. Determine the spindle speed required. Identify the pulley arrangement that gives the nearest spindle speed to that required by referring to the drill speed chart(Fig.17).

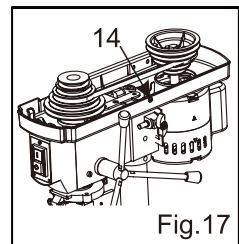
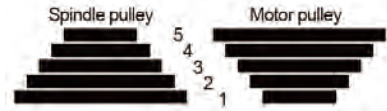

Fig.17

Drill speed chart

Belt setting	Spindle speed (min-1)
1	500
2	890
3	1400
4	1900
5	2500



Slacken the belt tension locking knob. This will allow the tension on the drive belt to be released. The motor assembly is hinged to allow tensioning of the drive belt. To move the drive belt to the desired pulley arrangement push the belt on the largest drive spindle pulley towards the next smallest pulley and at the same time rotate the drive spindle, by hand until the drive belt locates onto the next smallest pulley. Repeat this procedure on the motor pulley until the desired pulley arrangement has been achieved (Fig.18).

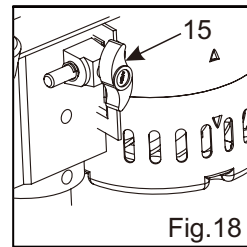

NOTE: Do not cross the belt to give intermediate speeds this will cause damage to the machine.

Belt tension

When the desired pulley arrangement has been achieved tension the drive belt. To check that the correct tension has been achieved, press your finger onto the centre of the drive belt. The drive belt should move approximately 13mm.

Re-tighten the belt tension locking knob (Fig.19).

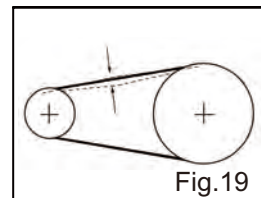

General guidelines for drilling

Always centre punch the position for drilling. A centre punch is a pointed tool that marks the material to be drilled with a small indent. It stops the drill bit moving from the desired position.

Always start by drilling a small pilot hole and gradually progress in drill diameter. When drilling metal, lubricate the drill tip with oil.



NEVER cool with water or water based lubricant otherwise an electric shock could occur. DO NOT use oil when drilling copper or brass. Care should be taken when drilling copper and brass as the drill bit will be prone to jamming.

Small diameter drills require a higher speed and as the drill diameter increases the slower the speed required.

The following drilling speed chart is a guide only and only covers the more common materials, drill diameters and speeds.

Drill speed chart

Duty cycle(S2)

This product has a rated duty cycle of S2. This product must only be run continuously for a maximum of 15 minutes. It must be then switched off and allowed to cool down to room temperature before being run again for 15 minutes.

Drilling speed chart (guide only)						
Material to be drilled						
Drill dia mm	Steel	Cast iron	Gun metal	Aluminium	Plastics	Wood
	Drill speed (min ⁻¹)					
3	2500	2500	2500	2500	2500	2500
4	2500	2500	2500	2500	2500	2500
5	1900	2500	2500	2500	2500	2500
6	1900	2500	2500	2500	2500	2500
7	1400	1900	2500	2500	2500	2500
8	1400	1900	2500	2500	2500	2500
9	890	1400	1900	2500	2500	2500
10	890	1400	1900	1900	2500	2500
11	500	890	1400	1900	1900	2500
12	500	890	1400	1400	1900	1900
13	500	500	890	1400	1400	1900

The golden rules for care

⚠ **WARNING!** Always switch the product off, disconnect it from power supply and let the product cool down before performing inspection, maintenance and cleaning work!

⚠ **WARNING!** Only perform repairs and maintenance work according to these instructions! All further works must be performed by a qualified specialist!

i **NOTE:** Do not use chemical, alkaline, abrasive or other aggressive detergents or disinfectants to clean this product as they might be harmful to its surfaces.

Always wear sturdy gloves when handling or changing bits and cutters as they can be very sharp.

Keep the tools air vents unclogged and clean at all times.

Regularly check to see if any dust or foreign matter has entered the grills near the motor and around the switch. Use a soft brush to remove any accumulated dust.

Wear safety glasses to protect your eyes whilst cleaning.

Re-lubricate all moving parts at regular intervals.

Clean the product with a dry cloth. Use a brush for areas that are hard to reach.

The drill requires very little maintenance apart from keeping all unpainted surfaces coated in light oil. Keep the machine clear of swarf which should be disposed of in a proper manner and not put into household refuse bins.

Always inspect and check the set up and adjustments before using the machine.

⚠ **CAUTION:**Water must never come into contact with the tool.

Quill spring adjustment

⚠ **WARNING:** The quill spring is under extreme tension. The quill spring is located in a metal housing on the opposite side of the feed shaft boss and returns the spindle to its upper most position (Fig.20).

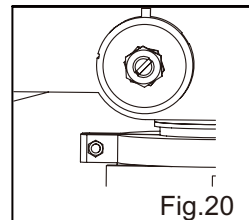

Adjustment is normally only required after many hours of use when it fails to return the spindle to its uppermost position. With the spindle in its uppermost position. It can be seen that the metal cover has a total of three notches cut into

the edge that align with the cast body of the head stock. One of these notches is located on to a cast peg that is part of the main casting.



WARNING: Before slackening the lock nuts ensure that the metal housing is held securely with a suitable grip or wrench. If not held securely the quill spring will fully uncoil.

Eye protection must be worn. Carefully slacken the lock nuts only enough to allow the chrome housing to be pulled out far enough to just clear the cast peg while holding the metal cover with suitable grips. The spring is still under tension and will try to uncoil as soon as it is released so be sure to resist the torque. As soon as the chrome housing is able to clear the cast peg, turn the chrome housing in an anti-clockwise direction until the next notch locates onto the peg. While holding the metal housing in this position tighten the lock nuts. Do not over tighten otherwise you will damage the metal cover.

Spindle play

Locate the spindle play adjustment set screw. Loosen the lock nut and finger tighten the grub screw. Hold the grub screw into position with a hex key and tighten the lock nut (Fig.21).

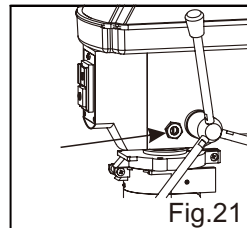

General inspection

Regularly check that all the fixing screws are tight. They may vibrate loose over time.

If the supply cord requires replacing, the task must be carried out by the manufacturer, the manufacturers agent, or an authorised service centre to avoid a safety hazard (Fig.22).

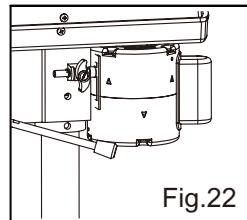

Power cord

If the power cord is damaged, it must be replaced by the manufacturer, its service agent or similarly qualified persons in order to avoid a safety hazard.



WARNING! Check the voltage! The voltage must comply with the information on the rating label!

PLUG REPLACEMENT (UK & IRELAND ONLY)

If you need to replace the fitted plug then follow the instructions below.

IMPORTANT

The wires in the mains lead are colored in accordance with the following code:

BLUE = NEUTRAL

Brown = Live

As the colors of the wires in the mains lead of this appliance may not correspond with the colored markings identifying the terminals in your plug, proceed as follows. The wire which is colored blue must be connected to the terminal which is marked with N. The wire which is colored brown must be connected to the terminal which is marked with L.

Warning:

Never connect live or neutral wires to the earth terminal of the plug. **Only fit an approved 13AMP BS1363/A plug and the correct rated fuse.**

Note: If a moulded plug is fitted and has to be removed take great care in disposing of the plug and severed cable, it must be destroyed to prevent engaging into a socket.

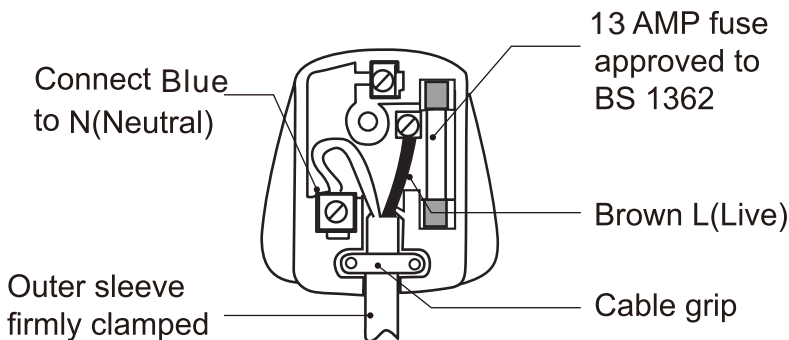

Repair

This product does not contain any parts that can be repaired by the consumer. Contact a qualified specialist to have it checked and repaired.

Storage

1. Clean the product as described above.
2. Store the product and its accessories in a dry, frost-free place.
3. Always store the product in a place that is inaccessible to children. The ideal storage temperature is between 10°C and 30°C.
4. We recommend using the original package for storage or covering the product with a suitable cloth to protect it against dust.

Transportation

1. Switch the product off and disconnect it from power supply before transporting it anywhere.
2. Attach transportation guards, if applicable.
3. The product is heavy. Always carry supporting the motor, column and base plate.
4. Protect the product from any heavy impact or strong vibrations which may occur during transportation in vehicles.
5. Secure the product to prevent it from slipping or falling over.

Trouble shooting

Suspected malfunctions are often due to causes that the users can fix themselves. Therefore check the product using this section. In most cases the problem can be solved quickly.



WARNING! Only perform the steps described within these instructions! All further inspection, maintenance and repair work must be performed by an authorised service centre or a similarly qualified specialist if you cannot solve the problem yourself!

Problem	Possible cause	Solution
1.Noisy operation	1.1 Incorrect belt tension 1.2 loose spindle pulley 1.3 loose motor pulley	1.1 Adjust tension 1.2 Tighten the pulley insert nut 1.3 Tighten the screws
2.Drill bit gets excessively hot	2.1 Incorrect speed 2.2 Chips not coming out of hole 2.3 Dull drill bit 2.4 Feeding too slow 2.5 Drill bit not being allowed to cool down or not lubricated in use	2.1 Adjust the speed 2.2 Retract drill bit frequently to clear chips 2.3 Resharpen drill bit 2.4 Feed fast enough, allow drill bit to cut 2.5 Lubricate drill bit when cutting. Follow S2 duty cycle time.
3.Wood splinters on underside	3. No back-up material under workpiece	3. Use back-up material
4. Drill bit binds	4.1 Not supported or clamped properly 4.2 Improper belt tension	4.1 Support workpiece or clamp workpiece 4.2 Adjust tension
5. Excessive drill bit runout or wobble	5.1 Bent drill bit 5.2 Worn spindle bearing 5.3 Chuck not properly installed	5.1 Change drill bit 5.2 Change bearing 5.3 Install chuck properly

Problem	Possible cause	Solution
6. Quill returns too slow or too fast	6.Spring has improper tension	6. Adjust spring tension
7.Chuck falls off when attached to spindle, falls off when trying to install it	7. Dirty, grease, or oil on the tapered inside surface of chuck or on the spindles tapered surface.	7. Clean it
8.Pulley sliding	8. Belt is not tight	8. Tighten the belt

Recycling and disposal



Waste electrical products should not be disposed of with household waste. Please recycle where facilities exist. Check with your local authority or local store for recycling advice.



GUARANTEE

This ENERGER product carries a guarantee of 12 months.

If your product develops a fault within this period, you should, in the first instance contact the retailer where the item was purchased.

This guarantee specifically excludes losses caused due to:

- Fair wear and tear
 - Misuse or abuse
 - Lack of routine maintenance
 - Failure of consumable items
 - Accidental damage
 - Cosmetic damage
 - Failure to follow manufacturer's guidelines
 - Loss of use of the goods
- This guarantee does not affect your statutory rights.

This guarantee is only valid in the UK. For any enquiries relating to the guarantee please refer to your retailer.

ENVIRONMENTAL PROTECTION



This product marked with the selective sorting symbol on waste electrical and electronic equipment. This means that this product should not be disposed of with household waste but must be supported by a collection system in accordance with Directive 2002/96/EC. It will then be recycled or dismantled to minimize impacts on the environment, electrical and electronic products are potentially hazardous to the environment and human health due to the presence of hazardous substances.

**Declaration of Conformity**

We, Importer
Powersmith (UK) LTD.
Trade house, Mead Avenue, BA22 8RT

Declare that the product:
Designation: DRILL PRESS 350W
Model: ENB540DBT

Complies with the following Directives:
2004/108/EC Electromagnetic Compatibility Directive
2006/42/EC Machinery Directive
2006/95/EC Low Voltage Directive
2011/65/EU Restrictions of the Use of Certain Hazardous Substances in
Electrical and Electronic Equipment
2002/96/EC and 2003/108/EC Waste Electrical and Electronic Equipment
(WEEE)

Standards and technical specifications referred to:
EN 61029-1:2009+A11:2010
EN 55014-1:2006/+A1+A2:2009
EN 55014-2:1997/A1:2001/+A2:2008
EN 61000-3-2:2006/+A1:2009/+A2:2009
EN61000-3-3:2008

Authorised Signatory and technical file holder

Date : 07/09/2013

Signature: P. Harries



Name / title: Peter Harries / Quality Manager
Powersmith (UK) LTD. Trade House , Mead Avenue , BA22 8RT



Powersmith (UK) LTD.
Trade House Mead Avenue, BA22 8RT
