

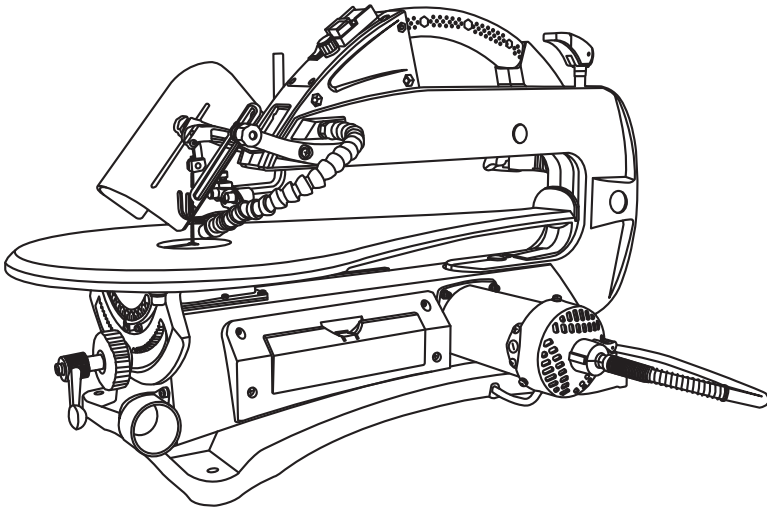

# 240W Scroll Saw



## TTB545SSW

Barcode: 5052931253661



**WARNING! Read the instructions before using the product!**

# TITAN®

**Congratulations on your purchase of a TITAN power tool from TITAN Power Tools (UK) Ltd. We want you to continue getting the best performance from it so this handbook includes information on safety, handling and care. Please retain this handbook in case you need to refer to any of the information in the future. Your TITAN power tool comes with a 2 year guarantee, so should it develop a fault within this period contact your retailer.**

## **GUARANTEE**



This TITAN product carries a 2 year guarantee. If your product develops a fault within this period, you should, in the first instance contact the retailer where the item was purchased.

This guarantee specifically excludes losses caused due to:

- Fair wear and tear
- Misuse or abuse
- Lack of routine maintenance
- Failure of consumable items (such as batteries)
- Accidental damage
- Cosmetic damage
- Failure to follow manufacturer's guidelines
- Loss of use of the goods

This guarantee does not affect your statutory rights. This guarantee is only valid in the UK.

**240W SCROLL SAW**

**TTB545SSW**

# Let's get started...

These instructions are for your safety. Please read through them thoroughly before use and retain them for future reference.



## Getting **started...** 03

<b>Your product</b>	04
<b>Technical and legal information</b>	05
<b>Before you start</b>	12



## In more **detail...** 20

<b>Product functions</b>	21
<b>Care and maintenance</b>	27
<b>Trouble shooting</b>	31
<b>Recycling and disposal</b>	33
<b>EC declaration of conformity</b>	34

Your product

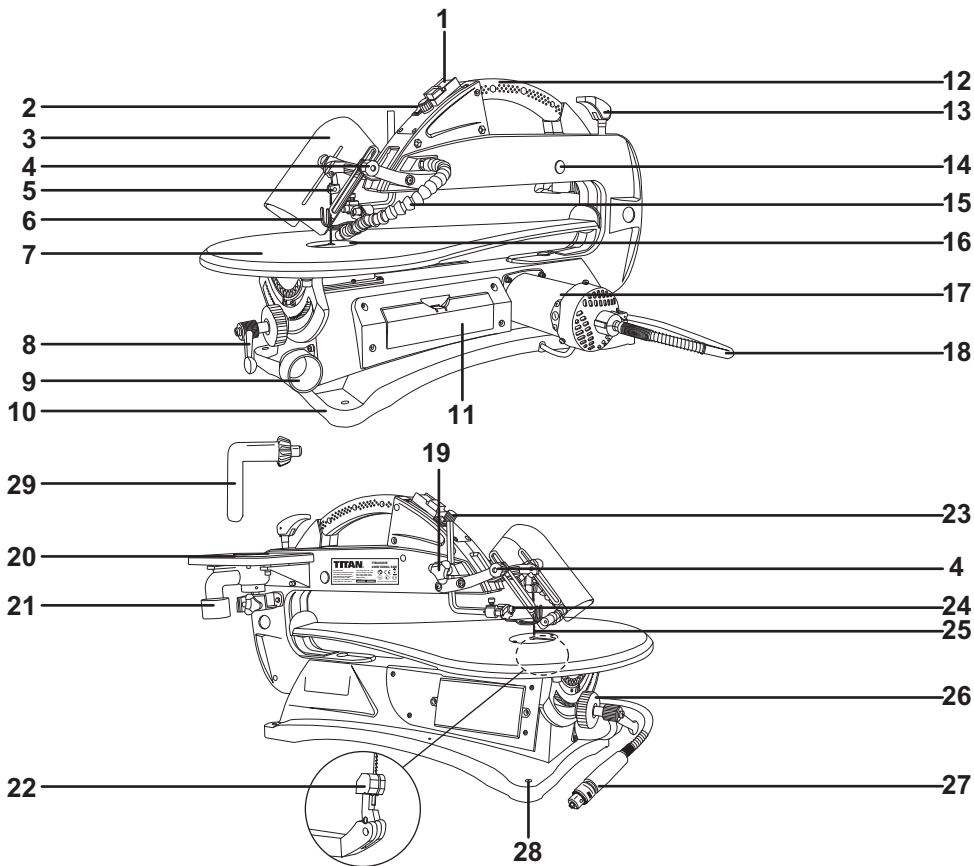

- |                         |                              |                              |
|-------------------------|------------------------------|------------------------------|
| 1. On/off switch        | 11. Storage compartment      | 21. Rotary tool dust port    |
| 2. Switch for LED light | 12. Carry handle             | 22. Lower blade holder       |
| 3. Protective guard     | 13. Blade tension lock lever | 23. Speed control knob       |
| 4. Knob for blade guard | 14. Rubber bearing cover     | 24. Tilting adjustment screw |
| 5. Upper blade holder   | 15. Dust blower and light    | 25. Saw blade                |
| 6. Blade guard foot     | 16. Table insert             | 26. Bevel adjustment knob    |
| 7. Work table           | 17. Motor                    | 27. Rotary tool              |
| 8. Bevel lock handle    | 18. Rotary tool cable        | 28. Mounting hole            |
| 9. Sawdust port         | 19. Height adjustment knob   | 29. Chuck key                |
| 10. Base                | 20. Rotary table             |                              |

## Technical specifications

### General

- > **Input Voltage** : 230-240V~50Hz
- > **Power Input** : 240W S6 60% 10min
- > **Saw Blade Speed** : 400-1600min<sup>-1</sup>
- > **Saw Blade Size** : 127mm x 2.6mm
- > **Max. Cutting Depth** : 51mm
- > **Max. Cutting Width** : 457mm
- > **Grind Head Speed** : 1200-4500min<sup>-1</sup>
- > **Drilling Capacity** : ≤ ø6.35mm
- > **Rotary Tools Fastening System** : Chuck key
- > **Working Table Size** : 625 x 330mm
- > **Rotary Table Size** : 136 x 180mm
- > **Table Tilting Range** : - 45° to + 45°
- > **Net Weight** : 21.5kg

### VIBRATION

The European Physical Agents (Vibration) Directive has been brought in to help reduce hand arm vibration syndrome injuries to power tool users. The directive requires power tool manufacturers and suppliers to provide indicative vibration test results to enable users to make informed decisions as to the period of time a power tool can be used safely on a daily basis and the choice of tool.

Further Advice can be found at [www.hse.gov.uk](http://www.hse.gov.uk)

<b>Sound level according to EN 61029</b>	Sound pressure level $L_{pA}$ : 77.5dB(A)
	Sound power level $L_{WA}$ : 85dB(A)
	Uncertainty $K_{pA}$ , $K_{WA}$ : 3dB(A)
<b>Vibration total values (triax vector sum) determined according to EN 61029:</b>	
<b>Work mode description 1 (if required by the relevant Part 2)</b>	Vibration emission value $a_n$ = 3.0m/s <sup>2</sup>
	Uncertainty $K$ = 1.5m/s <sup>2</sup>

The declared vibration emission value should be used as a minimum level and should be used with the current guidance on vibration.

Calculating the actual period of the actual period off use can be difficult and the HSE website has further information.

The declared vibration emission been measured in accordance with a standardised test stated above and may be used to compare one tool with another.

The declared vibration emission value may also be used in a preliminary assessment of exposure.

 **Warning!** The vibration emission value during actual use of the power tool can differ from the declared value depending on the ways in which the tool is used dependant on the following examples and other variations on how the tool is used:

How the tool is used and the materials being cut or drilled.

The tool being in good condition and well maintained.

The use the correct accessory for the tool and ensuring it is sharp and in good condition.

The tightness of the grip on the handles.

And the tool is being used as intended by its design and these instructions.

### **This tool may cause hand-arm vibration syndrome if its use is not adequately managed**

 **Warning!** identify safety measures to protect the operator that are based on an estimation of exposure in the actual conditions of use (taking account of all parts of the operating cycle such as the times when the tool is switched off and when it is running idle in addition to the trigger time).Note The use of other tools will reduce the users' total working period on this tool.

Helping to minimise your vibration exposure risk.

ALWAYS use sharp chisels, drills and blades.

Maintain this tool in accordance with these instructions and keep well lubricated (where appropriate)

Avoid using tools in temperatures of 10°C or less.

Plan your work schedule to spread any high vibration tool use across a number of days.

Health Surveillance

All employees should be part of an employer's health surveillance scheme to help identify any vibration related diseases at an early stage, prevent disease progression and help employees stay in work.

### **Important note**

Remove the mains plug from socket before carrying out any adjustment or servicing.

Ensure your mains supply voltage is the same as your tool rating plate voltage.

## Symbols

On the product, the rating label and within these instructions you will find among others the following symbols and abbreviations.

Familiarise yourself with them to reduce hazards like personal injuries and damage to property.

V~	Volt	Hz	Hertz
W	Input power	kg	Kilogram
m/min	Metres per minute	dB(A)	Decibel (A-rated)
min <sup>-1</sup>	Per minute	∅	Diameter
yyWxx	Manufacturing date code; year of manufacturing (20yy) and week of manufacturing (Wxx);		



Caution / Warning.



Wear hearing protection.



Read the instruction manual.



Wear eye protection.



Wear gloves.



Wear respiratory protection.



Switch the product off and disconnect it from the power supply before assembly, cleaning, adjustments, maintenance, storage and transportation.



The product complies with the applicable European directives and an evaluation method of conformity for these directives was done.



WEEE symbol. Waste electrical products should not be disposed of with household waste. Please recycle where facilities exist. Check with your Local Authority or local store for recycling advice.

## Safety warnings

### GENERAL SAFETY INSTRUCTIONS



**WARNING!** To ensure safe operation when using your scroll saw, make sure you follow basic safety principles to reduce risk of personal injury, electric shock and fire. Please read the following instructions prior to operating this product and keep for future use.

**SAVE THESE INSTRUCTIONS****1. Keep the work area clean.**

- > Cluttered and dark areas invite accidents.

**2. Consider work area environment.**

- > Do not expose power tools to rain. Do not use power tools in damp or wet locations. Keep the work area well lit. Do not use tools in the presence of flammable liquids or gases.

**3. Guard against electric shock.**

- > Avoid body contact with earthed or grounded surfaces (e.g. pipes, radiators, ranges, refrigerators).

**4. Keep children away.**

- > Do not let persons, especially children, not involved in the work touch the tool or the extension cord and keep them away from the work area.

**5. Store idle tools.**

- > When not in use, tools should be stored in a dry, high or locked up place, out of reach of children.

**6. Do not force the tool.**

- > It will do the job better and safer at the rate for which it was intended.

**7. Use the right tool.**

- > Do not force small tools to do the job of a heavy-duty tool. Do not use tools for purposes not intended, for example, do not use circular saws to cut tree limbs or logs.

**8. Dress properly.**

- > Do not wear loose clothing or jewellery, they can be caught in moving parts. Non-skid footwear are recommended when working outdoors. Wear protective hair covering to contain long hair.

**9. Use protective equipment.**

- > Use safety glasses. Use face or dust mask if working operations create dust.

**10. Connect dust extraction equipment.**

- > If the tool is provided for the connection of dust extraction and collecting equipment, ensure these are connected and properly used.

**11. Do not abuse the cord.**

- > Never yank the tool to disconnect it from the socket. Keep the cord away from heat, oil and sharp edges.

**12. Secure work.**

- > Where possible use clamps or a vice to hold the work. It is safer than using your hand.

**13. Do not overreach.**

- > Keep proper footing and balance at all times.

**14. Maintain tool with care.**



- > Keep cutting tools sharp and clean for better and safer performance. Follow instructions for lubrication and changing accessories. Inspect tool cord periodically and if damaged have them replaced by an authorised service facility. Inspect extension cords periodically and replace if damaged. Keep handles dry, clean and free of oil or grease.

#### **15. Disconnect tools.**

- > When not in use, before servicing and when changing accessories such as blades, bits and cutters, disconnect tools from the power supply.

#### **16. Remove adjusting keys and wrenches.**

- > From the habit of checking to see that keys and adjusting wrenches are removed from the tool before turning it on.

#### **17. Avoid unintentional starting.**

- > Ensure switch is in the "off" when plugging in.

#### **18. Use outdoor extension leads.**

- > When tool is used outdoors, use only extension cords intended for outdoor use and so marked.

#### **19. Stay alert.**

- > Watch what you are doing. Use common sense. Do not operate tool when you are tired.

#### **20. Check damaged parts.**

- > Before further use of the tool, it should be carefully checked to determine that it will operate properly and perform its intended function. Check for alignment of moving parts, binding of moving parts, breakage of parts, mounting and any other conditions that may affect its operation. A guard or other part that is damaged should be properly repaired or replaced by an authorised service centre unless otherwise indicated in this instruction manual. Have defective switches replaced by an authorised service facility. Do not use the tool if the switch does not turn it on and off.

#### **21. Warning.**

- > The using of any accessory or attachment other than those recommended in this instruction manual may present a risk of personal injury.

#### **22. Have your tools repaired by qualified person.**

- > This electrical tool complies with the relevant safety requirements. Repairs should only be carried out by qualified persons using original spare parts, otherwise this may result in considerable danger to the user.

### **HEALTH ADVICE**



**Warning!** When drilling, sanding, sawing or grinding, dust particles will be produced. In some instances, depending on the materials you are working with, this dust can be particularly harmful to you (e.g. lead from old gloss paint).

You are advised to consider the risks associated with the materials you are working with and to reduce the risk of exposure. You should:

- Work in a well-ventilated area.
- Work with approved safety equipment, such as those dust masks that are specially designed to filter microscopic particles.

### ADDITIONAL SAFETY INSTRUCTIONS FOR YOUR TOOLS



**WARNING:** Do not operate the scroll saw until it is assembled, and you have read and understood the following instructions and the warning labels on the scroll saw.

#### Before operating

- > Check for proper assembly and proper alignment of moving parts. Understand the function and proper use of the ON/OFF switch.
- > Understand the function and proper use of the ON/OFF switch.
- > Know the condition of the scroll saw. If any part is missing, bent, or does not operate properly, replace the component before you use the scroll saw.
- > Determine the type of work you are going to be doing. Properly protect your body including your eyes, hands, face, and ears.
- > To avoid injury caused by pieces thrown from accessories, use only recommended accessories designed for this saw. Follow the instructions supplied with the accessory. The use of improper accessories may cause risk of injury.
- > To avoid contact with rotating equipment:
  - Do not position your fingers where they could contact the blade if the workpiece should unexpectedly shift or your hand should slip.
  - Do not cut a workpiece too small to be held safely.
  - Do not reach under the scroll saw table when the motor is running.
  - Do not wear loose clothing or jewelry. Roll long sleeves above the elbow. Tie back long hair.
- > To avoid injury from accidental starting of the scroll saw:
  - Make sure the switch is OFF and unplug the power cord from the electric outlet before changing the blade, performing maintenance or making adjustments.
  - Make sure the switch is OFF before plugging in the power cord to an electric outlet.
- > To avoid injury from a fire hazard, do not operate the scroll saw near flammable liquids, vapors or gases.
- > To avoid back injury:
  - Obtain help when it is necessary to raise the scroll saw more than 10 inches.

Bend your knees when lifting the scroll saw.

- > Carry the scroll saw by its base. Do not move the scroll saw by pulling on the powercord. Pulling on the power cord could cause damage to the insulation or the wire connections resulting in electric shock or fire.

### When operating the scroll saw



**WARNING:** Use the rotary tool for sanding and grinding applications only. This product is not recommended for drilling applications.

- > To avoid injury from unexpected scroll saw movement:
  - Use the scroll saw on a firm level surface with adequate space for handling and supporting the workpiece.
  - Be sure the scroll saw cannot move when operated. Secure the scroll saw to a workbench or table with wood screws or bolts with washers and nuts.
- > Before moving the scroll saw, unplug the power cord from the electrical outlet.
- > To avoid injury from kickback:
  - Hold the workpiece firmly against the tabletop.
  - Do not feed the workpiece too fast while cutting. Only feed the workpiece at the rate the saw will cut.
  - Install the blade with the teeth pointing downward.
  - Do not start the saw with the workpiece pressing against the blade. Slowly feed the workpiece into the moving blade.
  - Use caution when cutting round or irregularly shaped work pieces. Round items will roll and irregularly shaped work pieces can pinch the blade.
- > To avoid injury when operating the scroll saw:
  - If you are not thoroughly familiar with the operation of scroll saws, obtain advice from a qualified person.
  - Before starting the saw, make sure the blade tension is correct. Recheck and adjust tension as needed.
  - Make sure the table is locked into position before starting the saw.
  - Do not use dull or bent blades.
  - When cutting a large workpiece, make sure the material is supported at the table height.
  - Turn the saw OFF and unplug the power cord if the blade jams in the workpiece while being backed out. This condition is usually caused by sawdust clogging the line you are cutting. If this happens, turn OFF the scroll saw and unplug the power cord. Wedge open the workpiece and back out the blade.
  - Do not use if blade guard is damaged or missing.
  - Do not clear away cut-off pieces until blade has stopped and the saw is turned off.

## Unpack

- > Unpack all parts and lay them on a flat, stable surface.
- > Remove all packing materials and shipping devices if applicable.
- > Make sure the delivery contents are complete and free of any damage. If you find that parts are missing or show damage do not use the product but contact your dealer. Using an incomplete or damaged product represents a hazard to people and property.
- > Ensure that you have all the accessories and tools needed for assembly and operation. This also includes suitable personal protective equipment.



**CAUTION!** Do not lift the saw by the arm that holds the blade. The saw will be damaged.

## You will need

(items not supplied)

- > Suitable personal protective equipment
- > Phillips screwdriver
- > Combination square
- > 12mm Spanner
- > Small C-clamps (2pcs)
- > Ruler or measuring tape
- > 12" Straight scrap of wood (thickness to match workpiece)

(items supplied)

- > 5mm Hex key (1pc)
- > Chuck key (1pc)



**WARNING!** Do not connect to power supply until assembly is complete. Failure to comply could result in accidental starting and possible serious injury.

## Mounting your machine

Your scroll saw is provided with 4 mounting holes (28), and it is recommended that this tool is securely mounted onto a robust workbench.

- > Insert the bolts 8 x 50mm (30), spring washers M8 (31), rubber feet (32), flat washers (33) and nut (34) into the holes in turns as shown in Fig. 1.
- > Then tighten the 4 bolts (30) with 12mm spanner (not supplied).

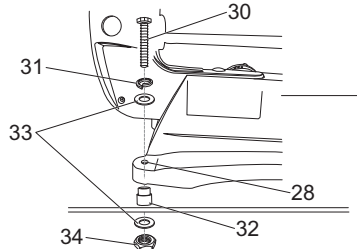

Fig. 1

## Storage compartment

A storage location (35) for small accessories.

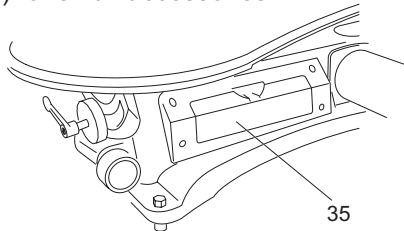

Fig. 2

## Align the bevel indicator

The bevel indicator has been factory adjusted, it should be rechecked prior to use for best operation.

- > Remove the blade guard foot (6) using a hex key to loosen the screw (24) with 5mm hex key.
- > Loosen the table bevel lock handle (8) and turn the table adjustment knob (26) to move the table until it is approximately at a right angle to the blade.
- > Use a combination square (36) (not provided) to set the table exactly 90° to the blade (25). If there is space between the square and the blade adjust the table angle until the space is closed.
- > Tighten the table bevel lock handle (8) to prevent movement.

- > Loosen the screw (37) holding the bevel scale pointer and position pointer to 0°. Tighten the screw.
- > Attach the blade guard foot (6) and tighten the screw (24) with 5mm hex key.

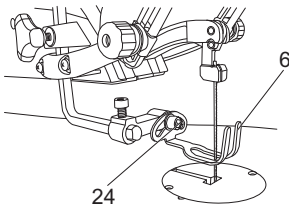

Fig. 3

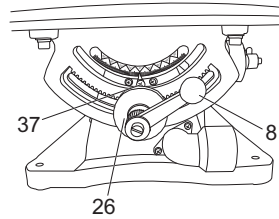

Fig. 4

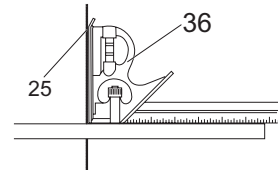

Fig. 5



**WARNING:** to reduce the risk of injury:

- When carrying the saw, hold it close to your body to avoid injury to your back. Bend your knees when lifting the saw.
- Carry the saw by the base. Do not carry the saw by the power cord.
- Secure the saw in a position where people cannot stand, sit or walk behind it. Debris thrown from the saw could injure people standing, sitting or walking behind it.
- Secure the saw on a firm, level surface where the saw cannot rock and there is adequate room for handling and properly supporting the workpiece.

## Blade guard foot adjustment

When cutting at angles, the blade guard foot should be adjusted so it is parallel to the table and rests flat above the workpiece.

- > To adjust, loosen the screw (24), tilt the foot (6) so it is parallel to the table, and tighten the screw.
- > Loosen the height adjustment knob (19) to raise or lower the foot until it just rests on top of the workpiece. Tighten the knob.
- > Loosen the horizontal adjustment screw (38) with hex key 5mm, then move the foot forward or backward as needed.

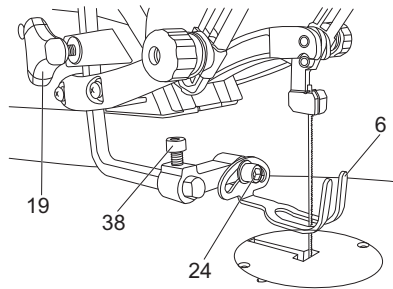

Fig. 6

## Sawdust collection port

This scroll saw allows a hose or vacuum accessory (not provided) to be connected to the sawdust port (9) at the front of the saw and to the dust port (21) under the rotary tool table (20), if installed.

If excessive sawdust buildup occurs inside the base, use a wet/dry vacuum cleaner or manually remove sawdust. This will keep your saw cutting efficiently.

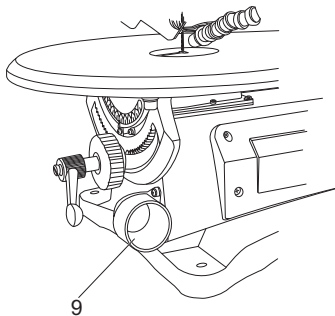

Fig. 7

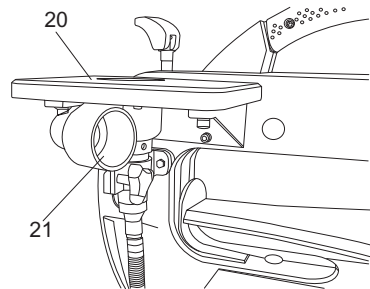

Fig. 8

## Adjusting the dust blower/light

For best results, the dust blower tube should be adjusted to direct air and light at the blade and workpiece.

## Blade selection

This scroll saw accepts 5" length pin-end and pinless blades, with a wide variety of blade thicknesses and widths. The type of material and intricacies of cutting operations will determine the number of teeth per inch. Always select the narrowest blades for intricate (tight radius and curves) curve cutting and the widest blades for straight and large curve cutting operations. The following table represents suggestions for various materials. When purchasing blades, refer to the back of the package for best use of blades on various materials. Use this table as an example, but practice and your own personal preference will be the best selection method.

When choosing a blade, use very fine, narrow blades to scroll cut in thin wood 1/4" thick or less. Use wider blades for thicker materials but this will reduce the ability to cut tight curves.

**i** **NOTE:** Thinner blades will have more possibilities for blade deflection when cutting angles are not perpendicular to the table.

Teeth/inch TPI	Blade width Inch	Blade thickness Inch	Blade/SPM	Material cut
10-15	0.110	0.018	500-1200	Medium turns on 1/4" to 1-3/4" wood, soft metal, hardwood
15-28	0.055-0.110	0.010-0.018	800-1700	Small turns on 1/8" to 1-1/2" wood, soft metal, hardwood
30-48	0.024-0.041	0.012-0.019	Varies	Non-ferrous metal/hardwoods using very slow speeds

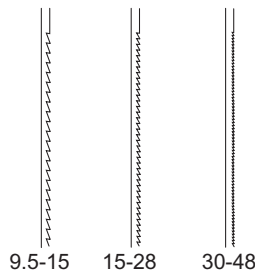

Fig. 9



## Blade Care

To maximize the life of your scroll saw blades:

- > Do not bend blades when installing.
- > Always set proper blade tension.
- > Use the right blade (see instructions on replacement blade packaging for proper use.)
- > Feed the workpiece correctly into the blade.
- > Use thin blades for intricate cutting.



**CAUTION:** Any and all servicing should be performed by a qualified service center.

## Blade removal and installation



**WARNING:** To prevent personal injury, always turn saw OFF and disconnect the plug from the power source before changing blades or making adjustments.

Pin-end blades are thicker for stability and for faster assembly. They provide faster cutting on a variety of materials.



**NOTE:** When installing pin-end blades, the slot on the blade holder must be slightly wider than the thickness of the blade. After the blade is installed, the blade tension mechanism will keep it in place.

- > Loosen the blade tension by raising the blade tension lock lever (13).
- > To remove a blade:  
Lift the blade (25) out by pulling forward on blade (25), then lifting the blade (25) from the upper blade holder (5) and lower blade holder (22). Slight downward pressure against the upper arm (39) may be helpful when removing blade from upper blade holder (5).



**CAUTION:** Install the blade with the teeth pointed downward.

> Install a blade:

- Hook a blade (25) in the recess of the lower blade holder (22).
- Press down on the upper arm (39) and insert the blade into the slot on the upper holder (5).
- Lower the blade tension lock lever (13). Make sure the blade is properly located in the blade holders.

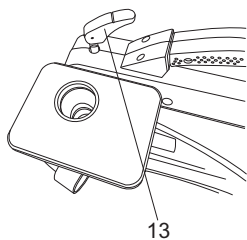

Fig. 10

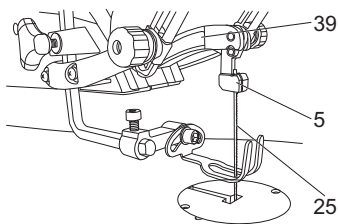

Fig. 11

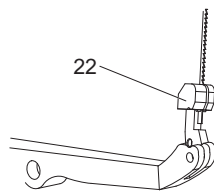

Fig. 12

## Connect the rotary tool to the saw



**WARNING:** Remove the saw blade before installing and/or using the rotary tool.

The rotary tool can be used as a handheld or stationary device. The rotary tool connects to the motor and is operated using the ON/OFF switch and variable speed dial on the saw.

- > Open the latch (40) on the rotary tool coupler (40) of the rotary tool (27).
- > Insert the inner cable into the opening (42) at the end of the motor fitting.
- > Place the coupler (41) over the motor fitting. Turn the coupler to ensure a good fit, and close the latch (40).

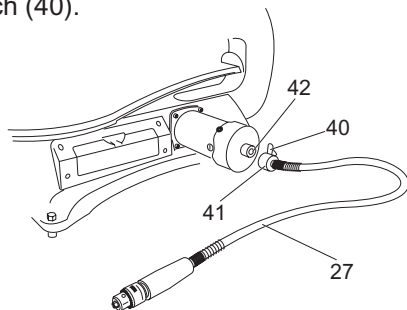

Fig. 13

## Attach the tool to the support bracket

Use this procedure to use the rotary tool as a stationary device.

- > Loosen the knob (43) on the rotary clamp.
- > Insert the rotary tool (27) through the clamp and the opening in the rotary table (20).
- > Tighten the knob (43) to secure the rotary tool in the clamp.
- > Place the rotary table insert (44) in the opening on the rotary table.

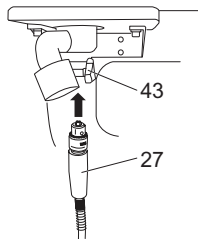

Fig. 14

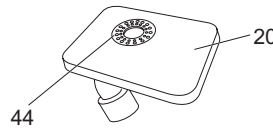

Fig. 15

## Install rotary tools



**WARNING:** Use the rotary tool for sanding and grinding applications only. This product is not recommended for drilling applications.

- > Place the chuck key (29) into the side keyhole of the chuck, meshing the key with the gear teeth.
- > Turn the chuck key counterclockwise to open the chuck jaws.
- > Insert a rotary tool (45) (not provided) into the chuck far enough to obtain maximum gripping of the chuck jaws.
- > Center the rotary tool in the chuck jaws.
- > Tighten the chuck jaws using the chuck key to ensure that the tool will not slip while drilling.
- > Remove the chuck key (29).

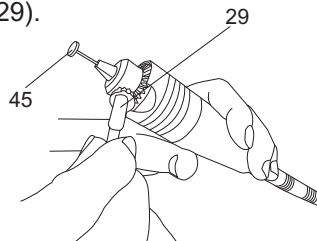

Fig. 16



## In more detail...

<b>Product functions</b>	21
<b>Care and maintenance</b>	27
<b>Trouble shooting</b>	31
<b>Recycling and disposal</b>	33
<b>EC declaration of conformity</b>	34

In more detail...

## Recommendations for cutting

A scroll saw is basically a curve-cutting machine. It can also be used for straight cutting and beveling or angle cutting operations. Please read and understand the following items before attempting to use the saw.

- > When feeding the workpiece into the blade do not force it against the blade. This could cause blade deflection. Allow the saw to cut the material by guiding the workpiece into the blade as it cuts.
- > The blade teeth cut material **ONLY** on the down stroke.
- > Guide the wood into the blade slowly because the teeth of the blade are very small and remove wood only on the down stroke.
- > There is a learning curve for each person using this saw. During that period of time it is expected that some blades will break until you learn how to use the saw.
- > Best results are achieved when cutting wood one inch thick or less.
- > When cutting wood thicker than one inch, guide the wood very, very slowly into the blade and take extra care not to bend or twist the blade while cutting in order to maximize blade life.
- > Teeth on scroll saw blades wear out and the blades must be replaced frequently for best cutting results. Scroll saw blades generally stay sharp for 1/2 hour to 2 hours of cutting.
- > To get accurate cuts, be prepared to compensate for the blade's tendency to follow the wood grain as you are cutting.
- > This scroll saw is primarily designed to cut wood or wood products. For cutting precious and non-ferrous metals, the variable control switch must be set at very slow speeds.
- > When choosing a blade, use very fine, narrow blades to scroll cut in thin wood 1/4" thick or less. Use wider blades for thicker materials but this will reduce the ability to cut tight curves.
- > Blades wear faster when cutting plywood or very abrasive particle board. Angle cutting in hardwoods wears blades down faster.



**NOTE:** The saw is primarily intended for woodworking. In this case choice a suitable device that you can avoid inhaling the dust. Insert the nozzle to a standard vacuum hose.

## LED Light switch

- > To turn on the light, press the light switch (2) to the ON (I) position.
- > To turn OFF the light, press the light switch (2) to the OFF (O) position.

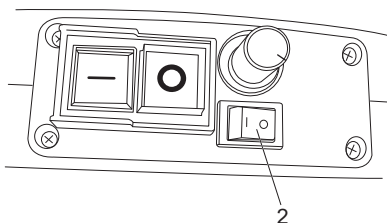

Fig. 17

## ON/OFF switch and speed control knob

Always wait for the saw or rotary to come to a complete stop before restarting.

- > To turn the saw or rotary on, press the switch (1) to the ON (I) position.
- > Turn the variable speed knob (23) to adjust the blade speed or rotary speed to the desired setting. Turning the control knob clockwise increases speed; turning it counterclockwise reduces speed.
- > To turn the saw off, press the switch (1) to the OFF (O) position.



**WARNING:** To avoid injury from accidental start-ups, always turn the switch OFF and unplug the scroll saw before moving the tool, replacing the blade or making adjustments.

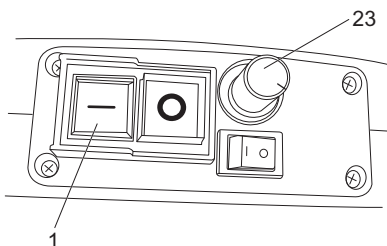

Fig. 18

## Freehand cutting

- > Lay out desired design, or secure design to the workpiece.
- > Raise the blade guard foot (6) by loosening the height adjustment knob (19).
- > Position the workpiece against the blade and place the blade guard foot against the top surface of the workpiece.
- > Secure the blade guard foot (6) by tightening the height adjustment knob (19).
- > Remove the workpiece from the blade prior to turning the scroll saw ON.



**CAUTION:** In order to avoid uncontrollable lifting of the workpiece and to reduce blade breakage, do not turn the switch on while the workpiece is against the blade.

- > Slowly feed the workpiece into the blade by guiding and pressing the workpiece down against the table.



**CAUTION:** Do not force the leading edge of the workpiece into the blade. The blade will deflect, reducing accuracy of cut, and may break.

- > When the cut is complete, move the trailing edge of the workpiece beyond the blade guard foot. Turn the switch OFF.

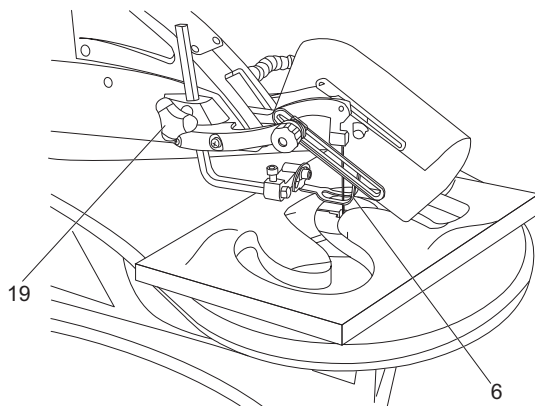

Fig. 19

## Angle cutting (bevel cutting)

- > Layout or secure design to workpiece.
- > Move the blade guard foot to the highest position by loosening the height adjustment knob (19). Retighten.
- > Tilt the table to the desired angle by loosening the table bevel lock (8) and turning the bevel adjustment knob (26) to move the table to the proper angle using the degree scale and the pointer (46).
- > Tighten the table bevel lock handle (8).
- > Loosen the blade guard screw, and tilt the blade guard to the same angle as the table. Retighten the blade guard screw. See Hold down clamp adjustment.
- > Position the workpiece on the right side of the blade. Lower the blade guard foot against the surface by loosening the height adjustment knob. Retighten.
- > Follow steps 5-7 under Freehand cutting.

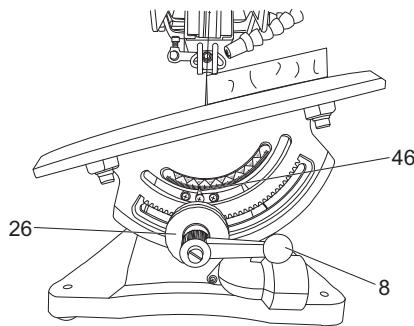

Fig. 20

## Interior cutting

- > Lay out the design on the workpiece. Drill a 1/4" hole in the workpiece.
- > Remove the blade. See Blade removal and installation.
- > Place the workpiece on the saw table with the hole in the workpiece over the access hole in the table.
- > Install a blade through the hole in the workpiece.
- > Follow steps 3-7, under Freehand cutting.
- > When finished making the interior scroll cuts simply turn the scroll saw OFF. Unplug the saw before removing the blade from the blade holder. Remove the workpiece from the table.



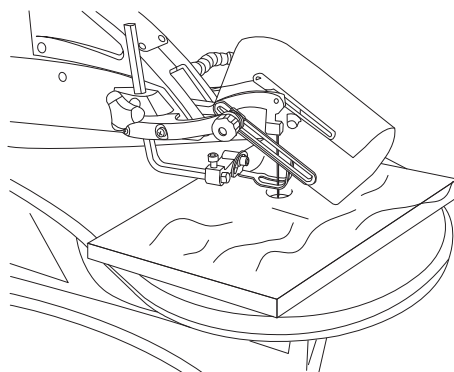

Fig. 20

## Rip or straight line cutting

- > Raise the blade guard foot (6) by loosening the height adjustment knob (19).
- > Measure from the tip of the blade to the desired distance. Position the straight edge parallel to the blade at that distance.
- > Clamp the straight edge to the table.
- > Recheck your measurements using the workpiece to be cut and make sure the straight edge is secure.
- > Position the workpiece against the blade and place the blade guard foot against the top surface of the workpiece.
- > Secure the blade guard foot in place by tightening the height adjustment knob.
- > Remove the workpiece from the blade prior to turning the scroll saw ON.



**CAUTION:** In order to avoid uncontrollable lifting of the workpiece and reduce blade breakage, do not turn the switch on while the workpiece is against the blade.

- > Position the workpiece against the straight edge prior to touching the leading edge of the workpiece against the blade.
- > Slowly feed the workpiece into the blade, guiding the workpiece against the straight edge and pressing the workpiece down against the table.



**CAUTION:** Do not force the leading edge of the workpiece into the blade. The blade will deflect, reducing accuracy of cut, and may break.

- > When the cut is complete, move the trailing edge of the workpiece beyond the blade guard foot. Turn the switch OFF.

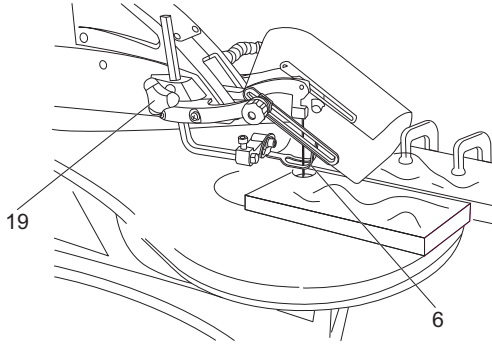

Fig. 21

## The golden rules for care



**WARNING!** Always switch the product off, disconnect it from the power supply and let the product cool down before performing inspection, maintenance and cleaning work!

- > Keep the product clean. Remove debris from it after each use and before storage.
- > Regular and proper cleaning will help ensure safe use and prolong the life of the product.
- > Inspect the product before each use for worn and damaged parts. Do not operate it if you find broken and worn parts.



**WARNING!** Only perform repairs and maintenance work according to these instructions! All further works must be performed by a qualified specialist!

## General operation

- > To ensure that the wood glides smoothly across the work surface, periodically apply a coat of paste wax to the surface of the worktable.
- > Do not attempt to oil the motor bearings or service the motor's internal parts.
- > Switch the product off immediately if you are disturbed while working by other people entering the working area.
- > Do not overwork yourself. Take regular breaks to ensure you can concentrate on the work and have full control over the product.

## After use

- > Switch the product off, disconnect it from the power supply and let it fully cool down before storing.
- > Store the product and its accessories in a dry, frost-free place.
- > Always store the product in a place that is inaccessible to children.

## Lubrication

Lubricate the arm bearings (one on each side of the saw) after every 50 hours of use.

- > Turn the saw on its side and remove the rubber bearing cover.
- > Squirt a generous amount of SAE 20 oil (lightweight motor oil) around the shaft and bearing.
- > Let the oil soak in overnight.
- > Repeat the above procedure for the opposite side of the saw.

## Brushes replacement

Check the condition of the carbon brushes after 50 hours of use. If the brushes are worn to 1/16" (2mm) in length, replace them.

- > Loosen and remove the two brush caps (47) using a flat-blade screwdriver.
- > Pull out each brush (48). Inspect the brush and replace if necessary. Replace both brushes even if only one is damaged.



**NOTE:** After inspecting the brushes, be sure to install the brushes into the same position that they were removed from if you are not installing new ones.

- > Position the brushes into the motor. Tighten the brush caps (47) snugly. Do not overtighten.
- > Run the saw for approximately 5 to 10 minutes to allow the brushes to "seat" themselves. If the brushes are not seated correctly, the electric brake may not function correctly and could damage the motor. While the brushes are seating, some sparking may be noticed in the motor. This is normal for new brushes.

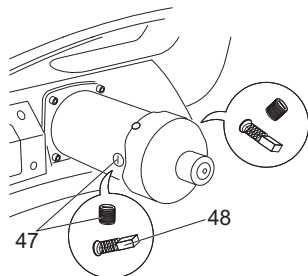

Fig. 22

## Power cord

- > If the power cord is damaged, it must be replaced by the manufacturer, its service agent or similarly qualified person in order to avoid a safety hazard.

## Plug replacement

If you need to replace the fitted plug then follow the instructions below.

### Important

The wires in the mains lead are coloured in accordance with the following code:

**Green & yellow - Earth**

**Blue - Neutral**

**Brown - Live**

As the colours of the wires in the mains lead of this appliance may not correspond with the coloured markings identifying the terminals in your plug, proceed as follows. The wire which is coloured **green & yellow** must be connected to the terminal which is marked with **E** or  $\perp$ .

The wire which is coloured **blue** must be connected to the terminal which is marked with **N**. The wire, which is coloured brown, must be connected to the terminal, which is marked with the letter **L**.

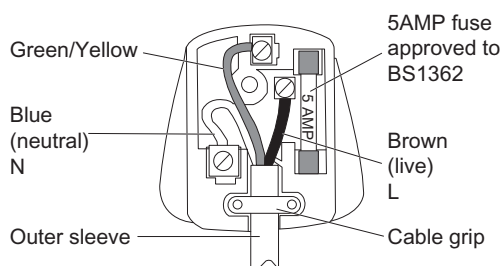

Fig. 23



**Warning:** Never connect live or neutral wires to the earth terminal of the plug. Only fit an approved 5 Amp BS1363/A plug and the correct rated fuse.



**NOTE:** If a moulded plug is fitted and has to be removed take great care in disposing of the plug and severed cable, it must be destroyed to prevent engaging into a socket. If the supply cord is damaged it must be replaced by a service agent or a similarly qualified person in order to avoid hazard.

## Repair

---

- > This product does not contain any parts that can be repaired by the consumer. Contact a qualified specialist to have it checked and repaired.

## Storage

---

- > Clean the product as described previous.
- > Store the product and its accessories in a dry, frost-free place.
- > Always store the product in place that is inaccessible to children. The ideal storage temperature is between 10 and 30°C.
- > We recommend using the original package for storage or covering the product with a suitable cloth to protect it against dust.

## Transportation

---

- > Switch the product off and disconnect it from power supply before transporting it anywhere.
- > Protect the product from any heavy impact or strong vibrations which may occur during transportation in vehicles.
- > Secure the product to prevent it from slipping or failing over.

## Trouble shooting

Suspected malfunctions are often due to causes that the users can fix themselves. Therefore check the product using this section. In most cases the problem can be solved quickly.



**WARNING!** Only perform the steps described within these instructions! All further inspection, maintenance and repair work must be performed by an authorised service centre or a similarly qualified specialist if you cannot solve the problem yourself!



**Caution:** Troubleshooting could lead to an increased risk to the operator due to the fact that safety guards / covers may have to be removed. It is therefore particularly important that all the measures necessary for safe working are taken.

Problem	Possible cause	Solution
1. Breaking Blades	1.1 Incorrect tension 1.2 Overworked (worn out) blade 1.3 Wrong blade being used  1.4 Twisting blade in wood	1.1 Adjust blade tension 1.2 Reduce feed rate or replace blade 1.3 Use narrow blades for thin wood, wider blades for thicker wood 1.4 Avoid side pressure on blade
2. Motor Will Not Run	2.1 Defective cord, plug or outlet 2.2 Defective motor	2.1 Unplug saw, replace defective parts 2.2 Repairs MUST be made by a qualified technician. Call Service dept. for advice

<b>Problem</b>	<b>Possible cause</b>	<b>Solution</b>
3. Excessive Vibration (Some vibration is inevitable when the saw and motor are running)	3.1 Improper mounting of saw 3.2 Unsuitable mounting surface 3.3 Loose table 3.4 Motor mount is loose	3.1 See proper mounting instruction 3.2 Replace plywood workbench surface with solid lumber surface 3.3 Tighten table adjuster knob 3.4 Tighten motor mount screws
4. Blade runout	4.1 Insufficient blade tension 4.2 Dull blade causing excessive force to be used at workpiece	4.1 Increase blade tension 4.2 Renew blade and correctly tension



## Recycling and disposal

---



- > Waste electrical products should not be disposed of with household waste. Please recycle where facilities exist. Check with your Local Authority or local store for recycling advice.

# TITAN®

## Declaration of Conformity

We, Importer  
**Titan Power Tools (UK) Ltd**  
Trade House, Mead Avenue, BA22 8RT

Declare that the product:  
**Designation: 240W scroll saw**  
**Model: TTB545SSW**

Complies with the following Directives:  
**2004/108/EC** Electromagnetic Compatibility Directive  
**2006/42/EC** Machinery Directive  
**2006/95/EC** Low Voltage Directive  
**2011/65/EU** Restrictions of the Use of Certain Hazardous Substances in Electrical and Electronic Equipment  
**2002/96/EC and 2003/108/EC** Waste Electrical and Electronic Equipment (WEEE)

Standards and technical specifications referred to:

**EN 61029-1:2010**  
**EN 55014-1:2006**  
**EN 55014-2:1997+A1:2001+A2:2008**  
**EN 61000-3-2:2006**  
**EN 61000-3-3:2008**

Authorised Signatory and technical file holder  
Date : 20/07/2013

Signature: P.C. Harries

Name / title: Peter Harries / Quality Manager  
Titan Power Tools (UK) Ltd. Trade House, Mead Avenue, BA22 8RT



**240W SCROLL SAW**

**TTB545SSW**



Titan Power Tools (UK) Ltd  
Trade House, Mead Avenue,  
BA22 8RT

---