

ENERGER

150W BENCH GRINDER

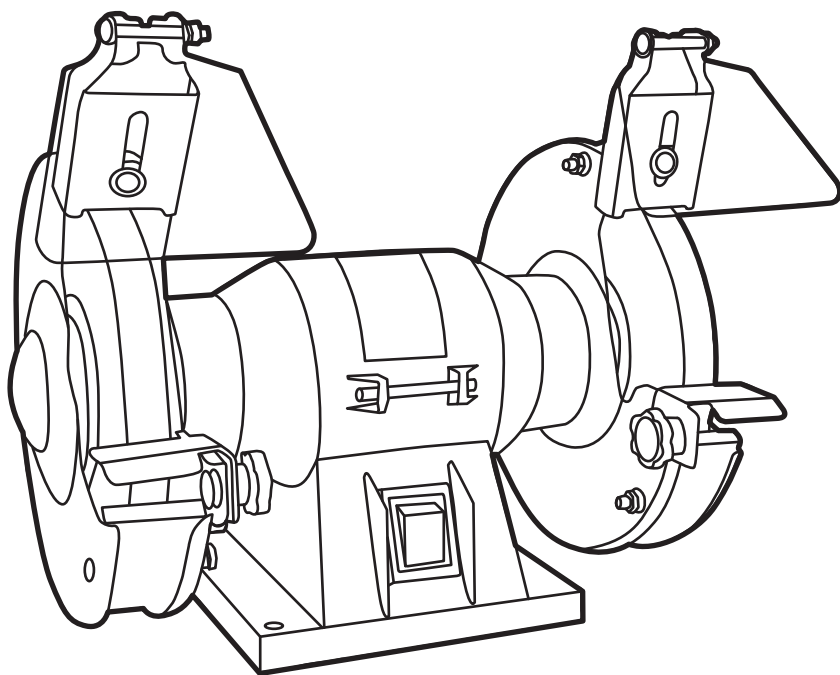

ENB519GRB
Barcode:5052931248209



WARNING! Read the instructions before using the product!



Thank you for choosing a product **ENERGER** it will give you full satisfaction in your craft in the work.

The band saw is a product easy to use, it comes with accessories. For best use, you must read this notice. It will provide key information on the functions of the device and the rules to follow for maintenance.

Please keep this manual for future reference later.

Let's get started...

These instructions are for your safety. Please read through them thoroughly before use and retain them for future reference.



Getting started...

Your product
Technical and legal information
Before you start

03

04

05

11



In more detail...

Operation
Care and maintenance
Trouble **shooting**
Recycling and disposal
Guarantee
EC declaration of conformity

15

16

18

22

22

23

24

Your product

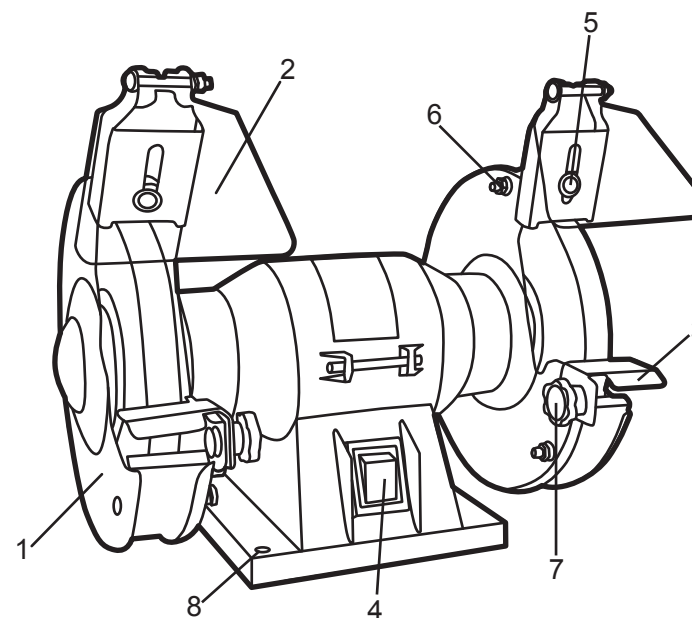

1. Wheel guard
2. Eye shield with mounting bracket
3. Adjustable tool rest
4. On/Off switch
5. Eye shield securing nut, screw & washer
6. Wheel guard securing nut, screw & washer
7. Adjustable tool rest securing bolt & knob
8. Mounting holes

Technical specifications

>Voltage	:230V~50Hz
>Rated input	:150 W
>Duty type	:S2:30min
>No load speed	:2950min -1
>Grinding wheel size	:ø150mm x 16 x 12.7mm
>Coarse wheel grit	:#36
>Medium wheel grit	:#60
>Weight	:5.5kg

Noise data

>Sound power level (L _{WA} *)	:62.6dB(A)
>Uncertainty KpA	:3dB
>Noise pressure level (L _{PA} *)	:75.6dB(A)
>Uncertainty KwA	:3dB
Vibration level	:2.5 m/s ²
Uncertainty K	:1.5m/s ²

The declared vibration total value has been measured in accordance with a standard test method and may be used for comparing one tool with another. The declared vibration total value may also be used in a preliminary assessment of exposure. **WARNING:** The vibration emission during actual use of the power tool can differ from the declared total value depending on the ways in which the tool is used. The need to identify safety measures and to protect the operator are based on an estimation of exposure in the actual conditions of use (taking account of all parts of the operating cycle, such as the times the tool is switched off, when it is running idle, in addition to trigger time).

Load factor:
A load factor of S2 30 min(temporary duty) means that you may operate the motor continuously at its nominal power level (250W) for no longer than the time stipulated on the specifications label (30minutes ON period). If you fail to observe this time limit the motor will overheat. During the OFF period the motor will cool again to its starting temperature.



WARNING : When using electric tools basic safety precautions should always be followed to reduce the risk of fire, electric shock and personal injury including the following.
Read all these instructions before attempting to operate this product and save these instructions.

Symbols



Warning! Denotes risk of personal injury, loss of life, or damage to the tool in case of non-observance



Read the instruction manual



The product complies with the applicable European directives and an evaluation method of conformity for his directives was done



Wear ear protection.



Wear eye protection.



Wear respiratory protection.



Take a power tool in the domestic waste! In accordance with European Directive 2002/96/EC on waste electrical and electronic equipment and its implementation in national law, electric tools collected separately and environmentally friendly recycling are fed. Take advantage of the collection facilities. Ask your local government for the collection systems. If electrical appliances are disposed of, can be poisoned for years while the cause hazardous substances into the groundwater and entering the food chain, or flora and fauna



Safety warnings

 **WARNING:** When using electric tools basic safety precautions should always be followed to reduce the risk of fire, electric shock and personal injury including the following. Read all these instructions before attempting to operate this product and save these instructions.

SAFE OPERATION

- > Keep work area clear
 - Cluttered areas and benches invite injuries.
- > Consider work area environment
 - Do not expose tools to rain.
 - Do not use tools in damp or wet locations.
 - Keep work area well lit.
 - Do not use tools in the presence of flammable liquids or gases.
- > Guard against electric shock
 - Avoid body contact with earthed or grounded surfaces (e.g. pipes, radiators, ranges, refrigerators).
- > Keep other persons away
 - Do not let persons, especially children, not involved in the work touch the tool or the extension cord and keep them away from the work area.
- > Store idle tools
 - When not in use, tools should be stored in a dry locked-up place, out of reach of children.
- > Do not force the tool
 - It will do the job better and safer at the rate for which it was intended.
- > Use the right tool
 - Do not force small tools to do the job of a heavy duty tool.
 - Do not use tools for purposes not intended; for example do not use circular saws to cut tree limbs or logs.
- > Dress properly
 - Do not wear loose clothing or jewellery, they can be caught in moving parts.
 - Non-skid footwear is recommended when working outdoors.
 - Wear protective hair covering to contain long hair.
- > Use protective equipment
 - Use safety glasses.
 - Use face or dust mask if working operations create dust.
- > Connect dust extraction equipment
 - If the tool is provided for the connection of dust extraction and collecting equipment, ensure these are connected and properly used.
- > Do not abuse the cord
 - Never yank the cord to disconnect it from the socket.
 - Keep the cord away from heat, oil and sharp edges.

- > Secure work
 - Where possible use clamps or a vice to hold the work.
 - It is safer than using your hand.
- > Do not overreach
 - Keep proper footing and balance at all times.
- > Maintain tools with care
 - Keep cutting tools sharp and clean for better and safer performance.
 - Follow instruction for lubricating and changing accessories.
 - Inspect tool cords periodically and if damaged have them repaired by an authorized service facility.
 - Inspect extension cords periodically and replace if damaged.
 - Keep handles dry, clean and free from oil and grease.
- > Disconnect tools
 - When not in use, before servicing and when changing accessories such as blades, bits and cutters, disconnect tools from the power supply.
- > Remove adjusting keys and wrenches
 - Form the habit of checking to see that keys and adjusting wrenches are removed from the tool before turning it on.
- > Avoid unintentional starting
 - Ensure switch is in "off" position when plugging in.
- > Use outdoor extension leads
 - When the tool is used outdoors, use only extension cords intended for outdoor use and so marked.
- > Stay alert
 - Watch what you are doing, use common sense and do not operate the tool when you are tired.
- > Check damaged parts
 - Before further use of tool, it should be carefully checked to determine that it will operate properly and perform its intended function.
 - Check for alignment of moving parts, binding of moving parts, breakage of parts, mounting and any other conditions that may affect its operation.
 - A guard or other part that is damaged should be properly repaired or replaced by an authorised service centre unless otherwise indicated in this instruction manual.
 - Have defective switches replaced by an authorised service centre.
 - Do not use the tool if the switch does not turn it on and off.
- > Warning
 - The use of any accessory or attachment other than one recommended in this instruction manual may present a risk of personal injury.
- > Have your tool repaired by a qualified person
 - This electric tool complies with the relevant safety rules. Repairs should only be carried out by qualified persons using original spare parts, otherwise this may result in considerable danger to the user.

- > Secure work
 - Where possible use clamps or a vice to hold the work.
 - It is safer than using your hand.
- > Do not overreach
 - Keep proper footing and balance at all times.
- > Maintain tools with care
 - Keep cutting tools sharp and clean for better and safer performance.
 - Follow instruction for lubricating and changing accessories.
 - Inspect tool cords periodically and if damaged have them repaired by an authorized service facility.
 - Inspect extension cords periodically and replace if damaged.
 - Keep handles dry, clean and free from oil and grease.
- > Disconnect tools
 - When not in use, before servicing and when changing accessories such as blades, bits and cutters, disconnect tools from the power supply.
- > Remove adjusting keys and wrenches
 - Form the habit of checking to see that keys and adjusting wrenches are removed from the tool before turning it on.
- > Avoid unintentional starting
 - Ensure switch is in "off" position when plugging in.
- > Use outdoor extension leads
 - When the tool is used outdoors, use only extension cords intended for outdoor use and so marked.
- > Stay alert
 - Watch what you are doing, use common sense and do not operate the tool when you are tired.
- > Check damaged parts
 - Before further use of tool, it should be carefully checked to determine that it will operate properly and perform its intended function.
 - Check for alignment of moving parts, binding of moving parts, breakage of parts, mounting and any other conditions that may affect its operation.
 - A guard or other part that is damaged should be properly repaired or replaced by an authorised service centre unless otherwise indicated in this instruction manual.
 - Have defective switches replaced by an authorised service centre.
 - Do not use the tool if the switch does not turn it on and off.
- > Warning
 - The use of any accessory or attachment other than one recommended in this instruction manual may present a risk of personal injury.
- > Have your tool repaired by a qualified person
 - This electric tool complies with the relevant safety rules. Repairs should only be carried out by qualified persons using original spare parts, otherwise this may result in considerable danger to the user.

ADDITIONAL SAFETY RULES FOR BENCH GRINDERS

- > Never drape the power cable over the machine bench!
- > Wear protective clothing. Wear full face protection, eye protection or safety goggles, in accordance with the job at hand. Where appropriate, wear a dust mask, ear defenders, protective gloves or special aprons that keep grinding and material particles away from you. Protect your eyes from the foreign bodies that fly off during certain applications.
- Dust or breathing masks must be used to filter particles generated by the application. Hearing loss can be caused by exposure to high intensity noise.
- > Always wear a dust mask and safety goggles. Contact with or breathing in noxious / toxic dust produced by grinding metal that is finished with lead paint can be dangerous for the user and surrounding people.
- > This power tool must not be used for wet grinding. Use for dry grinding only. Coolant can weaken the bonding strength of the wheel and cause it to fail.
- > This bench grinder should only be used when stationary. Secure to a solid, even surface.
- > Do not use any accessories that have not been especially designed and recommended for this power tool by the manufacturer. Simply because an accessory can be connected to your power tool does not guarantee it can be used safely.
- > Only use grinding disks whose diameter, thickness and intended use meet the requirements of this power tool. Incorrectly sized grinding disks may not be sufficiently screened or controllable. Use of unsuitable grinding disks can result in danger to the user or damage to the power tool.
- > Never touch the spinning grinding disks! Make sure the grinding disks have come to a complete standstill after turning off before you touch them.
- > When you have checked the tool attachment and have attached it, make sure you and others nearby keep away from the area of the rotating tool attachment and let the appliance run at the maximum speed for a minute. Most damaged tool attachments will break off in this test period.
- > Make sure bystanders are a safe distance from your work area. Anyone entering the work area must wear personal protective clothing. Pieces may break off the work piece or sparks may fly off and can also cause injuries outside the direct work area.
- > Position the power cable clear of the spinning tool attachment. If you lose control of the appliance, the power cable can be severed or tangled and your hands or arms may get caught in the spinning tool attachment.
- > Do not leave the power tool running when you are not using it. Your clothing can become entangled when it comes into contact with the spinning tool attachment, causing the tool attachment to drill into your body.
- > Clean the power tool's air vents regularly. The motor's fan draws dust into the housing and the heavy build-up of metal dust can result in electrical hazards.
- > Do not use the power tool in the vicinity of flammable materials. Sparks may cause these materials to ignite.
- > Do not use any tool attachments that require liquid coolants. Use of water or other liquid coolants can result in electric shock.

- > Before starting up the bench grinder for the 1st time, check the grinding wheels with a sound test. Faultless grinding wheels will make a clear sound when struck gently with a plastic hammer (or piece of wood). If new grinding discs are attached, check these also beforehand.
- > Always use the protective features and wheel guard fitted to or supplied with this power tool. The wheel guard and protective features should be attached securely to the power tool and set so that the maximum safety level can be achieved. The protective features are there to protect the user from broken pieces and accidental contact with the grinding disks.

Unpack

- > Unpack all parts and lay them on a flat, stable surface.
- > Remove all packing materials and shipping devices if applicable.
- > Make sure the delivery contents are complete and free of any damage. If you find that parts are missing or show damage do not use the product but contact your dealer. Using an incomplete or damaged product represents a hazard to people and property.
- > Ensure that you have all the accessories and tools needed for assembly and operation. This also includes proper personal protective equipment.

You will need

Items not supplied	Items supplied
1. Protective gloves	1. worepiece support
2. Screwdriver with PH2 head	2. spark guard
	3. Mounting nuts, bolts and washers



WARNING! Do not connect to power supply until assembly is complete. Failure to comply could result in accidental starting and possible serious injury.

Install the spark guard

- > To fit the eye shields locate the nut, screw and washers provided through the slot in the eye shield and hole on the grinding wheel guard and finger tighten. Position the eye shield so it does not come in to contact with the grinding wheel. Tighten the nut and screw to secure the eye shield in place.

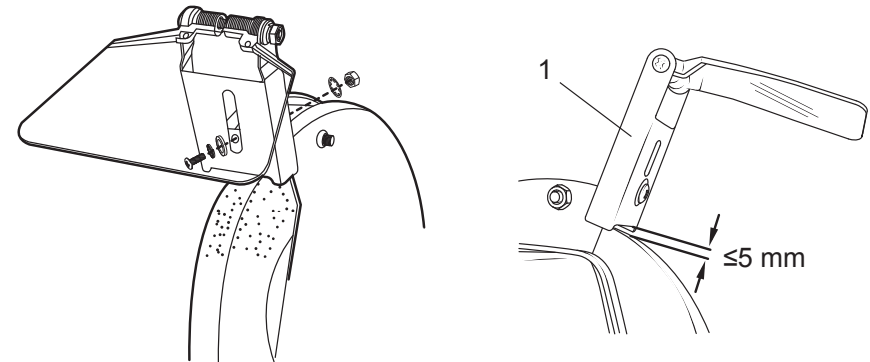

WARNING! The adjustable safety plate (1) of the spark guard must be assembled in such a way that the gap between cutting disc and adjustable safety plate is max. 5 mm

Install the workpiece support

- > The workpiece support (2) must be assembled in such a way that the gap between grinding disc and workpiece support is max. 3mm.

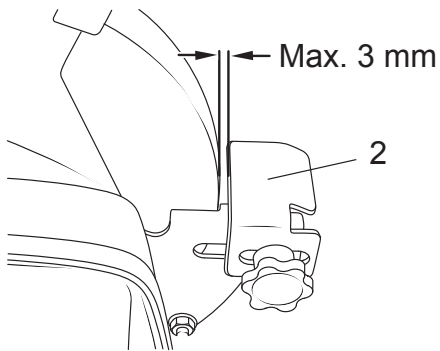

Mounting the bench grinder

- > The machine is to be assembled firmly on a suitable place. Four holes are available to fix on a firm and solid base e.g. on a workbench or machine stand.
- Ensure that the mains connection is located not more than approx. 100-150cm from the place of fixation.
- The machine must be easily accessible from front and left side.

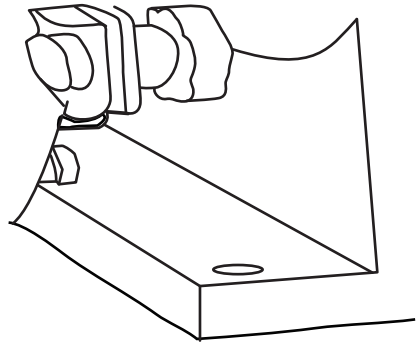

Connection to the power supply

- > Connect the plug with a suitable socket.
- WARNING! Check the voltage! The voltage must comply with the information on the rating label!
- > Your product is now ready to be used.

WARNING! Do not use until the product has been securely installed to a work bench.



In more detail...

Operation	16
Care and maintenance	18
Trouble shooting	22
Recycling and disposal	22
Guarantee	23
EC declaration of conformity	24

Dry grinding

- > Hold the workpiece to be worked on with both the hands and support it on the workpiece support.
- > Press the workpiece with proper pressure against the grinding disc.



NOTE: The machine is designed for rough and fine grinding. The dry grinding disc is thus suitable only for rough grinding (roughing).

SWITCHING ON AND OFF

Before connecting to the power supply rotate the wheel by hand to ensure that it is running free from obstruction. Connect to the mains supply and press the rocker switch to the ON position (I) and allow your grinder to reach the maximum speed before commencing grinding. Hold the workpiece firmly against the work rest and feed it smoothly and evenly to the grinding wheel. Grinding action tends to slow the wheel down, pressure should therefore be occasionally released to allow the wheel to regain the full speed.

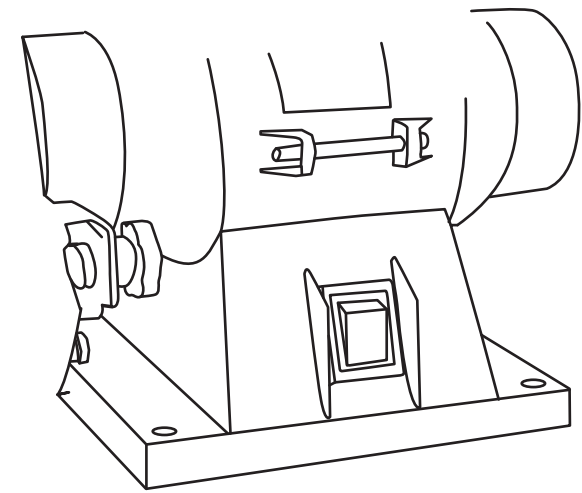

General operation

1. After switching the grinder on, allow it to reach full speed before performing grinding operation.
2. The eye shields are able to be adjusted and should be positioned to allow the operator a clear view of the work through the shields.
3. The appropriate adjustments of the tools rests will provide the correct working angle for efficient grinding. As the diameter of the grinding wheel is subject to wear. It will be necessary to re-adjust the edge of the grinding wheel.

Fix the grinder to horizontal, stable surface before using. Positing the grinder towards the front edge of the bench will facilitate the handing of long tools. If possible, leave space to the left hand side of the machine for easy access to the wet wheel. An alternative method is to secure the grinder to a sheet of plywood which can then be clammed to a bench or table to present the grinder in the most convenient position. Before using the dry wheel ensures that the spark guard (behind the eye shield) is positioned as close to the surface of the wheel as possible and that the eye shield is in a position to prevent sparks flying up. It is a sensible precaution to wear safety spectacles as well when operating a grinding machine. The dry wheel can be used for grinding profiles or virtually any cutting tool; plane irons, chisel, gouges, turning tools, drill bits, etc. The aluminum oxide will cut cleanly and without undue heating of the tip of the tool. However care should be taken not to grind a tool too hard or for too long in case over-heating occurs.

The golden rules of care

1. Keep the product clean. Remove debris from it after each use and before storage.
2. Regular and proper cleaning will help ensure safe use and prolong the life of the product.
3. Inspect the product before each use for worn and damaged parts. Do not operate it if you find broken and worn parts.



WARNING! Always switch the product off, disconnect it from power supply and let the product cool down before performing inspection, maintenance and cleaning work!



WARNING! Only perform repairs and maintenance work according to these instructions! All further works must be performed by a qualified specialist!

General cleaning

1. Clean the product with a dry cloth. Use a brush for areas that are hard to reach.
2. Check for worn or damaged parts. Replace worn parts as necessary or contact an authorised service centre for repair before using the product again.



NOTE: Do not use chemical, alkaline, abrasive or other aggressive detergents or disinfectants to clean this product as they might be harmful to its surfaces.

Grinding wheel replacement

To renew or change the grinding wheels, follow these series of steps:

1. Switch off the unit and disconnected from the mains supply.
2. Remove the fixing screws(1) on the outside cover(2) and then pull out the outside cover(2).
3. Remove the nut (3) from the spindle (5) using spanner supplied. The nut on the right spindle has a right thread; the nut on the left spindle has a left thread.
4. Take out the outer flange (4) from the spindle (5).
5. Place the new wheel onto the spindle. once secured rotate the grinding wheel by hand to confirm that the wheel moves freely and doesn't contact any surfaces.
6. Reassemble the flange, nut, and outside cover.
7. Switch on the machine and let the wheel run with no load for one minute to check for cracks.

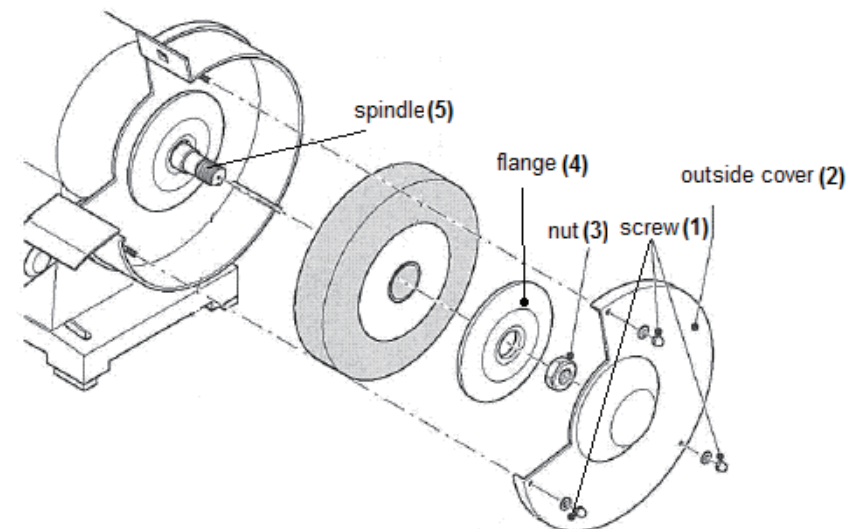

GRINDING WHEEL INFORMATION

The following information is a guide only on the different types of grinding wheels and their uses.

TYPES OF ABRASIVE GRAIN

Grinding wheels are made of four main types of abrasive grain: aluminum oxide, silicon carbide, CBN (cubic boron nitride) and diamond. In the home workshop you will probably only use wheels of aluminum oxide or silicon carbide. Both types are available from your tool stockiest. Grain size is separated into four main categories: course, medium, fine and very fine. Table 1 shows the breakdown of grain size in each category. For most work a medium or fine wheel is recommended.

TABLE 1

The four main categories of abrasive grains

Coarse	Medium	Fine	Very Fine
12	46	70	150
14	60	80	180
16		90	220
20		100	240
24		120	
30			
36			

TYPES OF BOND

There are five main kinds of bonding agents namely, ceramic (vitrified), phonetic resin, rubber, shellac and metal. The abrasive can be bonded with its particles close together or with spaces between each grain particle. Bond material creates a link between each grain. The spaces between the grains will determine how dense the wheel is, large spaces will give an open wheel and smaller spaces will give a close or dense wheel.

The structure is measured on a scale of 0-14 with 0 being very close and 14 being very open with wide spacing between the grains.

WHEEL HARDNESS OR GRADE

Grade or hardness is the strength of bonding between the abrasive grains. Wheel hardness is graded alphabetically, in increasing order of hardness; letters A through D represent very soft wheels, and letters V through Z represent very hard ones. Letter K in the illustration below represents a soft to medium wheel.

9A – 46 – K5 – V 22

9A	46	K	5	V	22
Kind of Abrasive	Grain Size	Grade	Destiny	Bond Type	Manufacturers Symbol

The number shown in the above illustration is an example of a grinding wheel description. 9A means that the abrasive is aluminum oxide, 46 means that the grain size is medium, K means that the wheel is soft, 5 means that the wheel is dense, V stands for vitrified bonding and 22 is the manufacturer's symbol. Wheels supplied with bench grinders are generally "N" on the hardness scale, which is considered hard. Do not try to sharpen carbide tools, knives, scissors or high-speed tools (router bits, wood turning tools) with this hard wheel. A standard wheel will not cut carbide. If you try, you will only create heat and glaze over the wheel. Hard wheels will burn router bits and other high-speed tools. Overheating the tools will destroy their hardness and render them useless. Soft wheels give themselves up while grinding. When grinding, only a small amount of material is removed, and the wheel releases grains a little at a time, presenting new cutting edges. This releasing activity helps to keep the tool from heating up and gives a finer grinding result.

Table 2 shows wheel hardness and uses.

TABLE 2

Wheel Hardness (Grade)	Uses for designated hardness	Description of hardness
A B C D	Not used very often	Very soft
E F G H I J K L	Use these soft wheels to sharpen high -speed -steel tools, such as router bits, drills, and tool bits.	Soft to medium
M N O P Q R S T	Use these wheels for rough grinding on soft materials.	Medium to hard
U	This hard grade is used for dressing sticks to dress grinding wheels.	Hard
V W X Y Z	Not used very often	Very hard

The following table 3 should help you to select the correct grinding wheel for the job. New bench grinders are supplied with grey wheels. All other types of grinding wheel are available from your tool stockiest.

TABLE 3

Type of tool	Tool material	Recommended wheel type
Drill bits Spade boring bits Masonry drill bits	High-speed steel High-speed steel Cutting edge is carbide	Aluminum oxide (grey) Aluminum oxide (grey) Silicon carbide (green)
Lathe tool bits	High-speed steel	Soft aluminum oxide (Pink or white)
Chisels	High-speed steel	Soft aluminum oxide (Pink or white)
Router bits High-speed steel carbide tipped	High-speed steel Cutting edge is carbide	Soft aluminum oxide (Pink or white) Silicon carbide (green)
Rotary lawnmower blade	Non heat-treated steel	Aluminum oxide (grey)
Scissors & snips	Hard steel (but not file hard)	Aluminum oxide (Pink or white)

In more detail...

In more detail...

Power cord

If the power cord is damaged, it must be replaced by the manufacturer, its service agent or similarly qualified persons in order to avoid a safety hazard.

UK plug

- > As the colours of the wire in the mains lead of this appliance may not correspond with the coloured markings identifying the terminals in your plug, proceed as follows. The wire, which is coloured blue, must be connected to the terminal, which is marked with N or coloured black. The wire, which is coloured brown, must be connected to the terminal, which is marked L or coloured red.
- > No connection is to be made to the Earth terminal of the plug.
- > Only fit an approved 13 Amp BS1363/a plug and the correct rated fuse.
- > If in doubt, consult a qualified electrician.
- > NOTE: If a moulded plug is fitted and has to be removed take great care in disposing of the plug and severed cable, it must be destroyed to prevent engaging into a socket.

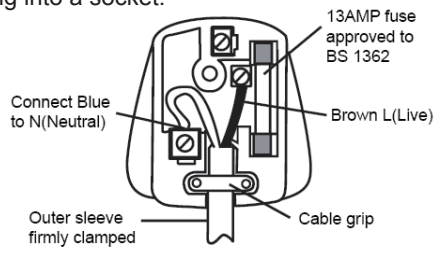

Repair

1. This product does not contain any parts that can be repaired by the consumer. Contact a qualified specialist to have it checked and repaired.

Storage

1. Clean the product as described above.
2. Store the product and its accessories in a dry, frost-free place.
3. Always store the product in a place that is inaccessible to children. The ideal storage temperature is between 10 and 30°C.
4. We recommend using the original package for storage or covering the product with a suitable cloth to protect it against dust.

Transportation

1. Switch the product off and disconnect it from power supply before transporting it anywhere.
2. Attach transportation guards, if applicable.
3. Always carry the product by its handle.
4. Protect the product from any heavy impact or strong vibrations which may occur during transportation in vehicles.
5. Secure the product to prevent it from slipping or falling over.

Trouble shooting

Suspected malfunctions are often due to causes that the user can fix themselves. Therefore check the product using this section. In most cases the problem can be solved quickly.

Problem	Possible cause	Solution
1. Product does not start	1.1 Not connected to power supply 1.2 Power cord or plug is defective 1.3 Other electrical defect to the product	1.1. Connect to power supply 1.2. Check by a specialist electrician. 1.3. Check by a specialist electrician
2. Product does not reach full power	2.1 Extension cord not suitable for operation with this product 2.2 Power source (e.g. generator) has too low voltage 2.3 Air vents are blocked	2.1. Use a proper extension cord 2.2. Connect to another power source 2.3. Clean the air vents
3. Unsatisfactory result	3.1 Accessory not suitable for work piece material	3.1. Use proper accessory



WARNING! Only perform the steps described within these instructions! All further inspection, maintenance and repair work must be performed by an authorised service centre or a similarly qualified specialist if you cannot solve the problem yourself!

Recycling and disposal



Waste electrical products should not be disposed of with household waste. Please recycle where facilities exist. Check with your Local Authority or local store for recycling advice.

Guarantee

This ENERGER product carries a guarantee of 12months.

If your product develops a fault within this period, you should, in the first instance contact the retailer where the item was purchased.

This guarantee specifically exclude losses caused due to:

- > Fair wear and tear
- > Misuse or abuse
- > Lack of routine maintenance
- > Failure of consumable items
- > Accidental damage
- > Cosmetic damage
- > Failure to follow manufacturer's guidelines
- > Loss of use of the goods This guarantee does not affect yours tatutory rights.

This guarantee is only valid in the UK. For any enquiries relating to the guarantee please refer to your retailer.



Declaration of conformity

We, Importer
Powersmith Ltd., BA22 8RT

Declare that the product:

Designation: 150w Bench grinder

Model: ENB519GRB

Complies with the following Directives

2004/108/EC Electromagnetic Compantibility Directive

2006/42/EC Machinery Directive

2006/95/EC Low voltage Directive

2011/65/EU Restrictions of the Use of Certain Hazardous Substances
in Electrical and Electronic Equipment

2002/96/EC and 2003/108/EC Waste Electrical and Electronic Equipment(WEEE)

Standards and technical specifications referred to:

EN61029-1/A11:2010

EN61029-2-4:2011

EN55014-1/A2:2011

EN55014-2/A2:2008

EN61000-3-2/A2:2009

EN61000-3-3:2008

Authorised Signatory and technical file holder

Date : 10/09/2013

Signature: P.C. Harries

Name / title: Peter Harries / Quality Manager
Powersmith (UK) LTD. Trade House Mead Avenue, BA22 8RT



2013



Powersmith (UK) LTD.
Trade House Mead Avenue, BA22 8RT
