

# TITAN<sup>®</sup>

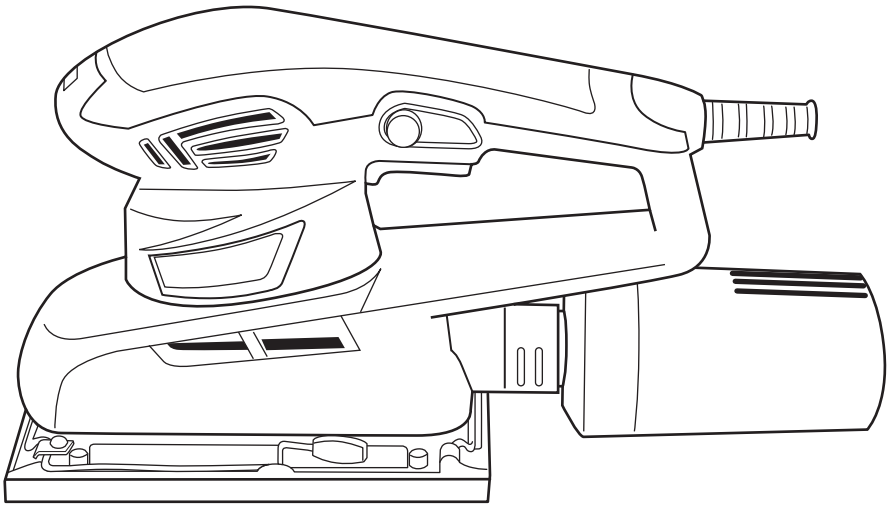

**24** **month**  
Manufacturer's  
Warranty

## **SAFETY AND OPERATING MANUAL**

Original instructions

**FINISH SANDER 220W**

**TTB288SDR**

# TITAN®

**Congratulations on your purchase of a TITAN power tool from Titan Power Tools (UK) Ltd. We want you to continue getting the best performance from it so this handbook includes information on safety, handling and care. Please retain this handbook in case you need to refer to any of the information in the future.**

**Your TITAN power tool comes with a 24-month guarantee, so should it develop a fault within this period contact your retailer.**

## **GUARANTEE**

This **TITAN** product carries a guarantee of 24 months. If your product develops a fault within this period, you should, in the first instance contact the retailer where the item was purchased.

This guarantee specifically excludes losses caused due to:

- Fair wear and tear
- Misuse or abuse
- Lack of routine maintenance
- Failure of consumable items (such as batteries)
- Accidental damage
- Cosmetic damage
- Failure to follow manufacturer's guidelines
- Loss of use of the goods

This guarantee does not affect your statutory rights. This guarantee is only valid in the UK.

For any enquiries relating to the guarantee please refer to your retailer.

# GENERAL SAFETY INSTRUCTIONS



**WARNING! Read all safety warnings designated by the symbol  and all instructions.**



**WARNING! Read all safety warnings and all instructions.** Failure to follow the warnings and instructions may result in electric shock, fire and/or serious injury. **Save all warnings and instructions for future reference.**

The term "power tool" in the warnings refers to your mains-operated (corded) power tool or battery-operated (cordless) power tool.

## 1. Work area safety

**a. Keep work area clean and well lit.** Cluttered or dark areas invite accidents.

**b. Do not operate power tools in explosive atmospheres, such as in the presence of flammable liquids, gases or dust.** Power tools create sparks which may ignite the dust or fumes.

**c. Keep children and bystanders away while operating a power tool.**

Distractions can cause you to lose control.

## 2. Electrical safety

**a. Power tool plugs must match the outlet. Never modify the plug in any way. Do not use any adapter plugs with earthed (grounded) power tools.**

Unmodified plugs and matching outlets will reduce risk of electric shock.

**b. Avoid body contact with earthed or grounded surfaces, such as pipes, radiators, ranges and refrigerators.** There is an increased risk of electric shock if your body is earthed or grounded.

**c. Do not expose power tools to rain or wet conditions.** Water entering a power tool will increase the risk of electric shock.

**d. Do not abuse the cord. Never use the cord for carrying, pulling or unplugging the power tool. Keep cord away from heat, oil, sharp edges or moving parts.** Damaged or entangled cords increase the risk of electric shock.

**e. When operating a power tool outdoors, use an extension cord suitable for outdoor use.** Use of a cord suitable for outdoor use reduces the risk of electric shock.

**f. If operating a power tool in a damp location is unavoidable, use a residual current device (RCD) protected supply.** Use of an RCD reduces the risk of electric shock.

## 3. Personal safety

**a. Stay alert, watch what you are doing and use common sense when operating a power tool. Do not use a power tool while you are tired or under the influence of drugs, alcohol or medication.** A moment of inattention while operating power tools may result in serious personal injury.

**b. Use personal protective equipment. Always wear eye protection.** Protective equipment such as dust mask, non-skid safety shoes, hard hat, or hearing protection used for appropriate conditions will reduce personal injuries.

**c. Prevent unintentional starting. Ensure the switch is in the off-position before connecting to power source and/or battery pack, picking up or carrying the tool.** Carrying power tools with your finger on the switch or energising power tools that have the switch on invites accidents.

**d. Remove any adjusting key or wrench before turning the power tool on.** A wrench or a key left attached to a rotating part of the power tool may result in personal injury.

**e. Do not overreach. Keep proper footing and balance at all times.** This enables better control of the power tool in unexpected situations.

**f. Dress properly. Do not wear loose clothing or jewellery. Keep your hair, clothing and gloves away from moving parts.** Loose clothes, jewellery or long hair can be caught in moving parts.

**g. If devices are provided for the connection of dust extraction and collection facilities, ensure these are connected and properly used.** Use of dust collection can reduce dust-related hazards.

#### **4. Power tool use and care**

**a. Do not force the power tool. Use the correct power tool for your application.** The correct power tool will do the job better and safer at the rate for which it was designed.

**b. Do not use the power tool if the switch does not turn it on and off.** Any power tool that cannot be controlled with the switch is dangerous and must be repaired.

**c. Disconnect the plug from the power source and/or the battery pack from the power tool before making any adjustments, changing accessories, or storing power tools.** Such preventive safety measures reduce the risk of starting the power tool accidentally.

**d. Store idle power tools out of the reach of children and do not allow persons unfamiliar with the power tool or these instructions to operate the power tool.** Power tools are dangerous in the hands of untrained users.

**e. Maintain power tools. Check for misalignment or binding of moving parts, breakage of parts and any other condition that may affect the power tool's operation. If damaged, have the power tool repaired before use.** Many accidents are caused by poorly maintained power tools.

**f. Keep cutting tools sharp and clean.** Properly maintained cutting tools with sharp cutting edges are less likely to bind and are easier to control.

**g. Use the power tool, accessories and tool bits etc. in accordance with these instructions, taking into account the working conditions and the work to be performed.** Use of the power tool for operations different from those intended could result in a hazardous situation.

#### **5. Service**

**a. Have your power tool serviced by a qualified repair person using only identical replacement parts.** This will ensure that the safety of the power tool is maintained.

## **ADDITIONAL SAFETY INSTRUCTIONS FOR YOUR SANDER**



**WARNING.** Contact with or inhalation of harmful / toxic dusts arising from sanding lead-based painted surfaces, woods and metals can endanger the health of operator and bystanders.

Take special care to guard against these dusts, including the following:

- All persons entering the work area must wear an approved mask specially designed for protection against harmful / toxic dusts, in addition to using the dust extraction facility, and keeping work area well ventilated.
- Children and pregnant women must not enter the work area.
- Do not eat, drink or smoke in the work area.

Any pre1960 building may have paint containing lead on wood or metal surfaces. If you suspect the workpiece contains lead seek professional advice.

- Some wood and wood type products especially MDF (Medium Density Fibreboard) can produce dust that can be hazardous to your health. We recommend the use of an approved face mask with replaceable filters when using this machine in addition to using the dust extraction facility.
- Hold the machine correctly using two hands and adopt a stable stance, make sure that the mains cable is prevented from coming into contact with the machine or getting caught up on other objects preventing completion of the sanding pass.
- Do not use the dust collection box when sanding metal. The hot metal particles could cause residual wood dust or the internal filter to catch fire.

- 1.** Never use this sander for wet sanding or liquid polishing. Failure to follow this rule may result in risk of electrical shock.
- 2.** Always wear eye protectors when using this sander.
- 3.** Always wear a dust mask when using this sander.
- 4.** Always inspect and remove all nails and screws etc from timber before sanding.
- 5.** Always check walls and ceiling to avoid hidden power cables and pipes. A metal detector can be obtained from any good DIY store for this purpose.
- 6.** If possible, ensure the workpiece is firmly clamped to prevent movement.
- 7.** Your sander is a hand held tool, do not clamp your finishing sander.
- 8.** Never stop the sander by applying a force to the base plate.
- 9.** Only use sanding paper in good condition. Do not use torn or worn sanding paper.
- 10.** Do not sand magnesium material due to the risk of fire.
- 11.** Do not sand material including asbestos due to a health rise.
- 12.** Do not sand lead based paint due to the rise of lead poisoning.
- 13.** Do not eat or drink in the working area of the sander.
- 14.** Do not allow people to enter the working area without wearing a dust mask.
- 15.** Where possible, seal off the working area to contain the dust for later removal.



**WARNING!** Some dust particles created by power sanding, sawing, grinding, drilling and other construction jobs contain chemicals known to cause cancer, birth defects or other reproductive harm. Some examples of these chemicals are:  
Lead from lead-based paints.

Crystalline silica from bricks and cement and other masonry products.

Arsenic and chromium from chemically treated timber.

Your risk from these exposures varies, depending upon how often you do this type of work. To reduce your exposure to these chemicals:

Work in a well ventilated area.

Work with approved safety equipment, such as those dust masks that specially designed to filter out microscopic particles and use the dust extraction facility at all time.

- Wear ear protectors when sanding. Exposure to noise can cause hearing loss.

## VIBRATION

The European Physical Agents (Vibration) Directive has been brought in to help reduce hand arm vibration syndrome injuries to power tool users. The directive requires power tool manufacturers and suppliers to provide indicative vibration test results to enable users to make informed decisions as to the period of time a power tool can be used safely on a daily basis and the choice of tool.

Further Advice can be found at [www.hse.gov.uk](http://www.hse.gov.uk)

Vibration total values (triax vector sum) determined according to EN 60745:	
Sanding	Vibration emission value $a_h = 5.439\text{m/s}^2$
	Uncertainty $K = 1.5\text{m/s}^2$

The declared vibration emission value should be used as a minimum level and should be used with the current guidance on vibration.

Calculating the actual period of the actual period off use can be difficult and the HSE website has further information.

The declared vibration emission been measured in accordance with a standardised test stated above and may be used to compare one tool with another.

The declared vibration emission value may also be used in a preliminary assessment of exposure.



**Warning:** The vibration emission value during actual use of the power tool can differ from the declared value depending on the ways in which the tool is used dependant on the following examples and other variations on how the tool is used:

How the tool is used and the materials being sanded.

The tool being in good condition and well maintained

The use the correct accessory for the tool and ensuring it is sharp and in good condition.

The tightness of the grip on the handles.

And the tool is being used as intended by its design and these instructions.

**This tool may cause hand-arm vibration syndrome if its use is not adequately managed**



**Warning:** identify safety measures to protect the operator that are based on an estimation of exposure in the actual conditions of use (taking account of all parts of the operating cycle such as the times when the tool is switched off and when it is running idle in addition to the trigger time). Note The use of other tools will reduce the users' total working period on this tool.

Helping to minimise your vibration exposure risk.

Maintain this tool in accordance with these instructions and keep well lubricated (where appropriate)

Avoid using tools in temperatures of 10°C or less

Plan your work schedule to spread any high vibration tool use across a number of days.

Health Surveillance

All employees should be part of an employer's health surveillance scheme to help identify any vibration related diseases at an early stage, prevent disease progression and help employees stay in work.

**Double insulation:** 

The tool is double insulated. This means that all the external metal parts are electrically insulated from the mains power supply. This is done by placing insulation barriers between the electrical and mechanical components making it unnecessary for the tool to be earthed.

**Important note:**

Be sure the supply is the same as the voltage given on the rating plate. The tool is fitted with a two-core cable and plug.

Remove the mains plug from socket before carrying out any adjustment or servicing.

## SYMBOLS



To reduce the risk of injury, user must read instruction manual



Warning



Waste electrical products should not be disposed of with household waste. Please recycle where facilities exist. Check with your Local Authority or retailer for recycling advice.



Wear ear protection



Wear eye protection



Wear dust mask



Double insulation



Conformity to CE directive



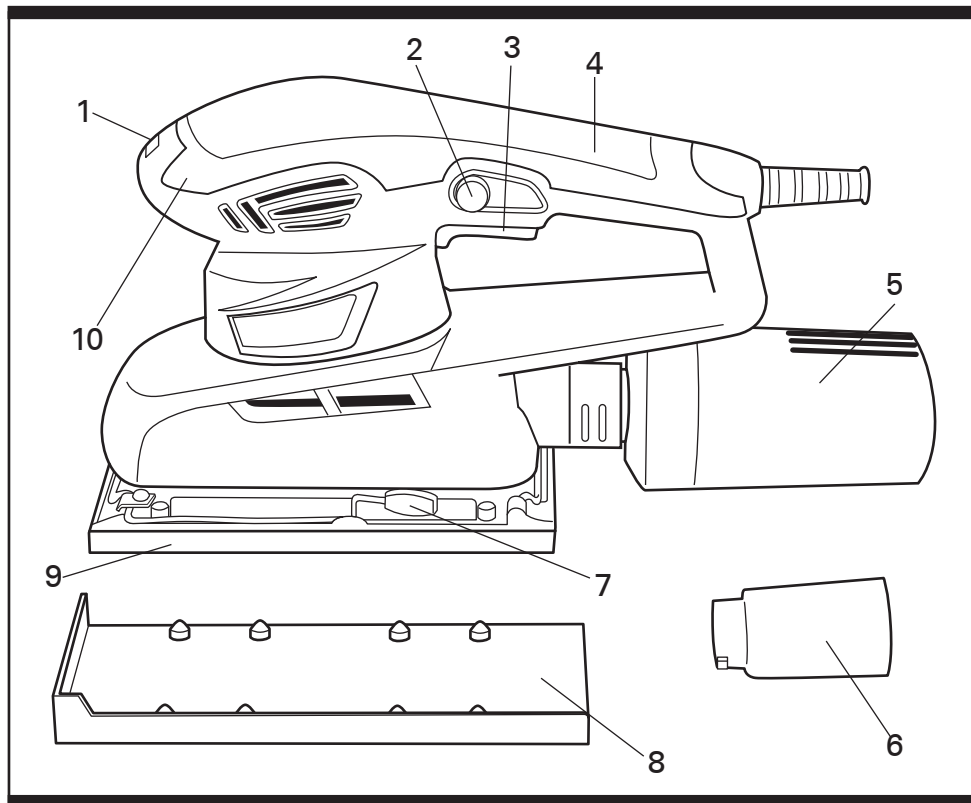

**1 SPEED SWITCH**

**2 LOCK-ON BUTTON**

**3 TRIGGER SWITCH**

**4 MAIN GRIP**

**5 DUST COLLECTION BOX**

**6 DUST EXTRACTION ADAPTER**

**7 SANDING PAPER RETAINING CLIP**

**8 HOLE PUNCH**

**9 SANDING BASE PLATE**

**10 FRONT GRIP**

**FINISH SANDER 220W**

**TTB288SDR**

## TECHNICAL DATA

Voltage:	230-240V~ 50Hz
Input power:	220W
No load speed:	0-11000/min
Base size:	90x187mm
Sanding paper fixing:	hook&loop, or clamp
Protection class:	II
Machine weight:	2kg

## NOISE DATA

A weighted sound pressure	69.0dB(A) / KpA: 3dB(A)
A weighted sound power	80.0dB(A) / KwA: 3dB(A)
Wear ear protection when sound pressure is over	80dB

## ACCESSORIES

<b>Dust collection box</b>	<b>1pc</b>
<b>Dust extraction adapter</b>	<b>1pc</b>
<b>Sanding paper</b>	<b>3pcs</b>
<b>Hole punch</b>	<b>1pc</b>

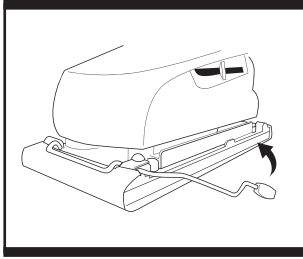

**Fig. 1**

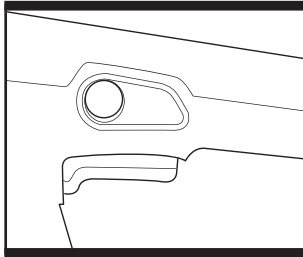

**Fig. 2**

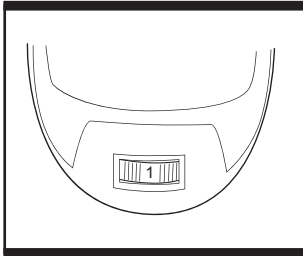

**Fig. 3**

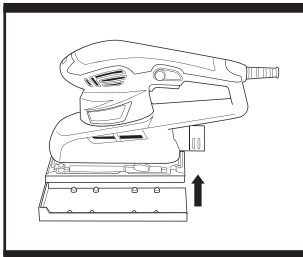

**Fig. 4**

## OPERATIONS INSTRUCTIONS



**Note:** Before using the tool, read the instruction book carefully.

### INTENDED USE

This sander shall be used for sanding metal, wood, plastic or similar materials. Other uses for the tool will lead to the damage of the tool and a series of dangers to the operator. This tool is intended for DIY home use , or occasional professional use.

#### 1. CHANGING SANDPAPER (Fig. 1)

Use a 1/3 standard sheet of sandpaper.

To remove used sandpaper sheet, pull the levers on each side of the sander then unwrap the used paper from the retaining clips and remove it. You can now install a new one (Use a 1/3 standard sheet of sandpaper). Put one end under the spring clip and reset clip. Press the sandpaper around the base plate shape as tight as possible. Wrap the sandpaper around the bottom of the sander and insert another end into spring clip and reset clip. Check to make sure that the sandpaper is square to the base plate and remove or refit again if not correct.

ALWAYS make sure the sandpaper is even with the edges and that the dust collection holes in the base and sandpaper is aligned and that the sandpaper is tight on the base.

You can also install hook-and-loop sanding pads under the base of your sander.

#### 2. SWITCHING ON AND OFF (Fig. 2)

Start the tool by squeezing the trigger switch. Release the trigger switch to stop the tool. If you press the lock on button, the tool will work continuously. If working for long periods of time the lock on button can be used to keep the sander switched on. To release the lock on button, press and release the trigger switch. Always lift the sander from the work before switching on or off or the finish of the workpiece may be damaged.

#### 3.VARIABLE SPEED CONTROL SWITCH

(Fig. 3)

Adjust the dial to increase or decrease the speed according to the working materials. The speed increases as the numbers on the dial increase. Avoid prolonged use at very low speed as this may damage your sander's motor.

#### 4. PUNCH THE HOLE (Fig. 4)

If using sanding paper without dust holes, use the paper punch to perforate the holes to ensure correct dust extraction. After fitting the sanding paper, put the hole punch on the sanding paper align the sanding base edges. Then press the hole punch toward the sander which will punch the hole in the sandpaper.

#### 5. ATTACHING SANDER TO VACUUM (Fig. 5)

(Fig. 5)

Your sander is equipped with a dust extraction adaptor. Insert the adaptor into the grooves of the rear dust outlet of the sander then turn it clockwise to lock it.

When it's done you can connect the hose of a vacuum cleaner to the adaptor.

First please turn on the vacuum cleaner, then turn on the sander. If you stop sanding, first turn off the sander, then turn off your vacuum cleaner.

#### 6. DUST COLLECTION BOX (Fig. 6)

Your sander is equipped with a dust collection box. To attach, insert the dust collection box into the back of the sander in correct position. Then turn the box clockwise. Pull the box and make sure the box is tightened securely on the dust extraction nozzle.



**WARNING.** Do not use the dust collection box when sanding metal. The hot metal particles could cause residual wood dust or the internal filter to catch fire.

#### 7. SANDING

For a finer finish you start with a low number grade of sandpaper or and then use higher number (finer) paper until the the surface finish is acceptable.

Always keep moving the sander in slow directions for the best results , if the snder is held in a stationary position then it could remove excessive material from this position.

#### WORKING HINTS FOR YOUR SANDER

1. Your sander is useful for working on wood, metal, painted surfaces. It will smooth surfaces prior to painting, even where fillers have been used and left proud.
2. Your sander is best suited to flat areas such as doors but can also be used on skirting boards, windows, etc, provided they are accessible.

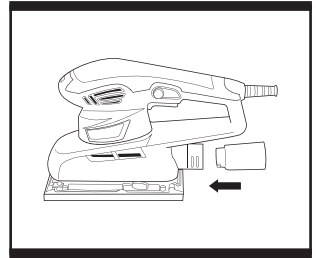

Fig. 5

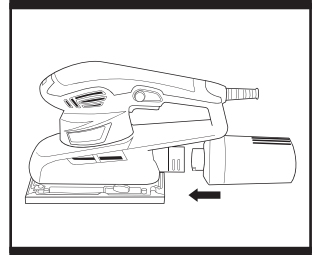

Fig. 6

3. Different types of sanding paper will allow the sander to meet various needs. Different grades of sanding paper are available, the higher grade number, the finer the grit. For rough work start with a low grade of grit (i.e. 60 grade) and change to a higher, finer grade (i.e. 100 or 120) for finishing. If you use a fine grade for rough surfaces it will soon clog and need frequent changing.
4. At all times, let the sander do the work-do not force it or apply excessive pressure to the sanding paper or it could wrinkle or tear. Preferably, use a light circular motion.
5. If the surface shows excessive marking from the abrasive motion, you may be using a grit which is too coarse or applying too much pressure.

## **MAINTENANCE**

**Remove the plug from the socket before carrying out any adjustment, servicing or maintenance.**

Your power tool requires no additional lubrication or maintenance. There are no user serviceable parts in your power tool. Never use water or chemical cleaners to clean your power tool. Wipe clean with a dry cloth. Always store your power tool in a dry place. Keep the motor ventilation slots clean. Keep all working controls free of dust. Occasionally you may see sparks through the ventilation slots. This is normal.

If the supply cord is damaged, it must be replaced by the manufacturer, its service agent or similarly qualified persons in order to avoid a hazard.

## **TROUBLESHOOTING**

1. If your sander will not operate, check the power at the mains plug and the fuse of the plug.
2. If the sander does not abrade surface, checking the sanding paper. If the sanding paper have been worn, replace a new paper and try again. The paper must be kept in a dry place, if it is allowed to become damp, the abrasive particles will lose their adhesion to the backing paper and will not abrade.
3. If the sander dose not move smoothly, The sanding paper may be loose, damaged or wrinkled. Replace and try again.
4. If a fault can not be rectified return the sander to an authorised dealer for repair.

## **ENVIRONMENTAL PROTECTION**



Waste electrical products should not be disposed of with household waste. Please recycle where facilities exist. Check with your Local Authority or retailer for recycling advice. For further information visit [www.recyclemore.co.uk](http://www.recyclemore.co.uk)

## UK PLUG REPLACEMENT

The fuse in the main plug of your power tool should always be replaced with one of identical rating. Check the voltage given on your power tool matches the supply voltage.

The power tool is supplied with a fitted plug, however if you should need to fit a new plug follows the instruction below.

### IMPORTANT

The wire in the mains lead are coloured in accordance with the following code:

**Blue ---Neutral**

**Brown ---Live**

The wire that is coloured **blue** must be connected to the terminal that is marked with the letter **N**. The wire that is coloured **brown** must be connected to the terminal that is marked with the letter **L**.

A 13 AMP (BS1363 or BS1363/A) plug must be used and a 5 AMP fuse must be fitted.

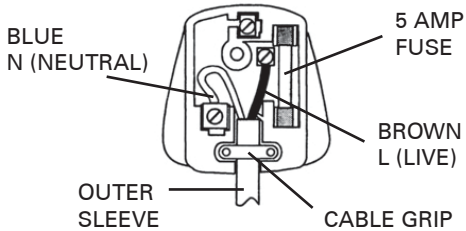

# TITAN®

## Declaration of Conformity

We, Importer  
**Titan Power Tools (UK) Ltd**  
**Trade house, Mead Avenue, BA22 8RT**

Declare that the product:  
**Designation: FINISH SANDER 220W**  
**Model: TTB288SDR**

Complies with the following Directives:  
**2004/108/EC** Electromagnetic Compatibility Directive,  
**2006/42/EC** Machinery Directive  
**2006/95/EC** Low Voltage Directive,  
**2002/95/EC** Restrictions of the Use of Certain Hazardous Substances in Electrical and Electronic Equipment  
**2002/96/EC and 2003/108/EC** Waste Electrical and Electronic Equipment (WEEE),

Standards and technical specifications referred to:

**EN 60745-1: 2009**  
**EN 60745-2-4: 2009**  
**EN 55014-1: 2006+A1: 2009**  
**EN 55014-2:1997+A1: 2001+A2: 2008**  
**EN 61000-3-2: 2006**  
**EN 61000-3-3: 2008**

### Authorised signatory and technical file holder

Date: 07/07/2010

Signature: \_\_\_\_\_

Name / title: Peter Harries / Quality Manager

Titan Power Tools (UK)Ltd. Trade House , Mead Avenue ,BA22 8RT



# FINISH SANDER 220W

# TTB288SDR